



# Assembly and operating manual

## KTG

### 2-finger parallel gripper

Original operating manual

Hand in hand for tomorrow

## Imprint

### Copyright:

This manual is protected by copyright. The author is SCHUNK SE & Co. KG.  
All rights reserved.

### Technical changes:

We reserve the right to make alterations for the purpose of technical improvement.

**Document number:** 389181

**Version:** 08.00 | 04/12/2025 | en

Dear Customer,

Thank you for trusting our products and our family-owned company, the leading technology supplier of robots and production machines.

Our team is always available to answer any questions on this product and other solutions. Ask us questions and challenge us. We will find a solution!

Best regards,

Your SCHUNK team

Customer Management

Tel. +49-7133-103-2503

Fax +49-7133-103-2189

cmg@de.schunk.com



**Please read the operating manual in full and keep it close to the product.**

## Table of Contents

<b>1 General</b> .....	<b>5</b>
1.1 About this manual.....	5
1.1.1 Presentation of Warning Labels .....	5
1.1.2 Applicable documents .....	6
1.1.3 Sizes.....	6
1.2 Warranty .....	6
1.3 Scope of delivery.....	6
1.4 Accessories .....	6
1.4.1 Accessories pack.....	7
1.4.2 Seal kit .....	7
1.4.3 Sensors .....	7
<b>2 Basic safety notes</b> .....	<b>8</b>
2.1 Intended use.....	8
2.2 Constructional changes.....	8
2.3 Spare parts .....	8
2.4 Gripper fingers .....	8
2.5 Ambient conditions and operating conditions .....	9
2.6 Personnel qualification .....	9
2.7 Personal protective equipment .....	10
2.8 Notes on safe operation.....	11
2.9 Transport.....	11
2.10 Malfunctions.....	11
2.11 Disposal .....	12
2.12 Fundamental dangers .....	12
2.12.1 Protection during handling and assembly .....	12
2.12.2 Protection during commissioning and operation .....	13
2.12.3 Protection against dangerous movements .....	13
2.12.4 Protection against electric shock.....	14
2.13 Notes on particular risks .....	14
<b>3 Technical data</b> .....	<b>16</b>
<b>4 Assembly</b> .....	<b>17</b>
4.1 Mounting and centering the gripper.....	17
4.2 Air connection .....	17
4.3 Opening stroke limitation .....	18
4.4 Top jaws .....	20
4.5 Mounting the sensor.....	21
4.5.1 Inductive proximity switch IN 80 .....	21

<b>5 Troubleshooting</b> .....	<b>24</b>
5.1 Product does not move.....	24
5.2 Product is not executing the complete stroke .....	24
5.3 Product opens or closes abruptly .....	24
5.4 Gripping force is dropping.....	24
<b>6 Maintenance</b> .....	<b>25</b>
<b>7 Translation of the original declaration of incorporation</b> .....	<b>26</b>
<b>8 UKCA declaration of incorporation</b> .....	<b>27</b>
<b>9 Annex to declaration of Incorporation</b> .....	<b>28</b>

# 1 General

## 1.1 About this manual

This manual contains important information for a safe and appropriate use of the product.

This manual is an integral part of the product and must be kept accessible for the personnel at all times.

Before starting work, the personnel must have read and understood this operating manual. Prerequisite for safe working is the observance of all safety instructions in this manual.

In addition to these instructions, the documents listed under ▶ 1.1.2 [ 6 ] are applicable.

**NOTE:** The illustrations in this manual are intended to provide a basic understanding and may deviate from the actual version.

### 1.1.1 Presentation of Warning Labels

To make risks clear, the following signal words and symbols are used for safety notes.



#### **⚠ DANGER**

**Dangers for persons!**

Non-observance will inevitably cause irreversible injury or death.



#### **⚠ WARNING**

**Dangers for persons!**

Non-observance can lead to irreversible injury and even death.



#### **⚠ CAUTION**

**Dangers for persons!**

Non-observance can cause minor injuries.

#### **NOTICE**

**Material damage!**

Information about avoiding material damage.

### 1.1.2 Applicable documents

- General terms of business \*
- Catalog data sheet of the purchased product \*

The documents labeled with an asterisk (\*) can be downloaded from [schunk.com/downloads](https://schunk.com/downloads).

### 1.1.3 Sizes

This operating manual applies to the following sizes:

- KTG 50

## 1.2 Warranty

If the product is used as intended, the warranty is valid for 24 months from the ex-works delivery date under the following conditions:

- Observe the specified maintenance and lubrication intervals
- Observe the ambient conditions and operating conditions

Parts touching the workpiece and wear parts are not included in the warranty.

## 1.3 Scope of delivery

The scope of delivery includes

- 2-finger parallel gripper KTG in the version ordered
- Assembly and Operating Manual
- Accessory pack

## 1.4 Accessories

A wide range of accessories are available for this product

For information regarding which accessory articles can be used with the corresponding product variants, see catalog data sheet.

### 1.4.1 Accessories pack

Content of the accessory pack:

- Centering bushing
- Set-screws
- Cylindrical pin
- Screw
- O-rings
- Locking screw

Accessory pack for	ID number
KTG 50	5509421

*Tab.: ID.-No. of the accessory pack*

### 1.4.2 Seal kit

Content of the sealing kit:

- Cylinder seals
- O-rings

Seal kit for	ID number
KTG 50	5518749

*Tab.: ID.-No. of the seal kit*

### 1.4.3 Sensors

Designation	Type
Inductive proximity switches	IN

- Exact type designation of the compatible sensors see catalog.
- Information on handling sensors is available at [schunk.com](http://schunk.com) or from SCHUNK contact persons.
- For mounting the sensors, mounting kits are partly necessary.

## 2 Basic safety notes

### 2.1 Intended use

The product is designed exclusively for gripping and temporarily holding workpieces or objects.

- The product may only be used within the scope of its technical data, ▶ 3 [16].
- The product is intended for installation in a machine/ automated system. The applicable guidelines for the machine/ automated system must be observed and complied with.
- The product is intended for industrial and industry-oriented use. Its use outside enclosed spaces is only permitted if suitable protective measures are taken against outdoor exposure. The product is not suitable for use in salty air.
- The product can be used within the permissible load limits and technical data for holding workpieces during simple machining operations, but is not a clamping device according to EN 1550:1997+A1:2008.
- Appropriate use of the product includes compliance with all instructions in this manual.
- Any utilization that exceeds or differs from the appropriate use is regarded as misuse.

### 2.2 Constructional changes

#### Implementation of structural changes

Modifications, changes or reworking, e.g. additional threads, holes, or safety devices, can damage the product or impair its functionality or safety.

- Structural changes should only be made with the written approval of SCHUNK.

### 2.3 Spare parts

#### Use of unauthorized spare parts

Using unauthorized spare parts can endanger personnel and damage the product or cause it to malfunction.

- Use only original spare parts or spares authorized by SCHUNK.

### 2.4 Gripper fingers

#### Requirements for the gripper fingers

Accumulated energy can make the product unsafe and risk the danger of serious injuries and considerable material damage.

- Only change gripper fingers if no residual energy can be released.
- Make sure that the product and the top jaws are a sufficient size for the application.

## 2.5 Ambient conditions and operating conditions

### Required ambient conditions and operating conditions

Incorrect ambient and operating conditions can make the product unsafe, leading to the risk of serious injuries, considerable material damage and/or a significant reduction to the product's life span.

- Make sure that the product is used only in the context of its defined application parameters, ▶ 3 [ 16].
- Make sure that the product and the top jaws are a sufficient size for the application.
- Make sure that the environment is free from splash water and vapors as well as from abrasion or processing dust. Exceptions are products that are designed especially for contaminated environments.

## 2.6 Personnel qualification

### Inadequate qualifications of the personnel

If the personnel working with the product is not sufficiently qualified, the result may be serious injuries and significant property damage.

- All work may only be performed by qualified personnel.
- Before working with the product, the personnel must have read and understood the complete assembly and operating manual.
- Observe the national safety regulations and rules and general safety instructions.

The following personal qualifications are necessary for the various activities related to the product:

#### Trained electrician

Due to their technical training, knowledge and experience, trained electricians are able to work on electrical systems, recognize and avoid possible dangers and know the relevant standards and regulations.

#### Qualified personnel

Due to its technical training, knowledge and experience, qualified personnel is able to perform the delegated tasks, recognize and avoid possible dangers and knows the relevant standards and regulations.

<b>Instructed person</b>	Instructed persons were instructed by the operator about the delegated tasks and possible dangers due to improper behaviour.
<b>Service personnel of the manufacturer</b>	Due to its technical training, knowledge and experience, service personnel of the manufacturer is able to perform the delegated tasks and to recognize and avoid possible dangers.

## 2.7 Personal protective equipment

### Use of personal protective equipment

Personal protective equipment serves to protect staff against danger which may interfere with their health or safety at work.

- When working on and with the product, observe the occupational health and safety regulations and wear the required personal protective equipment.
- Observe the valid safety and accident prevention regulations.
- Wear protective gloves to guard against sharp edges and corners or rough surfaces.
- Wear heat-resistant protective gloves when handling hot surfaces.
- Wear protective gloves and safety goggles when handling hazardous substances.
- Wear close-fitting protective clothing and also wear long hair in a hairnet when dealing with moving components.

## 2.8 Notes on safe operation

### Incorrect handling of the personnel

Incorrect handling and assembly may impair the product's safety and cause serious injuries and considerable material damage.

- Avoid any manner of working that may interfere with the function and operational safety of the product.
- Use the product as intended.
- Observe the safety notes and assembly instructions.
- Do not expose the product to any corrosive media. This does not apply to products that are designed for special environments.
- Eliminate any malfunction immediately.
- Observe the care and maintenance instructions.
- Observe the current safety, accident prevention and environmental protection regulations regarding the product's application field.

## 2.9 Transport

### Handling during transport

Incorrect handling during transport may impair the product's safety and cause serious injuries and considerable material damage.

- When handling heavy weights, use lifting equipment to lift the product and transport it by appropriate means.
- Secure the product against falling during transportation and handling.
- Stand clear of suspended loads.

## 2.10 Malfunctions

### Behavior in case of malfunctions

- Immediately remove the product from operation and report the malfunction to the responsible departments/persons.
- Order appropriately trained personnel to rectify the malfunction.
- Do not recommission the product until the malfunction has been rectified.
- Test the product after a malfunction to establish whether it still functions properly and no increased risks have arisen.

## 2.11 Disposal

### Handling of disposal

The incorrect handling of disposal may impair the product's safety and cause serious injuries as well as considerable material and environmental harm.

- Follow local regulations on dispatching product components for recycling or proper disposal.

## 2.12 Fundamental dangers

### General

- Observe safety distances.
- Never deactivate safety devices.
- Before commissioning the product, take appropriate protective measures to secure the danger zone.
- Disconnect power sources before installation, modification, maintenance, or calibration. Ensure that no residual energy remains in the system.
- If the energy supply is connected, do not move any parts by hand.
- Do not reach into the open mechanism or movement area of the product during operation.

### 2.12.1 Protection during handling and assembly

#### Incorrect handling and assembly

Incorrect handling and assembly may impair the product's safety and cause serious injuries and considerable material damage.

- Have all work carried out by appropriately qualified personnel.
- For all work, secure the product against accidental operation.
- Observe the relevant accident prevention rules.
- Use suitable assembly and transport equipment and take precautions to prevent jamming and crushing.

#### Incorrect lifting of loads

Falling loads may cause serious injuries and even death.

- Stand clear of suspended loads and do not step into their swiveling range.
- Never move loads without supervision.
- Do not leave suspended loads unattended.

## 2.12.2 Protection during commissioning and operation

### Falling or violently ejected components

Falling and violently ejected components can cause serious injuries and even death.

- Take appropriate protective measures to secure the danger zone.
- Never step into the danger zone during operation.

## 2.12.3 Protection against dangerous movements

### Unexpected movements

Residual energy in the system may cause serious injuries while working with the product.

- Switch off the energy supply, ensure that no residual energy remains and secure against inadvertent reactivation.
- Never rely solely on the response of the monitoring function to avert danger. Until the installed monitors become effective, it must be assumed that the drive movement is faulty, with its action being dependent on the control unit and the current operating condition of the drive. Perform maintenance work, modifications, and attachments outside the danger zone defined by the movement range.
- To avoid accidents and/or material damage, human access to the movement range of the machine must be restricted. Limit/prevent accidental access for people in this area due through technical safety measures. The protective cover and protective fence must be rigid enough to withstand the maximum possible movement energy. EMERGENCY STOP switches must be easily and quickly accessible. Before starting up the machine or automated system, check that the EMERGENCY STOP system is working. Prevent operation of the machine if this protective equipment does not function correctly.

## 2.12.4 Protection against electric shock

### Possible electrostatic energy

Components or assembly groups may become electrostatically charged. When the electrostatic charge is touched, the discharge may trigger a shock reaction leading to injuries.

- The operator must ensure that all components and assembly groups are included in the local potential equalisation in accordance with the applicable regulations.
- While paying attention to the actual conditions of the working environment, the potential equalisation must be implemented by a specialist electrician according to the applicable regulations.
- The effectiveness of the potential equalisation must be verified by executing regular safety measurements.

## 2.13 Notes on particular risks



### **⚠ WARNING**

#### **Risk of injury from crushing and impacts!**

Serious injury could occur during movement of the base jaw, due to breakage or loosening of the gripper fingers or if the workpiece is lost.

- Wear suitable protective equipment.
- Do not reach into the open mechanism or the movement area of the product.



### **⚠ WARNING**

#### **Risk of injury from objects falling and being ejected!**

Falling and ejected objects during operation can lead to serious injury or death.

- Take appropriate protective measures to secure the danger zone.



## **⚠ WARNING**

### **Risk of injury due to unexpected movements!**

If the power supply is switched on or residual energy remains in the system, components can move unexpectedly and cause serious injuries.

- Before starting any work on the product: Switch off the power supply and secure against restarting.
  - Make sure, that no residual energy remains in the system.
-

### 3 Technical data

Stroke per jaw [mm]	4.5
Diameter of the center bore [mm]	5
Max. permissible finger length [mm]	50
Max. permitted weight per finger [kg]	0.04
Closing force [N]/Opening force [N]	13 / 13
Closing time [s]/Opening time [s]	0.05 / 0.05
Weight [kg]	0.08
Recommended workpiece weight [kg]	0.07
Pressure medium	Compressed air, compressed air quality according to ISO 8573-1:2010 [7:4:4]
Air consumption per cylinder volume [cm <sup>3</sup> ]	0.23
Min. pressure [bar]	1
Max. pressure [bar]	7
Nominal working pressure [bar]	6
IP rating	20
Repeatability [mm]	0.02
Min. ambient temperature [°C]	5
Max. ambient temperature [°C]	90
Noise emission [dB(A)]	≤70

## 4 Assembly

### 4.1 Mounting and centering the gripper

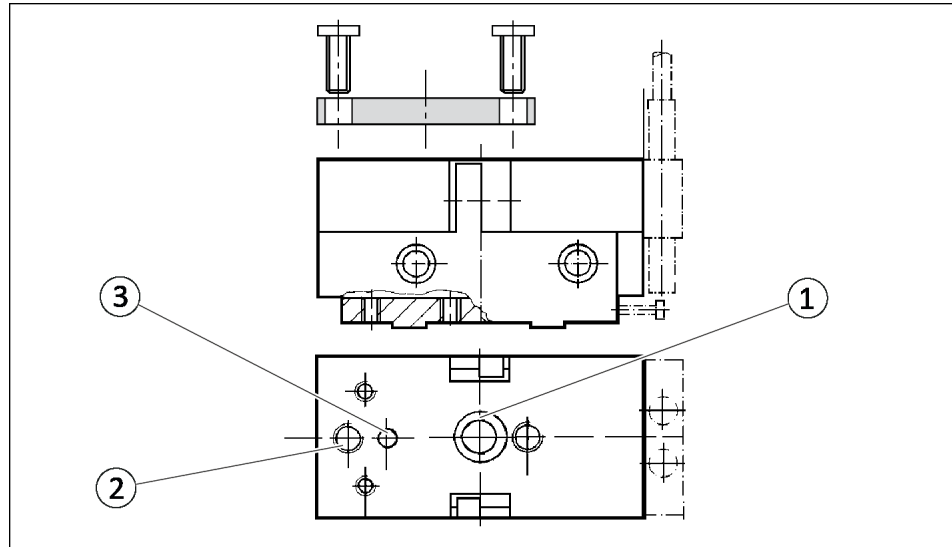

- |   |  |
|---|--|
| 1 | Bore hole for centering sleeve ( $\varnothing 8m6$ ) * |
| 2 | 2x threaded hole for gripper mounting (M4/5 deep)      |
| 3 | Bore hole for cylindrical pin ( $\varnothing 3m6$ ) *  |

\* Contained in accessory pack.

### 4.2 Air connection

#### NOTE

- Observe the requirements for the compressed air supply, ▶ 3 [16].
- In case of compressed air loss (cutting off the energy line), the components lose their dynamic effects and do not remain in a secure position. However, the use of a SDV-P pressure maintenance valve is recommended in this case in order to maintain the dynamic effect for some time. Product variants are also offered with mechanical gripping force via springs, which also ensure a minimum clamping force in the event of a pressure drop.

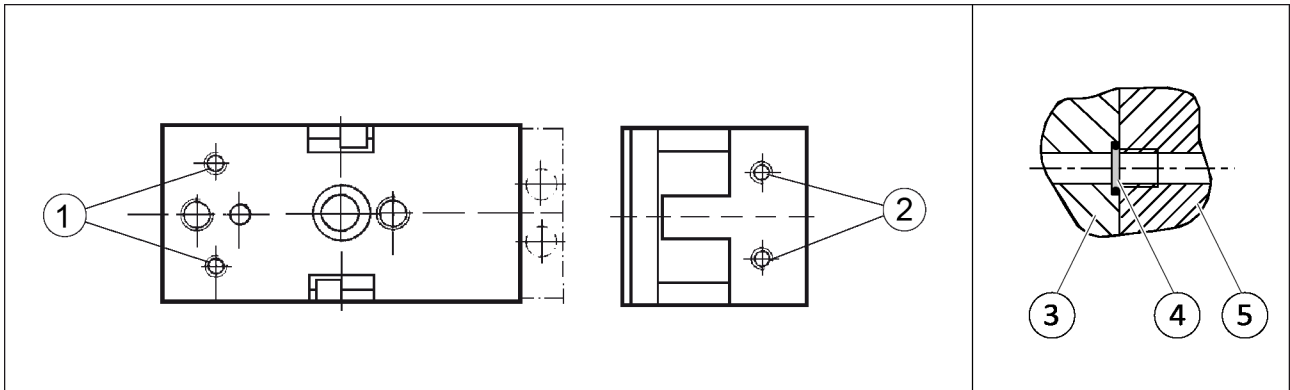

- 1 Hose-free direct connection at the base  
(a = open, b = close)

---

- 2 Main connections (Hose connection)  
(A = open, B = close)

---

Hose-free direct connection

- 3 Attachment

---

- 4 O ring

---

- 5 Product

---

- Only open the air connections required.
- Seal those main air connections that are not needed using the locking screws from the accessory kit.
- Seal any air connections not required using threadlocker (Loctite 582 or similar).
- For hose-free direct connections, use the O-rings from the accessory kit.

### 4.3 Opening stroke limitation



#### **⚠ WARNING**

#### **Danger of crushing when moving the gripper fingers!**

Do not reach between the gripper fingers when the product is pressurized with compressed air.

The opening stroke of 4 mm per jaw can be steplessly limited e.g. in order to enable assembly under cramped conditions. The stroke is limited using threaded pins (included in accessory kit), which are stuck into the main air connections. For this reason a gripper with stroke limitation can only be supplied with compressed air via the hose-free direct connection.

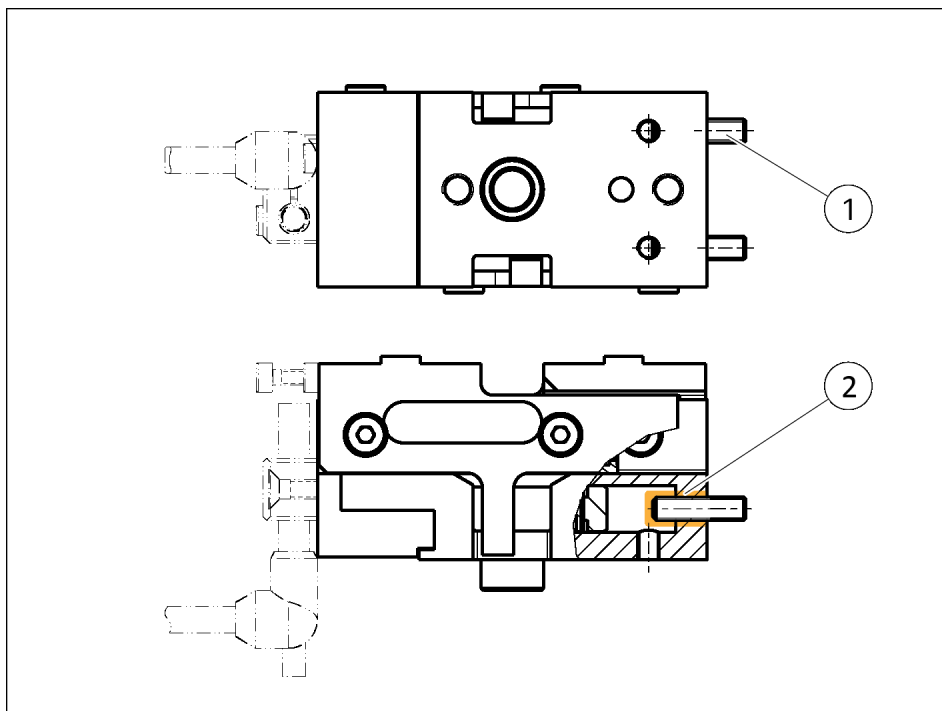

*Installing the stroke limitation*

1. If necessary remove the side locking screws or hose connections from the housing (version depends on design).
2. Clean and degrease both threaded holes (2) and the threaded pins M3x12 (1, included in accessory kit).
3. Coat the threaded pins (1) with threadlocker (Loctite 582 or similar) and immediately screw into the threaded holes (2) until the desired stroke is set.
4. Await the prescribed curing time.

**WARNING! For safe operation of the product, perform a leak tightness test before commissioning.**

### 4.4 Top jaws

The base jaws are each equipped with four M3 threads and a bar. Use at least two threads to fasten your top jaws.

**NOTICE**

**Damage to the top jaw blanks due to exceedance of the max. depth of engagement!**

Observe a max. depth of engagement of 3 mm!

Use the bar to mount the top jaws.

Type	ID number
	<b>For one set = 2 x</b>
RB 50	0300280

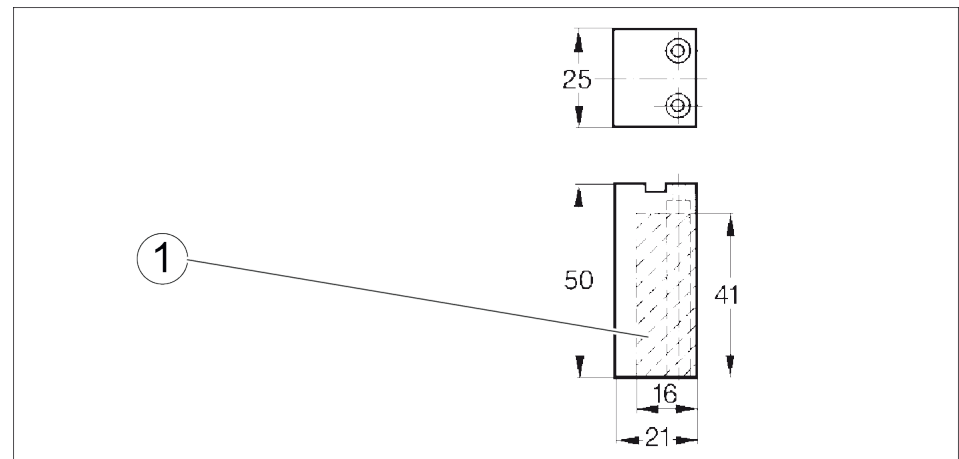

Jaw blanks

2	Machining area for specific adjustment
---	--

## 4.5 Mounting the sensor

### NOTE

Observe the assembly and operating manual of the sensor for mounting and connecting.

The product is prepared for the use of sensors.

- For the exact type designations of suitable sensors, please see catalog datasheet and Link Übersicht Sensoren.
- For technical data for the suitable sensors, see assembly and operating manual and catalog datasheet.
  - The assembly and operating manual and catalog datasheet are included in the scope of delivery for the sensors and are available at [schunk.com](http://schunk.com).
- Information on handling sensors is available at [schunk.com](http://schunk.com) or from SCHUNK contact persons.

### 4.5.1 Inductive proximity switch IN 80

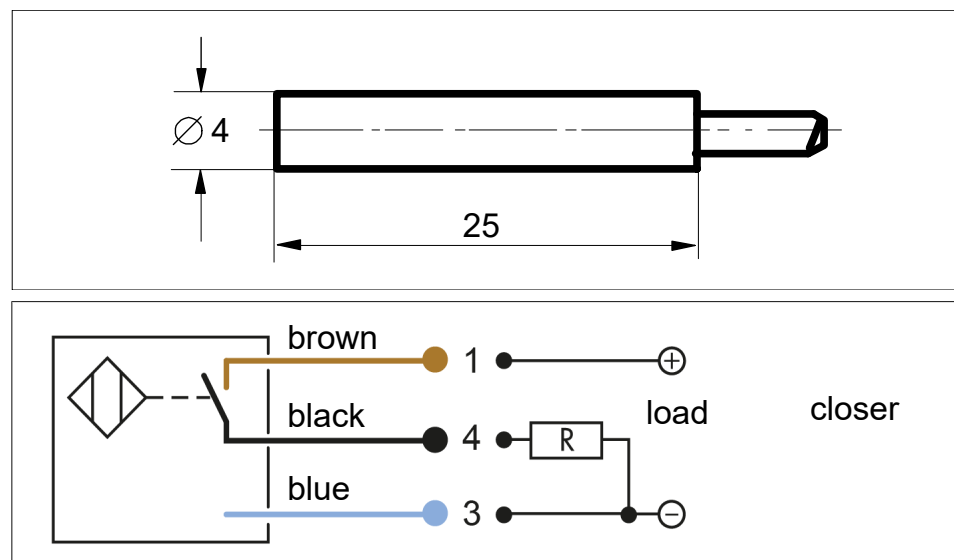

Types that can be ordered (☞ catalog):

The inductive proximity switches used are equipped with reverse polarity protection and are short-circuit-proof.

Make sure that you handle the proximity switches properly:

- Do not pull on the cable.
- Do not allow the sensor to dangle from the cable.
- Do not overtighten the mounting screw or mounting clip.
- Please adhere to a permitted bend radius of the cable (☞ catalog).

- Avoid contact of the proximity switches with hard objects and with chemicals, in particular nitric acid, chromic acid and sulphuric acid.

The inductive proximity switches are electronic components, which can react sensitively to high-frequency interference or electromagnetic fields.

- Check to make sure that the cable is fastened and installed correctly. Provide for sufficient clearance to sources of high-frequency interference and their supply cables.
- Parallel switching of several sensor outputs of the same type (npn, pnp) is permissible, but does not increase the permissible load current.
- Note that the leakage current of the individual sensors (approx. 2 mA) is cumulative.

### Assembly and adjustment

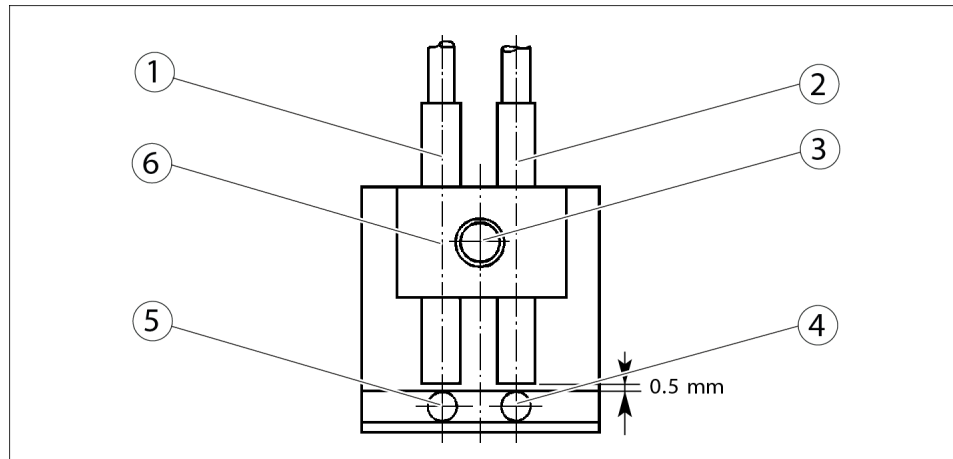

Proximity switch

1	"OPEN" proximity switch	4	Long switching lug
2	"CLOSED" proximity switch	5	Short switching lug
3	Clamping screw	6	Bracket for proximity switch

1. Loosen the attachment screw (3) on the bracket.
2. Push the proximity switch (1/2) through the bore holes in the bracket (6).  
Observe a distance of 0.5 mm to the switching lug.
3. Secure the proximity switch by tightening the attachment screw (3) (max. tightening torque of 1 Nm).
4. If necessary, adjust the switching lugs (4/5) so that the head of the switching lug is above the center of the respective proximity switch in the desired position of the base jaw.

5. To monitor intermediate positions, the long switching lug (5) may have to be replaced with the M2 x 8 screw from the accessory pack.
6. After correct adjustment, secure both switching lugs (4/5) with a suitable adhesive.

## 5 Troubleshooting

### 5.1 Product does not move

Possible cause	Corrective action
Base jaws jam in housing, e.g. mounting surface is not sufficiently even.	Check the evenness of the mounting surface. ▶ 4.1 [📄 17]
Pressure drops below minimum.	Check air supply. ▶ 3 [📄 16]
Compressed air lines switched.	Check compressed air lines. ▶ 4.2 [📄 17]
Proximity switch defective or set incorrect.	Readjust or change sensor.
Unused air connections open.	Close unused air connections.
Flow control valve closed.	Open the flow control valve.
Component part defective.	Replace component or send it to SCHUNK for repair.

### 5.2 Product is not executing the complete stroke

Possible cause	Corrective action
Pressure drops below minimum.	Check air supply. ▶ 4.2 [📄 17]
Mounting surface is not sufficiently flat.	Check the evenness of the mounting surface. ▶ 4.1 [📄 17]
Component part defective.	Send the product to SCHUNK with a repair order.

### 5.3 Product opens or closes abruptly

Possible cause	Corrective action
Compressed air lines blocked.	Check compressed air lines of damage.
Mounting surface is not sufficiently flat.	Check the evenness of the mounting surface.
One-way flow control valve is missing or adjustet incorrectly.	Install and adjust one-way flow control valve.
Loading too large.	Check permissible weight and length of the gripper fingers.

### 5.4 Gripping force is dropping

Possible cause	Corrective action
Compressed air can escape.	Check seals, if necessary, disassemble the product and replace seals.
Pressure drops below minimum.	Check air supply. ▶ 4.2 [📄 17]

## 6 Maintenance

The product is maintenance-free.

Observe the following notes to maintain the function of the gripper:

- Avoid excessive contamination.
- Oil or grease bare external steel parts.

Always use dried air.

- Unless otherwise specified, secure all screws and nuts with Loctite no. 243 and tighten with the appropriate tightening torque.

## 7 Translation of the original declaration of incorporation

in terms of the Directive 2006/42/EG, Annex II, Part 1 Section B.

Manufacturer/  
Distributor                      SCHUNK SE & Co. KG  
Spanntechnik | Greiftechnik | Automatisierungstechnik  
Bahnhofstr. 106 – 134  
D-74348 Lauffen/Neckar

We hereby declare that the partly completed machine described below

Product designation:        2-finger parallel gripper / KTG /pneumatic  
ID number                      300275

meets the following basic occupational health and safety of the Machinery Directive 2006/42/EC:

No. 1.1.1, No. 1.1.2, No. 1.1.3, No. 1.1.5, No. 1.3.2, No. 1.5.3, No. 1.5.4, No. 1.5.6, No. 1.5.8, No. 1.5.10, No. 1.5.11, No. 1.5.13

The partly completed machinery may not be put into operation until it has been confirmed that the machine into which the partly completed machinery is to be installed complies with the provisions of the Machinery Directive (2006/42/EC). The declaration shall be rendered invalid if modifications are made to the product.

Applied harmonized standards, especially:

EN ISO 12100:2010                Safety of machinery – General principles for design –  
Risk assessment and risk reduction

The special technical documentation according to Annex VII, Part B, belonging to the partly completed machine, has been created.

Person authorized to compile the technical documentation:  
Stefanie Walter, Address: see manufacturer's address

*Signature: see original declaration*

Lauffen/Neckar, January 2023

p.p. Ralf Winkler; Head of Technology & Engineering,  
Mechanics Gripping Systems

## 8 UKCA declaration of incorporation

in accordance with the Supply of Machinery (Safety) Regulations 2008.

Manufacturer/	SCHUNK Intec Limited
Distributor	Clamping and gripping technology 3 Drakes Mews, Crownhill MK8 0ER Milton Keynes

We hereby declare that on the date of the declaration the following partly completed machine complied with all basic safety and health regulations found in the "Supply of Machinery (Safety) Regulations 2008".

The declaration shall be rendered invalid if modifications are made to the product.

Product designation:	2-finger parallel gripper / KTG / pneumatic
ID number	300275

The partly completed machine may not be put into operation until it has been confirmed that the machine into which the partly completed machine is to be installed complies with the provisions of the "Supply of Machinery (Safety) Regulations 2008".

Applied harmonized standards, especially:

EN ISO 12100:2010	Safety of machinery – General principles for design – Risk assessment and risk reduction
-------------------	---

The special technical documentation according to Annex VII, Part B, belonging to the partly completed machine, has been created.

Person authorized to compile the technical documentation:  
Marcel Machado, address: refer to manufacturer's address



Lauffen/Neckar, January 2023

p.p. Ralf Winkler; Head of Technology & Engineering,  
Mechanics Gripping Systems

## 9 Annex to declaration of Incorporation

in accordance with 2006/42/EC, Appendix II, no. 1 B

as well as

in accordance with the Supply of Machinery (Safety) Regulations 2008.

1. Description of the basic safety and health protection requirements, as per 2006/42/EC, Annex I and per the Supply of Machinery (Safety) Regulations 2008, that apply to and are fulfilled for the scope of the incomplete machine:

Product designation 2-finger parallel gripper

Type designation KTG

ID number 300275

### Legend:

To be provided by the System Integrator for the overall machine



Fulfilled for the scope of the partly completed machine



Not relevant



### 1.1 Essential Requirements

1.1.1 Definitions



1.1.2 Principles of safety integration



1.1.3 Materials and products



1.1.4 Lighting



1.1.5 Design of machinery to facilitate its handling



1.1.6 Ergonomics



1.1.7 Operating positions



1.1.8 Seating



### 1.2 Control Systems

1.2.1 Safety and reliability of control systems



1.2.2 Control devices



1.2.3 Starting



1.2.4 Stopping



1.2.4.1 Normal stop



1.2.4.2 Operational stop



1.2.4.3 Emergency stop





























1.2.4.4 Assembly of machinery





1.2.5 Selection of control or operating modes



<b>1.2</b>	<b>Control Systems</b>	
1.2.6	Failure of the power supply	
<b>1.3</b>	<b>Protection against mechanical hazards</b>	
1.3.1	Risk of loss of stability	
1.3.2	Risk of break-up during operation	
1.3.3	Risks due to falling or ejected objects	
1.3.4	Risks due to surfaces, edges or angles	
1.3.5	Risks related to combined machinery	
1.3.6	Risks related to variations in operating conditions	
1.3.7	Risks related to moving parts	
1.3.8	Choice of protection against risks arising from moving parts	
1.3.8.1	Moving transmission parts	
1.3.8.2	Moving parts involved in the process	
1.3.9	Risks of uncontrolled movements	
<b>1.4</b>	<b>Required characteristics of guards and protective devices</b>	
1.4.1	General requirements	
1.4.2	Special requirements for guards	
1.4.2.1	Fixed guards	
1.4.2.2	Interlocking movable guards	
1.4.2.3	Adjustable guards restricting access	
1.4.3	Special requirements for protective devices	
<b>1.5</b>	<b>Risks due to other hazards</b>	
1.5.1	Electricity supply	
1.5.2	Static electricity	
1.5.3	Energy supply other than electricity	
1.5.4	Errors of fitting	
1.5.5	Extreme temperatures	
1.5.6	Fire	
1.5.7	Explosion	
1.5.8	Noise	
1.5.9	Vibrations	
1.5.10	Radiation	
1.5.11	External radiation	

<b>1.5</b>	<b>Risks due to other hazards</b>	
1.5.12	Laser radiation	
1.5.13	Emissions of hazardous materials and substances	
1.5.14	Risk of being trapped in a machine	
1.5.15	Risk of slipping, tripping or falling	
1.5.16	Lightning	
<b>1.6</b>	<b>Maintenance</b>	
1.6.1	Machinery maintenance	
1.6.2	Access to operating positions and servicing points	
1.6.3	Isolation of energy sources	
1.6.4	Operator intervention	
1.6.5	Cleaning of internal parts	
<b>1.7</b>	<b>Information</b>	
1.7.1	Information and warnings on the machinery	
1.7.1.1	Information and information devices	
1.7.1.2	Warning devices	
1.7.2	Warning of residual risks	
1.7.3	Marking of machinery	
1.7.4	Instructions	
1.7.4.1	General principles for the drafting of instructions	
1.7.4.2	Contents of the instructions	
1.7.4.3	Sales literature	
<b>The classification from Annex 1 is to be supplemented from here forward.</b>		
2	Supplementary essential health and safety requirements for certain categories of machinery	
2.1	Foodstuffs machinery and machinery for cosmetics or pharmaceutical products	
2.2	Portable hand-held and/or guided machinery	
2.2.1	Portable fixing and other impact machinery	
2.3	Machinery for working wood and material with similar physical characteristics	
3	Supplementary essential health and safety requirements to offset hazards due to the mobility of machinery	
4	Supplementary essential health and safety requirements to offset hazards due to lifting operations	

**The classification from Annex 1 is to be supplemented from here forward.**

5	Supplementary essential health and safety requirements for machinery intended for underground work	
6	Supplementary essential health and safety requirements for machinery presenting particular hazards due to the lifting of persons	



**SCHUNK SE & Co. KG**  
Spanntechnik | Greiftechnik | Automatisierungstechnik

Bahnhofstr. 106 - 134  
D-74348 Lauffen/Neckar  
Tel. +49-7133-103-0  
info@de.schunk.com  
schunk.com

Folgen Sie uns | *Follow us*



Wir drucken nachhaltig | *We print sustainable*