



Assembly and Operating Manual

ORG

0-ring gripper

Translation of the original manual

Hand in hand for tomorrow

Imprint

Copyright:

This manual is protected by copyright. The author is SCHUNK SE & Co. KG.
All rights reserved.

Technical changes:

We reserve the right to make alterations for the purpose of technical improvement.

Document number: 389246

Version: 11.00 | 12/02/2026 | en

Dear Customer,

Thank you for trusting our products and our family-owned company, the leading technology supplier of robots and production machines.

Our team is always available to answer any questions on this product and other solutions. Ask us questions and challenge us. We will find a solution!

Best regards,

Your SCHUNK team

Customer Management

Tel. +49-7133-103-2503

Fax +49-7133-103-2189

cmg@de.schunk.com



Please read the operating manual in full and keep it close to the product.

Table of Contents

1	General	6
1.1	About this manual.....	6
1.1.1	Presentation of Warning Labels	6
1.1.2	Applicable documents	7
1.1.3	Sizes.....	7
1.2	Warranty	7
1.3	Scope of delivery.....	7
1.4	Accessories	7
1.4.1	Seal kit	7
1.4.2	Seals to be mounted	8
2	Basic safety notes	9
2.1	Intended use.....	9
2.2	Constructional changes.....	9
2.3	Spare parts	9
2.4	Gripper fingers	9
2.5	Ambient conditions and operating conditions	10
2.6	Personnel qualification	10
2.7	Personal protective equipment	11
2.8	Notes on safe operation.....	11
2.9	Transport.....	12
2.10	Malfunctions.....	12
2.11	Disposal	12
2.12	Fundamental dangers	12
2.12.1	Protection during handling and assembly	13
2.12.2	Protection during commissioning and operation	13
2.12.3	Protection against dangerous movements	13
2.13	Notes on particular risks	15
3	Technical data	17
4	Assembly and installation.....	18
4.1	Installing and connecting	18
4.2	Connections	19
4.2.1	Mechanical connection.....	19
4.2.2	Pneumatic connection.....	20
4.3	Transfer point seal.....	21

4.4	Installing gripper fingers	21
4.4.1	External assembly inner seal diameter between d1=10 mm and d1=60 mm	22
4.4.2	External assembly inner seal diameter between d1>d1max. and d1=150 mm	24
4.4.3	Internal assembly inner seal diameter between d1=20 mm and d1=approx. 120 mm	26
4.5	Setting the end positions	29
4.6	Mounting the sensor	31
4.6.1	Overview of sensors	31
4.6.2	Assembly drawing mounting kit	32
4.6.3	Mounting inductive proximity switch IN 30	34
4.6.4	Mounting the sensor cables	41
5	Function and handling	42
5.1	Pneumatic circuit diagram	42
5.2	Function diagram external assembly	44
5.3	Details of external assembly procedure, Range of inside seal diameter between d1=10 mm and d1=60 mm	47
5.3.1	External assembly AM_1.1	47
5.3.2	External assembly AM_1.2	48
5.3.3	External assembly AM_1.3	49
5.3.4	External assembly AM_1.4	50
5.3.5	External assembly AM_1.5	51
5.3.6	External assembly AM_1.6	51
5.4	Details of external assembly procedure, Range of inside seal diameter between d1>60 mm and approx. d1=150 mm	52
5.4.1	External assembly AM_2.1	52
5.4.2	External assembly AM_2.2	53
5.4.3	External assembly AM_2.3	54
5.4.4	External assembly AM_2.4	55
5.4.5	External assembly AM_2.5	56
5.4.6	External assembly AM_2.6	57
5.5	Function diagram internal assembly	58
5.6	Details of internal assembly procedure	61
5.6.1	Internal assembly IM_1.1	61
5.6.2	Internal assembly IM_1.2	62
5.6.3	Internal assembly IM_1.3	62
5.6.4	Internal assembly IM_1.4	64
5.6.5	Internal assembly IM_1.5	67
5.6.6	Internal assembly IM_1.6	68
5.6.7	Internal assembly IM_1.7	70
5.6.8	Internal assembly IM_1.8	71

5.6.9 Internal assembly IM_1.9	72
5.6.10 Internal assembly IM_1.10	73
6 Troubleshooting.....	74
6.1 Checking the opening and closing times.....	74
7 Maintenance	75
7.1 Notes.....	75
7.2 Utensils required for maintenance	75
7.3 Maintenance and servicing intervals	75
7.4 Lubricants/Lubrication points (basic lubrication)	76
7.5 Screw tightening torque	76
7.6 Gripper design.....	77
7.7 Disassembling the gripper	78
7.7.1 Disassembling assembly group 1 (Triple jaw unit A)	78
7.7.2 Disassembling assembly group 2 (Triple jaw unit B).....	79
7.7.3 Disassembly of assembly group 3 (Drive unit triple jaw B).....	83
7.8 Servicing the product	83
7.9 Assembly drawing	84
8 Translation of the original declaration of incorporation	85
9 UKCA declaration of incorporation	86
10 Information on the RoHS Directive, REACH Regulation and Substances of Very High Concern (SVHC)	87

1 General

1.1 About this manual

This manual contains important information for a safe and appropriate use of the product.

This manual is an integral part of the product and must be kept accessible for the personnel at all times.

Before starting work, the personnel must have read and understood this operating manual. Prerequisite for safe working is the observance of all safety instructions in this manual.

In addition to these instructions, the documents listed under ▶ 1.1.2 [7] are applicable.

NOTE: The illustrations in this manual are intended to provide a basic understanding and may deviate from the actual version.

1.1.1 Presentation of Warning Labels

To make risks clear, the following signal words and symbols are used for safety notes.



⚠ DANGER

Dangers for persons!

Non-observance will inevitably cause irreversible injury or death.



⚠ WARNING

Dangers for persons!

Non-observance can lead to irreversible injury and even death.



⚠ CAUTION

Dangers for persons!

Non-observance can cause minor injuries.

NOTICE

Material damage!

Information about avoiding material damage.

1.1.2 Applicable documents

- General terms of business *
- Catalog data sheet of the purchased product *
- Assembly and operating manuals of the accessories *

The documents labeled with an asterisk (*) can be downloaded from schunk.com/downloads.

1.1.3 Sizes

This operating manual applies to the following sizes:

- ORG 85

1.2 Warranty

If the product is used as intended, the warranty is valid for 24 months from the ex-works delivery date under the following conditions:

- Observe the specified maintenance and lubrication intervals
- Observe the ambient conditions and operating conditions

Parts touching the workpiece and wear parts are not included in the warranty.

1.3 Scope of delivery

The scope of delivery includes

- O-ring gripper ORG in the version ordered
- Safety information (product-specific instructions available online)
- Accessory pack

1.4 Accessories

A wide range of accessories are available for this product

For information regarding which accessory articles can be used with the corresponding product variants, see catalog data sheet.

1.4.1 Seal kit

Content of the sealing kit:

- O-rings
- Quad ring

Seal kit for	ID number
ORG 85	5516224

contents of the sealing kit, ► [4.6.2 \[32 \]](#).

1.4.2 Seals to be mounted

External assembly

Inner seal diameter between d1=10 mm and d1=60 mm

The necessary top jaws (gripper finger and segment jaws with clamping jaws) must be selected depending on the seals being fitted.

d ₂ [mm]	NBR 70 Shore A		VITON FPM 70		Quantity [Pcs.]	ID number
	d _{1min.} [mm]	d _{1max.} [mm]	d _{1min.} [mm]	d _{1max.} [mm]		
0.5<d2<1.0	10	45	10	45	6	0304113
1.0<d2<2.0	10	55	10	45	6	0304114
2.0<d2<3.0	10	60	14	60	6	0304115
3.0<d2<4.0	15	60	24	60	6	0304116

The values given in this table are guide values and refer to seals which are mounted at a distance P from the housing! Further seals on request!

Range of inside seal diameter d1>d1max. to d1= approx. 150 mm

Mountable seals as well as segment jaws with clamping jaws upon request!

Internal assembly:

Range of inside seal diameter: d1=20 mm to d1= approx. 120 mm

Mountable seals as well as segments jaws with clamping jaws and gripper fingers Internal assembly on request!

Further information can be found in the catalog data sheet in the appendix.

2 Basic safety notes

2.1 Intended use

The product is designed for gripping, time-limited safe holding, and releasing workpieces preferably for sealing rings (O-ring/quad ring).

- The product may only be used within the scope of its technical data, ▶ 3 [17].
- The product is intended for installation in a machine/automated system. The applicable guidelines for the machine/automated system must be observed and complied with.
- The product is intended for industrial and industry-oriented use. Its use outside enclosed spaces is only permitted if suitable protective measures are taken against outdoor exposure. The product is not suitable for use in salty air.
- The product can be used within the permissible load limits and technical data for holding workpieces during simple machining operations, but is not a clamping device according to EN 1550:1997+A1:2008.
- Appropriate use of the product includes compliance with all instructions in this manual.
- Any utilization that exceeds or differs from the appropriate use is regarded as misuse.

2.2 Constructional changes

Implementation of structural changes

Modifications, changes or reworking, e.g. additional threads, holes, or safety devices, can damage the product or impair its functionality or safety.

- Structural changes should only be made with the written approval of SCHUNK.

2.3 Spare parts

Use of unauthorized spare parts

Using unauthorized spare parts can endanger personnel and damage the product or cause it to malfunction.

- Use only original spare parts or spares authorized by SCHUNK.

2.4 Gripper fingers

Requirements for the gripper fingers

Accumulated energy can make the product unsafe and risk the danger of serious injuries and considerable material damage.

- Only change gripper fingers if no residual energy can be released.
- Make sure that the product and the top jaws are a sufficient size for the application.

2.5 Ambient conditions and operating conditions

Required ambient conditions and operating conditions

Incorrect ambient and operating conditions can make the product unsafe, leading to the risk of serious injuries, considerable material damage and/or a significant reduction to the product's life span.

- Make sure that the product is used only in the context of its defined application parameters, ▶ 3 [17].

2.6 Personnel qualification

Inadequate qualifications of the personnel

If the personnel working with the product is not sufficiently qualified, the result may be serious injuries and significant property damage.

- All work may only be performed by qualified personnel.
- Before working with the product, the personnel must have read and understood the complete assembly and operating manual.
- Observe the national safety regulations and rules and general safety instructions.

The following personal qualifications are necessary for the various activities related to the product:

Trained electrician

Due to their technical training, knowledge and experience, trained electricians are able to work on electrical systems, recognize and avoid possible dangers and know the relevant standards and regulations.

Qualified personnel

Due to its technical training, knowledge and experience, qualified personnel is able to perform the delegated tasks, recognize and avoid possible dangers and knows the relevant standards and regulations.

Instructed person

Instructed persons were instructed by the operator about the delegated tasks and possible dangers due to improper behaviour.

Service personnel of the manufacturer

Due to its technical training, knowledge and experience, service personnel of the manufacturer is able to perform the delegated tasks and to recognize and avoid possible dangers.

2.7 Personal protective equipment

Use of personal protective equipment

Personal protective equipment serves to protect staff against danger which may interfere with their health or safety at work.

- When working on and with the product, observe the occupational health and safety regulations and wear the required personal protective equipment.
- Observe the valid safety and accident prevention regulations.
- Wear protective gloves to guard against sharp edges and corners or rough surfaces.
- Wear heat-resistant protective gloves when handling hot surfaces.
- Wear protective gloves and safety goggles when handling hazardous substances.
- Wear close-fitting protective clothing and also wear long hair in a hairnet when dealing with moving components.

2.8 Notes on safe operation

Incorrect handling of the personnel

Incorrect handling and assembly may impair the product's safety and cause serious injuries and considerable material damage.

- Avoid any manner of working that may interfere with the function and operational safety of the product.
- Use the product as intended.
- Observe the safety notes and assembly instructions.
- Do not expose the product to any corrosive media. This does not apply to products that are designed for special environments.
- Eliminate any malfunction immediately.
- Observe the care and maintenance instructions.
- Observe the current safety, accident prevention and environmental protection regulations regarding the product's application field.

2.9 Transport

Handling during transport

Incorrect handling during transport may impair the product's safety and cause serious injuries and considerable material damage.

- When handling heavy weights, use lifting equipment to lift the product and transport it by appropriate means.
- Secure the product against falling during transportation and handling.
- Stand clear of suspended loads.

2.10 Malfunctions

Behavior in case of malfunctions

- Immediately remove the product from operation and report the malfunction to the responsible departments/persons.
- Order appropriately trained personnel to rectify the malfunction.
- Do not recommission the product until the malfunction has been rectified.
- Test the product after a malfunction to establish whether it still functions properly and no increased risks have arisen.

2.11 Disposal

Handling of disposal

The incorrect handling of disposal may impair the product's safety and cause serious injuries as well as considerable material and environmental harm.

- Follow local regulations on dispatching product components for recycling or proper disposal.

2.12 Fundamental dangers

General

- Observe safety distances.
- Never deactivate safety devices.
- Before commissioning the product, take appropriate protective measures to secure the danger zone.
- Disconnect power sources before installation, modification, maintenance, or calibration. Ensure that no residual energy remains in the system.
- If the energy supply is connected, do not move any parts by hand.
- Do not reach into the open mechanism or movement area of the product during operation.

2.12.1 Protection during handling and assembly

Incorrect handling and assembly

Incorrect handling and assembly may impair the product's safety and cause serious injuries and considerable material damage.

- Have all work carried out by appropriately qualified personnel.
- For all work, secure the product against accidental operation.
- Observe the relevant accident prevention rules.
- Use suitable assembly and transport equipment and take precautions to prevent jamming and crushing.

Incorrect lifting of loads

Falling loads may cause serious injuries and even death.

- Stand clear of suspended loads and do not step into their swiveling range.
- Never move loads without supervision.
- Do not leave suspended loads unattended.

2.12.2 Protection during commissioning and operation

Falling or violently ejected components

Falling and violently ejected components can cause serious injuries and even death.

- Take appropriate protective measures to secure the danger zone.
- Never step into the danger zone during operation.

2.12.3 Protection against dangerous movements

Unexpected movements

Residual energy in the system may cause serious injuries while working with the product.

- Switch off the energy supply, ensure that no residual energy remains and secure against inadvertent reactivation.
- Never rely solely on the response of the monitoring function to avert danger. Until the installed monitors become effective, it must be assumed that the drive movement is faulty, with its action being dependent on the control unit and the current operating condition of the drive. Perform maintenance work, modifications, and attachments outside the danger zone defined by the movement range.
- To avoid accidents and/or material damage, human access to the movement range of the machine must be restricted. Limit/prevent accidental access for people in this area due through technical safety measures. The protective cover and protective

fence must be rigid enough to withstand the maximum possible movement energy. EMERGENCY STOP switches must be easily and quickly accessible. Before starting up the machine or automated system, check that the EMERGENCY STOP system is working. Prevent operation of the machine if this protective equipment does not function correctly.

2.13 Notes on particular risks



⚠ DANGER

Risk of fatal injury from suspended loads!

Falling loads can cause serious injuries and even death.

- Stand clear of suspended loads and do not step within their swiveling range.
- Never move loads without supervision.
- Do not leave suspended loads unattended.
- Wear suitable protective equipment.



⚠ WARNING

Risk of injury from objects falling and being ejected!

Falling and ejected objects during operation can lead to serious injury or death.

- Take appropriate protective measures to secure the danger zone.



⚠ WARNING

Risk of injury from sharp edges and corners!

Sharp edges and corners can cause cuts.

- Use suitable protective equipment.



⚠ WARNING

Risk of injury due to unexpected movements!

If the power supply is switched on or residual energy remains in the system, components can move unexpectedly and cause serious injuries.

- Before starting any work on the product: Switch off the power supply and secure against restarting.
- Make sure, that no residual energy remains in the system.



⚠ WARNING

Risk of injury from crushing and impacts!

Serious injury could occur during movement of the base jaw, due to breakage or loosening of the gripper fingers or if the workpiece is lost.

- Wear suitable protective equipment.
- Do not reach into the open mechanism or the movement area of the product.



⚠ WARNING

Risk of injury due to spring forces!

Parts are under spring tension on products which clamp using spring force or which have gripping force maintenance. While disassembling components can move unexpectedly and cause serious injuries.

- Disassemble the product cautiously.
- Make sure that no residual energy remains in the system.



⚠ WARNING

Risk of injury from objects falling during energy supply failure

Products with a mechanical gripping force maintenance can, during energy supply failure, still move independently in the direction specified by the mechanical gripping force maintenance.

- Secure the end positions of the product with SCHUNK SDV-P pressure maintenance valves.

3 Technical data

Size	ORG 85
Weight [kg]	1.35
Ring diameter external installation [mm]	ca. Ø5 ... Ø160
Ring diameter internal installation [mm]	ca. Ø20 ... Ø120
Number of fingers	6
Max. permissible finger length [mm]	80.0
Jaw triple A	
Operating principle	double acting
Stroke per jaw [mm]	21.0
Closing force [N]	45.0
Opening force [N]	55.0
Retraction stroke [mm]	5.0
Return force [N]	20.0
Jaw triple B	
Operating principle	single acting
Stroke per jaw [mm]	15.0
Opening force [N]	125.0
Pressure medium	Compressed air, compressed air quality according to ISO 8573-1:2010 [7:4:4]
Nominal working pressure [bar]	6.0
Min. pressure [bar]	4.0
Max. pressure [bar]	8.0
IP rating	40
Noise emission [dB(A)]	≤ 70
Min. ambient temperature [°C]	- 10
Max. ambient temperature [°C]	+90
Repeatability [mm]	0.02

More technical data is included in the catalog data sheet.
Whichever is the latest version.

4 Assembly and installation

4.1 Installing and connecting



⚠ WARNING

Risk of injury due to unexpected movements!

If the power supply is switched on or residual energy remains in the system, components can move unexpectedly and cause serious injuries.

- Before starting any work on the product: Switch off the power supply and secure against restarting.
- Make sure, that no residual energy remains in the system.

NOTICE

Risk of damage to the gripper!

If the maximum permissible finger weight or the permissible mass moment of inertia of the fingers is exceeded, the gripper can be damaged.

- As a rule, a jaw movement must take place without impact and bouncing.
- To do this, carry out sufficient throttling and/or damping if necessary.
- Observe specifications in the catalog data sheet.

1. Check the evenness of the mounting surface, ▶ 4.2.1 [19].
2. Screw the product to the machine/system, ▶ 4.2.1 [19].
3. Connect compressed air supply line to the main air connection, ▶ 4.2.2 [20].
4. If necessary, select gripper finger, ▶ 1.4.2 [8]
5. Secure the gripper fingers to the base jaws, ▶ 4.4 [21].
6. Adjust the end positions of the triple jaws A and B, ▶ 4.5 [29]
7. Mount sensor if necessary, ▶ 4.6 [31].

4.2 Connections

4.2.1 Mechanical connection

Evenness of the mounting surface

The values apply to the whole mounting surface to which the product is mounted.

Edge length	Permissible unevenness
< 100	< 0.02
> 100	< 0.05

Tab.: Requirements for evenness of the mounting surface (Dimensions in mm)

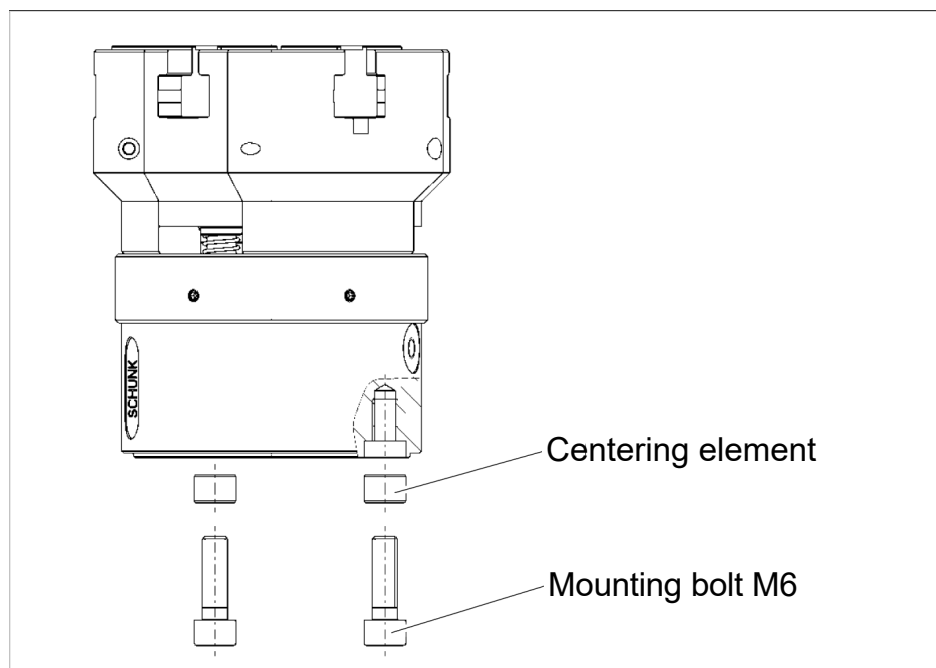

Mounting the gripper

Mount the product with the fastening threads intended for this purpose (at the base of the gripper).

The centering elements required to mount the gripper are included in the scope of delivery.

The necessary mounting screws are not included in the scope of delivery.

4.2.2 Pneumatic connection

NOTICE

Damage to the gripper fingers if the operating pressure is too high.

During internal assembly in the range from $d_1=10$ mm to $d_1=15$ mm, or when working with an assembly finger with a width of less than 2 mm, the operating pressure of triple jaw A must be reduced to max. 2.5 bar! If the operating pressure is not reduced, the as-sembly fingers could be damaged or destroyed.

NOTE

- Observe the requirements for the compressed air supply, ▶ 3 [17].
- In case of compressed air loss (cutting off the energy line), the components lose their dynamic effects and do not remain in a secure position. However, the use of a SDV-P pressure maintenance valve is recommended in this case in order to maintain the dynamic effect for some time. Product variants are also offered with mechanical gripping force via springs, which also ensure a minimum clamping force in the event of a pressure drop.

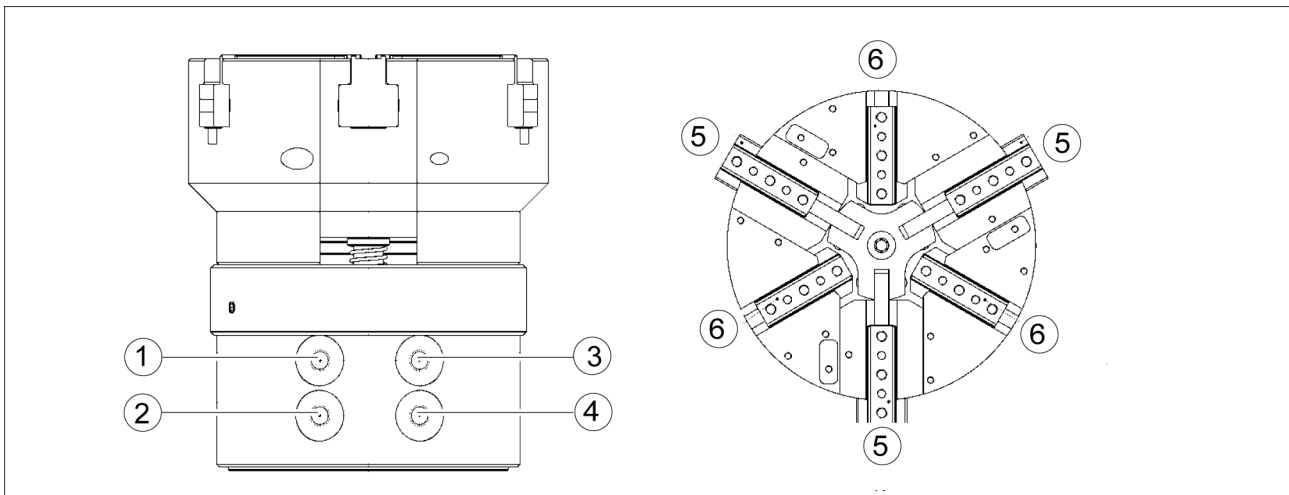

Definition of air connections and triple jaws

Item	Designation	Thread size
1	Close triple jaw A air connection	M5
2	Z-stroke air connection	M5
3	Open triple jaw A air connection	M5
4	Open triple jaw B air connection	M5
5	Triple jaw A (designates the three base jaws which are pulled downwards in axial direction by the Z stroke)	-
6	Triple jaw B (designates the three base jaws which do not change their height position)	-

4.3 Transfer point seal

NOTE

To allow the reliable reception of the seal, a transfer point must be defined.

The transfer point of the seal is to be designed as follows:

1. The seal must be prepositioned on a plane parallel to the direction of movement of the triple jaws.
2. The centre axis of the seal is to be concentric with the centre axis of the O-ring gripper.
3. Furthermore, the seal, as far as possible by means of separation, should be provided in a round shape especially for large seal diameters to be assembled and for internal assembly.
4. The assembly fingers and segment jaws must have sufficient space at the transfer point to pick up the seal.

4.4 Installing gripper fingers

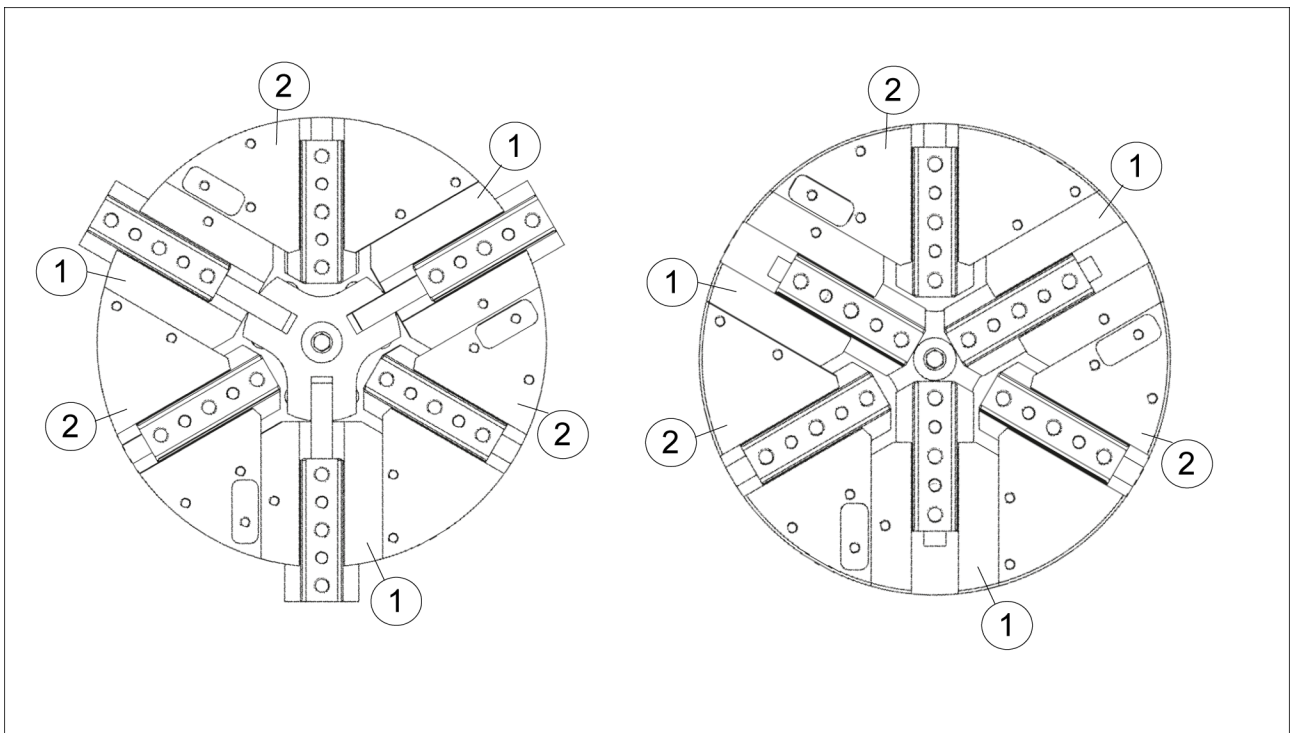

Left: Triple jaw A "open" and triple jaw B "closed"; Right: Triple jaw A and B closed (gripper closed)

1 Triple jaw A

2 Triple jaw B

4.4.1 External assembly inner seal diameter between $d1=10$ mm and $d1=60$ mm

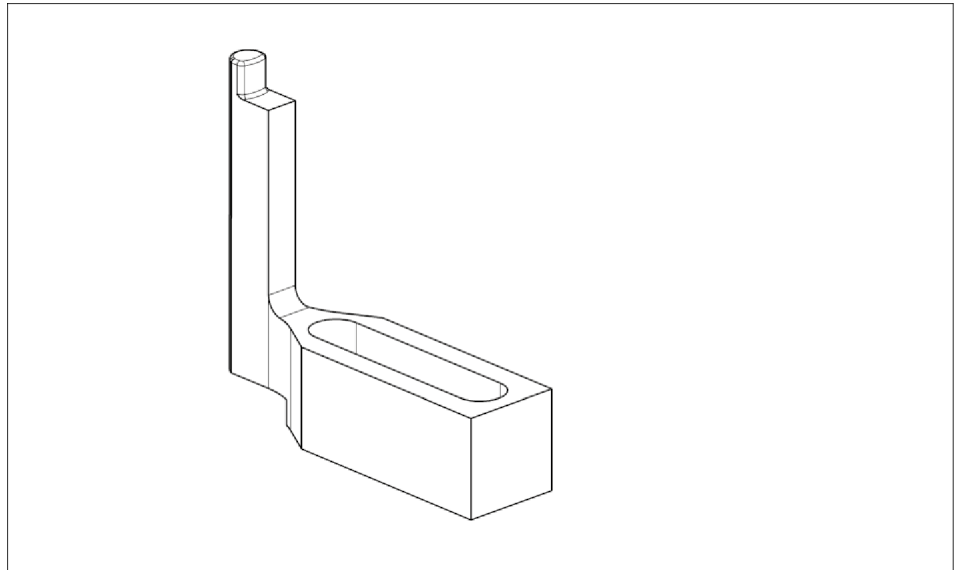

Gripper finger external assembly MFA

- Six gripper fingers are required for external assembly.
- Triple jaw A and triple jaw B are closed.
- Compressed air connection (1) is pressurized, compressed air connection (4) is not pressurized.
- Compressed air connection (2) is not pressurized, i.e. the Z-stroke is in the upper position.

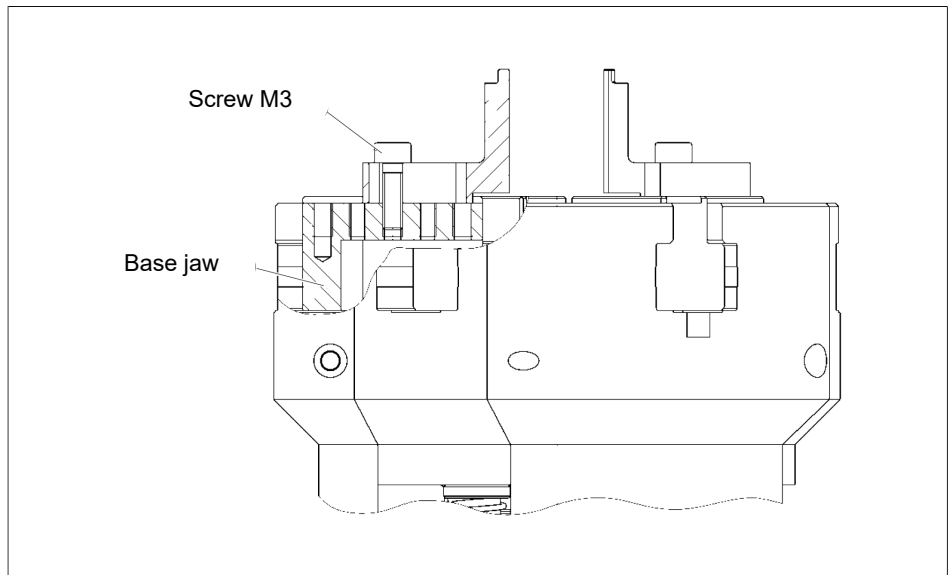

Mounting gripper finger external assembly; inner seal diameter between $d1=10$ mm and $d1=60$ mm

NOTE

If inductive monitoring is used, attach intermediate jaws to the base jaws. The cams on the intermediate jaws must point outwards, ► 4.6 [31].

1. Screw the gripper fingers onto the base jaws using one / two M-3 screw(s) each.
2. In doing so, observe the following:

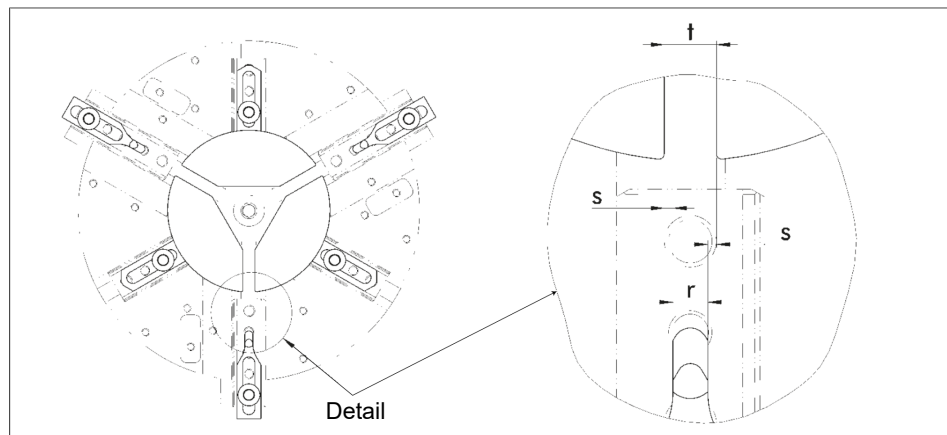

Settings of the gripper fingers and segment jaws

- ⇒ When the triple jaw A is open, the gripper fingers must be outside the seal at a defined distance (dimension o) from the seal.

NOTE

The dimension t must be at least larger than the tip of the gripper finger (dimension r) plus two safety distances (dimension s). A reliable assembly process is guaranteed if the safety distance (dimension s) is set as small as possible (value range $s = 0.1 \text{ mm} < s < 0.3 \text{ mm}$).

- ⇒ When the triple jaw B is closed, the segment jaws must be joined to one another at a defined distance (dimension t).
- ⇒ The circumferential circle of the three segment jaws (dimension $\varnothing p$) must be smaller than the inner diameter d_2 of the seal.
- ⇒ When the triple jaw A is closed, the gripper fingers must have moved far enough inwards that the seal lies cleanly around the segment jaws and is slightly stretched in the area of the gripper fingers.

NOTE

Further information on the assembly and function of the product from chapter ▶ 5.2 [44].

4.4.2 External assembly inner seal diameter between $d_1 > d_{1max}$. and $d_1 = 150$ mm

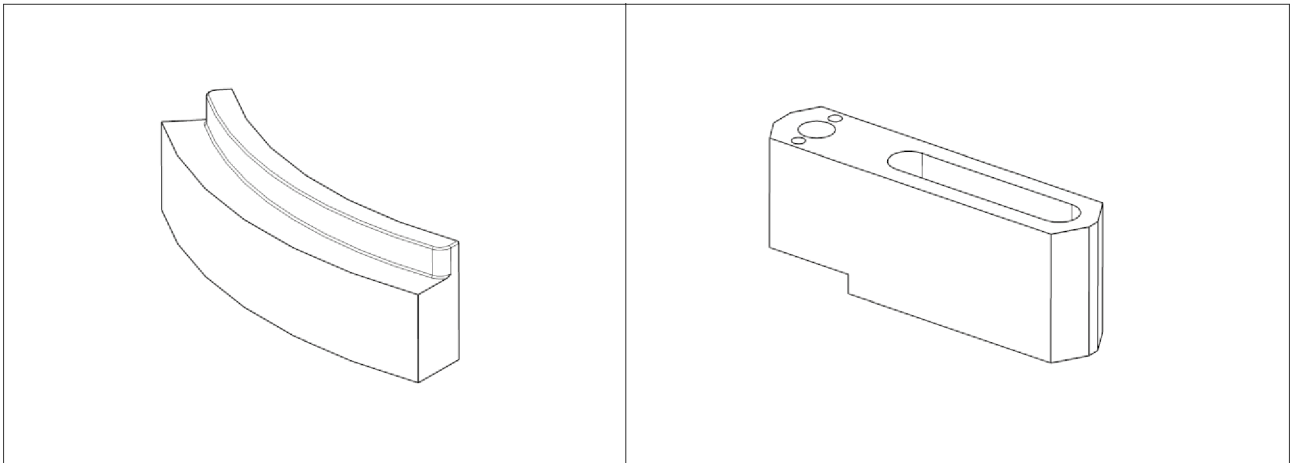

Left: Segment jaw for external mounting SBA; Right: Clamping jaw for external assembly HBA

- Six segment jaws and six clamping jaws are required for external assembly.
- Triple jaw A and triple jaw B are closed.
- Compressed air connection (1) is pressurized, compressed air connection (4) is not pressurized.
- Compressed air connection (2) for Z-stroke is depressurized.

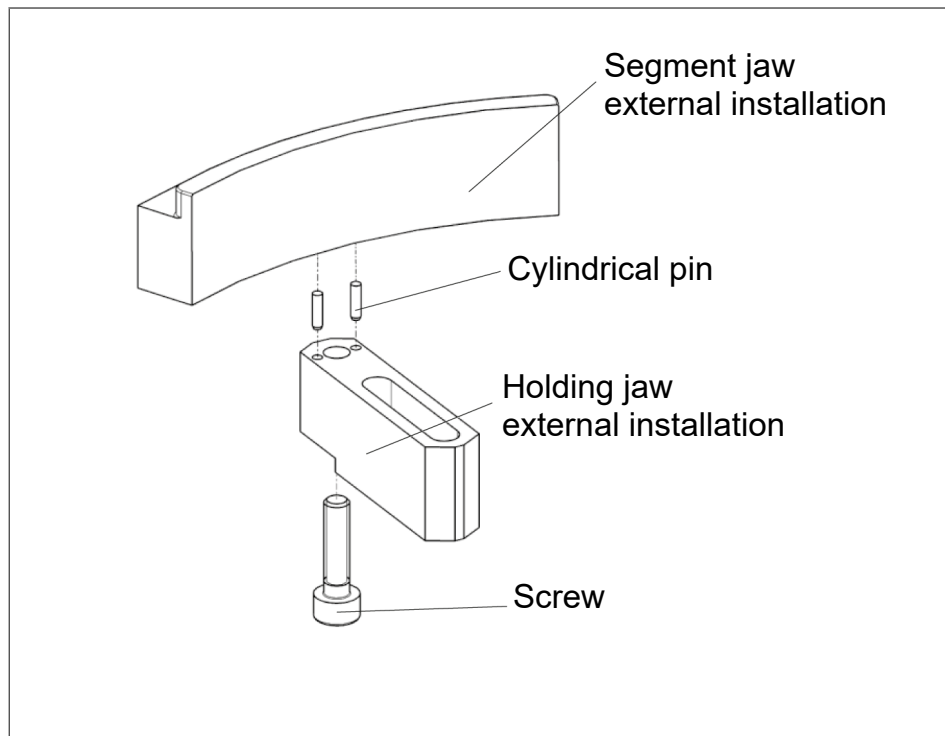

Assembly of segment jaw with clamping jaw

NOTE

If inductive monitoring is used, attach intermediate jaws to the base jaws. The cams on the intermediate jaws must point outwards, ► 4.6 [31].

1. Connect segment jaws and six clamping jaws with cylindrical pins.
2. Connect both parts with a screw so they can be separated.

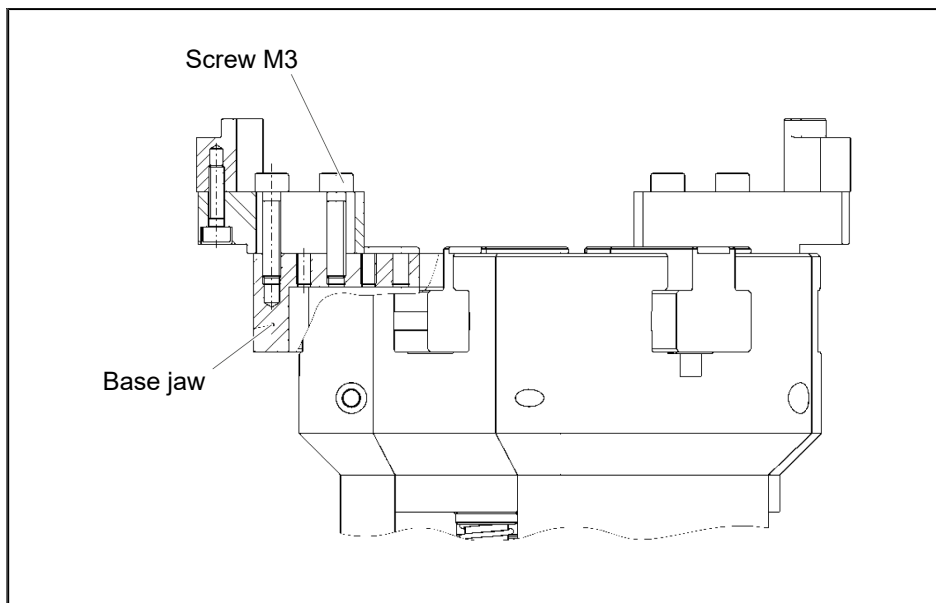

Mounting segment jaws with clamping jaws external assembly, range of inside seal diameter $d_1 > 60$ mm to approx. $d_1 = 150$ mm

3. Screw the top jaws onto the base jaws using one / two M-3 screw(s) each.
4. In doing so, observe the following:

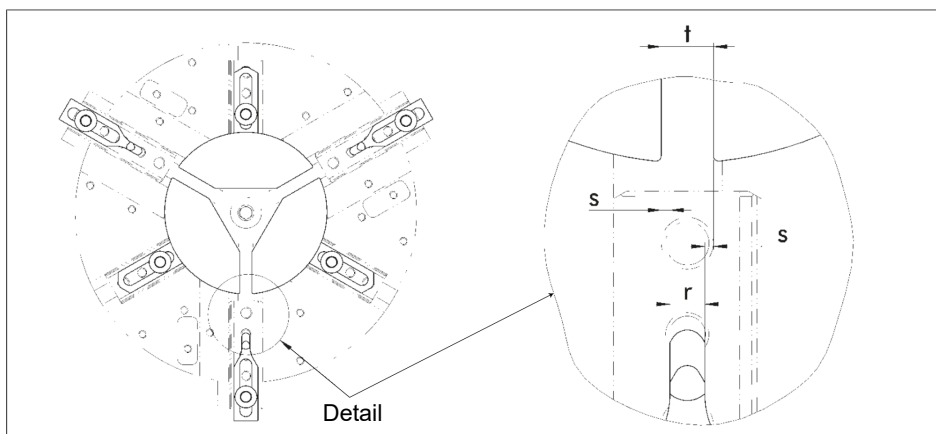

Settings of the gripper fingers and segment jaws

- ⇒ When the triple jaw A is open, the gripper fingers must be outside the seal at a defined distance (dimension o) from the seal.

NOTE

The dimension t must be at least larger than the tip of the gripper finger (dimension r) plus two safety distances (dimension s). A reliable assembly process is guaranteed if the safety distance (dimension s) is set as small as possible (value range $s = 0.1 \text{ mm} < s < 0.3 \text{ mm}$).

- ⇒ When the triple jaw B is closed, the segment jaws must be joined to one another at a defined distance (dimension t).
- ⇒ The circumferential circle of the three segment jaws (dimension $\emptyset p$) must be smaller than the inner diameter d_2 of the seal.
- ⇒ When the triple jaw B is closed, the segment jaws must be joined to one another at a defined distance (dimension t).

NOTE

Further information on the assembly and function of the product from chapter ▶ 5.2 [44].

4.4.3 Internal assembly inner seal diameter between $d1=20$ mm and $d1\approx 120$ mm

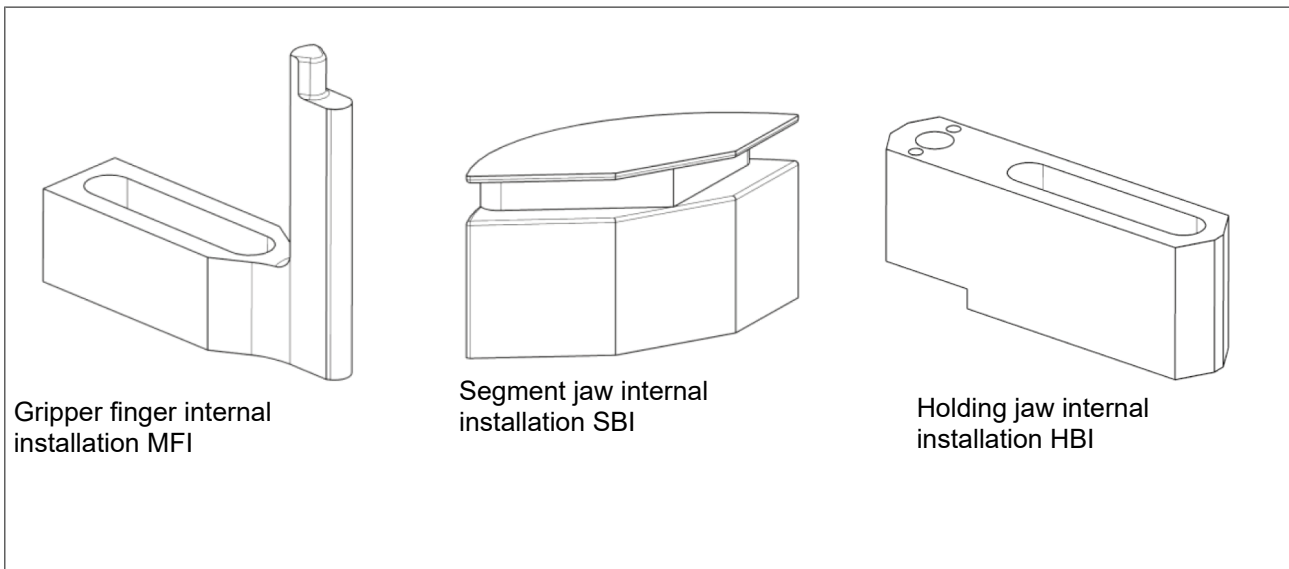

Gripper finger, segment jaw and clamping jaw for internal assembly (MFI, SBI, HBI)

- For internal assembly three gripper fingers for internal assembly, three segment jaws for internal assembly and three clamping jaws for internal assembly are required.
- Triple jaw A is open and the compressed air connection (3) is pressurized.
- Triple jaw B is closed and the compressed air connection (4) is not pressurized.

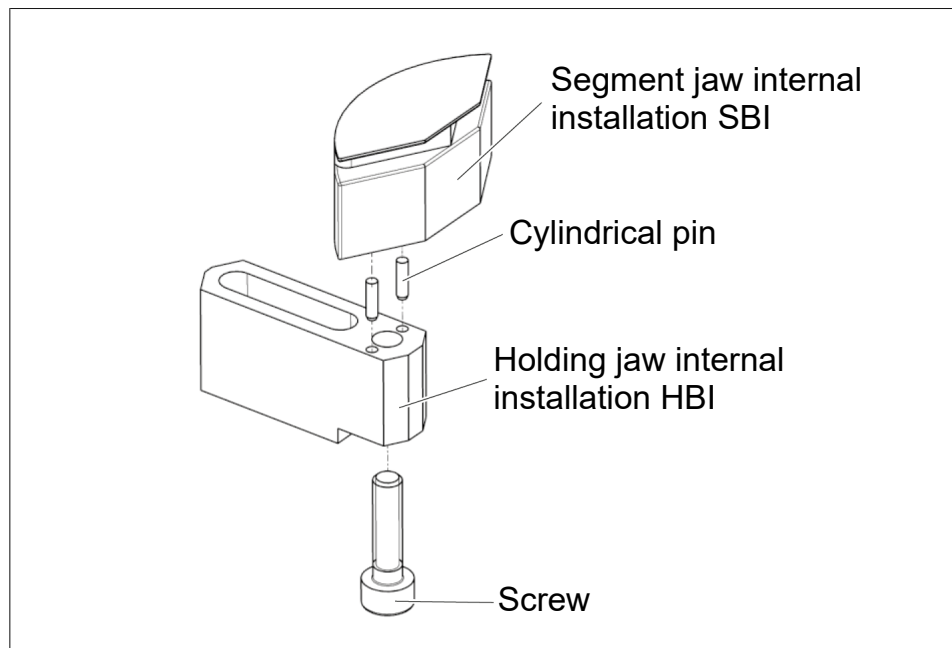

Installation of segment and clamping jaw for internal assembly

NOTE

If inductive monitoring is used, attach intermediate jaws to the base jaws. The cams on the intermediate jaws must point outwards, ► 4.6 [31].

1. Connect segment jaws and six clamping jaws with cylindrical pins.
2. Connect both parts with a screw so they can be separated.

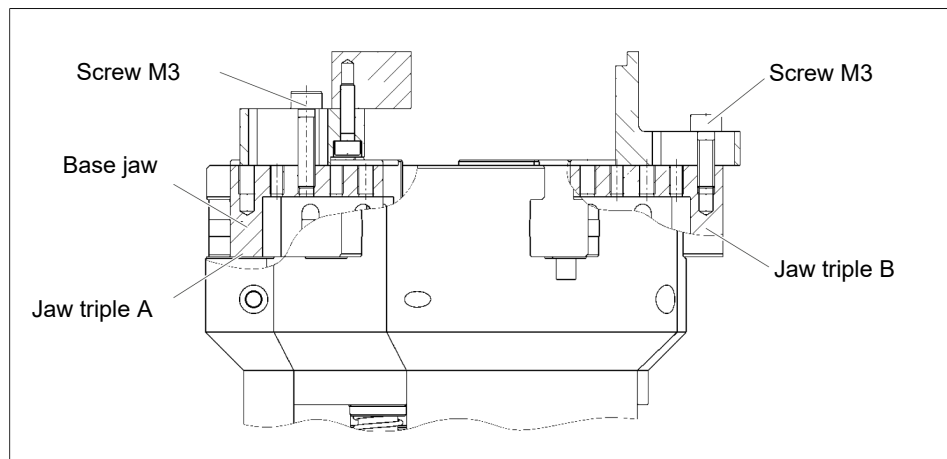

Fastening of gripper fingers and segment jaws with clamping jaws for internal assembly

3. Attach the gripper fingers to the triple jaw A with one / two M3 screws each.
4. Attach the segment jaws connected to the clamping jaws to the base jaws triple jaw B with one / two M3 screws each.
5. In doing so, observe the following:

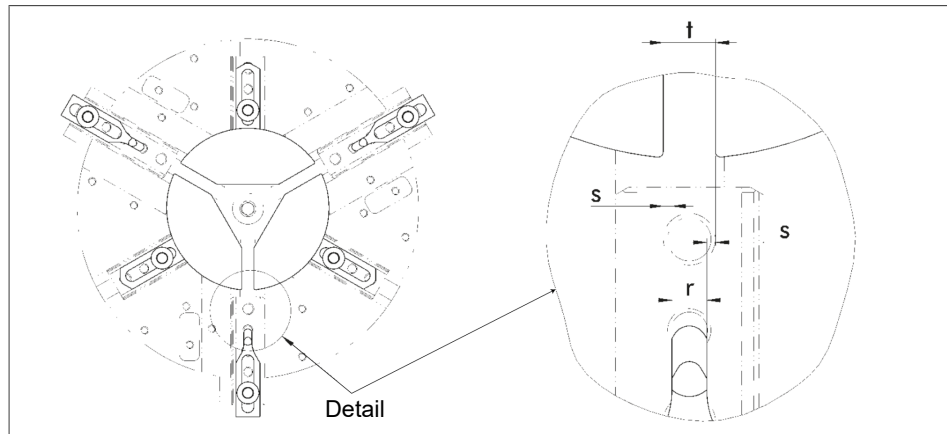

Settings of the gripper fingers and segment jaws

- ⇒ When the triple jaw A is open, the gripper fingers must be outside the seal at a defined distance (dimension o) from the seal.

NOTE

The dimension t must be at least larger than the tip of the gripper finger (dimension r) plus two safety distances (dimension s). A reliable assembly process is guaranteed if the safety distance (dimension s) is set as small as possible (value range $s = 0.1 \text{ mm} < s < 0.3 \text{ mm}$).

- ⇒ When the triple jaw B is closed, the segment jaws must be joined to one another at a defined distance (dimension t).
- ⇒ The circumferential circle of the three segment jaws (dimension $\varnothing p$) must be smaller than the inner diameter d_2 of the seal.
- ⇒ When the triple jaw A is closed, the gripper fingers must have moved far enough inwards that the seal lies cleanly around the segment jaws and is slightly stretched in the area of the gripper fingers.

NOTE

Further information on the assembly and function of the product from chapter ▶ 5.5 [58].

4.5 Setting the end positions



⚠ WARNING

Risk of injury when the machine/system moves unexpectedly.
Remove the energy supplies.

NOTE

The piston rod (2) can be adjusted with max. 0.8 Nm!

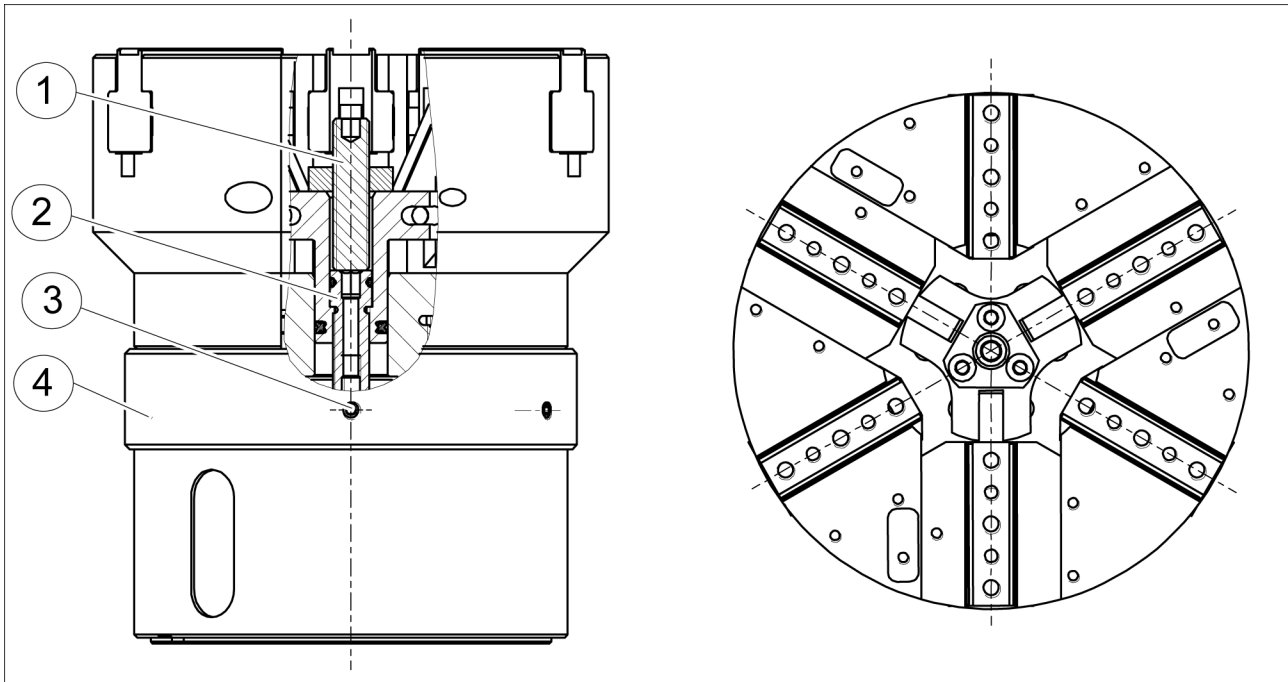

Setting the end positions

Item	Designation	Notes
1	Set screw	-
2	Piston rod – Adjustment triple jaw A stroke	SW 3
3	Set screws to counter the stroke adjustment ring	SW 1,5
4	Stroke adjustment ring – Adjustment triple jaw B stroke	-

Adjustment triple jaw A stroke

NOTE

To secure the piston rod (2) against rotation, it is necessary to counter it by screwing in the previously removed set screw (1)!

The stroke limitation of triple jaw A is performed by adjusting the piston rod (2).

- The set screw (1) must be removed before adjusting the piston rod (2).

1. The stroke of triple jaw A is increased by turning the piston rod (2) clockwise.
2. The stroke of triple jaw A is reduced by turning the piston rod (2) counterclockwise.

Adjustment triple jaw B stroke

Both counter set screws (3) must be loosened before adjusting the stroke of triple jaw B! They must be unscrewed from the stroke adjustment ring (4) until the ring (4) can be turned!

The stroke of triple jaw B can be adjusted after both counter set screws (3) have been loosened.

1. The stroke of triple jaw B is performed by adjusting the stroke adjustment ring (4). The stroke of triple jaw B is increased by turning the stroke adjustment ring (4) clockwise.
2. The stroke of triple jaw B is reduced by turning the stroke adjustment ring (4) counterclockwise.
3. After the desired stroke has been set, the stroke adjustment ring (4) must be secured against unintentional turning using one of the two counter set screws (3) (depending on the angle of turning, it may not be possible to clamp both set screws against the base body triple jaw B).
4. If the stroke adjustment ring (4) cannot be turned despite loosening the counter set screws (3) proceed as follows:
Repeatedly actuate triple jaw B open and closed.
Subsequently, the stroke adjustment ring (4) should be able to be easily rotated by hand again.

NOTICE

Carefully tighten the counter set screw using only your hand. If it is tightened too much, assembly group 1 may become jammed as a result ▶ 7.5 [76].

5. Proceed as follows if triple jaw B does not open up after turning the stroke adjustment ring (4):
 - ⇒ Disconnect gripper from the energy supply
 - ⇒ Loosen the counter set screws (3)
 - ⇒ Slightly turn the stroke adjustment ring (4) in the direction opposite to the one last rotated
 - ⇒ Retighten the counter set screws (3)

4.6 Mounting the sensor

NOTE

Observe the assembly and operating manual of the sensor for mounting and connecting.

The product is prepared for the use of sensors.

- For the exact type designations of suitable sensors, please see catalog datasheet and ▶ 4.6.1 [📄 31].
- For technical data for the suitable sensors, see assembly and operating manual and catalog datasheet.
 - The assembly and operating manual and catalog datasheet are included in the scope of delivery for the sensors and are available at [schunk.com](https://www.schunk.com).
- Information on handling sensors is available at [schunk.com](https://www.schunk.com) or from SCHUNK contact persons.

4.6.1 Overview of sensors

Designation	ORG
	85
Inductive proximity switch IN 30	X

4.6.2 Assembly drawing mounting kit

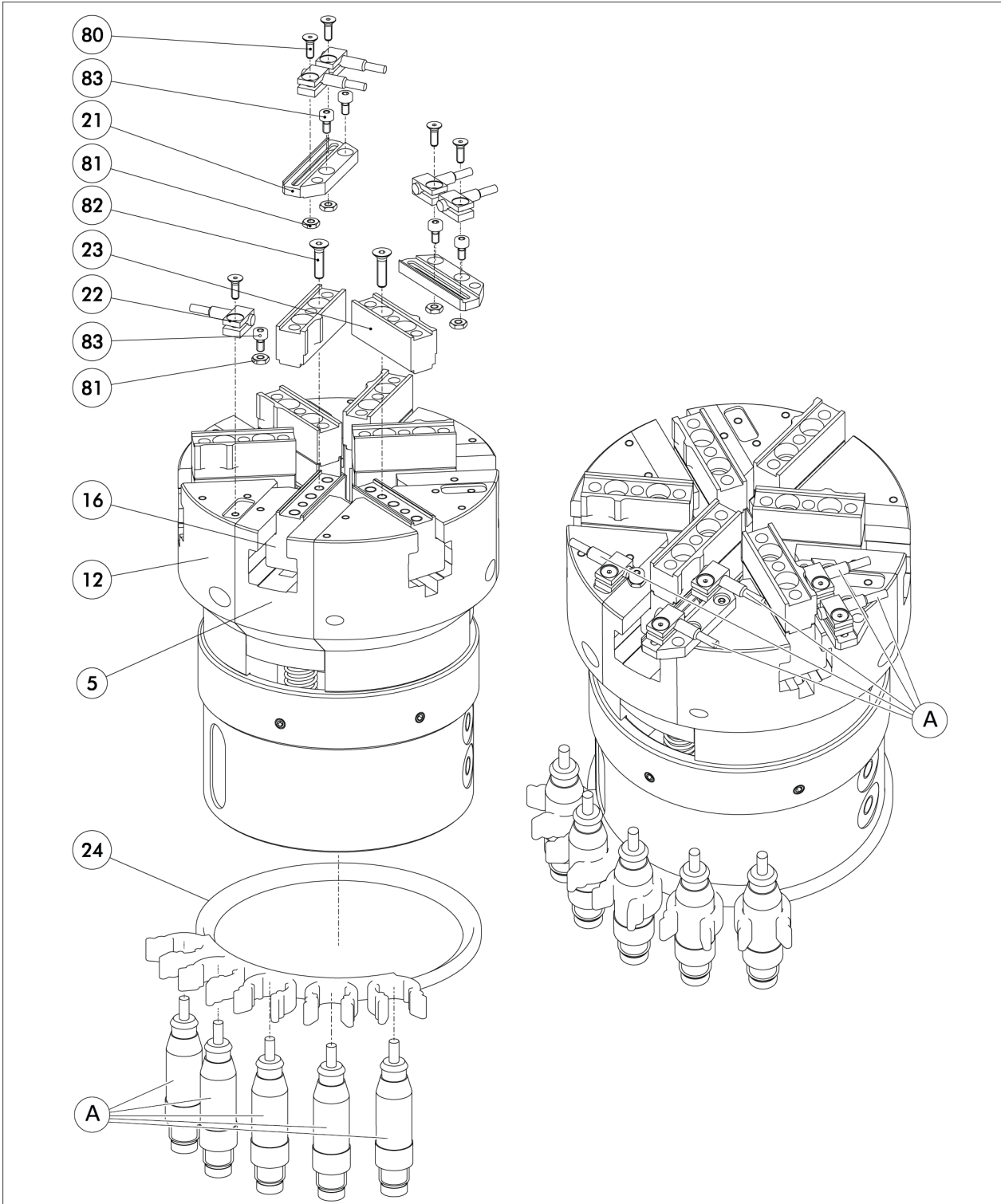

Assembly drawing mounting kit

Item	ID number	Quantity	Designation
A	1001272	1	Inductive proximity switch IN 30
21	5516232	2	Holding plate monitoring triple jaws A and B
22	5516233	5	Bracket
23	5516234	6	Intermediate jaw
24	1399682	1	Bracket NHS cable ORG 85
80	1431285	5	Countersunk screw M2 x 6
81	9690010	5	Nut M2
82	9682803	6	Countersunk screw M2.5 x 10
83	9938910	5	Screw M2 x 4

4.6.3 Mounting inductive proximity switch IN 30

NOTICE

Damage to the proximity switches possible!

The proximity switches can be damaged or destroyed by incorrect settings.

- Avoid incorrect setting of the proximity switches
- Avoid collisions

With the inductive proximity switch IN 30, the Z-stroke and the triple jaws A or B can be monitored

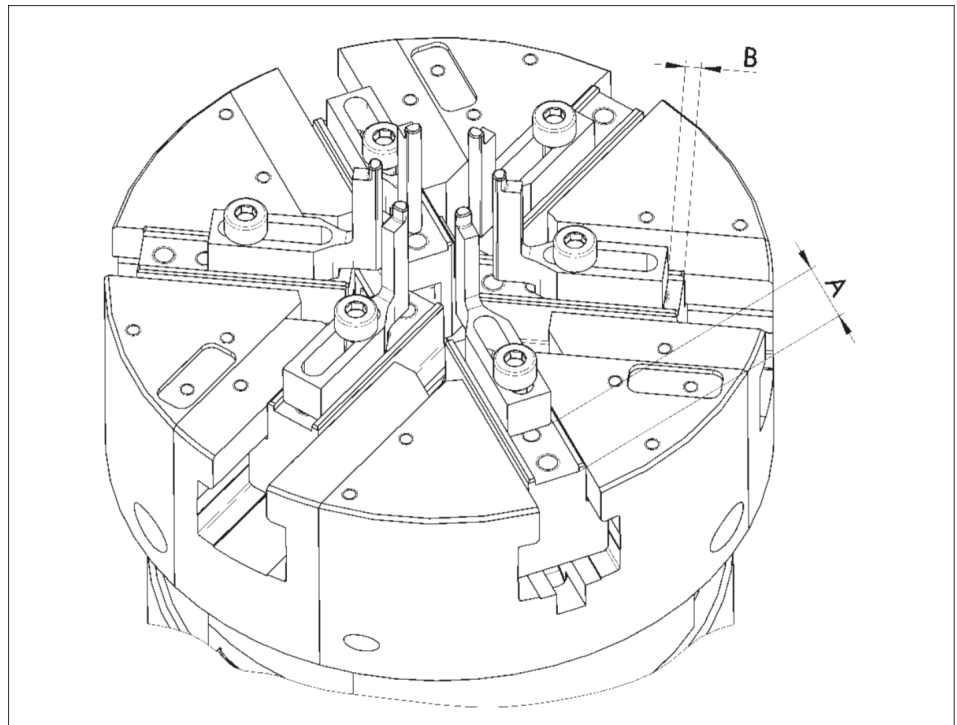

Distance between gripper finger and base jaw

Initial commissioning of the product

Subsequent assembly

- Intermediate jaws (23) were mounted.
 - Mount and adjust the proximity switch.
- Top jaws are already mounted:
 1. Measure distances A and B from the rear edge of the base jaws (16) to the top jaws and note these values.
 2. Disassemble all top jaws.
 3. Attach intermediate jaws (23) to the base jaws with a screw (82).
The cams on the intermediate jaws must point outwards.
 4. Mount and adjust the proximity switch.
 5. Installing the top jaws.
 6. Observe and adhere to noted distances A and B.

4.6.3.1 Adjusting Z-stroke monitoring

Position of the item numbers, ▶ 4.6.2 [32]

NOTE

Fastening of the brackets (22) with the proximity switches: The max. tightening torque of the M2 fastening screws (80) is 0.1 Nm! If the screws are tightened too much, there is a danger that the sensor will be damaged and will no longer deliver a signal!

1. Screw the nut (81) onto the screw (83).
2. Fix the screw (83) with the nut (81) in one of the three base bodies triple jaw A (5).
3. Push the proximity switch into the bracket (22).
4. By tightening a screw (80), fasten the bracket (22) in the pocket milled out of the base body triple jaw B (12). Observe the max. tightening torque of 0.1 Nm. The bracket (22) with the proximity switch must be fastened directly next to the screw (83) fastened in the first step.
5. Adjust the screw (83) so that its head dampens the proximity switch S5. Secure the axial position of the screw (83) by locking the nut (81). Note that the screw (83) must no longer be damped when pulling the Z-stroke!

The proximity switch must be adjusted so that the distance between sensor and screw head (83) is approx. 0.2 – 0.4 mm.

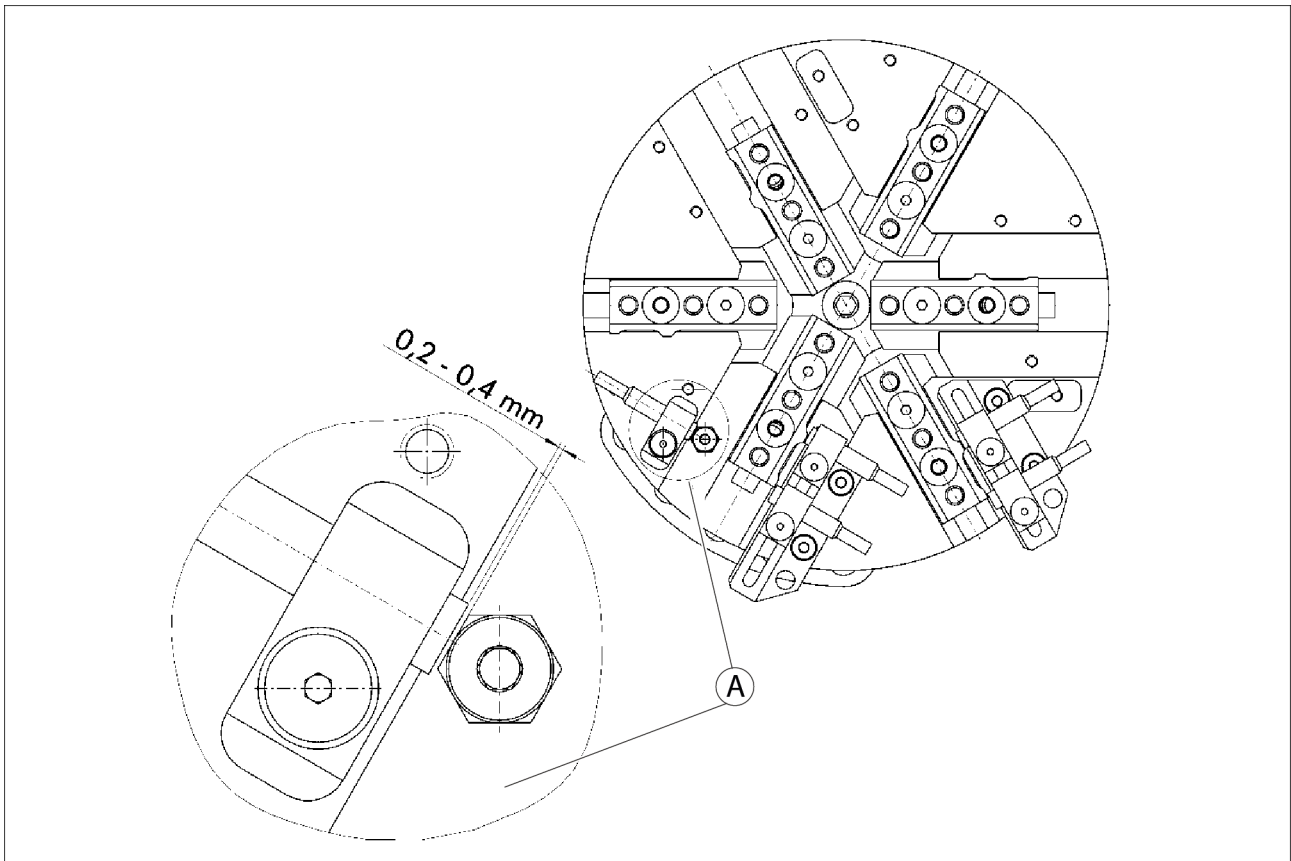

Z-stroke monitoring

A

Detail A

The proximity switch is only damped by the screw (83) when the Z-stroke is in the end position (Z-stroke "up", compressed air connection (2) ▶ 4.2.2 [□ 20] not pressurized).

4.6.3.2 Adjusting triple jaws A or B monitoring

Position of the item numbers, ▶ 4.6.2 [□ 32]

1. Insert two nuts (81) into the slot in the holding plate for the triple jaws A and B (21) monitoring.
2. Push the proximity switch into the bracket (22).
3. Fasten both brackets (22) to the holding plate (21) by tightening the screw (80) with the previously inserted nuts (81).
4. Secure the holding plate (21) by tightening with two screws (83) on the base body triple jaws A (5) or triple jaws B (12). The holding plate (21) must be fastened directly next to the Z-stroke or triple jaw A monitoring to facilitate cable routing.

The proximity switch must be set so that the distance between sensor and cam intermediate jaw (23) is approx. 0.2 - 0.4 mm.

Step 1 (Example Gripper closed 0 mm "OPEN")

1. Proximity switch S1 only monitors the position "Gripper closed". This must be set so that it is damped by cam 1 (1 mm high) in the "gripper closed" state.
2. Proximity switch S2 monitors the position "Gripper open". This must be set so that it is not damped by cam 2 (0.5 mm high) in the "gripper closed" state.

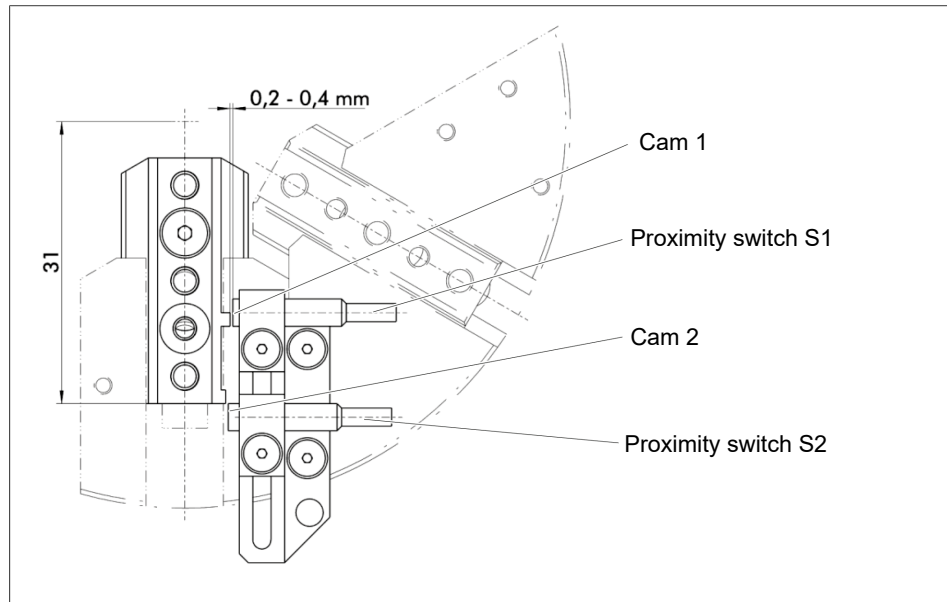
*Step 1 Setting the proximity switches***NOTE**

Make sure that the proximity switches S2 and S4 are not damaged or destroyed by cam 1 due to incorrect stroke settings (a too large opening stroke)!

Step 2 (Example Gripper open 1 mm "OPEN")

1. Proximity switch S1 is no longer damped by cam 1 (1 mm high).
2. Proximity switch S2 is now damped by cam 2 (0.5 mm high).

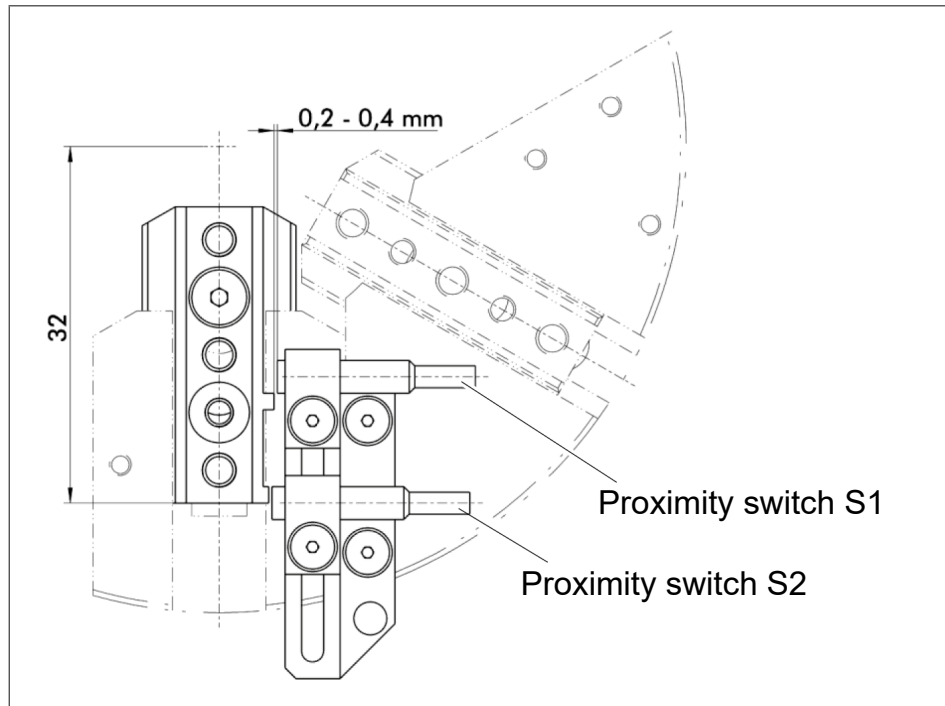

Step 2 Setting the proximity switches

Step 3 (Example Gripper open approx. 9 mm "OPEN")

1. Proximity switch S1 is not damped.
2. Proximity switch S2 is damped by cam 2 (0.5 mm high).

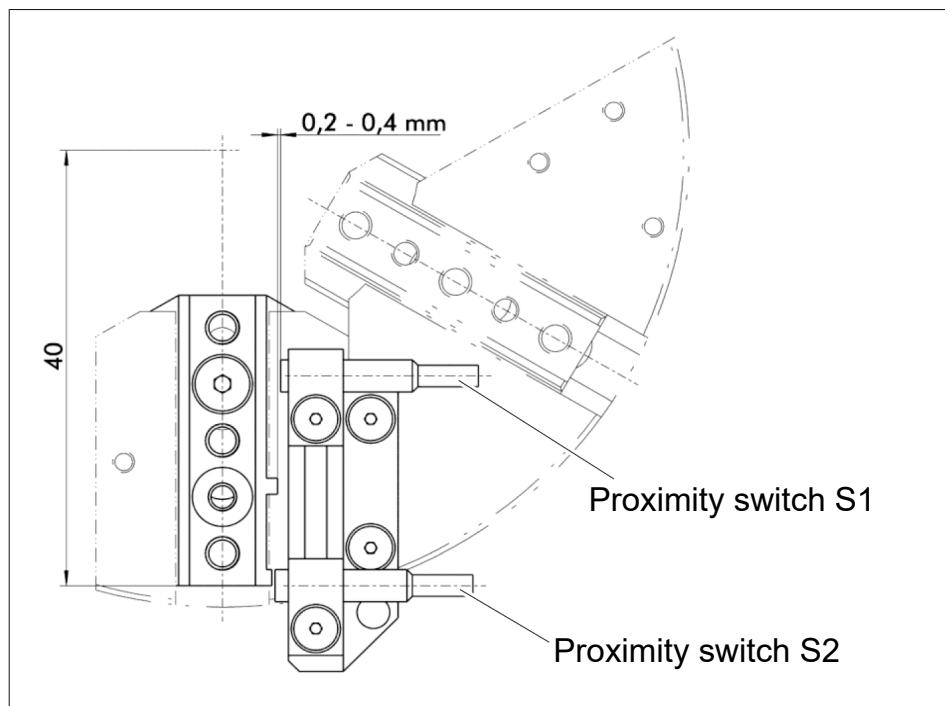

Step 3 Setting proximity switch

3. The position of the proximity switch S2 on the holding plate (21) can no longer be adjusted radially outwards. The proximity switch must be released from the bracket (22) in

order to monitor further "Gripper OPEN" positions. The bracket (22) must be rotated 180° and the proximity switch then fastened again in the bracket (22) ▶ 4.6.3 [34].

Step 4 (Example Gripper open approx. 9 mm "OPEN", bracket rotated 180°)

1. Proximity switch S1 is not damped.
2. Proximity switch S2 is damped by cam 2 (0.5 mm high).

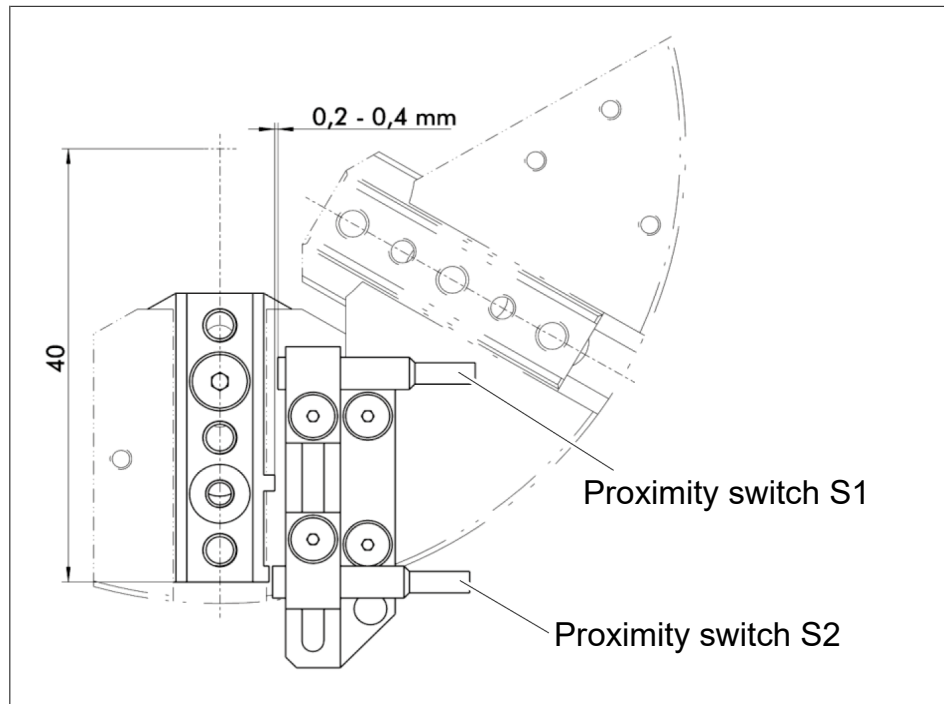

Step 4 Setting the proximity switches

Step 5 (Example: Gripper open, approx. 17 mm "OPEN", bracket rotated 180°)

1. Proximity switch S1 is not damped.
2. Proximity switch S2 is damped by cam 2 (0.5 mm high).

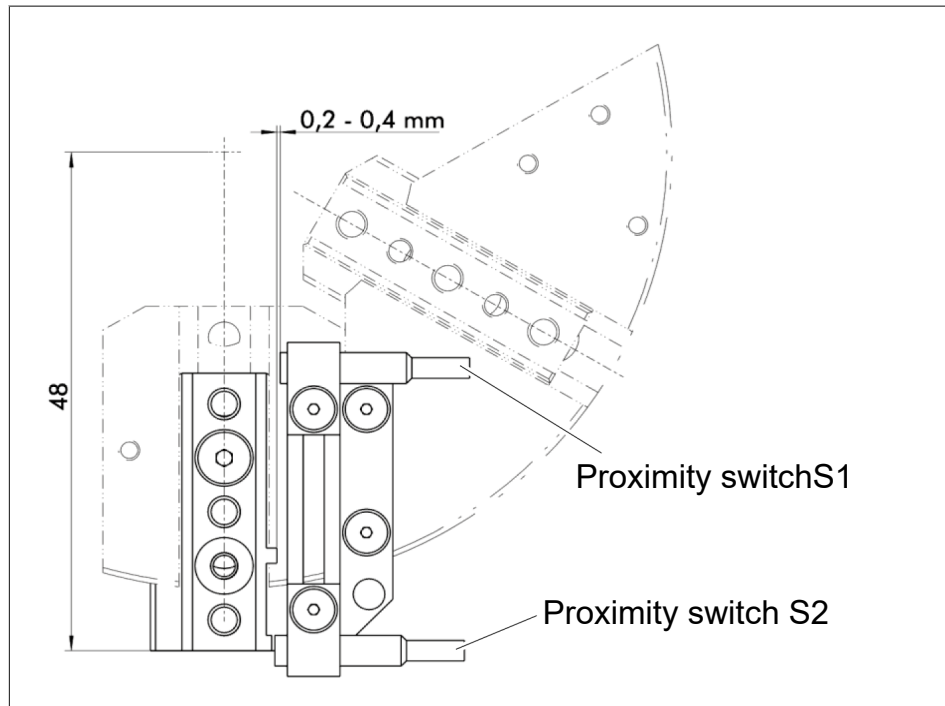

Step 5 Setting the proximity switches

- The position of the proximity switch S2 on the holding plate (21) can no longer be adjusted radially outwards. In order to monitor further "Gripper OPEN" positions, the proximity switch S2 must now be set in such a way that it is damped by cam 1 (1 mm high) like proximity switch S1.

Step 6 (Example: Gripper approx. 21 mm "OPEN", bracket rotated 180°)

1. Proximity switch S1 is not damped.
2. Proximity switch S2 is damped by cam 1 (1 mm high).

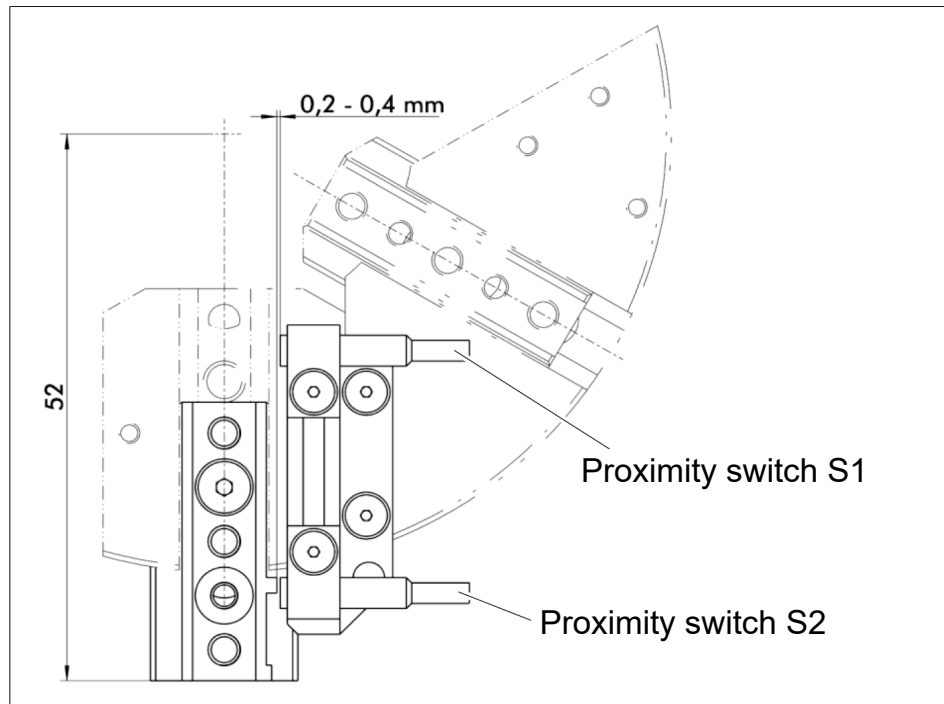

Step 6 Setting the proximity switches

3. After setting the proximity switches, attach the top jaws to the intermediate jaws (23). The position of the top jaws on the intermediate jaws (23) can be adjusted by previously measured distances A and B!

4.6.4 Mounting the sensor cables

- Snap the connector on the sensor cable into the NHS cable bracket (24) to secure the cable, ▶ 4.6.3 [34].

5 Function and handling

5.1 Pneumatic circuit diagram

The O-ring gripper is driven by three drive units:

1. Triple jaw A (double-action)
2. Triple jaw B (single-action)
3. Z-stroke (single-action)

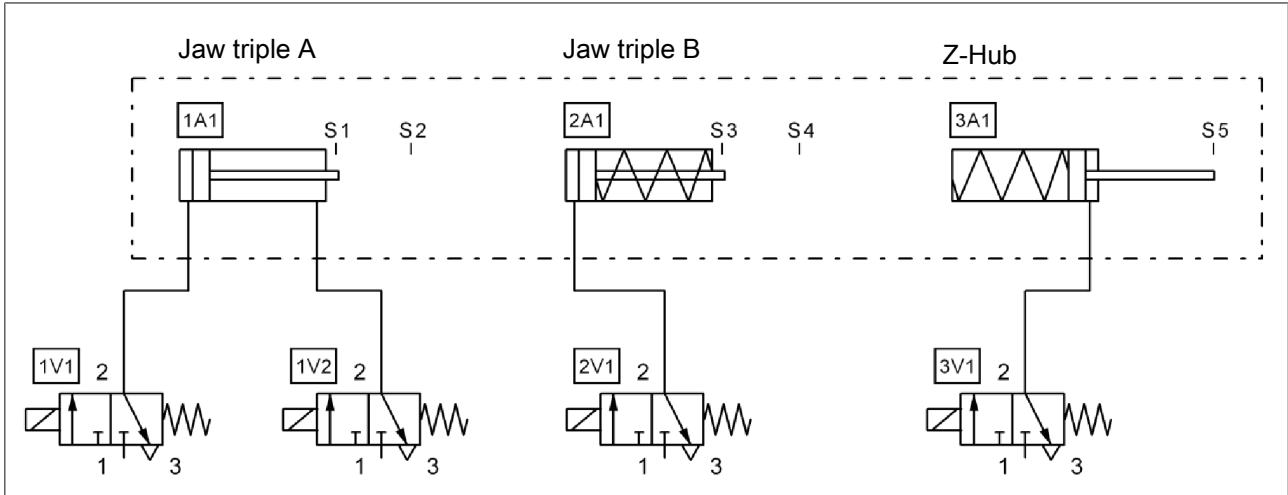

Pneumatic circuit diagram for ORG with four 3/2-way valves

The use of four 3/2-way valves is recommended to operate the gripper.

NOTE

Alternatively to four 3/2-way valves, one 5/3-way valve with vented centre position can be used for triple jaw A and one 3/2-way valve each for triple jaw B and the Z-stroke.

THAT IS: 4 x 3/2 or 1 x 5/3 + 2 x 3/2

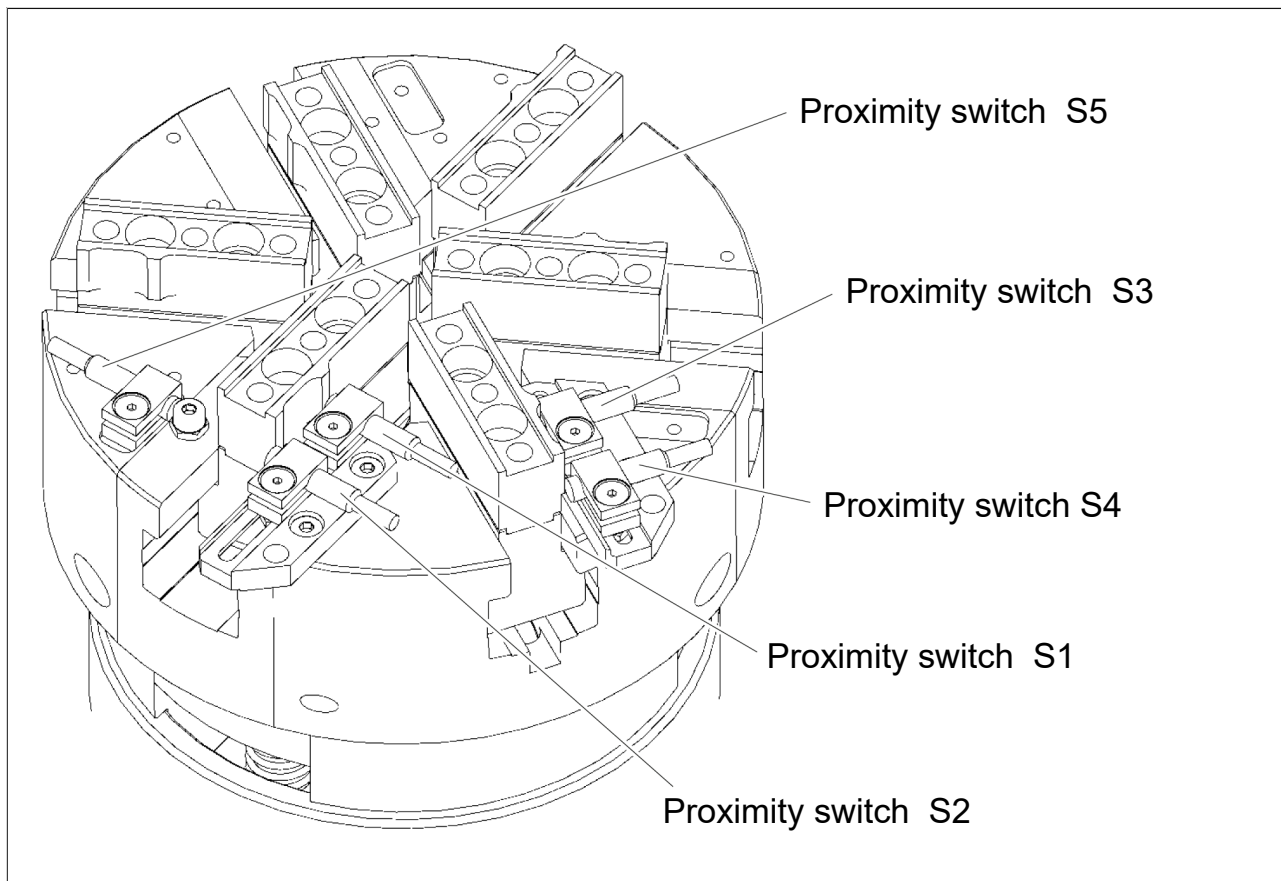

Overview of proximity switches on the gripper

The proximity switches S1 and S2 are dampened by the drive unit triple jaw A, whereby proximity switch S1 only scans the "CLOSED" position and proximity switch S2 only scans the "OPEN" position. The proximity switches S3 and S4 are dampened by drive unit triple jaw B, whereby proximity switch S3 only monitors the "CLOSED" position and proximity switch S4 only scans the "OPEN" position.

Proximity switch S5 is dampened by the drive unit Z-stroke, whereby proximity switch S5 is only dampened when the Z-stroke is up / forward.

5.2 Function diagram external assembly

The following figure shows the conditions and condition changes of the 0-ring gripper for external assembly as a chart. The function diagram uses four 3/2-way valves in the same way as in the pneumatics circuit diagram on page 21. ▶ 5.1 [42]

Please note the additional information and comments on the function diagram and the assembly procedure below the function diagram!

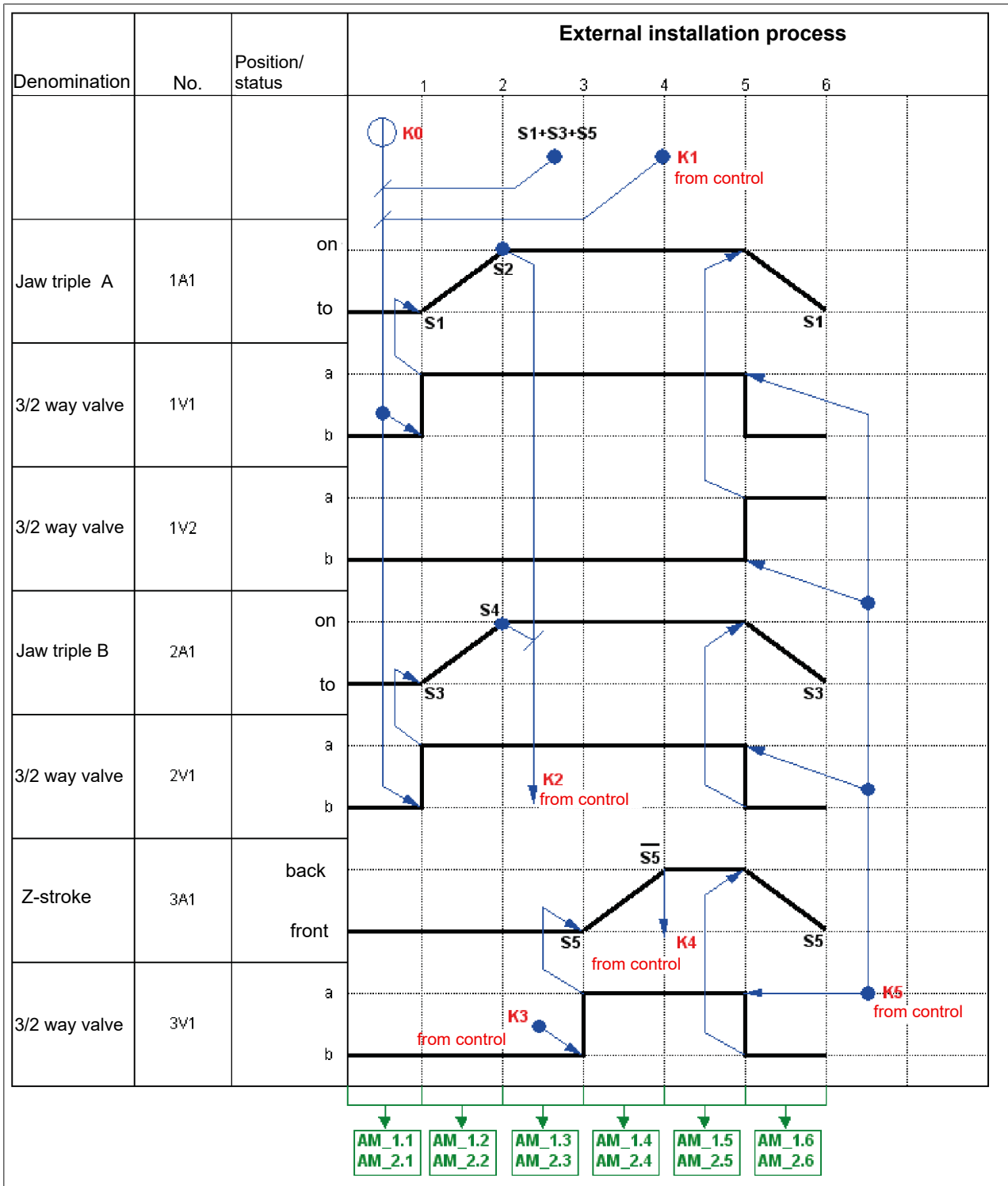

Function diagram external assembly

Notes on the external assembly function diagram:

It must be noted:

To ensure the correct control sequences of the 0-ring gripper during external assembly, it is necessary, among other things, that various signals are returned by or for the control. In the function diagram, they are highlighted in red by "K0 to K5".

Basic or starting position of the gripper during external assembly:

Triple jaw A and triple jaw B closed and Z-stroke at the front ▶ 5.3.1 [47].

Process step external assembly AM_1.1

The 0-ring gripper has been positioned at the transfer point. The control sends back the signal K1 "grripper arrived at transfer point". Since triple jaw A and triple jaw B are closed and the Z-stroke is forward, proximity switches S1, S3 and S5 are dampened.

The next process step can be started together with the signals S1, S3, S5, K1 and K0 "start the assembly procedure".

Process step external assembly AM_1.2 ▶ 5.3.2 [48]

The 0-ring gripper continues to be positioned at the transfer point. Triple jaw A and triple jaw B open up. Proximity switches S2 and S4 are now dampened.

The control will now send back the signal K2 "Move gripper to assembly position".

Process step external assembly AM_1.3 ▶ 5.3.3 [49]

The 0-ring gripper is moved to the shaft and positioned at the groove level. The control sends back the signal K3 "Assembly position has been reached". Triple jaw A and triple jaw B are still in "condition open". The proximity switches S2 and S4 continue to be dampened.

The next process step can be started together with the signals S2, S4 and K3 "assembly position has been reached".

Process step external assembly AM_1.4 ▶ 5.3.4 [50]

The 0-ring gripper continues to be positioned at the assembly position. The Z-stroke moves to the back. The proximity switch S5 is no longer dampened. The next process step can be started since proximity switch S5 is no longer dampened.

The control now receives back the signal K4 "move gripper to position above the shaft end".

Process step external assembly AM_1.5 ▶ 5.3.5 [51]

The 0-ring gripper is moved from the assembly position to a position above the shaft end.

When this position has been reached, the control sends back the signal K5 "grripper above shaft end".

The next process step can be started.

Process step external assembly AM_1.6 ▶ 5.3.6 [51]

Triple jaw A and triple jaw B move to "CLOSED" and the Z-stroke moves to the front again. The external assembly procedure is completed and a new cycle can follow.

NOTE

The external assembly procedure AM_2.1 to AM_2.6 runs analogous to the external assembly procedure AM_1.1 to AM_1.6!

5.3 Details of external assembly procedure, Range of inside seal diameter between $d_1=10$ mm and $d_1=60$ mm

Position of the item numbers ▶ 4.2.2 [20]

5.3.1 External assembly AM_1.1

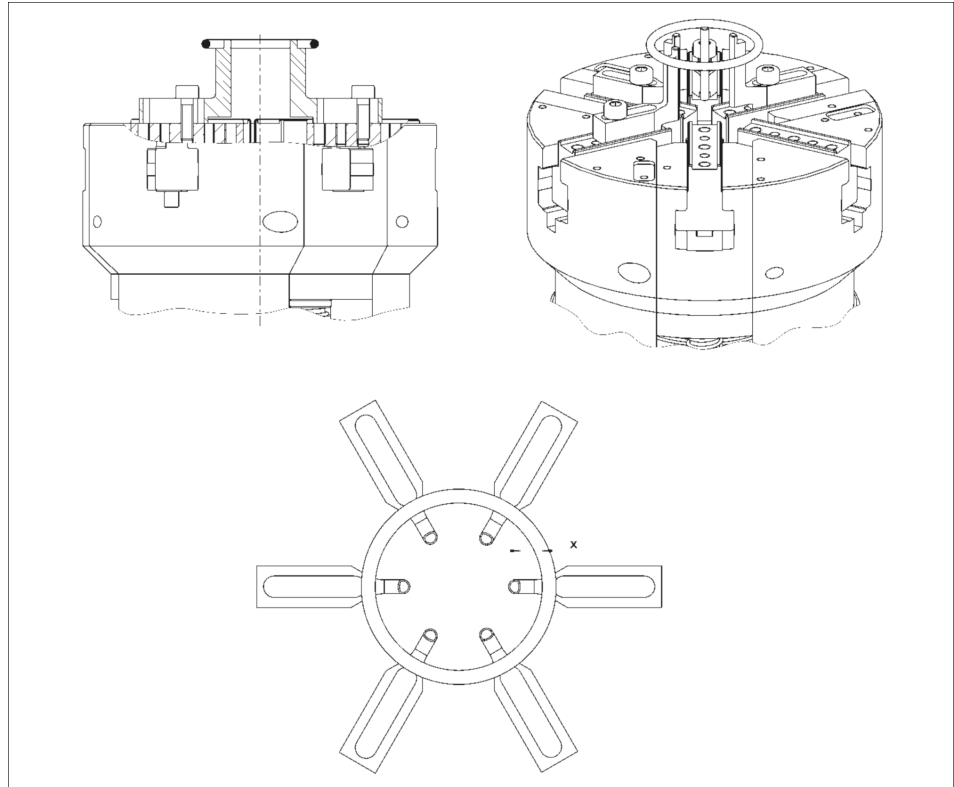

External assembly AM_1.1, Range of inside seal diameter between $d_1=10$ mm and $d_1=60$ mm

The six assembly fingers must be adjusted so that they are in the gripper condition "CLOSED" within the seal and aligned centrally towards the centre axis of the gripper. Depending on the ovality of the seal, there must be a sufficient safety distance (dimension x) between the seal and the assembly fingers.

NOTE

It must be checked whether the stroke of triple jaw A and triple jaw B are set so that the assembly fingers of the gripper do not overstretch the seal in the opened condition! **THEREFORE: When starting up, open up the assembly fingers of the gripper without the seal to set the top jaws! (compressed air connection (3) and (4) pressurised) Then, before proceeding with external assembly AM_1.2, adjust the jaw stroke to the seal size to be assembled in accordance with chapter „Setting the end positions“ ▶ 4.5 [29]!**

5.3.2 External assembly AM_1.2

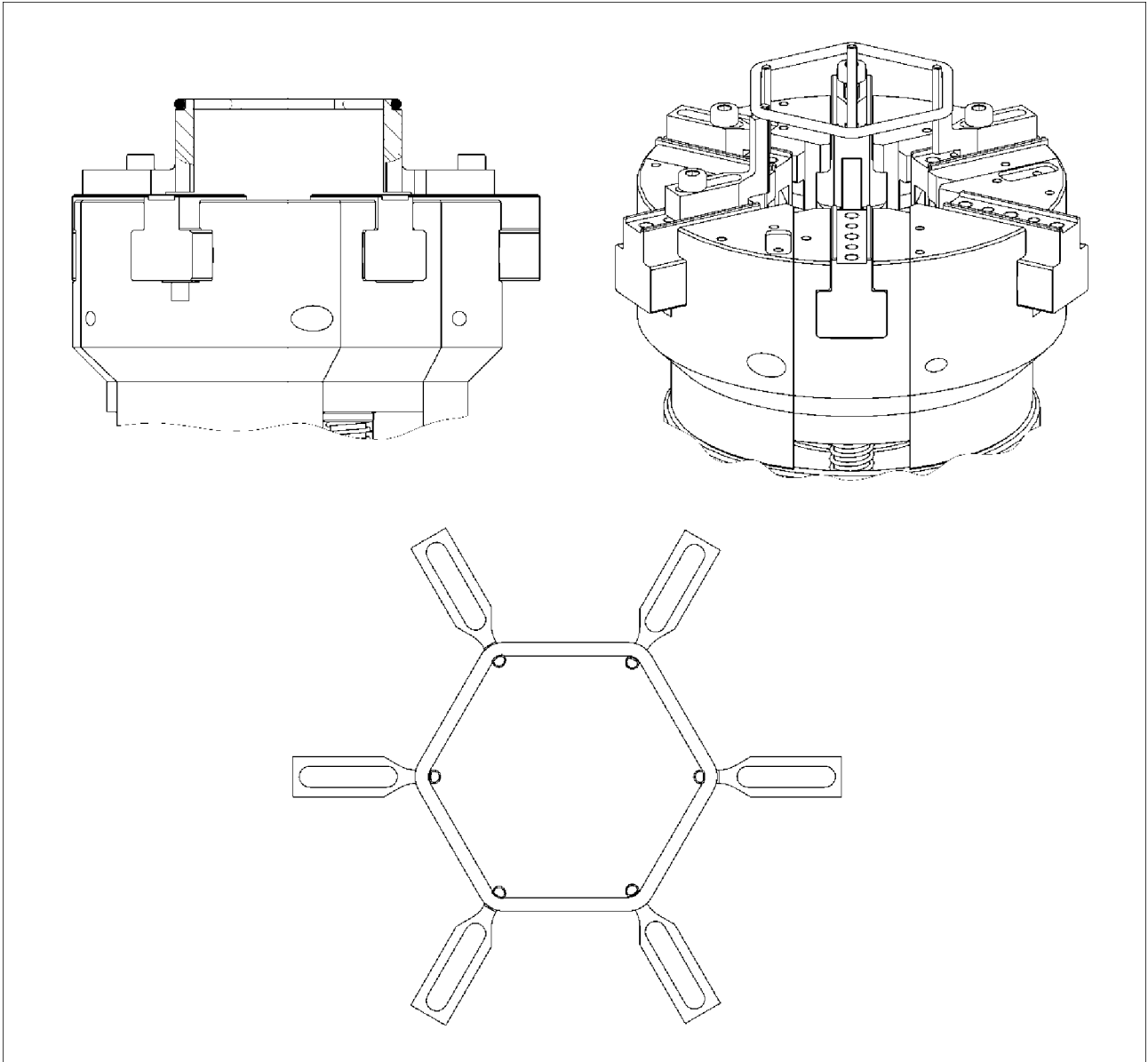

External assembly AM_1.2, Range of inside seal diameter between $d_1=10$ mm and $d_1=60$ mm

The gripper fingers of the gripper can be opened (compressed air connections (3) and (4) pressurised). The seal is widened into the shape of a hexagon.

5.3.3 External assembly AM_1.3

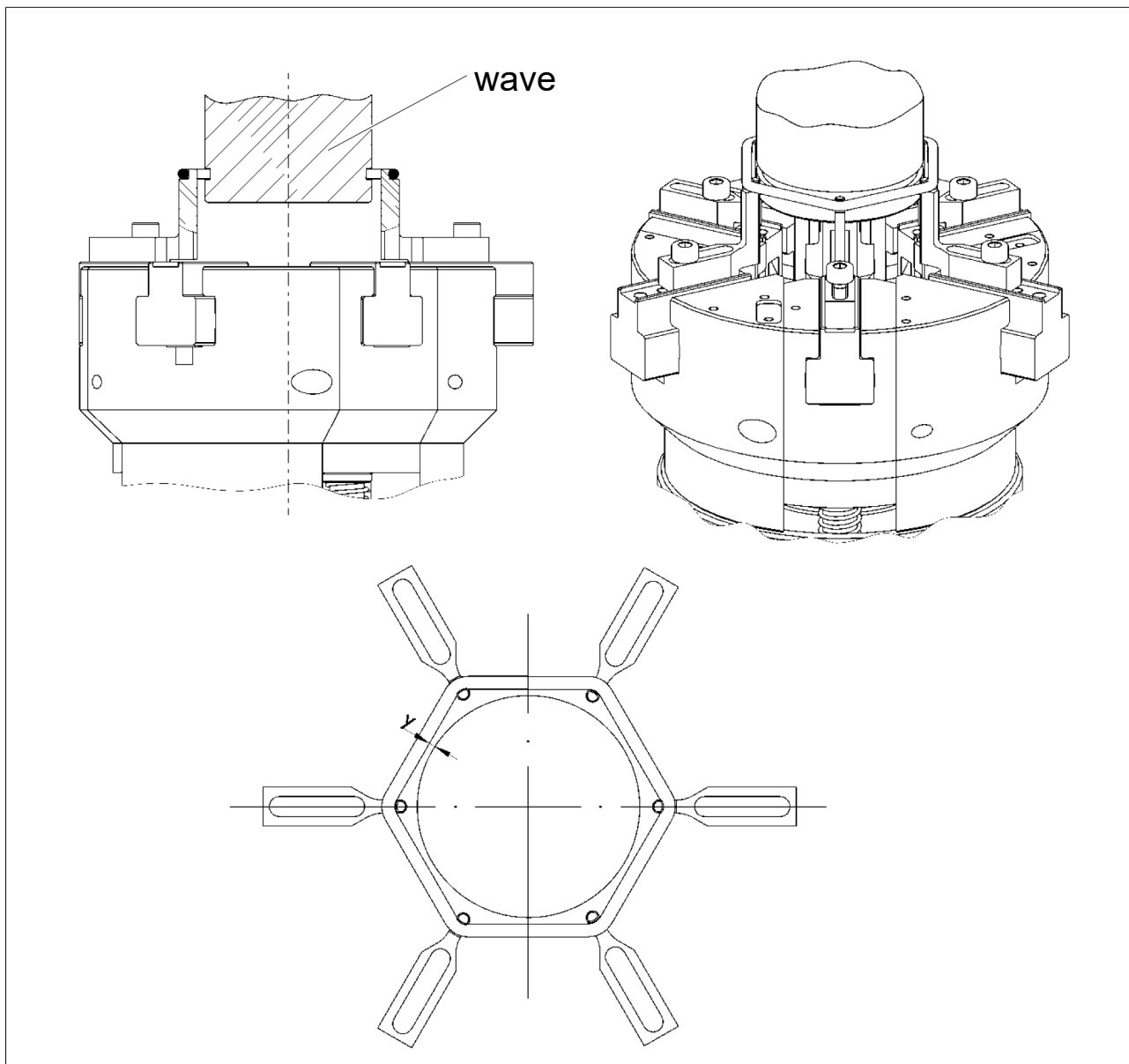

External assembly AM_1.3, Range of inside seal diameter between $d_1=10$ mm and $d_1=60$ mm

In the "OPEN" gripper condition, the seal must be widened sufficiently so that a distance larger than zero (dimension y) is created between the widened seal (shape of a hexagon) and the shaft.

With the widened seal, the gripper can then be positioned at the position / level of the seal groove of the shaft.

NOTE

Dimension y should be as small as possible to ensure a reliable assembly cycle and to prevent overextension of the seal!

The centre axis of the gripper and the shaft must be aligned concentrically!

5.3.4 External assembly AM_1.4

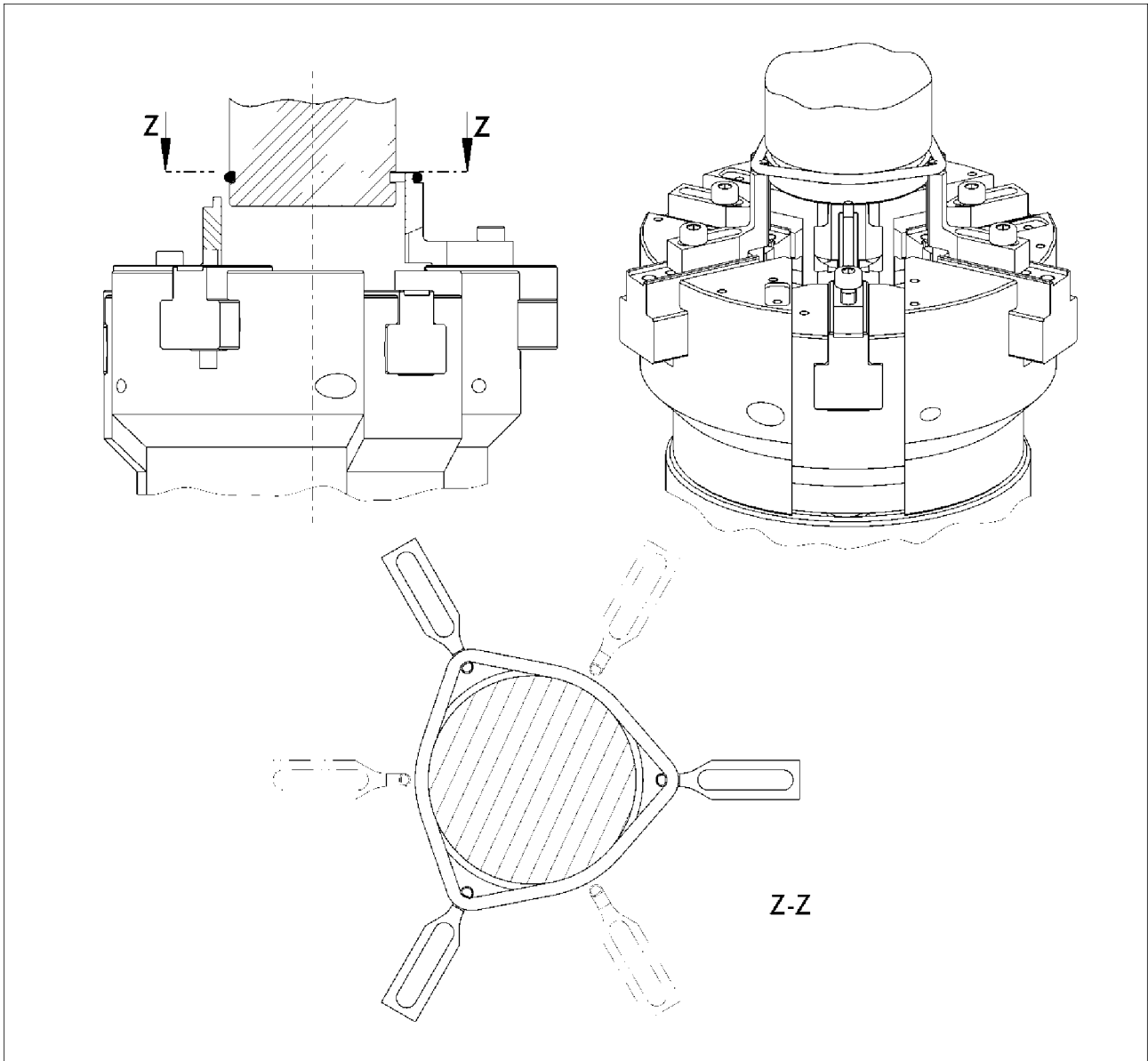

External assembly AM_1.4, Range of inside seal diameter between $d_1=10$ mm and $d_1=60$ mm

After the seal picked up by the gripper was moved to the position / level of the seal groove of the shaft, the Z-stroke of triple jaw A is pulled back in the the next step, pressurise compressed air connection (2) ▶ 4.2.2 [20].

The seal is now positioned at three points in the groove of the shaft.

5.3.5 External assembly AM_1.5

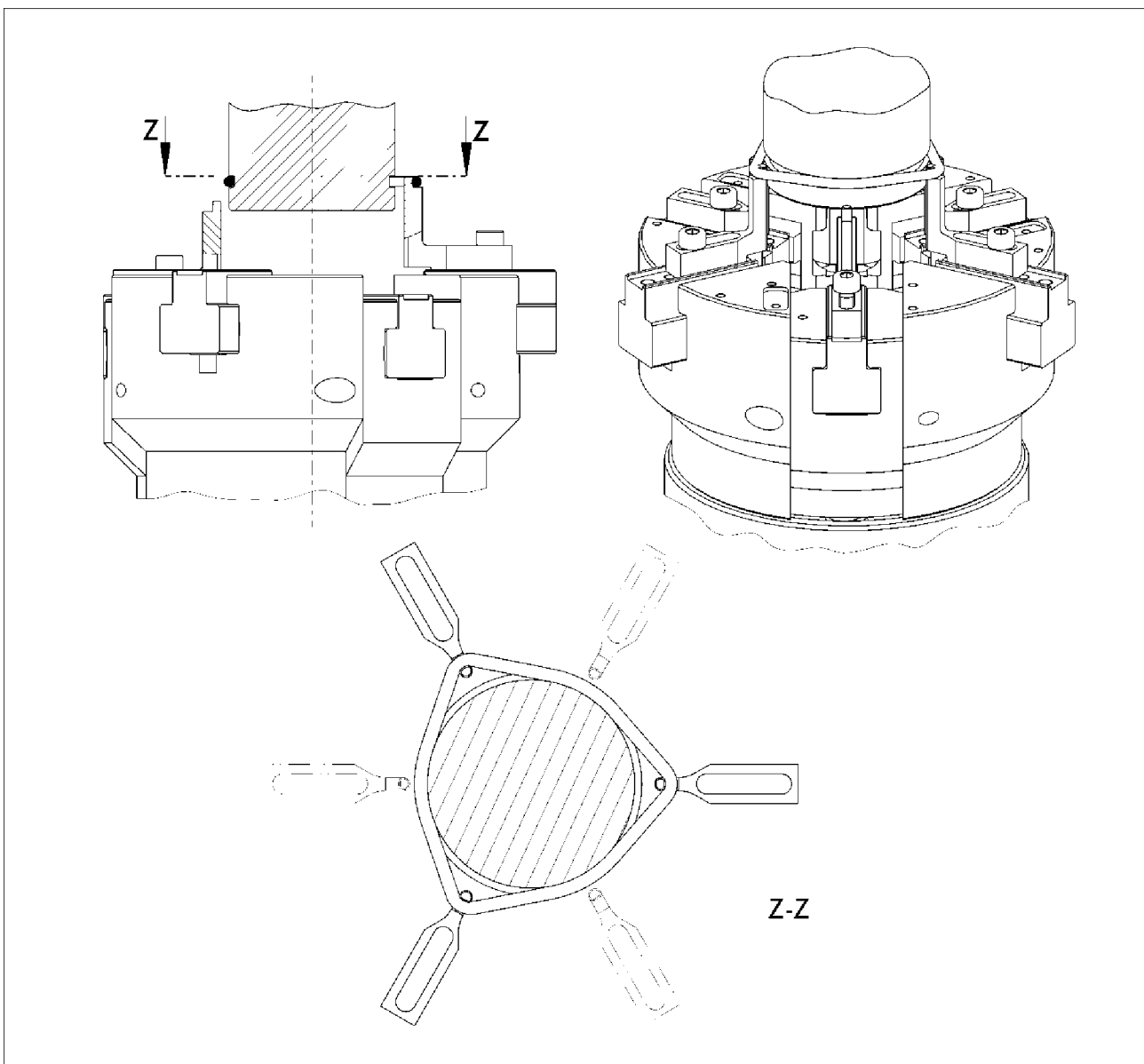

External assembly AM_1.5, Range of inside seal diameter between $d_1=10$ mm and $d_2=60$ mm

The entire gripper is now moved backward in axial direction, whereby the seal is stripped off the three assembly fingers of the triple jaw B and slides completely into the groove. The assembly cycle has been completed.

5.3.6 External assembly AM_1.6

For another assembly cycle, move the triple jaws A and B as well as the Z-stroke into the start-ing position. Close triple jaws A and B as well as Z-stroke toward the front. Compressed air connection (1) pressurised, compressed air connections (4) and (2) not pressurised ▶ 4.2.2 [20].

5.4 Details of external assembly procedure, Range of inside seal diameter between $d_1 > 60$ mm and approx. $d_1 = 150$ mm

Position of the item numbers ▶ 4.2.2 [□ 20]

5.4.1 External assembly AM_2.1

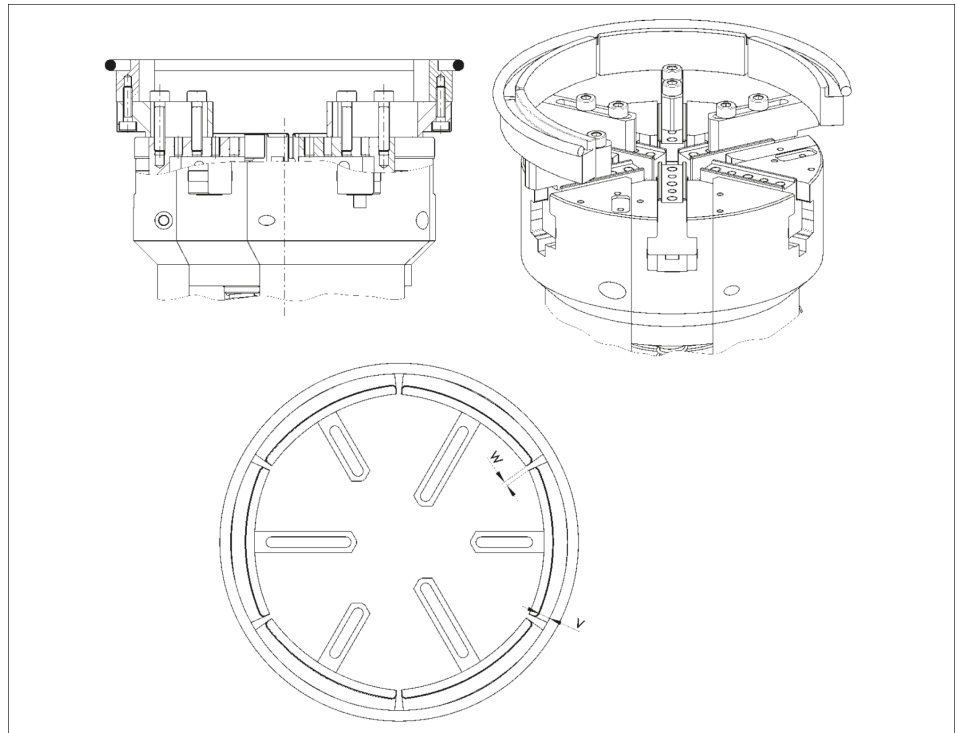

External assembly AM_2.1, Range of inside seal diameter between $d_1 > 60$ mm and approx. $d_1 = 150$ mm

The top jaws must be adjusted so that they are inside the non-widened seal in the "CLOSED" gripper condition. Depending on the ovality of the seal, there must be a sufficient safety distance at the transfer point (dimension v) between the seal and the top jaws.

Moreover, the segment jaws must not collide in the "CLOSED" gripper condition, i.e. a second safety distance (dimension w) must be observed between the segment jaws.

NOTE

It must be checked whether the stroke of triple jaw A and triple jaw B is adjusted so that the top jaws of the gripper do not overstretch the seal in the opened condition!

- Open up the top jaws of the gripper without the seal! (compressed air connections (3) and (4) pressurised ▶ 4.2.2 [□ 20]). Then, before proceeding with the external assembly AM_2.2, adjust the jaw stroke to the seal size to be assembled in accordance with chapter „Setting the end positions“ ▶ 4.5 [□ 29]!
-

5.4.2 External assembly AM_2.2

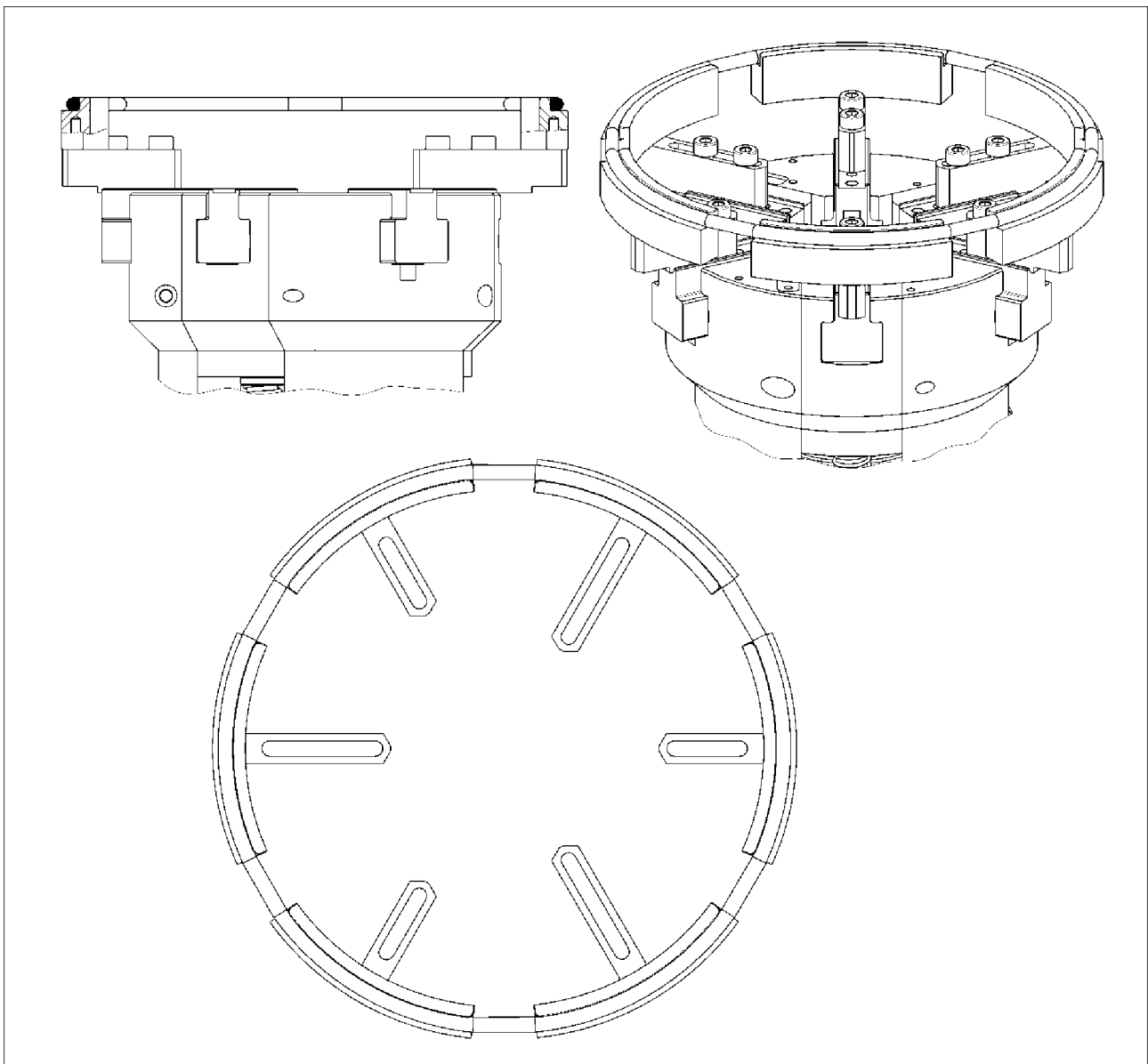

External assembly AM_2.2, Range of inside seal diameter between $d_1 > 60$ mm and approx. $d_1 = 150$ mm

The triple jaws of the gripper can be opened (compressed air connections (3) and (4) pressurised). The seal is widened by means of the segment jaws.

5.4.3 External assembly AM_2.3

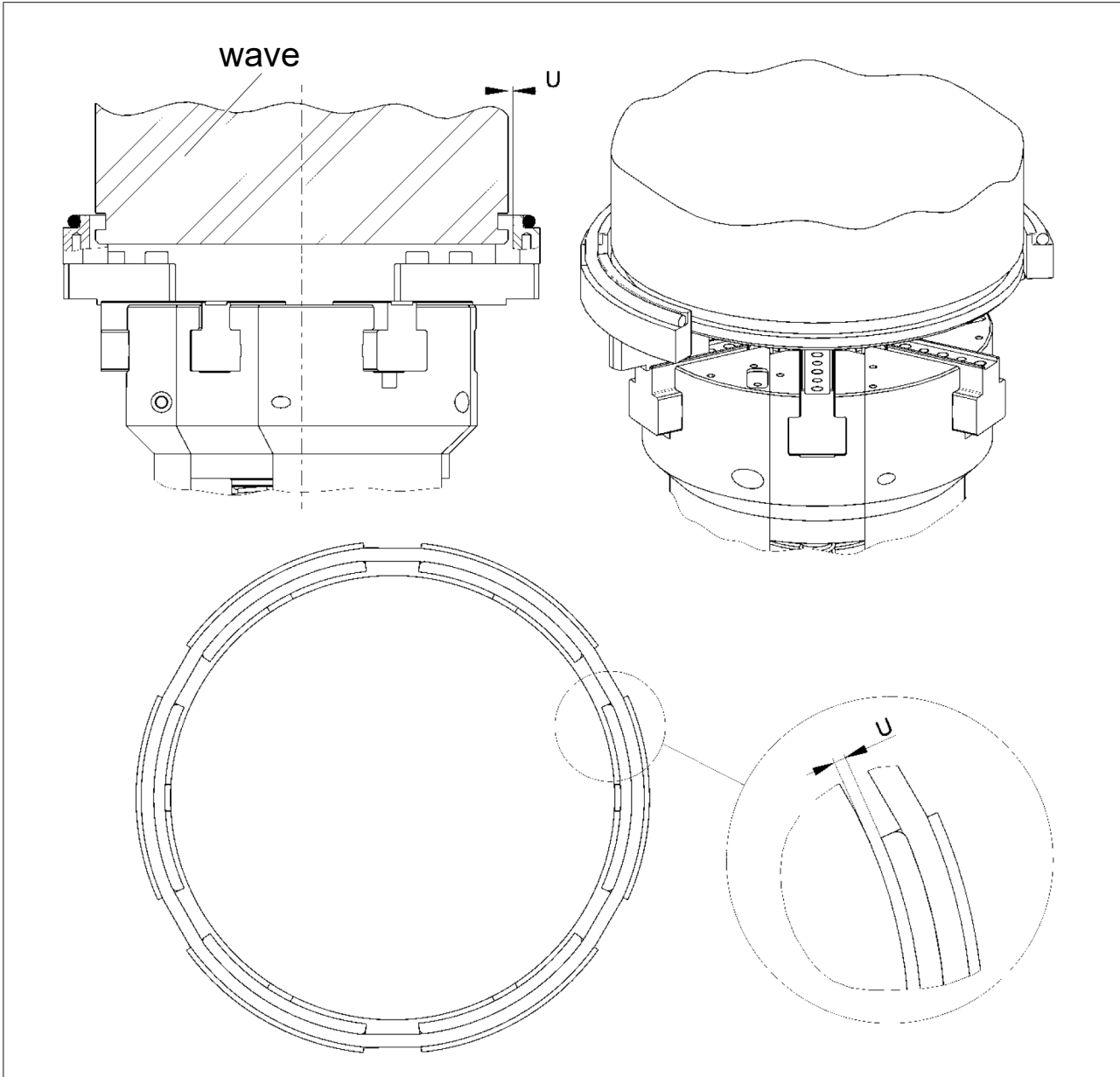

External assembly AM_2.3, Range of inside seal diameter between $d_i > 60$ mm and approx. $d_i = 150$ mm

In the "OPEN" gripper condition, the seal must be widened sufficiently so that a distance larger than zero (dimension u) is created between the segment jaws and the shaft.

With the widened seal, the gripper can then be positioned at the position / level of the seal groove of the shaft.

NOTE

With the widened seal, the gripper can then be moved to or positioned at the position / level of the seal groove of the shaft.

5.4.4 External assembly AM_2.4

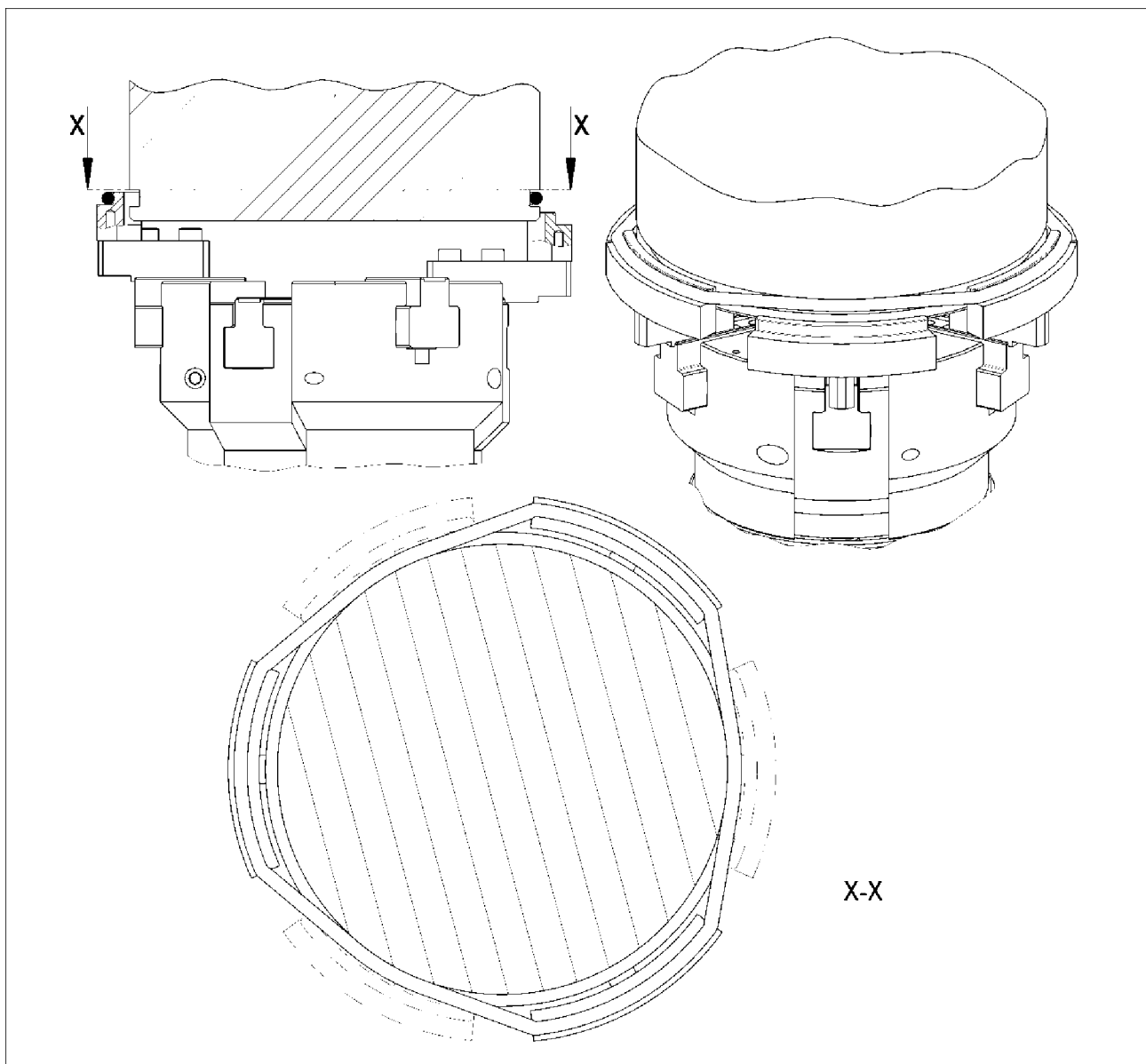

External assembly AM_2.4, Range of inside seal diameter between $d_1 > 60$ mm and approx. $d_1 = 150$ mm

After the gripper has been moved to the position / level of the seal groove of the shaft, the Z-stroke of triple jaw A is pulled back axially in the next step (pressurise compressed air connection (2)).

The seal is now positioned at three points in the groove of the shaft.

5.4.5 External assembly AM_2.5

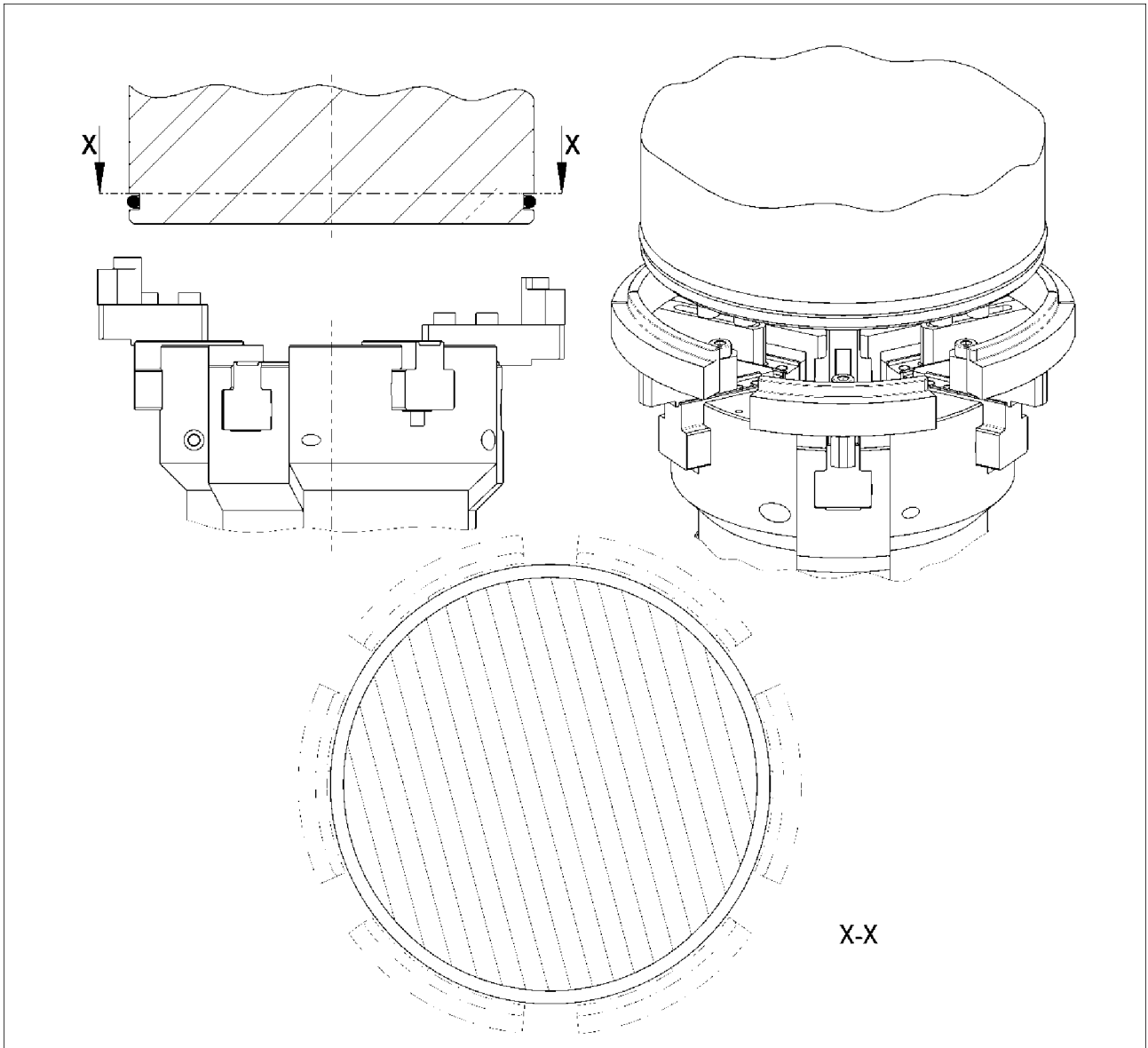

External assembly AM_2.5, Range of inside seal diameter between $d_i > 60$ mm and approx. $d_i = 150$ mm

The entire gripper is now moved backward in axial direction, whereby the seal is stripped off the three assembly fingers of the triple jaw B and slides completely into the groove. The assembly cycle has been completed.

The entire gripper is now moved backward in axial direction, whereby the seal is stripped off the three assembly fingers of the triple jaw B and slides completely into the groove. The assembly cycle has been completed.

5.4.6 External assembly AM_2.6

For another assembly cycle, move the triple jaws A and B as well as the Z-stroke into the start-ing position. Close triple jaws A and B as well as Z-stroke toward the front. Compressed air connection (1) pressurised, compressed air connections (4) and (2) not pressurised ▶ [4.2.2 \[20\]](#).

5.5 Function diagram internal assembly

The following figure shows the conditions and condition changes of the 0-ring gripper for internal assembly as a chart. The function diagram uses four 3/2-way valves in the same way as in the pneumatics circuit diagram ▶ 5.1 [42].

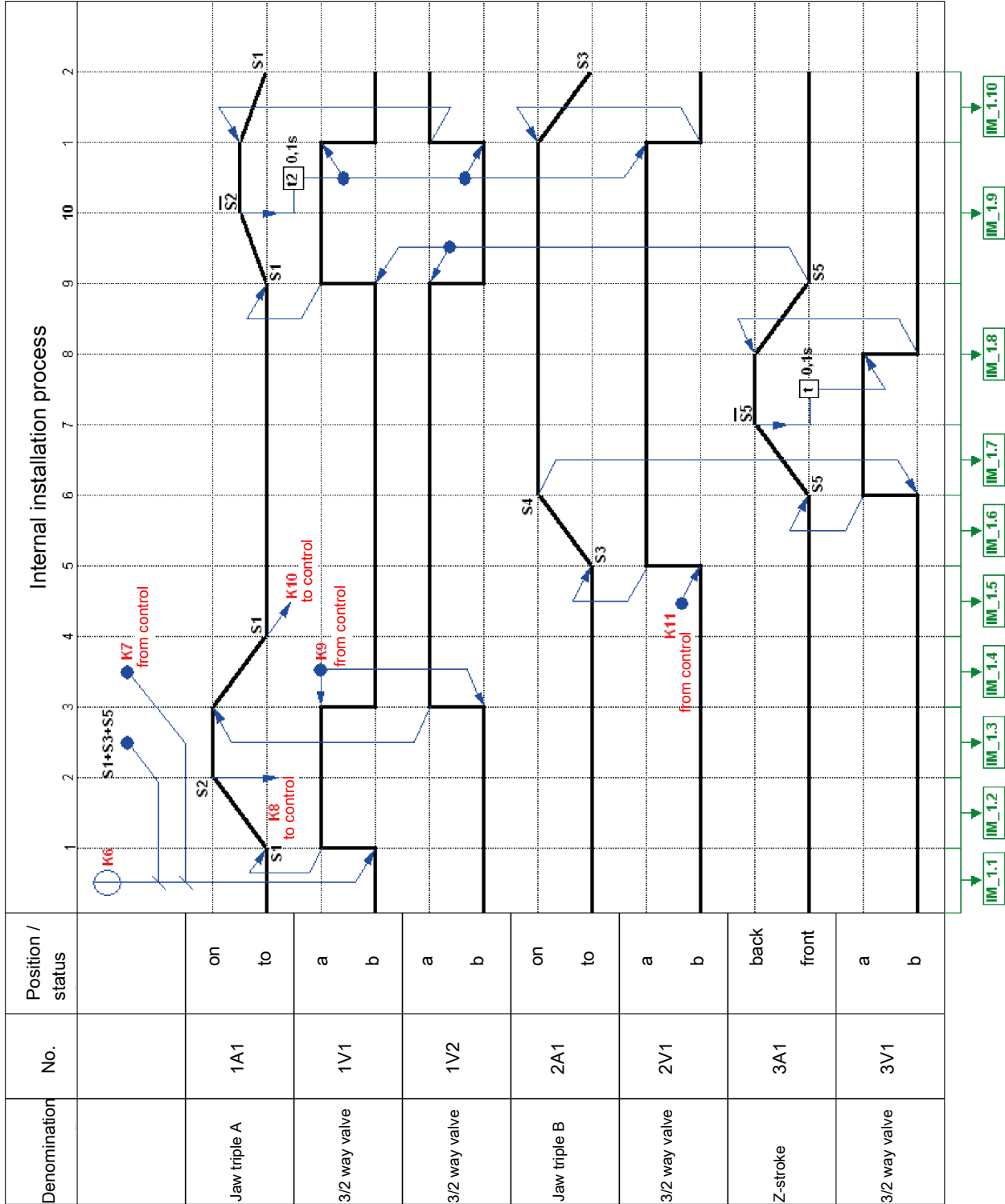

Function diagram internal assembly

Notes on the function diagram internal assembly:

Basic or starting position of the gripper during internal assembly:

Process step internal assembly

IM_1.1 ▶ 5.6.1 [61]

Process step internal assembly

IM_1.2 ▶ 5.6.2 [62]

Process step internal assembly

IM_1.3 ▶ 5.6.3 [62]

Process step internal assembly

IM_1.4 ▶ 5.6.4 [64]

Process step internal assembly

IM_1.5 ▶ 5.6.5 [67]

Process step internal assembly

IM_1.6 ▶ 5.6.6 [68]

Process step internal assembly

IM_1.7 ▶ 5.6.7 [70]

It must be noted:

To ensure the correct control sequences of the 0-ring gripper during internal assembly, it is necessary, among other things, that various signals are returned by or for the control. In the function diagram, they are highlighted in red by "K6 to K11".

Triple jaw A and triple jaw B closed. The Z-stroke is forward.

The 0-ring gripper was positioned on a position above the seal at the transfer point. The control sends back the signal K7 "grripper arrived at transfer point above the seal".

Since triple jaw A and triple jaw B are closed and the Z-stroke is forward, proximity switches S1, S3 and S5 are dampened (basic position).

The next process step can be started together with the signals S1, S3, S5, K7 and K6 "start the assembly procedure".

The 0-ring gripper is still at the position above the seal at the transfer point. The triple jaw A opens. Triple jaw B remains closed and the Z-stroke remains forward. Proximity switch S2 is now dampened by the opening of triple jaw A. The control is now sent back the signal K8 "moving 0-ring gripper axially back down to the transfer point".

The 0-ring gripper is positioned at the transfer point to pick up the seal. Triple jaw A is open. Triple jaw B remains closed. The Z-stroke remains forward. The control sends back the signal K9 "grripper positioned on transfer point".

The 0-ring gripper remains at the transfer point position to pick up the seal. Triple jaw A is being closed. Triple jaw B remains closed. The Z-stroke remains forward. Proximity switch S1 is now dampened again by closing triple jaw A. The control is sent back the signal K10 "moving 0-ring gripper to assembly position".

The 0-ring gripper is positioned at the assembly position to assemble the seal. Triple jaw A and triple jaw B remain closed. The Z-stroke remains forward. The control sends back the signal K11 "grripper positioned in assembly position".

The 0-ring gripper remains at the assembly position to assemble the seal. Triple jaw A remains closed. Triple jaw B opens. The Z-stroke remains forward. Proximity switch S4 is dampened by opening triple jaw B.

The 0-ring gripper remains at the assembly position to assemble the seal. Triple jaw A remains closed. Triple jaw B remains open. The Z-stroke is pulled axially to the back.

By moving back the Z-stroke, proximity switch S5 switch is no longer dampened.

Process step internal assembly

IM_1.8 ▶ 5.6.8 [71]

The O-ring gripper remains at the assembly position to assemble the seal. Triple jaw A remains closed. Triple jaw B remains open.

The Z-stroke remains at the back for 0.1 seconds (time relay). After 0.1 seconds have lapsed, the Z-stroke is moved forward again.

Proximity switch S5 is dampened again by moving the Z-stroke forward.

Process step internal assembly

IM_1.9 ▶ 5.6.9 [72]

The O-ring gripper remains at the assembly position to assemble the seal. The triple jaw A opens. Triple jaw B remains open. The Z-stroke remains forward. Sensor S2 is not dampened since triple jaw A moves against the wall of the bore and does not open completely.

That is why a time relay of 0.1 seconds must be used in this case. This means that triple jaw A opens and remains in the "OPEN" position for 0.1 seconds.

Process step internal assembly

IM_1.10 ▶ 5.6.10 [73]

The O-ring gripper remains at the assembly position to assemble the seal. Triple jaw A and triple jaw B move together after 0.1 seconds (IM_9). The Z-stroke remains forward.

Proximity switches S1 and S3 are dampened again by closing triples jaws A and B.

The internal assembly procedure is completed and a new cycle can follow.

5.6 Details of internal assembly procedure

Position of the item numbers ▶ 4.2.2 [20]

5.6.1 Internal assembly IM_1.1

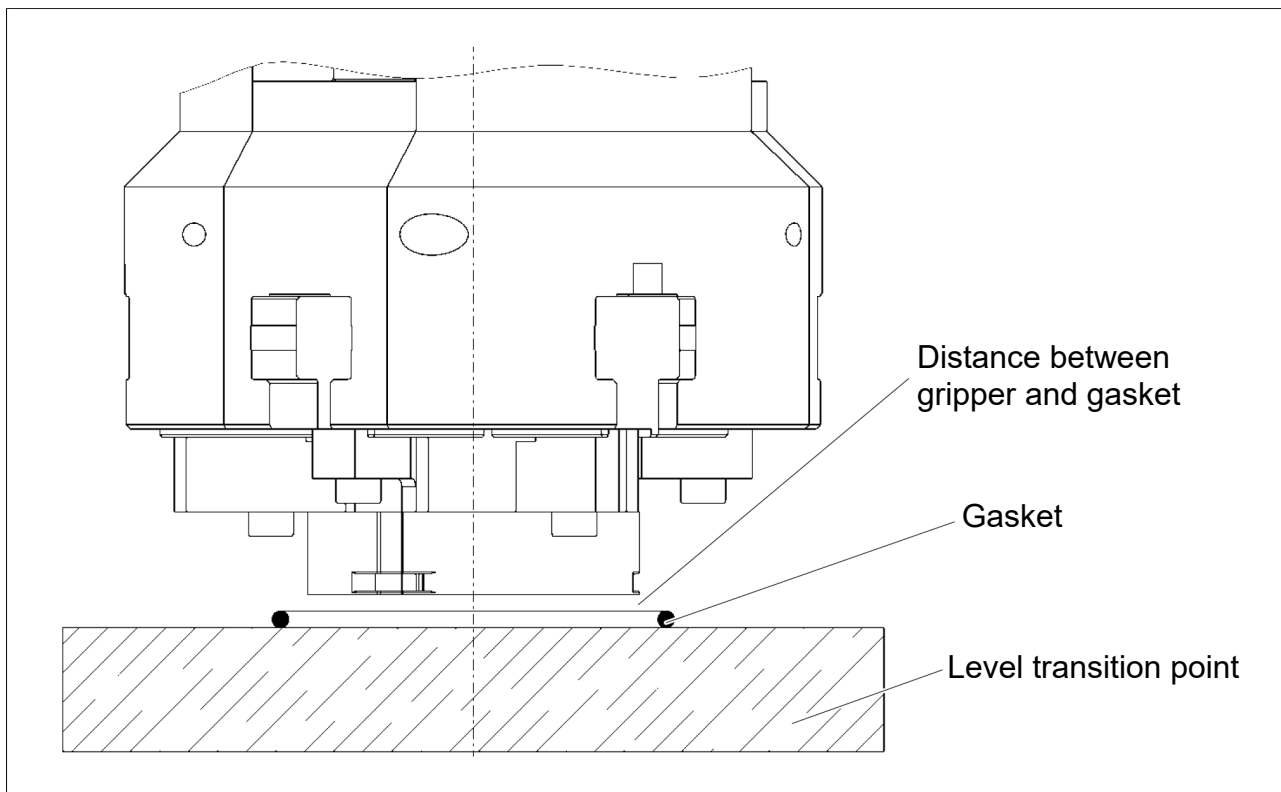

Internal assembly IM_1.1

Triple jaw A and triple jaw B closed. The Z-stroke is forward.
In the first step, the O-ring gripper must be positioned above the seal (the precondition is that the seal is picked up on a level).

5.6.2 Internal assembly IM_1.2

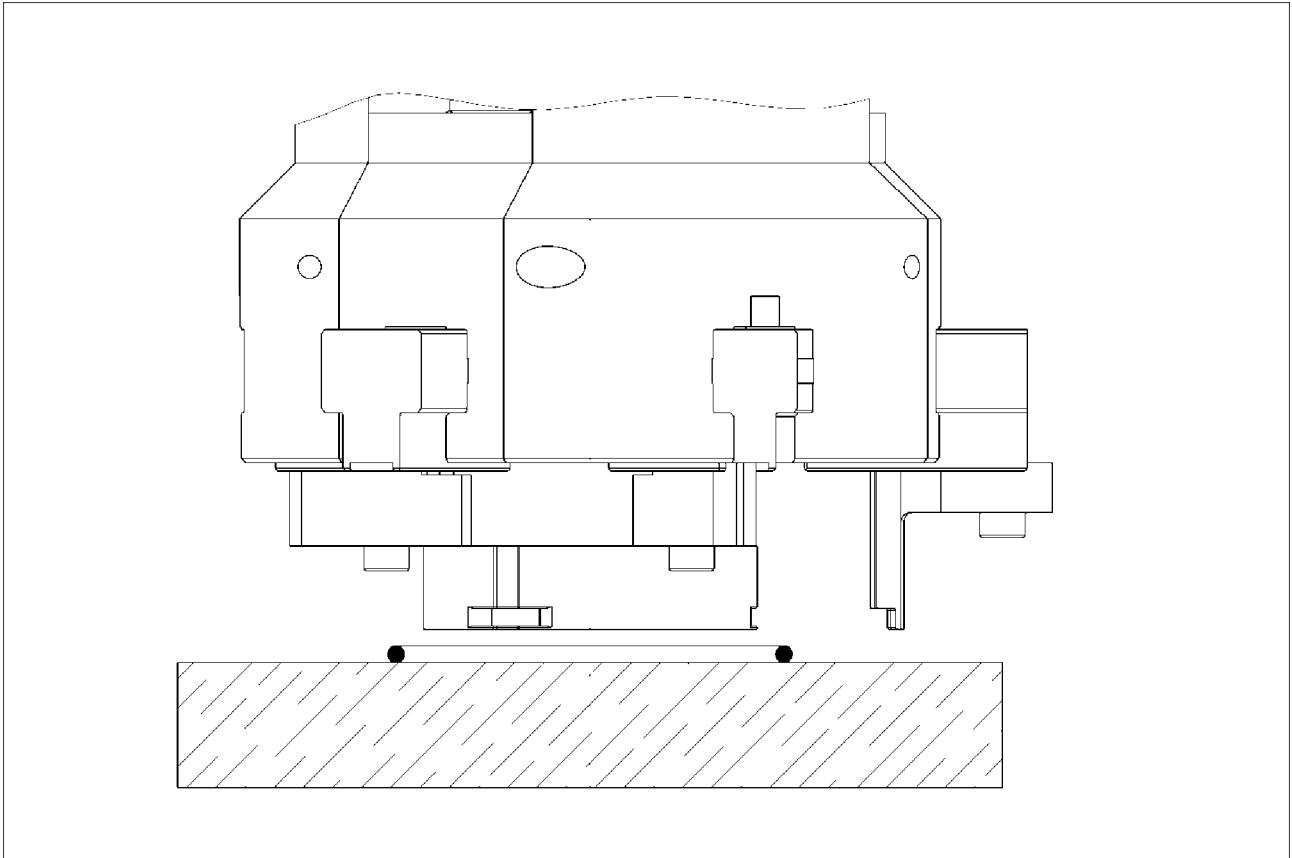

Internal assembly IM_1.2

The triple jaw A opens. Triple jaw B remains closed and the Z-stroke remains forward.

5.6.3 Internal assembly IM_1.3

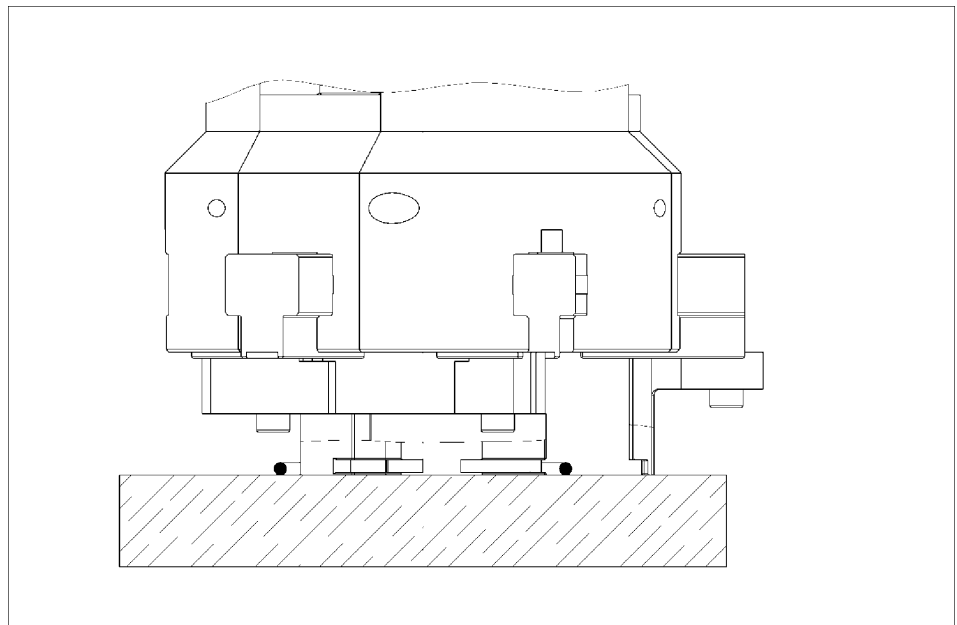

Internal assembly IM_1.3 Figure with transfer point

5.6.4 Internal assembly IM_1.4

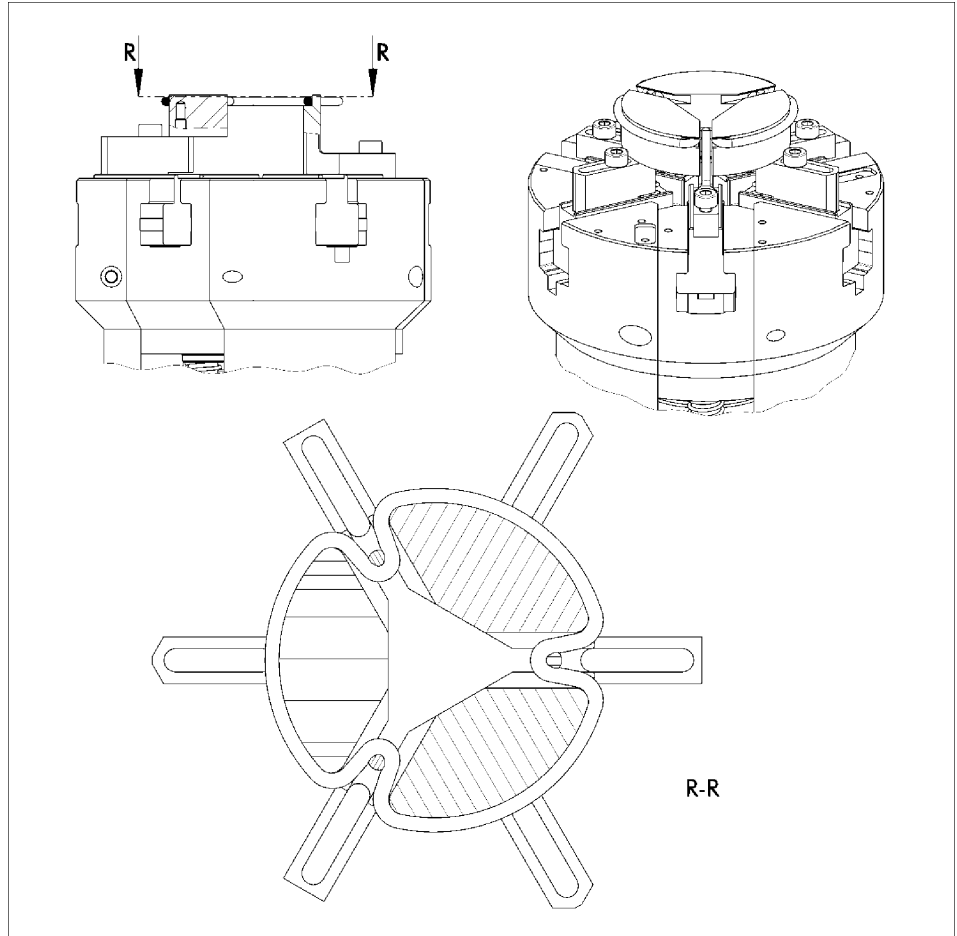

Internal assembly IM_1.4

Triple jaw A can be closed. The gripper fingers move radially toward the inside between the segment jaws and mould the seal locally between the segment jaws.

The following figures show how the seal should not be redirected.

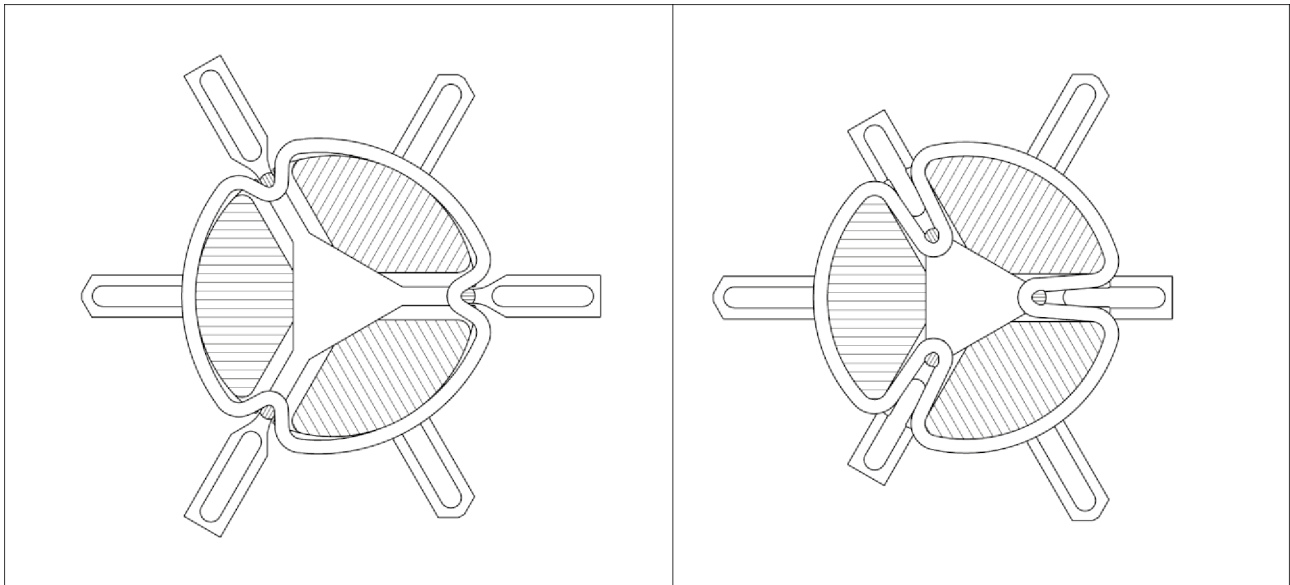

Left: Internal assembly: Faulty redirection; Right: Internal assembly: Faulty redirection

Tab.: Internal assembly: Faulty redirection

Left figure	Right figure
The seal does not rest properly against the segment jaws!	The gripper fingers have moved too far toward the gripper centre!
The seal can collide with the workpiece when entering the bore!	The seal is locally overextended!
The gripper fingers have not moved far enough toward the gripper centre!	

By moulding the seal between the segment jaws, the assembly fingers and the segment jaws can enter the bore of the workpiece with the moulded seal.

The following figure shows what the redirection of the seal must look like.

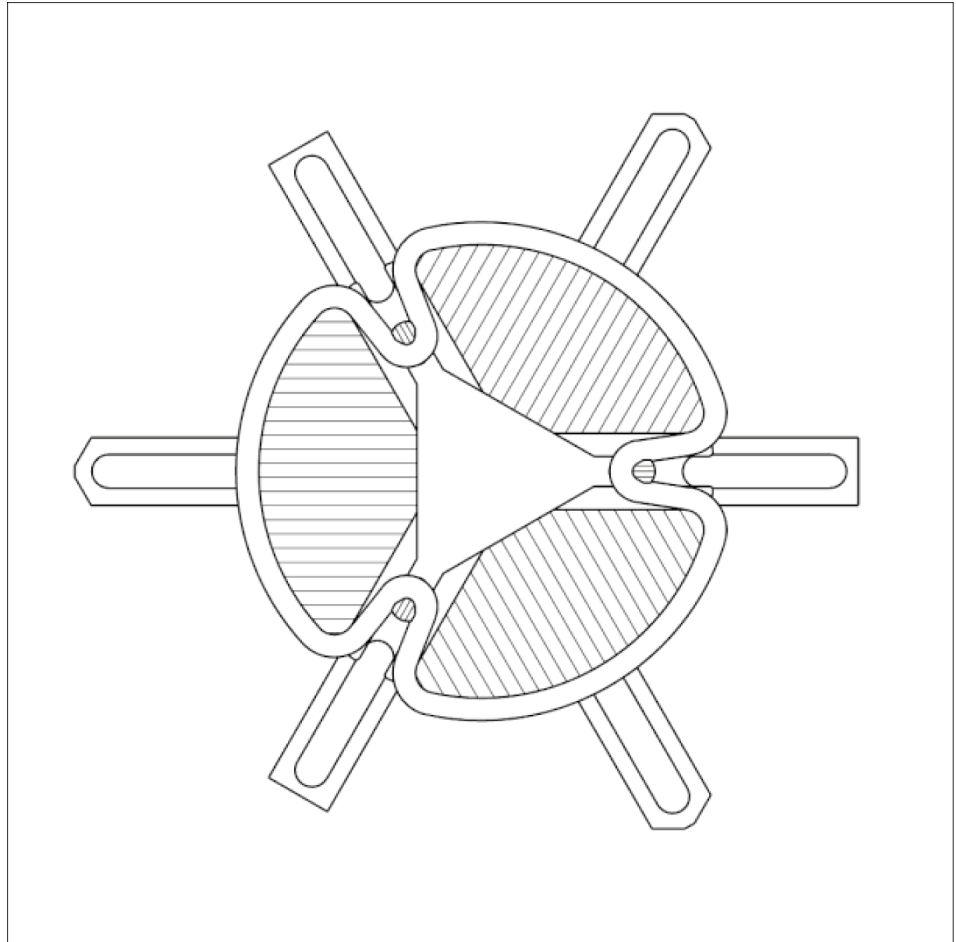

Internal assembly: Correct redirection

When the triple jaw A is closed, the gripper fingers must have been moved far enough to the inside so that:

- 1.** the seal properly encloses the segment jaws,
- 2.** the seal is only slightly extended around the gripper finger tips, i.e. it is not lengthened too much,
- 3.** the enclosing diameter of the redirected seal is smaller than the bore in the assembly workpiece.

5.6.5 Internal assembly IM_1.5

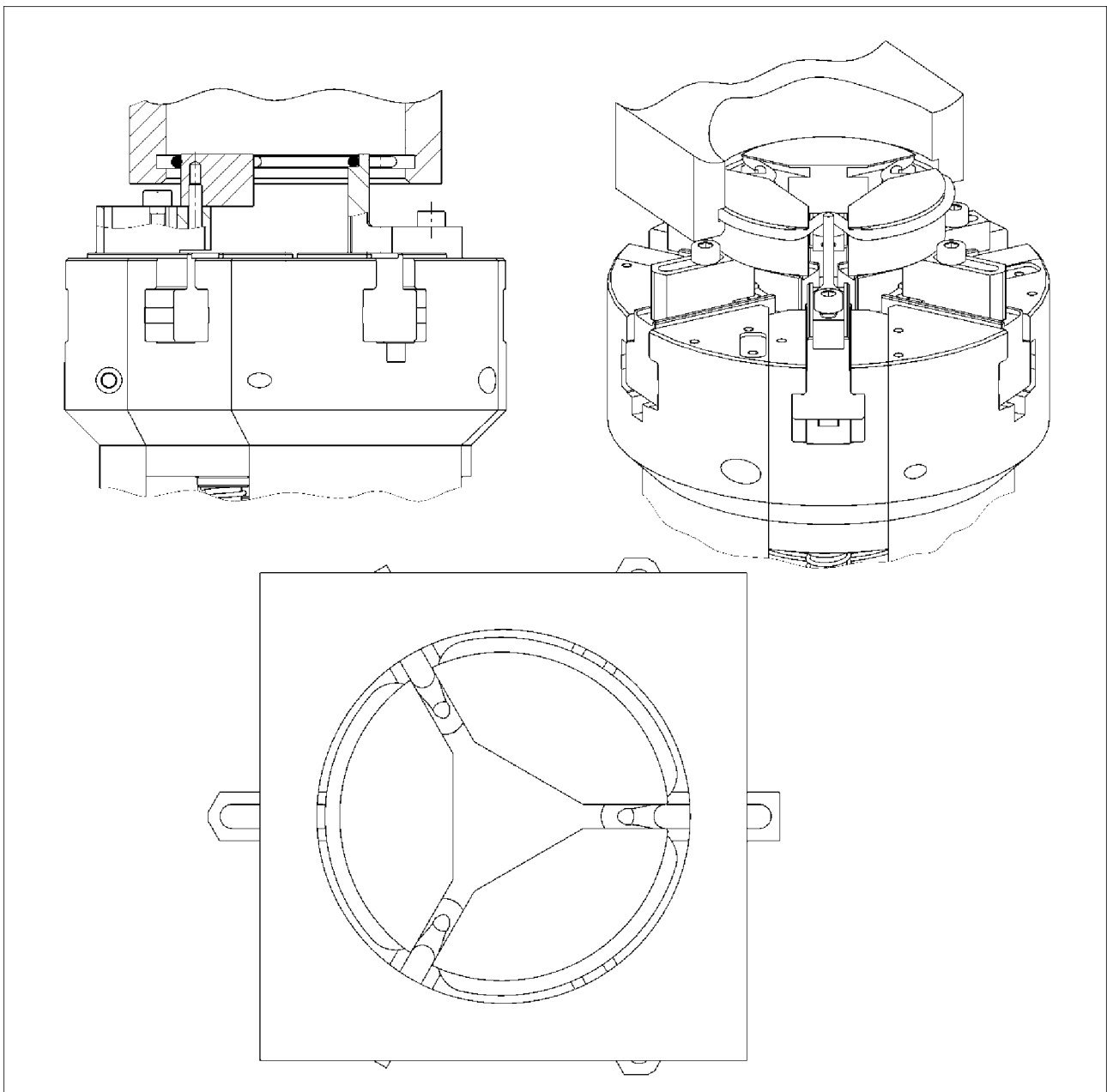

Internal assembly IM_1.5

The gripper can then be moved or positioned to the position / level of the seal groove of the bore. The centre axis of the gripper and the bore must be aligned concentrically!

5.6.6 Internal assembly IM_1.6

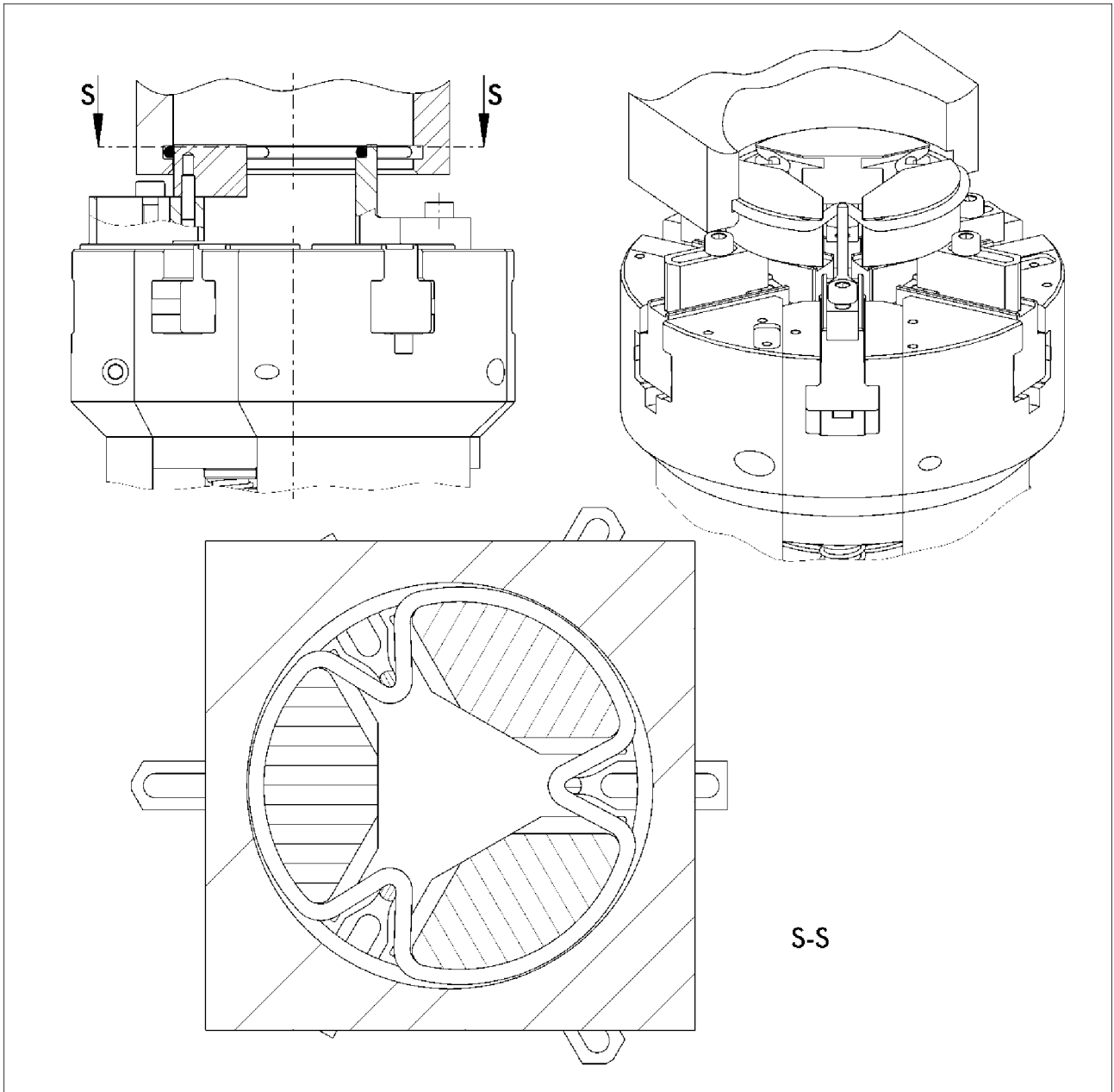

Internal assembly IM_1.6

After the gripper was moved to the position / level of the seal groove in the workpiece, triple jaw B can be opened. The following pointers must be observed before the triple jaw B can be opened.

NOTE

The stroke of the triple jaw B must be set as follows:
Description given under ► 4.5 [29].

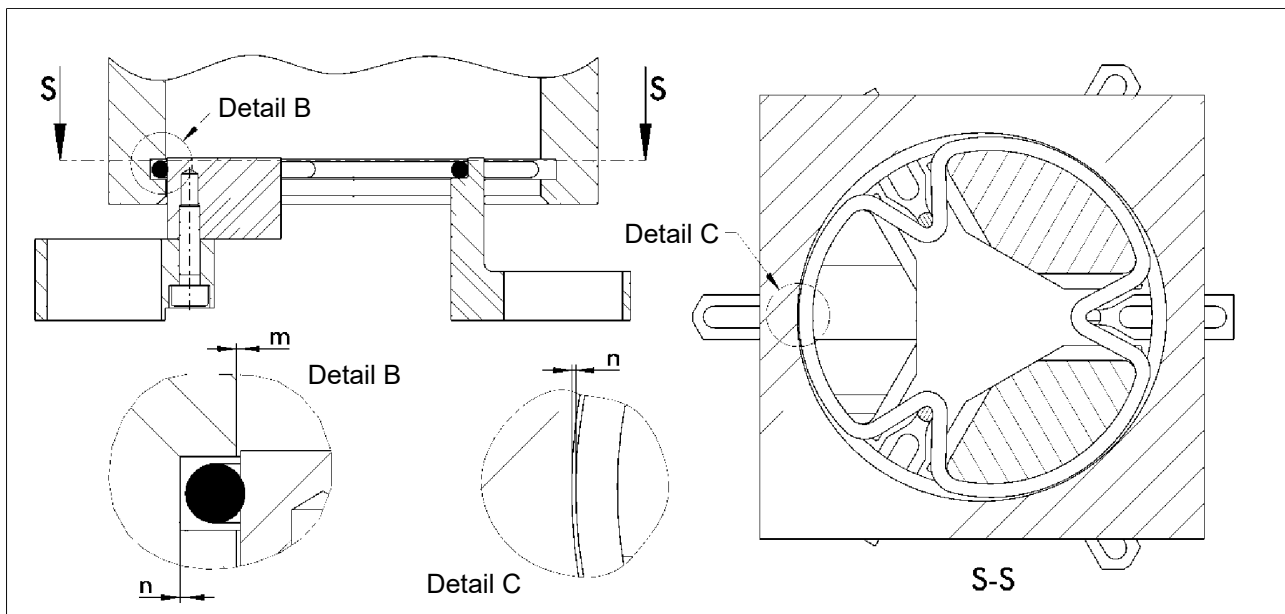

Setting triple jaw B stroke

Triple jaw B to which the segment jaws are attached may only open far enough to press the redirected seal into the groove of the bore. This stroke is usually about as large as the cord strength d_2 of the seal.

NOTE

The segment jaws must not move against the wall of the bore of the workpiece because this could lead to damage on the segment jaws and on the wall of the bore. A safety distance (dimension m) must be set between segment jaw and wall of the bore. Dimension m should thereby be as small as possible. In addition, a distance (dimension n) must be set between the base diameter of the groove and the redirected seal! It should also be as small as possible.

The easiest way to set the stroke of triple jaw B is to turn the workpiece on the centre axis of the bore as shown. If the workpiece cannot be turned, then the stroke of triple jaw B has been set too large, i.e. the seal is pressed against the groove of the base diameter. If the workpiece can be turned with a great deal of play, then the stroke of triple jaw B has been set too small, i.e. the redirected seal is not close enough to the base diameter of the groove (dimension n too large).

5.6.7 Internal assembly IM_1.7

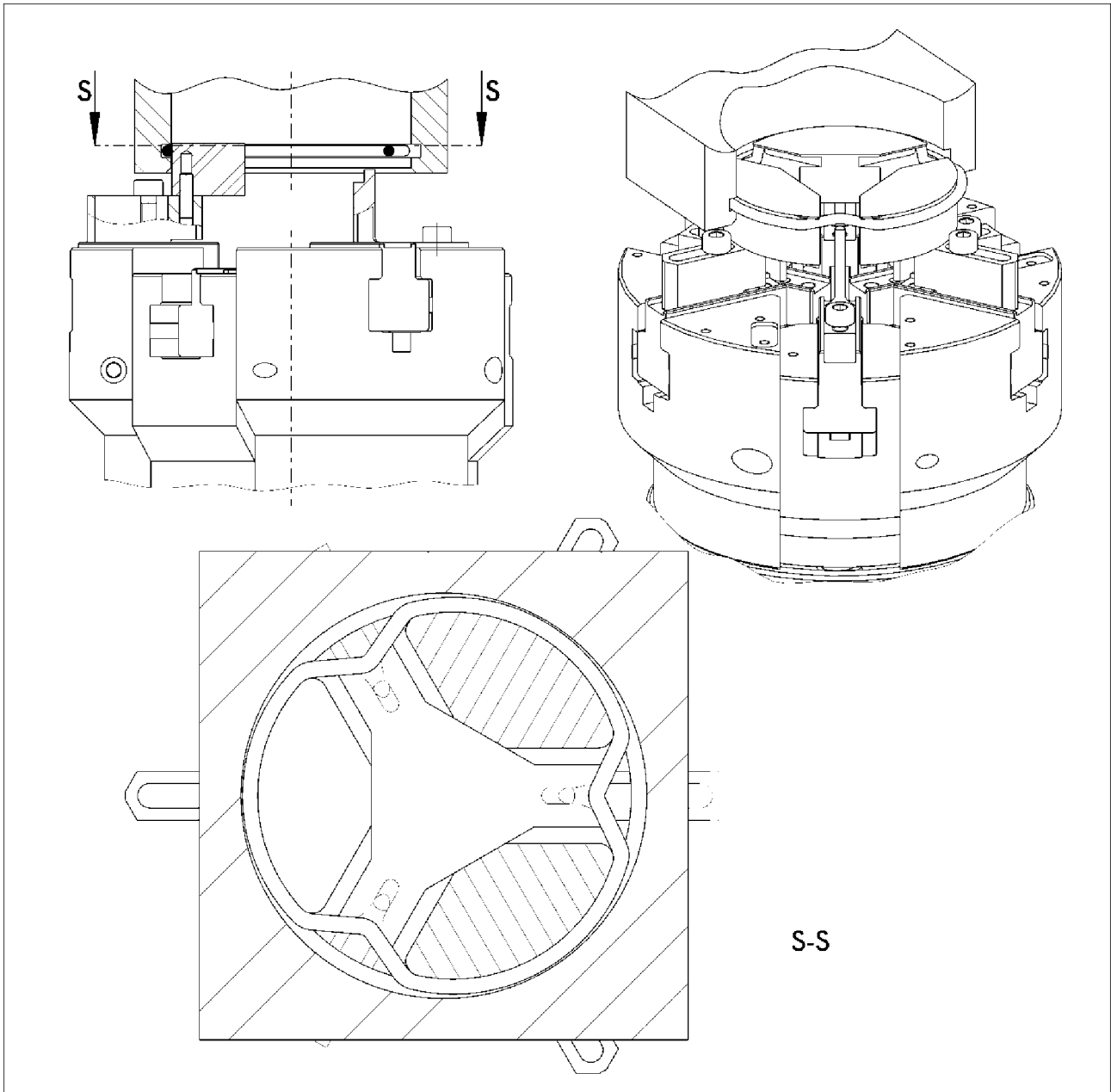

Internal assembly IM_1.7

The Z-stroke is axially pulled towards the back (pressurise compressed air connection (2)).

The gripper finger pulls axially toward the back and the seal relaxes slightly in the direction of the groove in the area of the assembly finger. The local relief of the seal between the segment jaws is absolutely essential to continue with the internal assembly IM_1.8 of the internal assembly procedure.

5.6.8 Internal assembly IM_1.8

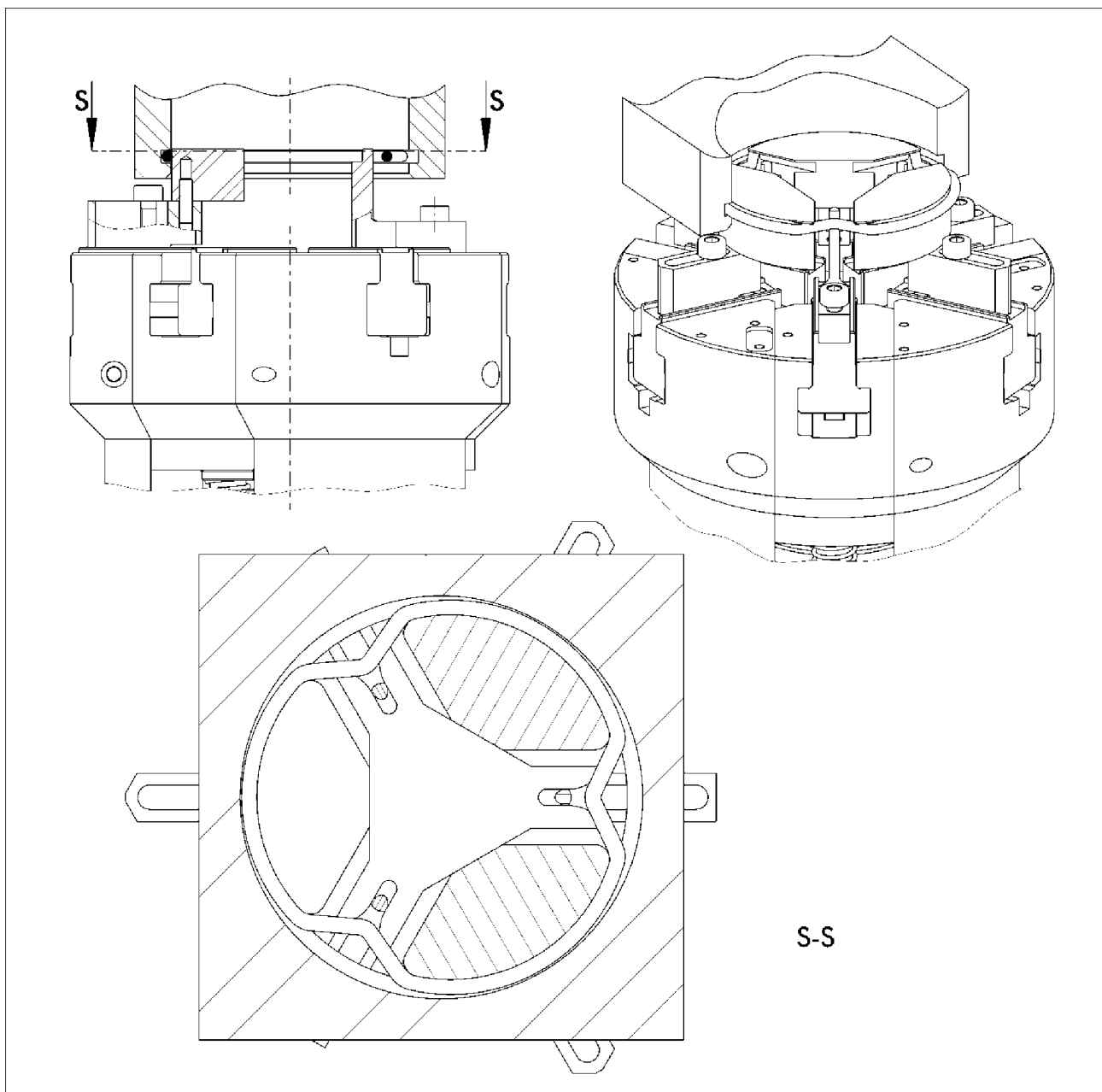

Internal assembly IM_1.8

After the axial pulling of the Z-stroke towards the back, the Z-stroke is directly moved forward again (do not pressurise compressed air connection (2)).

As shown in the figure, the three gripper fingers are now on the inside of the seal.

5.6.9 Internal assembly IM_1.9

NOTICE

Damage to the gripper fingers if the operating pressure is too high.

During internal assembly in the range from $d_1=10$ mm to $d_1=15$ mm, or when working with an assembly finger with a width of less than 2 mm, the operating pressure of triple jaw A must be reduced to max. 2.5 bar! If the operating pressure is not reduced, the assembly fingers could be damaged or destroyed.



⚠ WARNING

When working with gripper fingers with a longer overhang, the operating pressure of triple jaw A must always be adjusted! This reduced operating pressure depends on the individual version of the gripper fingers!

The assembly fingers radially open up toward the outside (compressed air connection (3) pressurised).

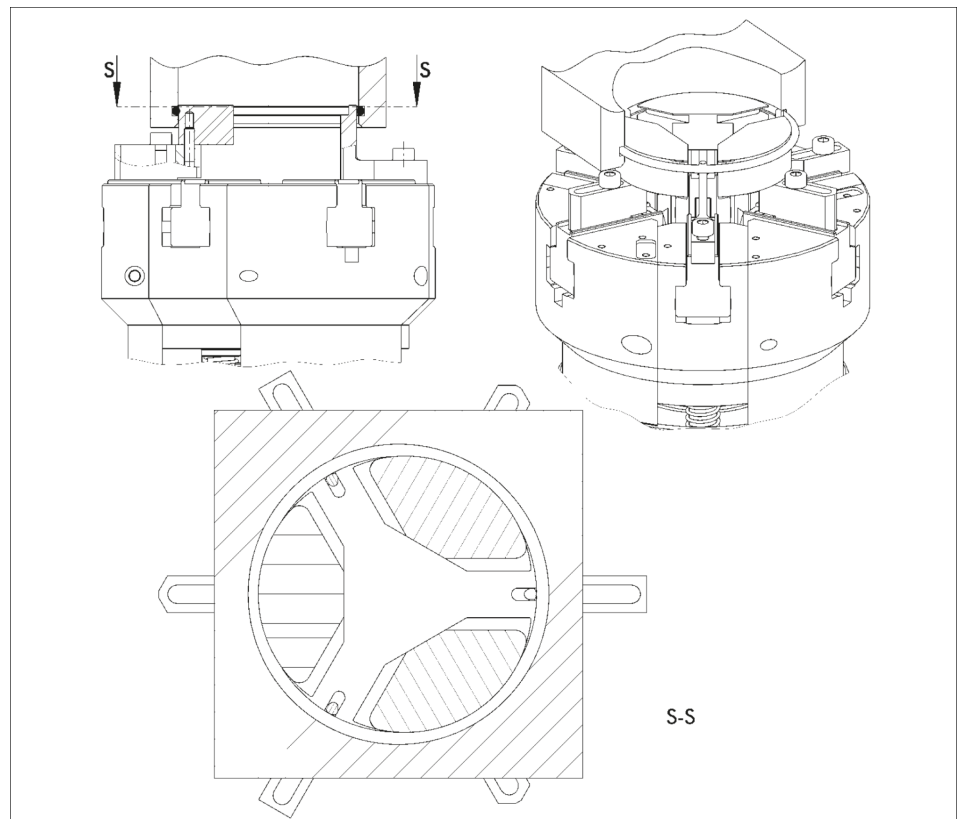

Internal assembly IM_1.9

The seal is pushed into the groove at the remaining three locations.

NOTE

The position of the assembly fingers in the step Internal assembly IM_1.9 is not monitored!

5.6.10 Internal assembly IM_1.10

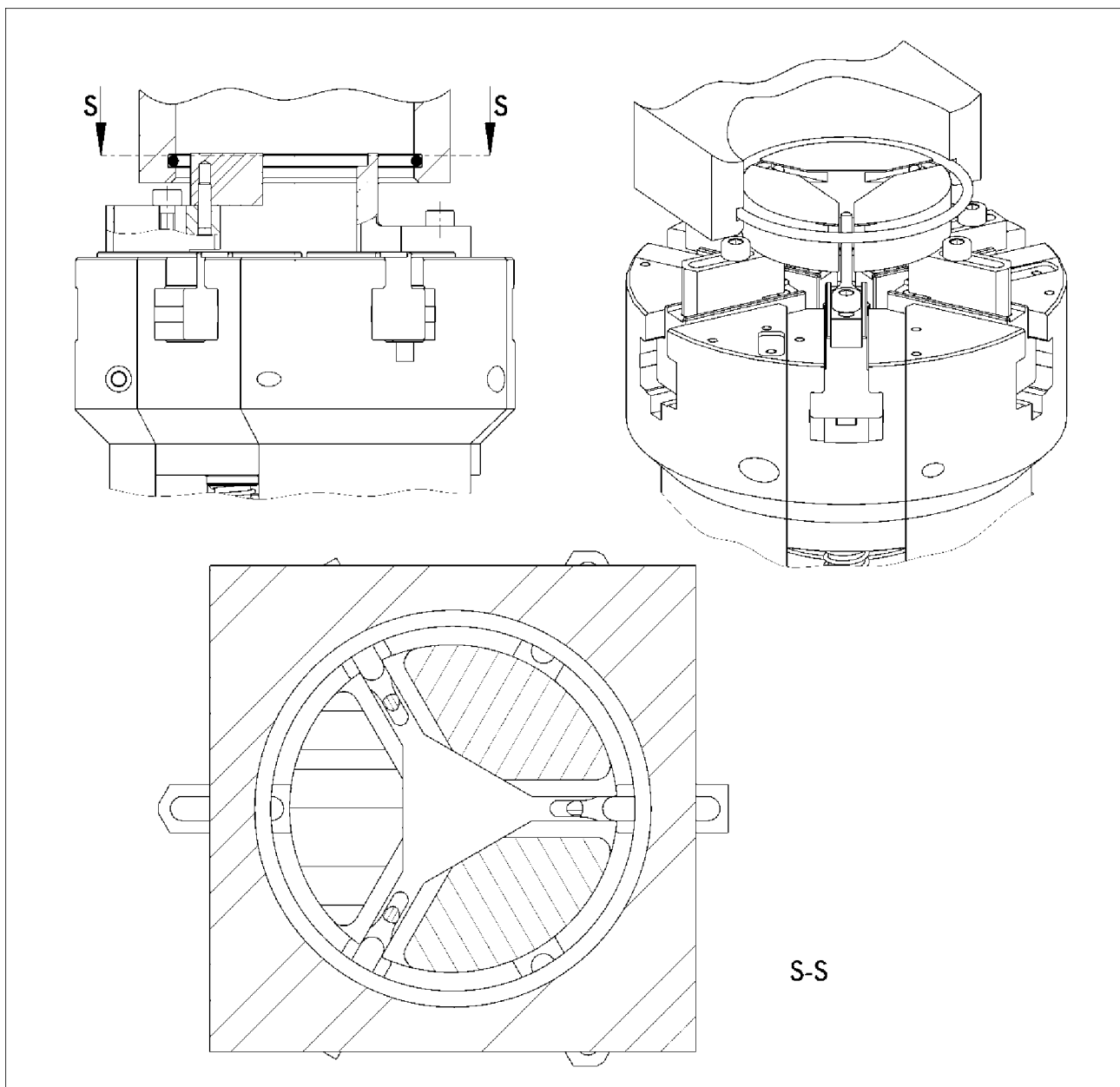

Internal assembly IM_1.10

In the final step, the assembly fingers and the segment jaws are moved toward the inside, i.e. the gripper, triple jaw A and triple jaw B are closed (compressed air connection (1) pressurised, compressed air connection (4) not pressurised).

The internal assembly cycle is completed and the gripper can subsequently be moved out of the assembly bore.

6 Troubleshooting

6.1 Checking the opening and closing times

If you cannot reach the opening and closing times mentioned in the latest catalog, please check the following:

1. Flow control valves are opened to the maximum extent possible? (Movement still has to be shock-free!)
2. Inner diameter of air hoses is sufficient for the gripper's air consumption?
3. Air hose between valve and gripper is as short as possible?
4. Flow rate of valve is sufficient for the gripper's air consumption?

If you still cannot achieve the cycle times mentioned in the latest catalog, we recommend the use of quick-air-vent-valves directly at the gripper.

7 Maintenance

7.1 Notes

Original spare parts

Use only original spare parts of SCHUNK when replacing spare and wear parts.

Replacement of the housing and base jaws

The base jaws and the guides in the housing are matched to each other. To replace these parts, send the product to SCHUNK with a repair order.

7.2 Utensils required for maintenance

Position of the item numbers ▶ 7.9 [84]:

Tools	Torque wrench
Grease ▶ 7.4 [76]	- SCHUNK grease 1
	- SCHUNK grease 1
Adhesive	Adhesive from Weicon 302-41 (40-45/63/ 64)

Equivalent adhesives and activators from other manufacturers may be used.

7.3 Maintenance and servicing intervals

NOTICE

Material damage due to hardening lubricants!

Lubricants harden more quickly at temperatures above 60°C, leading to possible product damage.

- Reduce the lubricant intervals accordingly.

Interval [Mio. cycles]	2
------------------------	---

Carry out maintenance on the gripper once every 2 million cycles. During the maintenance work, certain parts must be installed with oil or grease (basic greasing).

All seals of the gripper must be replaced during each maintenance ▶ 1.4.1 [7]. The complete seal set is available from SCHUNK.

7.4 Lubricants/Lubrication points (basic lubrication)

During maintenance, treat all greased areas with lubricant. Thinly apply lubricant with a lint-free cloth. SCHUNK recommends the lubricants listed.

Lubricant point	Lubricant
Metallic sliding surfaces	SCHUNK grease 1
Seals and sealing surfaces	SCHUNK grease 1
Bore hole at the piston	SCHUNK grease 1

Details regarding SCHUNK lubricant designations are available at schunk.com/lubricants.

The product contains food-compliant lubricants as standard. **The requirements of standard EN 1672-2:2020 are not fully met.**

NOTE

- Change contaminated food-compliant lubricant.
- Observe information in the safety data sheet from the lubricant manufacturer.

7.5 Screw tightening torque

Position of the item numbers ▶ 7.9 [84] ▶ 4.6.3 [34]

Item	40	41	42	43	44	45	80
	0,8 Nm	2,7 Nm	5,8 Nm	3,1 Nm	0,8 Nm	0,8 Nm	0,1 Nm

7.6 Gripper design

The ORG 85 consists of three assembly groups.

No.	Assembly group ORG
Assembly group 1	Triple jaw A unit
Assembly group 2	Triple jaw B unit
Assembly group 3	Drive unit triple jaw B

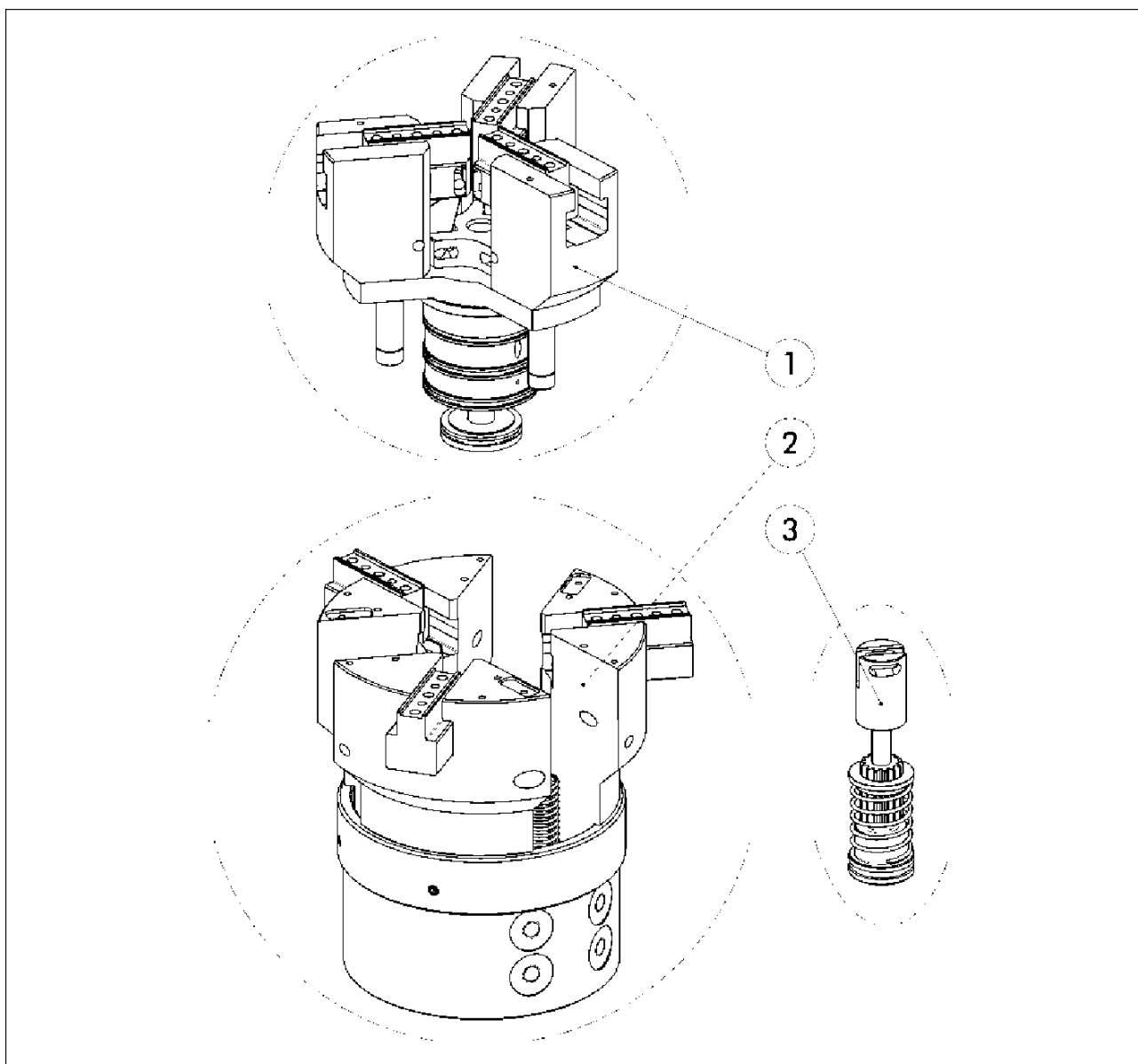

Gripper design

7.7 Disassembling the gripper

Position of the item numbers ▶ 4.2.2 [20]; ▶ 7.9 [84]

Assembly group 1, triple jaw unit A ▶ 7.6 [77] must be disassembled first:

1. Remove all compressed air connections ((1), (2) and (3)) from the gripper, except for compressed air connection (4). You must make sure that only compressed air connection (4) remains connected!
2. To be able to dismantle assembly group 1, triple jaw B must be completely open. The end position must therefore be set so that triple jaw B is completely open ▶ 4.5 [29].



⚠ WARNING

Risk of injury due to spring forces!

The triple jaw units A (5) and B (12) and stroke adjustment ring (7) are under spring tension.

Carefully disassemble the product.

1. Load compressed air connection (4) with compressed air (triple jaw B must open completely).
2. Loosen countersunk head screw (40) from the piston Z-stroke (3).
3. You can now pull assembly group 1 together with the compression springs (25) toward the top and out of the gripper.

7.7.1 Disassembling assembly group 1 (Triple jaw unit A)

Position of the item numbers ▶ 7.9 [84]

NOTE

Turn off the compressed air supply for all compressed air connections and detach all compressed air lines from the gripper!

1. Mark the assembly position of the base jaws (16) in the base bodies triple jaw A (5).
2. Detach the three cylindrical pins (60) which connect the base jaws (16) with the angle levers triple jaw A (17).
3. Pull the base jaws (16) radially out of the base body triple jaw A (5).
4. Detach the three cylindrical pins (69) which connect the fork head (14) with the angle levers triple jaw A (17).

5. Detach the three cylindrical pins (60) supporting the angle levers triple jaw A (17) in the base body triple jaw A (5).
6. The three angle levers triple jaw A (17) can be removed.
7. Unscrew the three screws (42) with the spacer sleeves (6).
8. Remove the three base body triple jaws A (5) toward the top from the flange (10).
9. Detach the six cylindrical pins (61) from the flange (item 10).
10. Detach the cylindrical bushing (8) from the flange (10).
11. Loosen the screw (44) connecting the piston rod (9) with the triple jaw A piston (15).
12. Turn the set screw (45) out of the piston rod (9).
13. Pull the fork head (14) toward the top out of the flange (10).
14. Turn the piston rod (9) upward out of the fork head (14).

NOTE

Assembly is carried out in reverse order whereby the following notes need to be observed for the assembly of assembly group 1:

1. Observe notes in this chapter ▶ 7.1 [□ 75], the necessary utensils for maintenance ▶ 7.2 [□ 75] as well as the screw tightening torques ▶ 7.5 [□ 76].
2. The base jaws (16) must be assigned to the base bodies triple jaw A (5) which were marked earlier!
3. All nine cylindrical pins (60 and 69) must be positioned in the centre of angle lever triple jaw A (17)!
4. The set screw (45) is acting as anti-rotation device for the screw (44). That means, after the assembling of the piston (15) and the screw (44), the screw (44) has to be clamped with the set screw (45)!

7.7.2 Disassembling assembly group 2 (Triple jaw unit B)

NOTE

Turn off the compressed air supply for all compressed air connections and detach all compressed air lines from the gripper!

NOTE

To disassemble assembly group 2, the stroke of triple jaw B must be completely opened! Therefore set the end position so that triple jaw B is completely opened ▶ 4.5 [□ 29].

- Mark the assembly position of the base bodies triple jaw B (12) on the housing (1).
1. Loosen the six screws (43).
 2. Pull the three base body triple jaws B (12) with the stroke adjustment ring (7) axially toward the top and out of the housing (1).
 3. Push three base body triple jaws B (12) with the drive units triple jaw B radially towards the centre axis to disassemble the stroke adjustment ring (7).
 4. Loosen the two set screws (65) from the stroke adjustment ring.
 5. The base body triple jaw B (12) must now be separated from the drive unit triple jaw B.
 6. Use a vice, for example, to press the base body triple jaw B (12) and the drive unit triple jaw B together

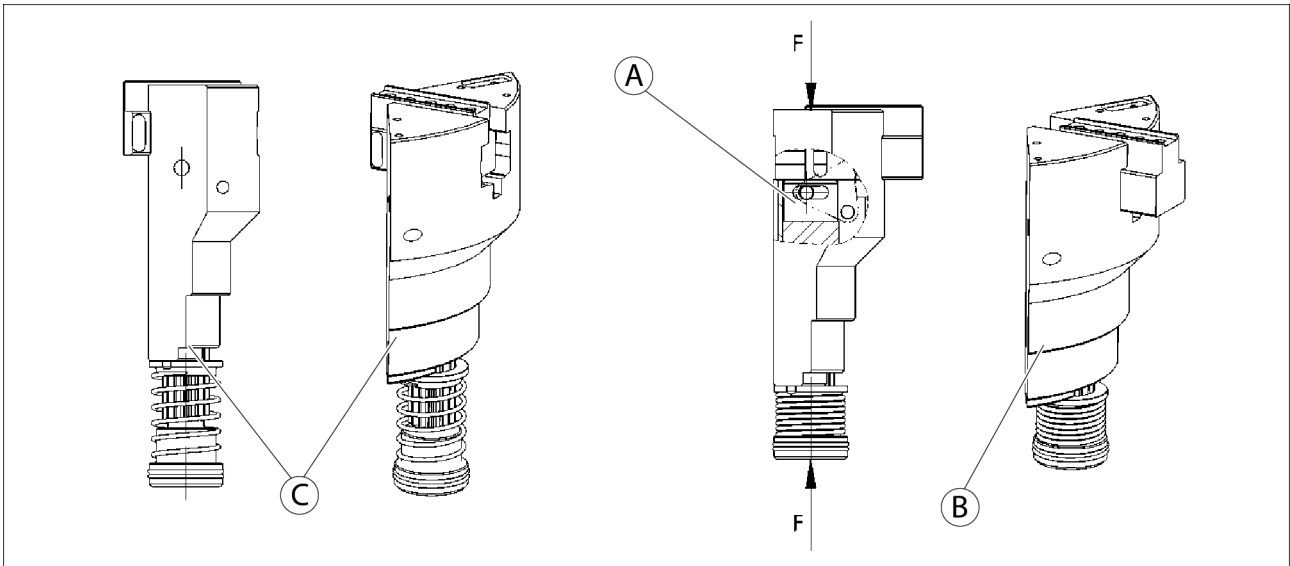

Disassembly of base body with drive unit triple jaw B

A	Transverse bore and elongated hole concentric	B	base body pressed together with drive unit triple jaw B
C	base body with drive unit triple jaw B		

7. By pressing the unit together, the transverse bore in the base body triple jaw B (12) is concentric with the elongated hole in the pressure pin (11).
8. You can detach the three cylindrical pins (13) connecting the angle levers of triple jaw B (18) with the pressure pin (11) only now.
9. Detach the three cylindrical pins (60) supporting the angle levers of triple jaw B (18) in base body triple jaw A (12).

10. Pull the base jaws (16) radially out of the base body triple jaw B (12). (Note: angle lever triple jaw B (18) must be turned into the base jaw (16) for this purpose.)
11. Detach the three cylindrical pins (60) connecting the angle levers of triple jaw B (18) with the base jaws (16).
12. Loosen the three screws (40) from the housing cover (2) and pull it and the piston Z-stroke (3) toward the back out of the housing (1).
13. Detach the six cylindrical pins (62) from the housing (1).

NOTE

Assembly is carried out in reverse order whereby the following notes need to be observed for the assembly of assembly group 2:

1. Observe notes in this chapter ▶ 7.1 [□ 75], the necessary utensils for maintenance ▶ 7.2 [□ 75] as well as the screw tightening torques ▶ 7.5 [□ 76].
2. The three cylindrical pins (13) must be pressed into the centre of the angle lever triple jaw B (18) with an assembly rod, see Figure 49. Please observe the exact assembly dimension and the exact assembly position of the cylindrical pins (13).

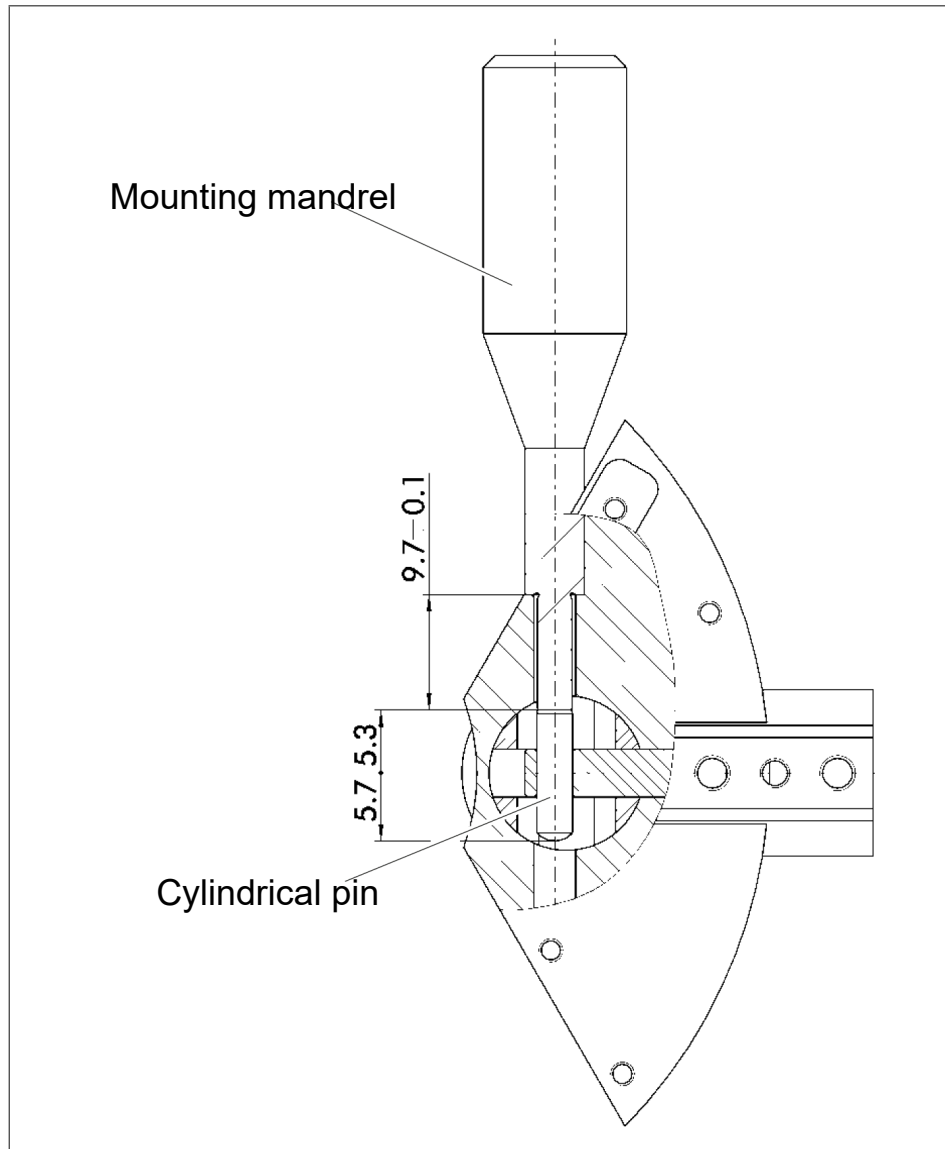

Assembly of cylindrical pins (13)

- 3.** All other cylindrical pins (60) connecting the base jaws (16) with the angle levers triple jaw B (18) must also be positioned in the centre!
- 4.** The base jaws triple jaw B (12) must be fastened on the previously marked positions on the housing (1)!

7.7.3 Disassembly of assembly group 3 (Drive unit triple jaw B)

1. Loosen the set screw (63) from the drive piston triple jaw B (4).
2. Unscrew the screw (41).
3. Unscrew the pressure pin (11) toward the top out of the drive piston of triple jaw B (4).

NOTE

Assembly is carried out in reverse order whereby the following notes need to be observed for the assembly of assembly group 3:

1. Observe notes in this chapter ▶ 7.1 [☐ 75], the necessary utensils for maintenance ▶ 7.2 [☐ 75] as well as the screw tightening torques ▶ 7.5 [☐ 76].
2. Check after assembling items: (4), (41), (66) and (11) whether pressure pin (11) can be easily turned by hand! It must be easily turned along the entire adjustment range of 12 mm!
3. The pressure pin (11) must be completely unscrewed before the assembly can be continued! This means that the distance between the face side of the diameter 13 mm of the pressure pin (11) and end face of the drive piston triple jaw B (4) must be 12 mm!

NOTE

These points must be observed with all three drive units of triple jaw B!

7.8 Servicing the product

Maintenance

- Clean all parts thoroughly and check for damage and wear.
- Treat all greased areas with lubricant.
 - ▶ 7.4 [☐ 76]
- Oil or grease bare external steel parts.
- Replace all wear parts / seals.
 - Position of the wearing parts ▶ 7.9 [☐ 84]
 - Seal kit ▶ 1.4.1 [☐ 7]

7.9 Assembly drawing

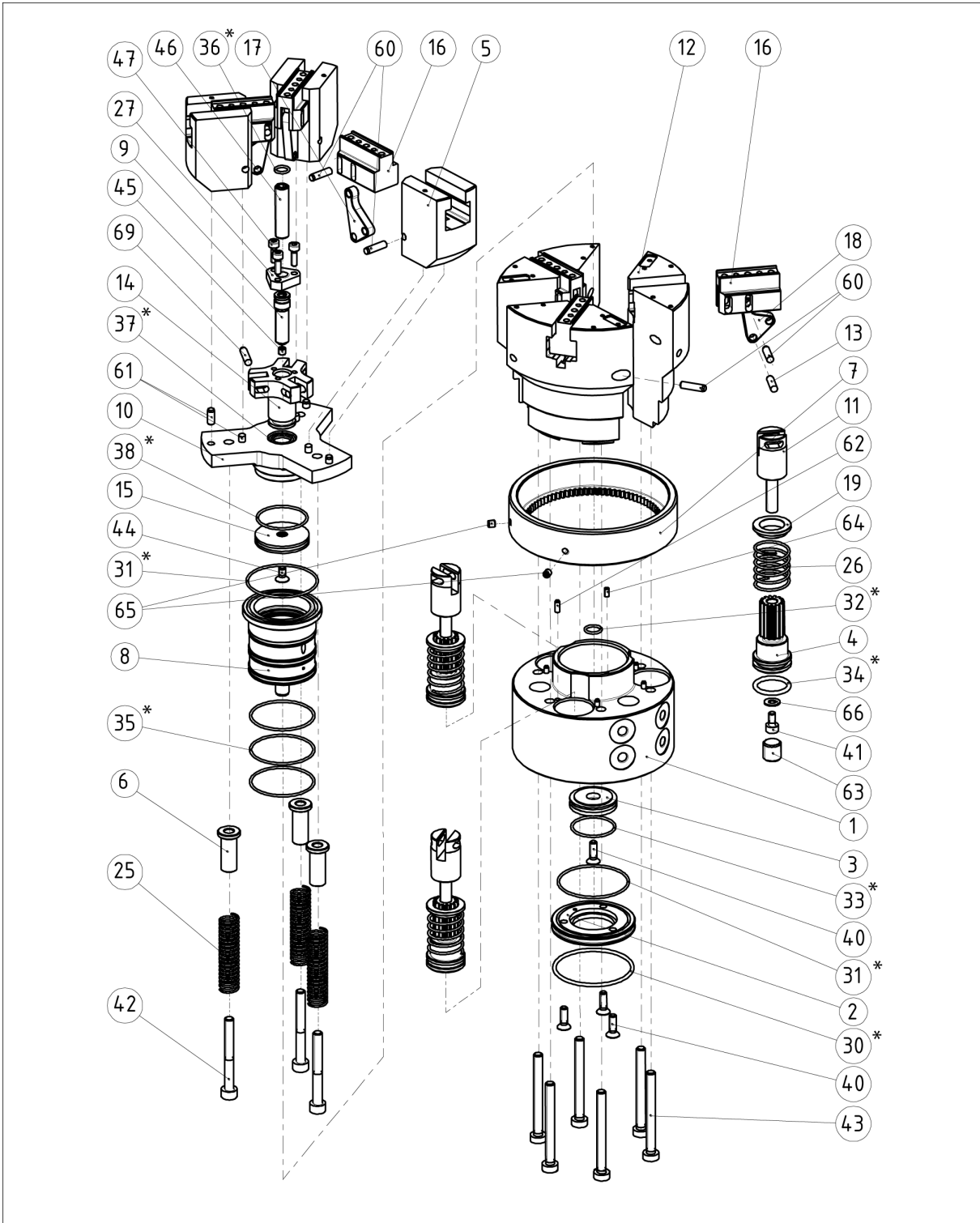

Exploded view ORG 85

* Wearing part, replace during maintenance.
Included in the seal kit. Seal kit can only be ordered completely.

8 Translation of the original declaration of incorporation

in terms of the Directive 2006/42/EG, Annex II, Part 1 Section B.

Manufacturer/
Distributor SCHUNK SE & Co. KG
Spanntechnik | Greiftechnik | Automatisierungstechnik
Bahnhofstr. 106 – 134
D-74348 Lauffen/Neckar

We hereby declare that the partly completed machine described below

Product designation: 0-ring gripper / ORG /pneumatic
ID number 0304120

meets the following basic occupational health and safety of the Machinery Directive 2006/42/EC:

No. 1.1.1, No. 1.1.2, No. 1.1.3, No. 1.1.5, No. 1.3.2, No. 1.5.3, No. 1.5.4, No. 1.5.6, No. 1.5.8, No. 1.5.10, No. 1.5.11, No. 1.5.13

The partly completed machinery may not be put into operation until it has been confirmed that the machine into which the partly completed machinery is to be installed complies with the provisions of the Machinery Directive (2006/42/EC). The declaration shall be rendered invalid if modifications are made to the product.

Applied harmonized standards, especially:

EN ISO 12100:2010 Safety of machinery – General principles for design –
Risk assessment and risk reduction

The special technical documentation according to Annex VII, Part B, belonging to the partly completed machine, has been created.

Person authorized to compile the technical documentation:
Stefanie Walter, Address: see manufacturer's address

Signature: see original declaration

Lauffen/Neckar, June 2025

Dr.-Ing. Manuel Baumeister,
Head of Systems Engineering,
Technology & Innovation

9 UKCA declaration of incorporation

in accordance with the Supply of Machinery (Safety) Regulations 2008.

Manufacturer/ Distributor SCHUNK Intec Limited
Clamping and gripping technology
3 Drakes Mews, Crownhill
MK8 0ER Milton Keynes

We hereby declare that on the date of the declaration the following partly completed machine complied with all basic safety and health regulations found in the "Supply of Machinery (Safety) Regulations 2008".

The declaration shall be rendered invalid if modifications are made to the product.

Product designation: O-ring gripper / ORG / pneumatic
ID number 0304120

The partly completed machine may not be put into operation until it has been confirmed that the machine into which the partly completed machine is to be installed complies with the provisions of the "Supply of Machinery (Safety) Regulations 2008".

Applied harmonized standards, especially:

EN ISO 12100:2010 Safety of machinery – General principles for design –
Risk assessment and risk reduction

The special technical documentation according to Annex VII, Part B, belonging to the partly completed machine, has been created.

Person authorized to compile the technical documentation:
Marcel Machado, address: refer to manufacturer's address

Lauffen/Neckar, June 2025



Dr.-Ing. Manuel Baumeister,
Head of Systems Engineering,
Technology & Innovation

10 Information on the RoHS Directive, REACH Regulation and Substances of Very High Concern (SVHC)

RoHS Directive

SCHUNK products are classified as "large-scale stationary installations" or as "large-scale stationary industrial tools" within the meaning of Directive 2011/65/EU and its extension 2015/863/EU "on the restriction of the use of certain hazardous substances in electrical and electronic equipment (RoHS)", or fulfill their intended function only as part of one. Therefore products from SCHUNK do not fall within the scope of the directive at this time.

REACH Regulation

Products from SCHUNK fully comply with the regulations of Regulation (EC) No. 1907/2006 "concerning the Registration, Evaluation, Authorization and Restriction of Chemicals (REACH)" and its amendment 2022/477. SCHUNK attaches great importance to completely avoiding chemicals of concern to humans and the environment wherever possible.

Only in rare exceptional cases do SCHUNK products contain SVHC substances on the candidate list with a mass content above 0.1%. In accordance with Article. 33 (1) of Regulation (EC) No. 1907/2006, SCHUNK complies with its duty to "communicate information on substances in articles" and lists the components concerned and the substances used in an overview that can be viewed at schunk.com/SVHC.

Signature: see original declaration

Lauffen/Neckar, June 2025

Dr.-Ing. Manuel Baumeister,
Head of Systems Engineering,
Technology & Innovation



SCHUNK SE & Co. KG
Spanntechnik | Greiftechnik | Automatisierungstechnik

Bahnhofstr. 106 - 134
D-74348 Lauffen/Neckar
Tel. +49-7133-103-0
info@de.schunk.com
schunk.com

Folgen Sie uns | *Follow us*



Wir drucken nachhaltig | *We print sustainable*