



# Assembly and operating manual

## PFH 150– 300

### 2-finger parallel gripper

Translation of original operating  
manual

Hand in hand for tomorrow

## Imprint

### Copyright:

This manual is protected by copyright. The author is SCHUNK SE & Co. KG.  
All rights reserved.

### Technical changes:

We reserve the right to make technical improvements.

**Document number:** 389270

**Version:** 12.00 | 12/15/2025 | en-US

Dear Customer

Dear Customer,

Thank you for putting your trust in our products and our family-owned company, the leading technology supplier of robots and production machines.

Our team is always available to answer any questions on this product and other solutions. We look forward to your challenging questions. We will find a solution!

Best regards,

Your SCHUNK team

Customer Management

Tel. +49-7133-103-2503

Fax +49-7133-103-2189

cmg@de.schunk.com



**Please read the operating manual in full and keep it close to the product.**

## Table of Contents

<b>1</b>	<b>General .....</b>	<b>5</b>
1.1	About this Manual .....	5
1.1.1	Illustration of safety notes .....	5
1.1.2	Applicable documents .....	6
1.1.3	Sizes.....	6
1.1.4	Versions .....	6
1.2	Warranty .....	6
1.3	Scope of delivery.....	6
1.3.1	Accessory kit .....	7
1.4	Accessories .....	7
1.4.1	Sensors .....	8
1.4.2	Seal kit .....	8
<b>2</b>	<b>Basic safety notes.....</b>	<b>9</b>
2.1	Appropriate use .....	9
2.2	Structural changes.....	9
2.3	Spare parts .....	9
2.4	Gripper fingers .....	10
2.5	Ambient conditions and operating conditions .....	10
2.6	Personnel qualification .....	10
2.7	Personal protective equipment .....	11
2.8	Notes on safe operation.....	12
2.9	Transport.....	12
2.10	Malfunctions.....	12
2.11	Disposal .....	13
2.12	Fundamental dangers .....	13
2.12.1	Protection during handling and assembly .....	13
2.12.2	Protection during commissioning and operation .....	14
2.12.3	Protection against dangerous movements .....	14
2.12.4	Protection against electric shock.....	14
2.13	Notes on particular risks .....	15
<b>3</b>	<b>Technical data .....</b>	<b>17</b>
<b>4</b>	<b>Assembly.....</b>	<b>18</b>
4.1	Assembly of the top jaws .....	18
4.2	Connections .....	19
4.2.1	Mechanical connection.....	19
4.2.2	Pneumatic connection.....	20

4.3	Mount the sensors.....	22
4.3.1	Inductive proximity switch IN 80 .....	22
4.3.2	MMS 22/RMS 22 magnetic switch.....	25
<b>5</b>	<b>Troubleshooting.....</b>	<b>27</b>
5.1	Product does not move? .....	27
5.2	Product does not execute a complete stroke? .....	27
5.3	Product opens or closes jerkily? .....	27
5.4	Gripping force gets weaker.....	28
5.5	Opening and closing times are not attained?.....	28
<b>6</b>	<b>Maintenance .....</b>	<b>29</b>
6.1	Notes.....	29
6.2	Maintenance and lubrication intervals.....	29
6.3	Lubricants/greasing areas (basic lubrication) .....	29
6.4	Disassembling the product .....	30
6.5	Servicing and assembling the product .....	31
6.5.1	Tightening torque for screws .....	32
6.5.2	Revolutions of the fitting screw .....	32
6.6	Assembly drawing .....	33
<b>7</b>	<b>Translation of the original declaration of incorporation .....</b>	<b>34</b>
<b>8</b>	<b>UKCA declaration of incorporation .....</b>	<b>35</b>
<b>9</b>	<b>Information on the RoHS Directive, REACH Regulation and Substances of Very High Concern (SVHC) .....</b>	<b>36</b>

# 1 General

## 1.1 About this Manual

This manual contains important information for the safe, correct use of the product.

The manual is an integral part of the product and must be kept accessible by personnel at all times.

Personnel must have read and understood this manual before beginning any work. The observance of all safety notes in this manual is the precondition for all safe working.

Besides this manual, other documents which apply are those listed under ▶ 1.1.2 [ 6].

**NOTE:** The illustrations in this manual are intended to provide a basic understanding and may deviate from the actual version.

### 1.1.1 Illustration of safety notes

To make risks clear, the following signal words and symbols are used for safety notes.



#### **⚠ DANGER**

##### **Danger to individuals!**

Ignoring a safety note such as this will certainly lead to irreversible injury and even death.



#### **⚠ WARNING**

##### **Danger to individuals!**

Ignoring a safety note such as this can lead to irreversible injury and even death.



#### **⚠ CAUTION**

##### **Danger to individuals!**

Non-observance can cause minor injuries.

#### **NOTICE**

##### **Material damage!**

Information about avoiding material damage.

### 1.1.2 Applicable documents

- General terms of business \*
- Catalog data sheet of the purchased product \*

The documents labeled with an asterisk (\*) can be downloaded from [schunk.com/downloads](https://schunk.com/downloads).

### 1.1.3 Sizes

This manual applies to the following sizes:

- PFH 150
- PFH 200
- PFH 250
- PFH 300

### 1.1.4 Versions

This operating manual applies to the following variations:

- PFH
- PFH High-temperature (HT)

## 1.2 Warranty

If the product is used as intended, the warranty is valid for 24 months from the date of delivery from the production facility under the following conditions:

- Observance of the specified maintenance and lubrication intervals
- Observance of the ambient conditions and operating conditions

Parts touching the workpiece and wearing parts are not part of the warranty.

## 1.3 Scope of delivery

The scope of delivery includes:

- 2-finger parallel gripper PFH in the version ordered
- Safety information (product-specific instructions available online)
- Accessory pack

### 1.3.1 Accessory kit

Contents of the accessory kit:

Designation	ID
4 x centering sleeves $\varnothing 14 \times 8.6 \text{ mm}$	9939381
2x dowel pins ISO 8734 8.0m6 x 20mm	9682058
2 x O-rings, DIN 3771 NBR 70 15.55 x 2.62mm	9611222

### 1.4 Accessories

The following accessories, which must be ordered separately, are required for the product:

- 2 Top jaws
- Sensors, with extension cables if necessary ▶ [1.4.1](#) [ 8 ]

A wide range of accessories is available for this product.

For information regarding which accessory articles can be used with the corresponding product variants, see catalog data sheet.

### 1.4.1 Sensors

Designation	Type
Inductive proximity switches	IN 80-S
Magnetic switch	MMS22
	RMS22

- Exact type designation of the compatible sensors see catalog.
- Information on handling sensors is available at [schunk.com](http://schunk.com) or from SCHUNK contact persons.

### 1.4.2 Seal kit

Seal kit for	ID number
PFH 150 – 300	0302025

contents of the sealing kit, ► 6.6 [📄 33].

## 2 Basic safety notes

### 2.1 Appropriate use

The product is designed exclusively for gripping and temporarily holding workpieces or objects.

- The product may only be used within the scope of its technical data, ▶ 3 [17].
- The product is intended for installation in a machine/ automated system. The applicable guidelines for the machine/ automated system must be observed and complied with.
- The product is intended for industrial and industry-oriented use. Its use outside enclosed spaces is only permitted if suitable protective measures are taken against outdoor exposure. The product is not suitable for use in salty air.
- The product can be used within the permissible load limits and technical data for holding workpieces during simple machining operations, but is not a clamping device according to EN 1550:1997+A1:2008.
- Appropriate use of the product includes compliance with all instructions in this manual.
- Any use that exceeds or differs from the appropriate use is regarded as misuse.

### 2.2 Structural changes

#### Implementation of structural changes

Modifications, changes or reworking, e.g. additional threads, holes, or safety devices, can damage the product or impair its functionality or safety.

- Structural changes should only be made with the written approval of SCHUNK.

### 2.3 Spare parts

#### Use of unauthorized spare parts

Using unauthorized spare parts can endanger personnel and damage the product or cause it to malfunction.

- Use only original spare parts and spares authorized by SCHUNK.

## 2.4 Gripper fingers

### Requirements of gripper fingers

Accumulated energy can make the product unsafe and risk the danger of serious injuries and considerable material damage.

- Only change gripper fingers if no residual energy can be released.
- Make sure that the product and the gripper finger are sufficient in size for the workpiece.

## 2.5 Ambient conditions and operating conditions

### Required ambient conditions and operating conditions

Incorrect ambient and operating conditions can make the product unsafe, leading to the risk of serious injuries, considerable material damage and/or a significant reduction to the product's life span.

- Make sure that the product is only used within its defined application parameters, ▶ 3 [17].
- Make sure that the product is a sufficient size for the workpiece.
- Make sure that the environment is free from splash water and vapors as well as from abrasion or processing dust. Exceptions are products that are designed especially for contaminated environments.

## 2.6 Personnel qualification

### Inadequate qualification of personnel

Work on the product by inadequately qualified personnel can lead to serious injuries and considerable material damage.

- Order all work to be performed only by appropriately qualified personnel.
- Personnel must have read and understood the complete manual before beginning any work on the product.
- Observe national accident prevention regulations and the general safety notes.

The following personnel qualifications are required for the various types of work on the product:

<b>Trained electrician</b>	Due to their technical training, knowledge and experience, trained electricians are able to work on electrical systems, recognize and avoid possible dangers and know the relevant standards and regulations.
<b>Qualified personnel</b>	Due to its technical training, knowledge and experience, qualified personnel is able to perform the delegated tasks, recognize and avoid possible dangers and knows the relevant standards and regulations.
<b>Instructed person</b>	Instructed persons have been instructed by the user regarding the tasks entrusted to them and the potential dangers of inappropriate behavior.
<b>Manufacturer's service personnel</b>	The manufacturer's service personnel have the specialized training, knowledge, and experience to perform the work entrusted to them and to recognize and avoid potential dangers.

## 2.7 Personal protective equipment

### Use of personal protective equipment

Personal protective equipment serves to protect staff in the event of a danger that may interfere with their health or safety at work.

- When working on and with the product, observe the occupational health and safety regulations and wear the required personal protective equipment.
- Observe the valid safety and accident prevention regulations.
- Wear protective gloves to guard against sharp edges and corners or rough surfaces.
- Wear heat-resistant protective gloves when handling hot surfaces.
- Wear protective gloves and safety goggles when handling hazardous substances.
- Wear close-fitting protective clothing and also wear long hair in a hairnet when dealing with moving components.

## 2.8 Notes on safe operation

### Incorrect manner of working by personnel

An incorrect manner of working can make the product unsafe and risk the danger of serious injuries and considerable material damages.

- Avoid any manner of working that may interfere with the function and operational safety of the product.
- Use the product as intended.
- Observe the safety notes and assembly instructions.
- Do not expose the product to any corrosive media. Products for special ambient conditions are excluded.
- Rectify malfunctions as soon as they occur.
- Observe the care and maintenance instructions.
- Observe the current safety, accident prevention, and environmental protection regulations for the application field of the product.

## 2.9 Transport

### Handling during transport

Incorrect handling during transport can make the product unsafe and risk serious injuries and considerable material damage.

- When handling heavy weights, use lifting equipment to lift the product and transport it by appropriate means.
- During transport and handling, secure the product to prevent it from falling.
- Do not walk under suspended loads.

## 2.10 Malfunctions

### Behavior in case of malfunctions

- Immediately remove the product from operation and report the malfunction to the responsible departments/persons.
- Order appropriately trained personnel to rectify the malfunction.
- Do not recommission the product until the malfunction has been rectified.
- Test the product after a malfunction to establish whether it still functions properly and no increased risks have arisen.

## 2.11 Disposal

### Handling of disposal

Incorrect handling during disposal can make the product unsafe and risks serious injuries and considerable material and environmental harm.

- Follow local regulations on dispatching product components for recycling or orderly disposal.

## 2.12 Fundamental dangers

### General

- Observe safety distances.
- Never deactivate safety devices.
- Before commissioning the product, take appropriate protective measures to secure the danger zone.
- Disconnect power sources before installation, modification, maintenance, or calibration. Ensure that no residual energy remains in the system.
- If the energy supply is connected, do not move any parts by hand.
- Do not reach into the open mechanism or movement area of the product during operation.

### 2.12.1 Protection during handling and assembly

#### Incorrect handling and assembly

Incorrect handling and assembly can make the product unsafe and pose a risk of serious injuries and considerable material damage.

- Order all work to be performed only by appropriately qualified personnel.
- For all work, secure the product against accidental operation.
- Observe the relevant accident prevention regulations.
- Use suitable assembly and transport equipment and take precautions to prevent jamming and crushing.

#### Incorrect lifting of loads

Falling loads can cause serious injuries and even death.

- Stand clear of suspended loads and do not step within their swiveling range.
- Never move loads without supervision.
- Do not leave suspended loads unattended.

## 2.12.2 Protection during commissioning and operation

### Falling or violently ejected components

Falling and violently ejected components can cause serious injuries and even death.

- Take appropriate protective measures to secure the danger zone.
- Never step into the danger zone during operation.

## 2.12.3 Protection against dangerous movements

### Unexpected movements

If the system still retains residual energy, serious injuries can be caused while working on the product.

- Switch off the energy supply, ensure that no residual energy remains and secure against inadvertent reactivation.
- Never rely solely on the response of the monitoring function to avert danger. Until the installed monitors become effective, it must be assumed that the drive movement is faulty, with its action being dependent on the control unit and the current operating condition of the drive. Perform maintenance work, modifications, and attachments outside the danger zone defined by the movement range.
- To avoid accidents and/or material damage, human access to the movement range of the machine must be restricted. Limit/prevent accidental access for people in this area through technical safety measures. The protection cover and protective fence must be rigid enough to withstand the maximum possible movement energy. EMERGENCY STOP switches must be easily and quickly accessible. Before commissioning the machine or automated system, check that the EMERGENCY STOP system is working. Prevent operation of the machine if this protective equipment does not function correctly.

## 2.12.4 Protection against electric shock

### Possible electrostatic energy

Components or assembly groups may become electrostatically charged. When the electrostatic charge is touched, the discharge can trigger a shock reaction which may lead to injuries.

- The operator must ensure that all components and assembly groups are included in the local equipotential bonding in line with the applicable regulations.
- The equipotential bonding must be implemented by a specialist electrician in line with the applicable regulations while paying particular attention to the actual conditions in the working environment.
- The effectiveness of the equipotential bonding must be verified by regular safety measurements.

## 2.13 Notes on particular risks



### **⚠ DANGER**

#### **Risk of fatal injury from suspended loads!**

Falling loads can cause serious injuries and even death.

- Stand clear of suspended loads and do not step within their swiveling range.
- Never move loads without supervision.
- Do not leave suspended loads unattended.
- Wear suitable protective equipment.



### **⚠ WARNING**

#### **Risk of injury from objects falling and being ejected!**

Falling and ejected objects during operation can lead to serious injury or death.

- Take suitable protective measures to secure the danger zone.



### **⚠ WARNING**

#### **Risk of injury from sharp edges and corners!**

Sharp edges and corners can cause cuts.

- Wear suitable protective equipment.



### **⚠ WARNING**

#### **Risk of injury due to sudden movements!**

If the energy supply is switched on or if residual energy is still present in the system, this can cause components to move unexpectedly, which may result in serious injuries.

- Before starting any work on the product: Switch off the energy supply and secure against re-connection.
- Ensure that no residual energy remains in the system.



**⚠ WARNING**

**Risk of injury from crushing and impacts!**

Serious injury could occur during movement of the base jaw, due to breakage or loosening of the gripper fingers or if the workpiece is lost.

- Wear suitable protective equipment.
- Do not reach into the open mechanism or the movement area of the product.



**⚠ WARNING**

**Risk of injury due to spring forces!**

Products that use spring force or have maintenance of gripping force contain parts that are under spring tension. This can cause components to move unexpectedly when being dismantled, which may result in serious injuries.

- Dismantle the product carefully.
- Ensure that no residual energy remains in the system.



**⚠ WARNING**

**Risk of injury from objects falling during energy supply failure**

Products with a mechanical gripping force maintenance can, during energy supply failure, still move independently in the direction specified by the mechanical gripping force maintenance.

- Secure the end positions of the product with SCHUNK SDV-P pressure maintenance valves.

### 3 Technical data

Tab.:

Size	150	200	250	300
Weight [kg]	18.9	23.5	28.6	33.6
Pressure medium	Compressed air, compressed air quality according to ISO 8573-1:2010 [7:4:4]			
Compressed air quality	Filtered compressed air [10 µm], dry, oiled or unoled			
Min. pressure [bar]	2			
Max. pressure [bar]	8			
Max. permitted weight per finger [kg]	7	8	9	10
Noise emission [dB(A)]	≤ 70			
IP rating	30			
Min. ambient temperature [°C]	-10			
Max. ambient temperature [°C]	90			

More technical data is included in the catalog data sheet.  
Whichever is the latest version.

## 4 Assembly

### 4.1 Assembly of the top jaws

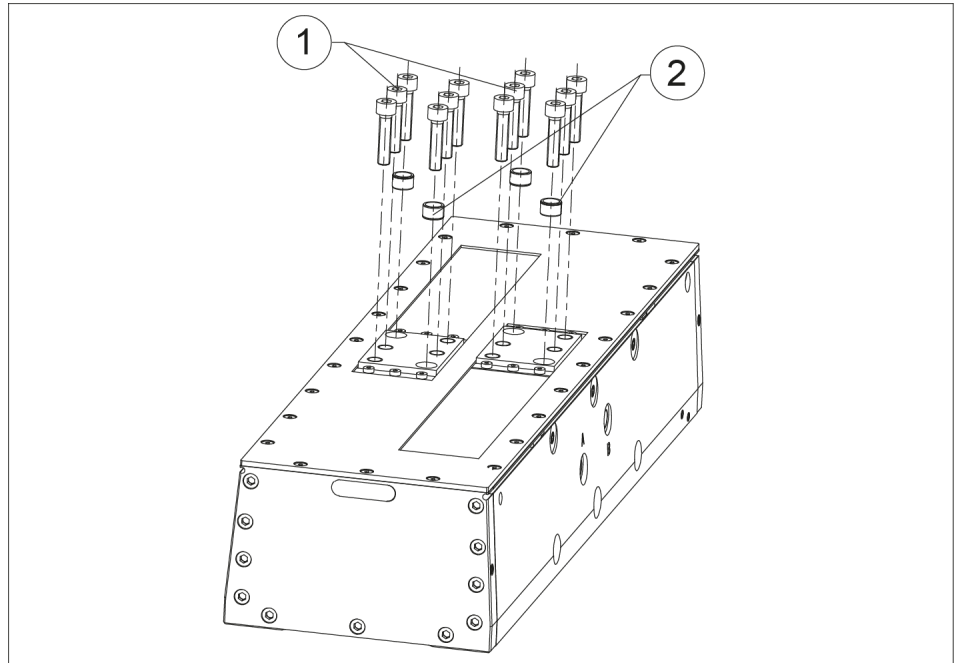

The centering sleeves (2) are included in the scope of delivery.

Item	Mounting	
2	Centering sleeve (4x)	∅ 14 x 8.6

The screws for mounting the top jaws must be provided by the customer:

Item	Mounting	
1	Screw (12x)	M10 14 deep
Maximum tightening torque of screws		40 Nm

## 4.2 Connections

### 4.2.1 Mechanical connection

#### Evenness of the mounting surface

The values apply to the whole mounting surface to which the product is mounted.

Edge length	Permissible unevenness
< 100	< 0.02
> 100	< 0.05

Tab.: Requirements for evenness of the mounting surface (Dimensions in mm)

#### Mounting

The product can be mounted from the front or the side.

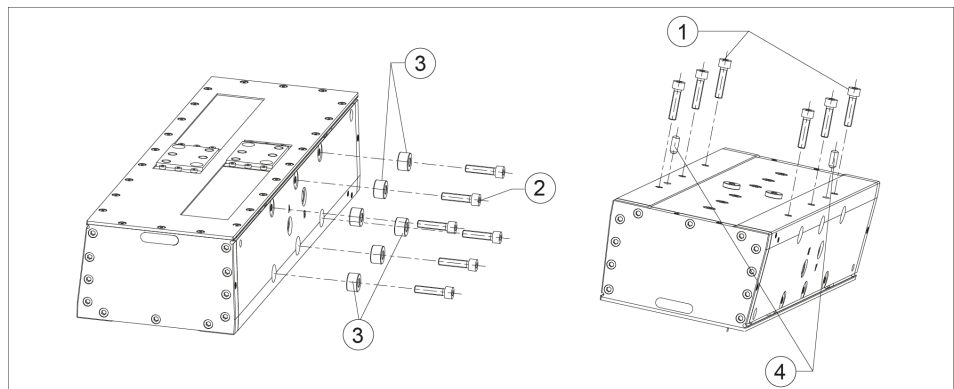

Assembly options

The centering pins (4) are included in the scope of delivery.

Item	Mounting	
4	Cylindrical pin (2x)	DIN 6325 8.0 m6 x 20 mm

### NOTICE

**The gripper will be damaged during assembly if the maximum screw-in depth for the mounting screws is exceeded.**

The maximum screw-in depth for bottom-sided and lateral gripper fastening must always be observed.

The following screws must be provided by the customer:

Item	Screw	
1	Thread diameter and max. screw-in depth when gripper is mounted from the front	M8 15 mm
2	Thread diameter and max. screw-in depth when gripper is mounted from the side	M8 14 mm
Maximum tightening torque of screws		40 Nm

When the gripper is fastened from the side, 6 spacers (3) are required.

The spacers are included in the attachment kit (ID 0302024) and must be ordered separately.

#### 4.2.2 Pneumatic connection

##### NOTICE

##### Damage to the gripper possible!

Exceeding the maximum permissible finger weight or the permissible mass moment of inertia of the fingers can damage the gripper.

- Jaw movement must always be impact- and bounce-free.
- If necessary, provide sufficient throttling and/or damping.
- Observe the information in the catalog data sheet.

##### NOTE

- Observe the requirements for the compressed air supply, ▶ 3 [17].
- In case of compressed air loss (cutting off the energy line), the components lose their dynamic effects and do not remain in a secure position. However, the use of a SDV-P pressure maintenance valve is recommended in this case in order to maintain the dynamic effect for some time. Product variants are also offered with mechanical gripping force via springs, which also ensure a minimum clamping force in the event of a pressure drop.

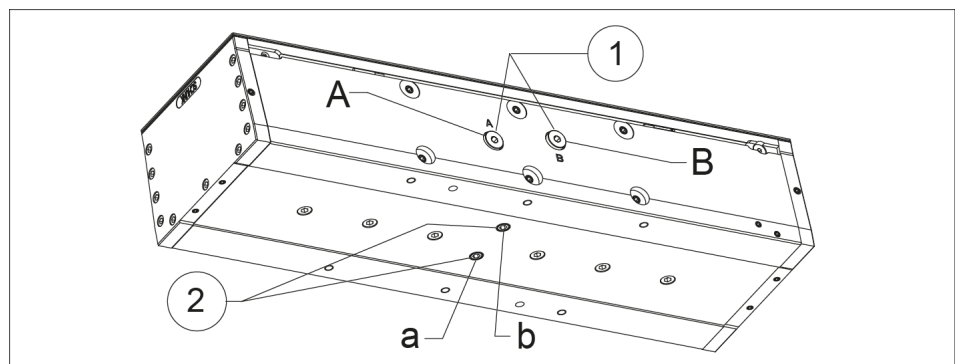

*Air connections*

Item	Connection	Thread
1	Hose connection (A = open, B = close)	G 1/4"
2	Hose connection or Hose-free direct connection (a = open, b = close)	G 1/4"

- Only open the required air connections.
- Seal those main air connections that are not needed using the locking screws from the accessory kit.
- For hose-free direct connections, use the O-rings from the accessory kit.

### 4.3 Mount the sensors

#### NOTE

When mounting and connecting the sensors, observe the Sensor Assembly and Operating Manual.

The product is equipped for the use of sensors.

- For the exact type designations of suitable sensors, please see the catalog data sheet.
- For technical data for the suitable sensors, see Assembly and Operating Manual and catalog data sheet.
  - The Assembly and Operating Manual and catalog data sheet are included in the scope of delivery for the sensors and are available at [schunk.com](http://schunk.com).
- Information on handling sensors is available at [schunk.com](http://schunk.com) or from SCHUNK contact persons.

#### 4.3.1 Inductive proximity switch IN 80

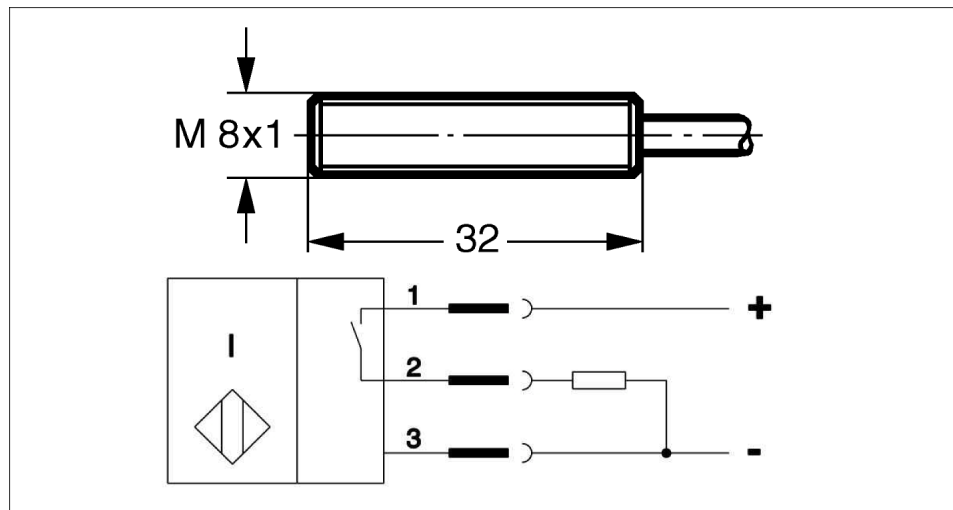

Connection example for IN 80

1	brown	2	black	3	blue
---	-------	---	-------	---	------

The inductive proximity switch used is reverse polarity protected and short-circuit proof.

The following must be observed when handling the proximity switch correctly:

- Do not pull on the sensor cable.
- Do not allow the sensor to dangle by the cable.
- Do not overtighten the fastening screw or clamps.
- Observe the permissible bending radius of the cable (see catalog specifications).
- Avoid contact of the proximity switches with hard objects and chemicals, especially nitric, chromic and sulphuric acid.

The inductive proximity switch is an electronic component that can react sensitively to high-frequency interference or electromagnetic fields.

- Check the attachment and installation of the cable. The distance to high-frequency interference sources and their supply line must be sufficient.
- The parallel connection of several sensor outputs of the same type (npn, pnp) is permitted, but does not increase the permissible load current.
- It should be noted that the leakage current of the individual sensors (approx. 2 mA) is added together.

### Assembly of the proximity switch

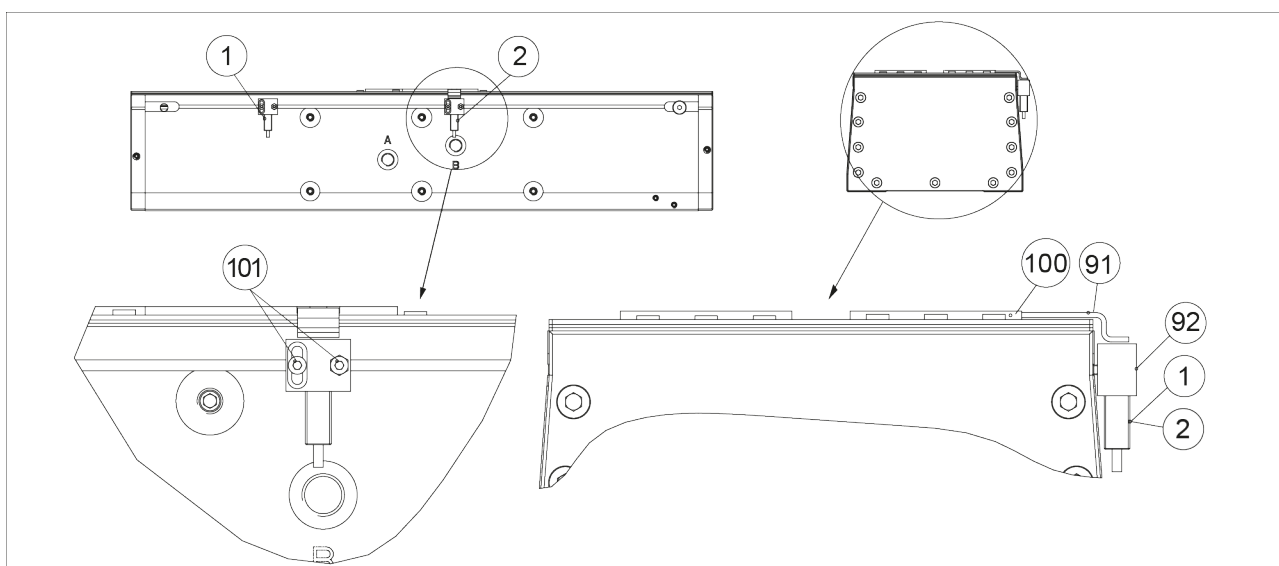

Attachment kit for proximity switch IN 80

#### Gripper open:

1. Set the gripper to the "open" position.
2. Secure control cam (91) with screw (100) on the base jaw.
3. Screw the sliding block (90) to the clamp holder (92).
4. Push the sliding block with clamp holder into the groove of the housing.
5. Insert the proximity switch (1) into the terminal holder (92) as far as it will go.
6. Proximity switch (incl. clamp holder and sliding block) seen from the front of the gripper towards the center of the gripper until the proximity switch switches.
7. Clamp the proximity switch (101) in this position by tightening the screws.
8. Close the gripper and open it again in order to test its functioning.

**Gripper closed:**

1. Set the gripper to the "closed" position.
2. Secure control cam (91) with screw (100) on the base jaw.
3. Screw the sliding block (90) to the clamp holder (92).
4. Push the sliding block with clamp holder into the groove of the housing.
5. Insert the proximity switch (2) into the terminal holder (92) as far as it will go.
6. Slide the proximity switch (incl. bracket and T-nut) from the center of the gripper outwards until the proximity switch switches.
7. Clamp the proximity switch (101) in this position by tightening the screws.
8. Open the gripper and close it again in order to test its functioning.

**Part gripped (O.D. gripping):**

1. Clamp the part to be gripped.
2. Secure control cam (91) with screw (100) on the base jaw.
3. Screw the sliding block (90) to the clamp holder (92).
4. Push the sliding block with clamp holder into the groove of the housing.
5. Insert the proximity switch (2) into the terminal holder (92) as far as it will go.
6. Slide the proximity switch (incl. bracket and T-nut) from the center of the gripper outwards until the proximity switch switches.
7. Clamp the proximity switch (101) in this position by tightening the screws.
8. Open the gripper and close it again in order to test its functioning.

**Part gripped (I.D. gripping):**

1. Clamp the part to be gripped.
2. Secure control cam (91) with screw (100) on the base jaw.
3. Screw the sliding block (90) to the clamp holder (92).
4. Push the sliding block with clamp holder into the groove of the housing.
5. Insert the proximity switch (1) into the terminal holder (92) as far as it will go.

6. Proximity switch (incl. clamp holder and sliding block) seen from the front of the gripper towards the center of the gripper until the proximity switch switches.
7. Clamp the proximity switch (101) in this position by tightening the screws.
8. Close the gripper and open it again in order to test its functioning.

#### 4.3.2 MMS 22/RMS 22 magnetic switch

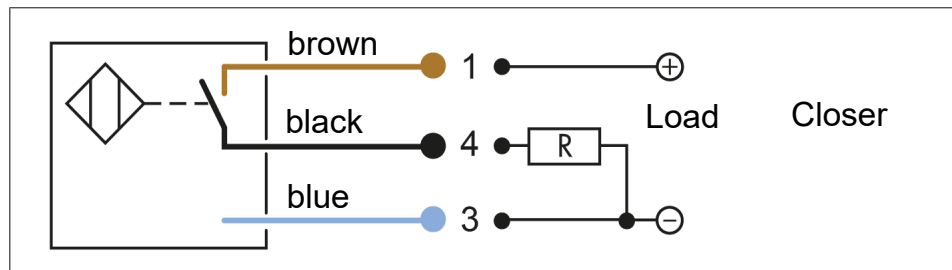
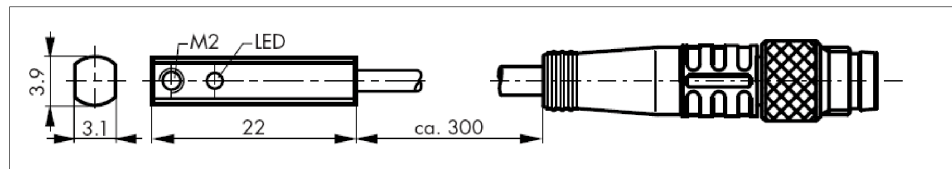

#### NOTICE

##### Risk of damage to the sensor during assembly.

Maximum tightening torque of 30 Ncm for the set-screws.

#### NOTE

**Ferromagnetic components change the switching positions of the sensor. Example: Adapter plate made of mild steel.**

For ferromagnetic adapter plates:

- First mount the product on the adapter plate.
- Then set the switching position of the sensor.

The RMS sensors have a larger hysteresis than the MMS sensors. This means that short gripper strokes may not be able to be monitored with the RMS sensors.

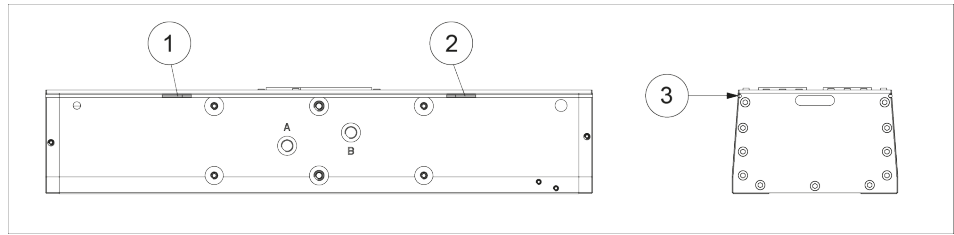

Position of the magnetic switches

- 1 Magnetic switch 1: Gripper "open"

---

- 2 Magnetic switch 2: Gripper "closed"

---

- 3 Free milling for inserting the magnetic switches (on both sides)

---

**Gripper open:**

1. Set the gripper to the "open" position.
2. Push magnetic switch 1 (1) through the free milling (3) into the groove until this switches.
3. Clamp the magnetic switch (1) in the groove in this position by tightening the set-screw.
4. Close the gripper and open it again in order to check its function.

**Gripper closed:**

1. Set the gripper to the "closed" position.
2. Push magnetic switch 2 (2) through the free milling (3) into the groove until this switches.
3. Clamp the magnetic switch (2) in this position in the groove by tightening the set-screw.
4. Open the gripper and close it again in order to test its functioning.

**Part gripped (O.D. gripping):**

1. Clamp the part to be gripped.
2. Push magnetic switch 2 (2) through the free milling (3) into the groove until this switches.
3. Clamp the magnetic switch in this position in the groove by tightening the set-screw.
4. Open the gripper and close it again in order to test its functioning.

**Part gripped (I.D. gripping):**

1. Clamp the part to be gripped.
2. Push magnetic switch 1 (1) through the free milling (3) into the groove until this switches.
3. Clamp the magnetic switch (1) in the groove in this position by tightening the set-screw.
4. Close the gripper and open it again in order to check its function.

## 5 Troubleshooting

### 5.1 Product does not move?

Possible cause	Corrective action
Base jaws jam in housing, e.g. mounting surface is not sufficiently even.	Check the evenness of the mounting surface. ▶ 4.2.1 [ 19] Loosen the mounting screws of the product and actuate the product again.
Pressure drops below minimum.	Check air supply. ▶ 4.2.2 [ 20]
Compressed air lines switched.	Check compressed air lines.
Proximity switch defective or set incorrect.	Readjust or change sensor.
Unused air connections open.	Close unused air connections.
Component part defective.	Replace component or send it to SCHUNK for repair.

### 5.2 Product does not execute a complete stroke?

Possible cause	Corrective action
Dirt deposits between cover and piston.	Remove the cover, clean the product and regrease it. ▶ 6 [ 29]
Dirt deposits between basic jaws and guidance.	Disassemble and clean the product.
Pressure drops below minimum.	Check air supply. ▶ 4.2.2 [ 20]
Mounting surface is not sufficiently flat.	Check the evenness of the mounting surface. ▶ 4.2.1 [ 19]
Component part defective.	Send product with a SCHUNK repair order or dismantle product.
When fastening the product from the side, the maximum permissible depth of engagement was exceeded.	Use suitable fastening screws. ▶ 4.2.1 [ 19]

### 5.3 Product opens or closes jerkily?

Possible cause	Corrective action
Too little grease in the mechanical guiding areas.	Clean and lubricate product. ▶ 6 [ 29]
Compressed air lines blocked.	Check compressed air lines of damage.
Mounting surface is not sufficiently flat.	Check the evenness of the mounting surface.

## 5.4 Gripping force gets weaker

Possible cause	Corrective action
Compressed air can escape.	Check seals, if necessary, disassemble the product and replace seals.
Too much grease in the mechanical movement space.	Clean and lubricate product.
Pressure drops below minimum.	Check air supply. ▶ 3 [17]
Component part defective.	Replace component or send it to SCHUNK for repair.

## 5.5 Opening and closing times are not attained?

Possible cause	Corrective action
Compressed air lines are not installed optimally.	<p>If present: Open the flow control couplings on the product to the maximum that the movement of the jaws occurs without bouncing and hitting.</p> <p>Check compressed air lines.</p> <p>Inner diameters of compressed air lines are of sufficient size in relation to compressed air consumption.</p> <p>Keep compressed air lines between the product and directional control valve as short as possible.</p> <p>Flow rate of valve is sufficiently large relative to the compressed air consumption.</p> <p>If you still cannot achieve the open and close times in the latest catalog, we recommend the use of quick-air-vent-valves directly at the product.</p>

## 6 Maintenance

### 6.1 Notes



#### ⚠ WARNING

##### **Risk of injury from electric shock due to contact with live parts!**

- Before starting any work: Disconnect the power supply from the mains and secure against accidental switch-on.
- Work may only be performed by appropriately qualified personnel.

##### **Original spare parts**

Only use original SCHUNK spare parts when replacing wearing parts / spare parts.

### 6.2 Maintenance and lubrication intervals

#### NOTICE

##### **Material damage due to hardened lubricants!**

Lubricants harden more quickly at temperatures above 60 °C, leading to possible product damage.

- Reduce maintenance interval accordingly.

<b>Size</b>	<b>150 – 300</b>
Interval [Mio. cycles]	1.5

### 6.3 Lubricants/greasing areas (basic lubrication)

During maintenance, treat all greasing areas with lubricant. Apply a thin film of lubricant using a lint-free cloth. SCHUNK recommends the listed lubricants.

Lubricant point	Lubricant
Metallic sliding surfaces	SCHUNK grease 3
Seals and sealing surfaces	SCHUNK grease 1
Cylinder surfaces	SCHUNK grease 1

Details regarding SCHUNK lubricant designations are available at [schunk.com/lubricants](https://www.schunk.com/lubricants).

The product contains food-compliant lubricants as standard. **The requirements of standard EN 1672-2:2020 are not fully met.**

---

**NOTE**

- Change contaminated food-compliant lubricant.
  - Observe information in the safety data sheet from the lubricant manufacturer.
- 

**6.4 Disassembling the product**

Position of the item numbers ► 6.6 [ 33]

1. Move the gripper to the "open" position.
2. Remove the compressed air lines.
3. Loosen the set-screws (29) to reduce initial tension of the roller belt covering (20).
4. Unfasten and remove the screws (37 and 63).
5. Remove the upper cover plates (72 and 73).

**⚠ CAUTION**

**Roller belt covering (20) might still be under tension!**

Carefully remove the screws (64) of the cover plate (71).

---

6. Unfasten and remove the screws (64).
7. Remove the cover plate (71).
8. Unfasten and remove the fitting screws (31).
9. Remove the roller belt covering (20).
10. Unfasten the screws (62).
11. Remove the housing cover (6).

---

**NOTE**

**The base jaws (3) and guide strips (4 and 14) are specifically designed for the gripper and must not be interchanged during assembly.**

---

12. Mark the installation position of the base jaws.

**NOTICE**

**Never remove the guide strips (4 and 15) and the gear racks (11) from the base jaws (3) or the gripper housing (1)!**

---



---

**NOTE**

**Both base jaws are moved synchronously via the pinion or gear rack teeth.**

---

13. Push out the base jaw completely (including piston rod, piston...).

14. Pull out the piston rods (7).
15. Remove the safety ring (55).
16. Remove the cover (13).
17. Push the piston (12) out of the base jaw (3).

## 6.5 Servicing and assembling the product

Position of the item numbers ▶ 6.6 [ 33]

### Maintenance

- Clean all parts thoroughly and check for damage and wear.
- Treat all greased areas with lubricant.  
▶ 6.3 [ 29]
- Oil or grease bare external steel parts.
- Lightly grease all moving parts of the cover.
- Replace all wear parts / seals.
  - Position of the wearing parts ▶ 6.6 [ 33]
  - Seal kit ▶ 1.4.2 [ 8]

### Assembly

Assembly takes place in the opposite order to disassembly.  
Observe the following:

Position of the item numbers ▶ 6.6 [ 33]

- Observe the installation position of the base jaws.
- Setting the pre-tension of the roller belt cover (20):
  - Move the gripper to the "open" position.
  - Screw the fitting screw (31) into the axle of the roller hinge cover.
  - Turn the roller conveyor cover clockwise ▶ 6.5.2 [ 32].
  - Clamp the roller hinge axle with the grub screw (29) to maintain the pre-tension in the open state.
- Unless otherwise specified, secure all screws and nuts with Loctite no. 243 and tighten with the appropriate tightening torque. ▶ 6.5.1 [ 32]

### 6.5.1 Tightening torque for screws

Position of the item numbers ▶ 6.6 [📄 33]

Item	Tightening torque [Nm]
29, 31	6 Nm
33	5 Nm
37, 64	3 Nm
62	15 Nm

### 6.5.2 Revolutions of the fitting screw

Item	PFH	150	200	250	300
31	Number of revolutions	3	2 1/2	2	1 1/2

## 6.6 Assembly drawing

The following illustration is an example.

It is used as an illustration and for a classification of the individual components.

Deviations possible depending on size and version.

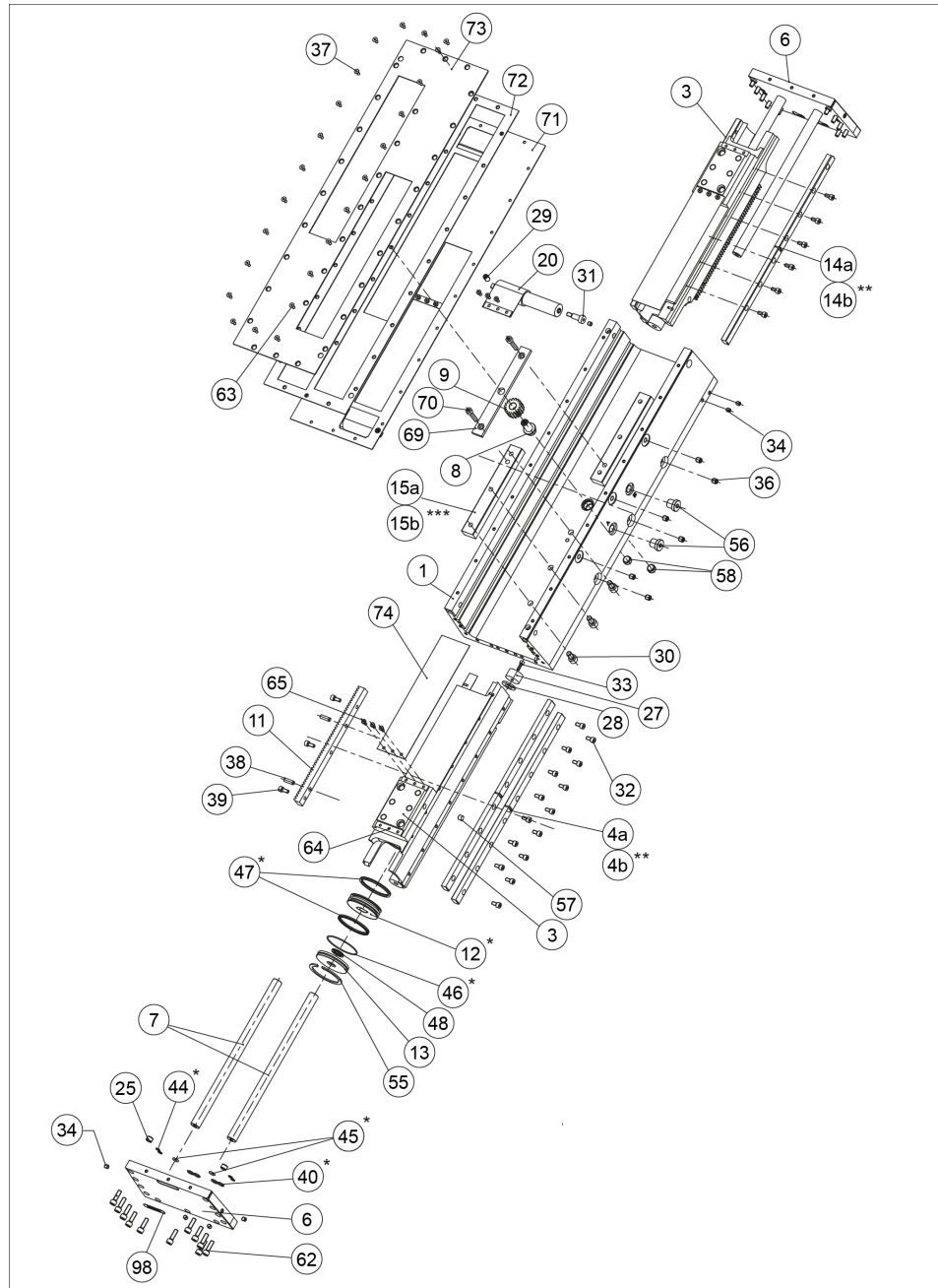

\* Wearing part, replace during maintenance., Included in the seal kit. Seal kit can only be ordered completely.

\*\* PFH 150/PFH 300 only

\*\*\* PFH 300 only

## 7 Translation of the original declaration of incorporation

in terms of the Directive 2006/42/EG, Annex II, Part 1 Section B.

Manufacturer/  
Distributor                      SCHUNK SE & Co. KG  
Spanntechnik | Greiftechnik | Automatisierungstechnik  
Bahnhofstr. 106 – 134  
D-74348 Lauffen/Neckar

We hereby declare that the partly completed machine described below

Product designation:        2-finger parallel gripper / PFH 150– 300/pneumatic  
ID number                      0302000, 0302020, 0302005, 0302010

meets the following basic occupational health and safety of the Machinery Directive 2006/42/EC:

No. 1.1.1, No. 1.1.2, No. 1.1.3, No. 1.1.5, No. 1.3.2, No. 1.5.3, No. 1.5.4, No. 1.5.6, No. 1.5.8, No. 1.5.10, No. 1.5.11, No. 1.5.13

The partly completed machinery may not be put into operation until it has been confirmed that the machine into which the partly completed machinery is to be installed complies with the provisions of the Machinery Directive (2006/42/EC). The declaration shall be rendered invalid if modifications are made to the product.

Applied harmonized standards, especially:

EN ISO 12100:2010              Safety of machinery – General principles for design –  
Risk assessment and risk reduction

The special technical documentation according to Annex VII, Part B, belonging to the partly completed machine, has been created.

Person authorized to compile the technical documentation:  
Stefanie Walter Address: refer to manufacturer's address

*Signature: see original declaration*

Lauffen/Neckar, March 2024

Dr.-Ing. Manuel Baumeister,  
Head of Systems Engineering,  
Technology & Innovation



## 9 Information on the RoHS Directive, REACH Regulation and Substances of Very High Concern (SVHC)

### RoHS Directive

SCHUNK products are classified as "large-scale stationary installations" or as "large-scale stationary industrial tools" within the meaning of Directive 2011/65/EU and its extension 2015/863/EU "on the restriction of the use of certain hazardous substances in electrical and electronic equipment (RoHS)", or fulfill their intended function only as part of one. Therefore products from SCHUNK do not fall within the scope of the directive at this time.

### REACH Regulation

Products from SCHUNK fully comply with the regulations of Regulation (EC) No. 1907/2006 "concerning the Registration, Evaluation, Authorization and Restriction of Chemicals (REACH)" and its amendment 2022/477. SCHUNK attaches great importance to completely avoiding chemicals of concern to humans and the environment wherever possible.

Only in rare exceptional cases do SCHUNK products contain SVHC substances on the candidate list with a mass content above 0.1%. In accordance with Article. 33 (1) of Regulation (EC) No. 1907/2006, SCHUNK complies with its duty to "communicate information on substances in articles" and lists the components concerned and the substances used in an overview that can be viewed at [schunk.com\SVHC](https://www.schunk.com/SVHC).

*Signature: see original declaration*

Lauffen/Neckar, March 2024

Dr.-Ing. Manuel Baumeister,  
Head of Systems Engineering,  
Technology & Innovation

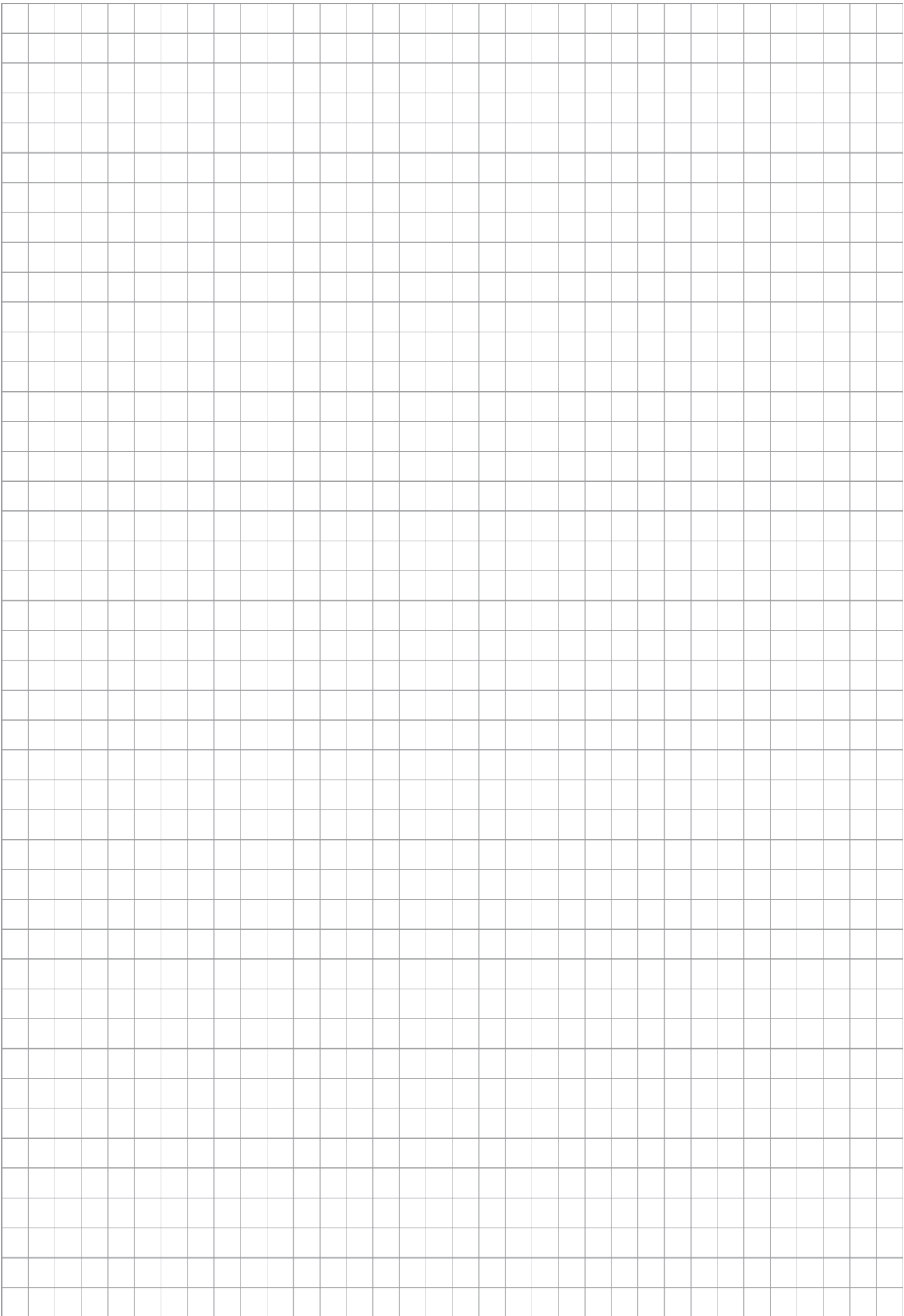

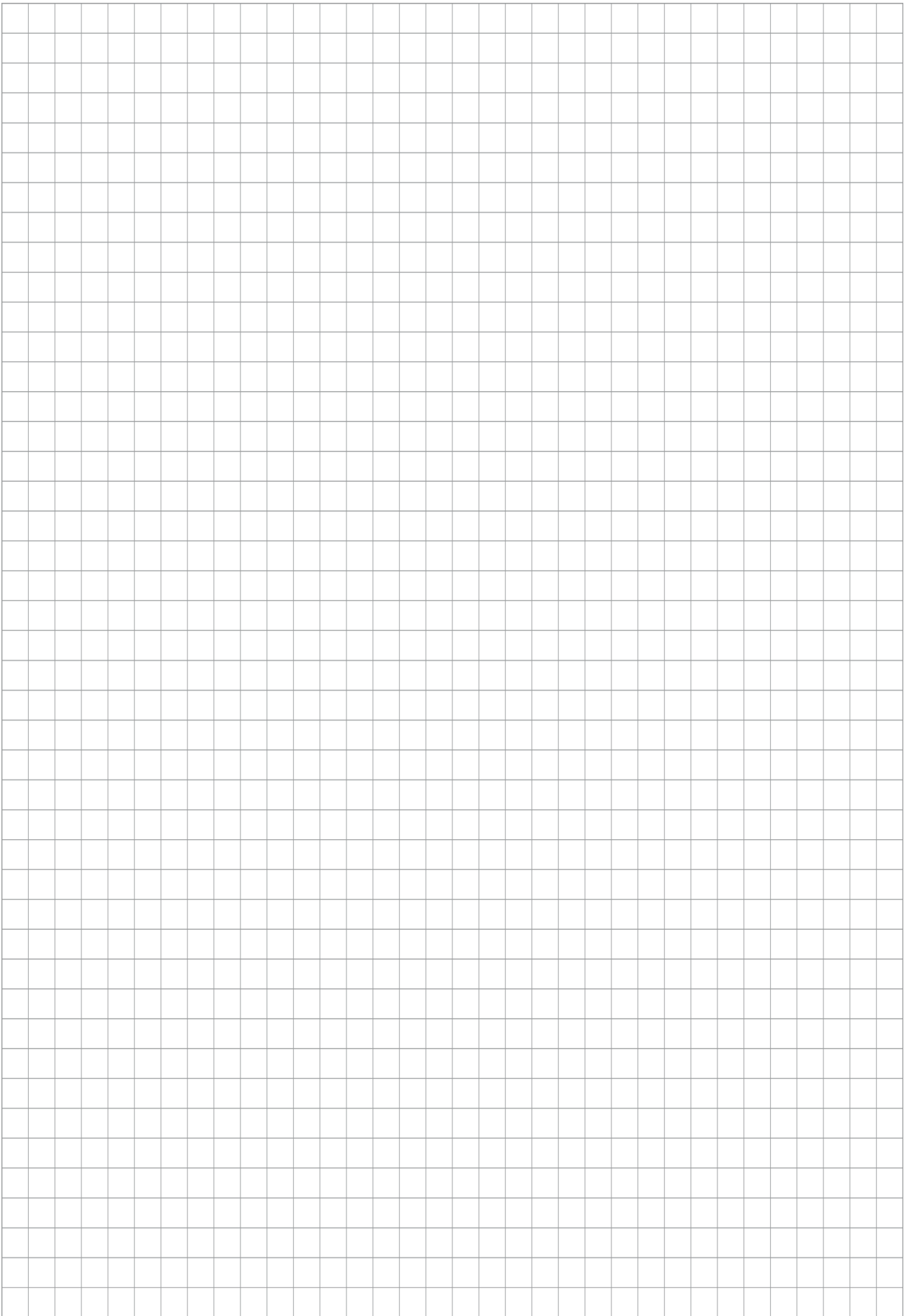





**SCHUNK SE & Co. KG**  
Spanntechnik | Greiftechnik | Automatisierungstechnik

Bahnhofstr. 106 - 134  
D-74348 Lauffen/Neckar  
Tel. +49-7133-103-0  
info@de.schunk.com  
schunk.com

Folgen Sie uns | *Follow us*



Wir drucken nachhaltig | *We print sustainable*