



Assembly and Operating Manual

PGN

2-Finger Parallel Gripper

Translation of the original manual

Hand in hand for tomorrow

Imprint

Copyright:

This manual is protected by copyright. The author is SCHUNK GmbH & Co. KG. All rights reserved.

Technical changes:

We reserve the right to make alterations for the purpose of technical improvement.

Document number: 389286

Version: 13.00 | 01/03/2023 | en

Dear Customer,

Thank you for trusting our products and our family-owned company, the leading technology supplier of robots and production machines.

Our team is always available to answer any questions on this product and other solutions. Ask us questions and challenge us. We will find a solution!

Best regards,

Your SCHUNK team

Customer Management

Tel. +49-7133-103-2503

Fax +49-7133-103-2189

cmg@de.schunk.com



Please read the operating manual in full and keep it close to the product.

Table of Contents

1 General	5
1.1 About this manual.....	5
1.1.1 Presentation of Warning Labels	5
1.1.2 Applicable documents	6
1.1.3 Sizes.....	6
1.1.4 Variants	6
1.2 Warranty	6
1.3 Scope of delivery.....	7
1.4 Accessories	7
1.4.1 Seal kits	7
1.4.2 Spare parts packages	8
2 Basic safety notes	9
2.1 Intended use.....	9
2.2 Not intended use	9
2.3 Constructional changes.....	9
2.4 Spare parts	9
2.5 Gripper fingers	10
2.6 Ambient conditions and operating conditions	10
2.7 Personnel qualification	10
2.8 Personal protective equipment	11
2.9 Notes on safe operation.....	11
2.10 Transport.....	12
2.11 Malfunctions.....	12
2.12 Disposal	12
2.13 Fundamental dangers	12
2.13.1 Protection during handling and assembly	13
2.13.2 Protection during commissioning and operation	13
2.13.3 Protection against dangerous movements	13
2.13.4 Protection against electric shock.....	14
2.14 Notes on particular risks	15
3 Technical Data	17
4 Assembly.....	18
4.1 Connections	18
4.1.1 Mechanical connection.....	18
4.1.2 Air connection	19

4.2	Sensors	21
4.2.1	Overview of sensors	21
4.2.2	Inductive proximity switch IN 80	21
4.2.3	Flexible position sensor FPS	25
4.2.4	Inductive proximity switch IN 40	25
4.2.5	Inductive proximity switch IN 60	27
4.2.6	Operation with a closing and opening proximity switch.....	29
5	Troubleshooting.....	31
5.1	Product does not move?	31
5.2	Product does not travel the entire stroke.....	31
5.3	Product is opening or closing abruptly	31
5.4	Gripping force is dropping.....	31
5.5	Product does not achieve the opening and closing times	32
6	Maintenance	33
6.1	Notes.....	33
6.2	Maintenance interval.....	33
6.3	Lubricants/Lubrication points.....	33
6.4	Disassemble the product.....	34
6.4.1	Version without gripping force maintenance	34
6.4.2	Version with gripping force maintenance O.D.	34
6.4.3	Version with gripping force maintenance I.D.....	35
6.5	Servicing and assembling the module.....	36
6.5.1	Assembly device.....	37
6.5.2	Screw tightening torques	40
6.6	Assembly drawing	41
7	Translation of the original declaration of incorporation	42
8	UKCA declaration of incorporation	43
9	Annex to declaration of Incorporation	44

1 General

1.1 About this manual

This manual contains important information for a safe and appropriate use of the product.

This manual is an integral part of the product and must be kept accessible for the personnel at all times.

Before starting work, the personnel must have read and understood this operating manual. Prerequisite for safe working is the observance of all safety instructions in this manual.

In addition to these instructions, the documents listed under ▶ 1.1.2 [6] are applicable.

NOTE: The illustrations in this manual are intended to provide a basic understanding and may deviate from the actual version.

1.1.1 Presentation of Warning Labels

To make risks clear, the following signal words and symbols are used for safety notes.



⚠ DANGER

Dangers for persons!

Non-observance will inevitably cause irreversible injury or death.



⚠ WARNING

Dangers for persons!

Non-observance can lead to irreversible injury and even death.



⚠ CAUTION

Dangers for persons!

Non-observance can cause minor injuries.

NOTICE

Material damage!

Information about avoiding material damage.

1.1.2 Applicable documents

- General terms of business *
- Catalog data sheet of the purchased product *
- Assembly and operating manuals of the accessories *

The documents labeled with an asterisk (*) can be downloaded from [schunk.com](https://www.schunk.com).

1.1.3 Sizes

This operating manual applies to the following sizes:

- PGN 50
- PGN 64
- PGN 80
- PGN 100
- PGN 125
- PGN 160
- PGN 200
- PGN 300
- PGN 380

1.1.4 Variants

This operating manual applies to the following variations:

- PGN stroke 1
- PGN stroke 2
- PGN with gripping force maintenance "O.D. gripping" (AS)
- PGN with gripping force maintenance "I.D. gripping" (IS)
- PGN high-temperature (V/HT)
- PGN dust-tight (SD)

1.2 Warranty

If the product is used as intended, the warranty is valid for 24 months from the ex-works delivery date under the following conditions:

- Observe the specified maintenance and lubrication intervals
- Observe the ambient conditions and operating conditions

Parts touching the workpiece and wear parts are not included in the warranty.

1.3 Scope of delivery

The scope of delivery includes

- 2-Finger Parallel Gripper PGN in the version ordered
- Accessory pack

Content of the accessory pack:

- 2x O-ring for hose-free direct connection
- 1x Switching cam (PGN 100, 125, 160)
- 2x clamping sleeve (PGN 200, 300)
- 2x Cylindrical pin
- 2x Locking screw

ID.-No. of the accessory pack

Size	ID number	
	PGN	PGNV/HT
PGN 100	5509375	395509375
PGN 125	5509378	395509378
PGN 160	5509379	395509379
PGN 200	5510114	395510114
PGN 300	5510608	395510608

1.4 Accessories

A wide range of accessories are available for this product

For information regarding which accessory articles can be used with the corresponding product variants, see catalog data sheet.

1.4.1 Seal kits

Size	ID number	
	PGN	PGN V/HT
PGN 50	0370749	30012207
PGN 64	0370500	0370748
PGN 80	0370501	0370725
PGN 100	0370502	0370737
PGN 125	0370503	0370652
PGN 160	0370504	0370622
PGN 200	0370496	0370857
PGN 300	0370796	0370848
PGN 380	5516411	0370927

1.4.2 Spare parts packages

Spare parts packages allow for the maintenance and repair of individual components. For information on the range of the spare parts packages, see www.schunk.com > Service.

The following spare parts packages are available for this product:

- Spring spare parts package
- Control cam spare parts package
- Spare part package "Sealing kit"

Size	Spare part kit for		
	"Spring"	"Switching cam"	"Seal kit"
PGN 50	1309013 (IS/-AS)	-	1310017
PGN 64	1309951 (AS) 1309985 (IS)	1310004	1310019
PGN 80	1309986 (AS) 1309989 (IS)	1310007	1310020
PGN 100	1309990 (AS) 1309991 (IS)	1310008	1310024
PGN 125	1309992 (AS) 1309993 (IS)	1310009	1310027
PGN 160	1309995 (AS) 1309997 (IS)	1310010	1310029
PGN 200	1309998 (AS) 1309999 (IS)	1310013	1310031
PGN 300	1310001 (IS/-AS)	1310014	1310033
PGN 380	1310002 (AS) 1310003 (IS)	1310015	1310034

Tab.: ID. No. spare part kit

2 Basic safety notes

2.1 Intended use

The product is designed exclusively for gripping and temporarily holding workpieces or objects.

- The product may only be used within the scope of its technical data, ▶ 3 [17].
- The product is intended for installation in a machine/ automated system. The applicable guidelines for the machine/ automated system must be observed and complied with.
- The product is intended for industrial and industry-oriented use. Its use outside enclosed spaces is only permitted if suitable protective measures are taken against outdoor exposure. The product is not suitable for use in salty air.
- The product can be used within the permissible load limits and technical data for holding workpieces during simple machining operations, but is not a clamping device according to EN 1550:1997+A1:2008.
- Appropriate use of the product includes compliance with all instructions in this manual.
- Any utilization that exceeds or differs from the appropriate use is regarded as misuse.

2.2 Not intended use

It is not intended use if the product is used, for example, as a pressing tool, stamping tool, lifting gear, guide for tools, cutting tool, clamping device or a drilling tool.

- Any utilization that exceeds or differs from the appropriate use is regarded as misuse.

2.3 Constructional changes

Implementation of structural changes

By conversions, changes, and reworking, e.g. additional threads, holes, or safety devices can impair the functioning or safety of the product or damage it.

- Structural changes should only be made with the written approval of SCHUNK.

2.4 Spare parts

Use of unauthorized spare parts

Using unauthorized spare parts can endanger personnel and damage the product or cause it to malfunction.

- Use only original spare parts or spares authorized by SCHUNK.

2.5 Gripper fingers

Requirements of gripper fingers

Accumulated energy can make the product unsafe and risk the danger of serious injuries and considerable material damage.

- Execute the gripper fingers in such a way that the product reaches either the "open" or "closed" position in a de-energized state.
- Only change gripper fingers if no residual energy can be released.
- Make sure that the product and the top jaws are a sufficient size for the application.

2.6 Ambient conditions and operating conditions

Required ambient conditions and operating conditions

Incorrect ambient and operating conditions can make the product unsafe, leading to the risk of serious injuries, considerable material damage and/or a significant reduction to the product's life span.

- Make sure that the product is used only in the context of its defined application parameters, ▶ 3 [📄 17].

2.7 Personnel qualification

Inadequate qualifications of the personnel

If the personnel working with the product is not sufficiently qualified, the result may be serious injuries and significant property damage.

- All work may only be performed by qualified personnel.
- Before working with the product, the personnel must have read and understood the complete assembly and operating manual.
- Observe the national safety regulations and rules and general safety instructions.

The following personal qualifications are necessary for the various activities related to the product:

Trained electrician

Due to their technical training, knowledge and experience, trained electricians are able to work on electrical systems, recognize and avoid possible dangers and know the relevant standards and regulations.

Qualified personnel	Due to its technical training, knowledge and experience, qualified personnel is able to perform the delegated tasks, recognize and avoid possible dangers and knows the relevant standards and regulations.
Instructed person	Instructed persons were instructed by the operator about the delegated tasks and possible dangers due to improper behaviour.
Service personnel of the manufacturer	Due to its technical training, knowledge and experience, service personnel of the manufacturer is able to perform the delegated tasks and to recognize and avoid possible dangers.

2.8 Personal protective equipment

Use of personal protective equipment

Personal protective equipment serves to protect staff against danger which may interfere with their health or safety at work.

- When working on and with the product, observe the occupational health and safety regulations and wear the required personal protective equipment.
- Observe the valid safety and accident prevention regulations.
- Wear protective gloves to guard against sharp edges and corners or rough surfaces.
- Wear heat-resistant protective gloves when handling hot surfaces.
- Wear protective gloves and safety goggles when handling hazardous substances.
- Wear close-fitting protective clothing and also wear long hair in a hairnet when dealing with moving components.

2.9 Notes on safe operation

Incorrect handling of the personnel

Incorrect handling and assembly may impair the product's safety and cause serious injuries and considerable material damage.

- Avoid any manner of working that may interfere with the function and operational safety of the product.
- Use the product as intended.
- Observe the safety notes and assembly instructions.
- Do not expose the product to any corrosive media. This does not apply to products that are designed for special environments.
- Eliminate any malfunction immediately.
- Observe the care and maintenance instructions.

- Observe the current safety, accident prevention and environmental protection regulations regarding the product's application field.

2.10 Transport

Handling during transport

Incorrect handling during transport may impair the product's safety and cause serious injuries and considerable material damage.

- When handling heavy weights, use lifting equipment to lift the product and transport it by appropriate means.
- Secure the product against falling during transportation and handling.
- Stand clear of suspended loads.

2.11 Malfunctions

Behavior in case of malfunctions

- Immediately remove the product from operation and report the malfunction to the responsible departments/persons.
- Order appropriately trained personnel to rectify the malfunction.
- Do not recommission the product until the malfunction has been rectified.
- Test the product after a malfunction to establish whether it still functions properly and no increased risks have arisen.

2.12 Disposal

Handling of disposal

The incorrect handling of disposal may impair the product's safety and cause serious injuries as well as considerable material and environmental harm.

- Follow local regulations on dispatching product components for recycling or proper disposal.

2.13 Fundamental dangers

General

- Observe safety distances.
- Never deactivate safety devices.
- Before commissioning the product, take appropriate protective measures to secure the danger zone.

- Disconnect power sources before installation, modification, maintenance, or calibration. Ensure that no residual energy remains in the system.
- If the energy supply is connected, do not move any parts by hand.
- Do not reach into the open mechanism or movement area of the product during operation.

2.13.1 Protection during handling and assembly

Incorrect handling and assembly

Incorrect handling and assembly may impair the product's safety and cause serious injuries and considerable material damage.

- Have all work carried out by appropriately qualified personnel.
- For all work, secure the product against accidental operation.
- Observe the relevant accident prevention rules.
- Use suitable assembly and transport equipment and take precautions to prevent jamming and crushing.

Incorrect lifting of loads

Falling loads may cause serious injuries and even death.

- Stand clear of suspended loads and do not step into their swiveling range.
- Never move loads without supervision.
- Do not leave suspended loads unattended.

2.13.2 Protection during commissioning and operation

Falling or violently ejected components

Falling and violently ejected components can cause serious injuries and even death.

- Take appropriate protective measures to secure the danger zone.
- Never step into the danger zone during operation.

2.13.3 Protection against dangerous movements

Unexpected movements

Residual energy in the system may cause serious injuries while working with the product.

- Switch off the energy supply, ensure that no residual energy remains and secure against inadvertent reactivation.
- Never rely solely on the response of the monitoring function to avert danger. Until the installed monitors become effective, it must be assumed that the drive movement is faulty, with its

action being dependent on the control unit and the current operating condition of the drive. Perform maintenance work, modifications, and attachments outside the danger zone defined by the movement range.

- To avoid accidents and/or material damage, human access to the movement range of the machine must be restricted. Limit/prevent accidental access for people in this area due through technical safety measures. The protective cover and protective fence must be rigid enough to withstand the maximum possible movement energy. EMERGENCY STOP switches must be easily and quickly accessible. Before starting up the machine or automated system, check that the EMERGENCY STOP system is working. Prevent operation of the machine if this protective equipment does not function correctly.

2.13.4 Protection against electric shock

Possible electrostatic energy

Components or assembly groups may become electrostatically charged. When the electrostatic charge is touched, the discharge may trigger a shock reaction leading to injuries.

- The operator must ensure that all components and assembly groups are included in the local potential equalisation in accordance with the applicable regulations.
- While paying attention to the actual conditions of the working environment, the potential equalisation must be implemented by a specialist electrician according to the applicable regulations.
- The effectiveness of the potential equalisation must be verified by executing regular safety measurements.

2.14 Notes on particular risks



⚠ DANGER

Risk of fatal injury from suspended loads!

Falling loads can cause serious injuries and even death.

- Stand clear of suspended loads and do not step within their swiveling range.
- Never move loads without supervision.
- Do not leave suspended loads unattended.
- Wear suitable protective equipment.



⚠ WARNING

Risk of injury from objects falling and being ejected!

Falling and ejected objects during operation can lead to serious injury or death.

- Take appropriate protective measures to secure the danger zone.



⚠ WARNING

Risk of injury due to unexpected movements!

If the power supply is switched on or residual energy remains in the system, components can move unexpectedly and cause serious injuries.

- Before starting any work on the product: Switch off the power supply and secure against restarting.
- Make sure, that no residual energy remains in the system.



⚠ WARNING

Risk of injury from crushing and impacts!

Serious injury could occur during movement of the base jaw, due to breakage or loosening of the gripper fingers or if the workpiece is lost.

- Wear suitable protective equipment.
- Do not reach into the open mechanism or the movement area of the product.



⚠ WARNING

Risk of injury from sharp edges and corners!

Sharp edges and corners can cause cuts.

- Use suitable protective equipment.



⚠ WARNING

Risk of injury due to spring forces!

Parts are under spring tension on products which clamp using spring force or which have gripping force maintenance. While disassembling components can move unexpectedly and cause serious injuries.

- Disassemble the product cautiously.
- Make sure that no residual energy remains in the system.



⚠ WARNING

Risk of injury from objects falling during energy supply failure

Products with a mechanical gripping force maintenance can, during energy supply failure, still move independently in the direction specified by the mechanical gripping force maintenance.

- Secure the end positions of the product with SCHUNK SDV-P pressure maintenance valves.

3 Technical Data

Designation	PGN
Pressure medium	Compressed air, compressed air quality according to ISO 8573-1:7 4 4
Nominal working pressure [bar]	6
Min. pressure [bar]	
without gripping force	2.0
maintenance	4.0
with gripping force maintenance	
Max. pressure [bar]	
without gripping force	8.0
maintenance	6.5
with gripping force maintenance	

Ambient conditions and operating conditions

Designation	PGN
Ambient temperature [°C]	
min.	-10
max.	+90
Protection class IP *	40
Noise emission [dB(A)]	≤ 70

* For use in dirty ambient conditions (e.g. sprayed water, vapors, abrasion or processing dust) SCHUNK offers corresponding product options as standard. SCHUNK also offers customized solutions for special applications in dirty ambient conditions.

More technical data is included in the catalog data sheet. Whichever is the latest version.

4 Assembly

4.1 Connections

4.1.1 Mechanical connection



⚠ WARNING

Risk of injury due to unexpected movements!

If the power supply is switched on or residual energy remains in the system, components can move unexpectedly and cause serious injuries.

- Before starting any work on the product: Switch off the power supply and secure against restarting.
- Make sure, that no residual energy remains in the system.

Evenness of the mounting surface

The values apply to the whole mounting surface to which the product is mounted.

Edge length	Permissible unevenness
< 100	< 0.02
> 100	< 0.05

Tab.: Requirements for evenness of the mounting surface (Dimensions in mm)

Mounting

The product can be mounted from three sides.

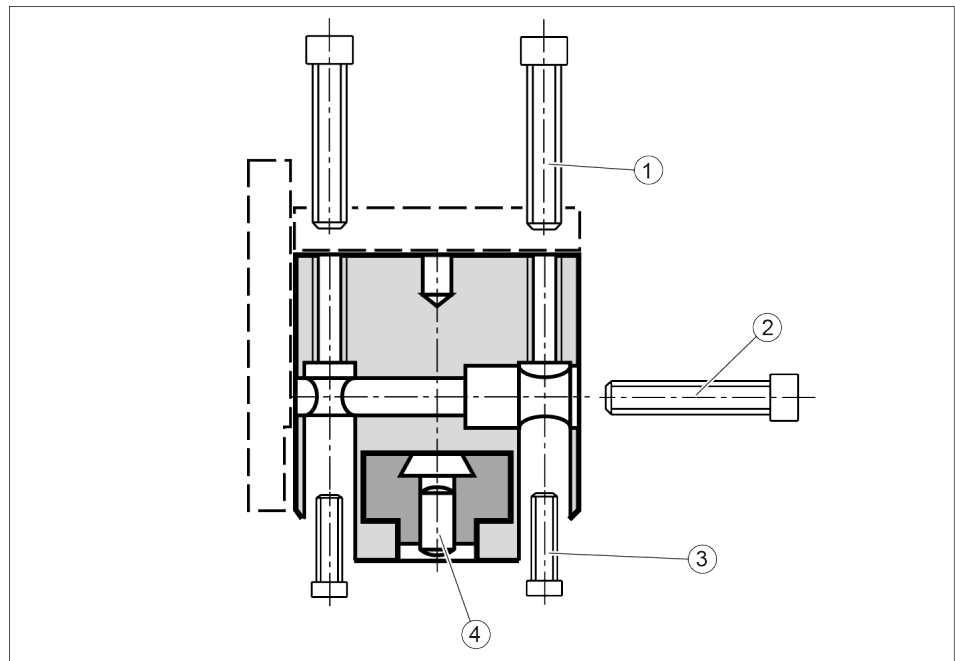

Assembly options

1	Mounting from the rear	3	Mounting from the front
2	Side mounting	4	Cylindrical pin

Maximal screw-in depth of the fastening screws provided by the customer.

Tab.: Mounting material

Item	PGN								
	50	64	80	100	125	160	200	300	380
1	4 x M4	4 x M5	4 x M5	4 x M6	4 x M8	4 x M8	4 x M10	4 x M16	4 x M20
2	2 x M3	2 x M4	2 x M5	2 x M6	2 x M8	2 x M8	2 x M10	2 x M12	2 x M16
3	4 x M3 x 25	4 x M4 x 16	4 x M4 x 20	4 x M5 x 25	4 x M6 x 30	4 x M6 x 30	4 x M8 x 40	4 x M12 x 55	4 x M16 x 76
4	Ø3H7	Ø4H7	Ø4H7	Ø5H7	Ø6H7	Ø6H7	Ø8H7	Ø10H7	Ø10H7

NOTE

- For mounting from the rear or side fix the module on the pre-posed fixing bores.
- Mount the module using the mounting bores.
- Mount the top jaws using the mounting bores provided.
- In case of lateral fastening, the adapter plate must have an undercut above the fastening bores in order to avoid a jamming of the base jaws.

4.1.2 Air connection**NOTICE****Damage to the gripper is possible!**

If the maximum permissible finger weight or the permissible mass moment of inertia of the fingers is exceeded, the gripper can be damaged.

- A jaw movement always has to be without jerks and bounce.
- You must therefore implement sufficient reduction and/or damping.
- Observe the information in the catalog data sheet.

NOTE

- Observe the requirements for the compressed air supply, ▶ 3 [17].
- In case of compressed air loss (cutting off the energy line), the components lose their dynamic effects and do not remain in a secure position. However, the use of a SDV-P pressure maintenance valve is recommended in this case in order to maintain the dynamic effect for some time. Product variants

are also offered with mechanical gripping force via springs, which also ensure a minimum clamping force in the event of a pressure drop.

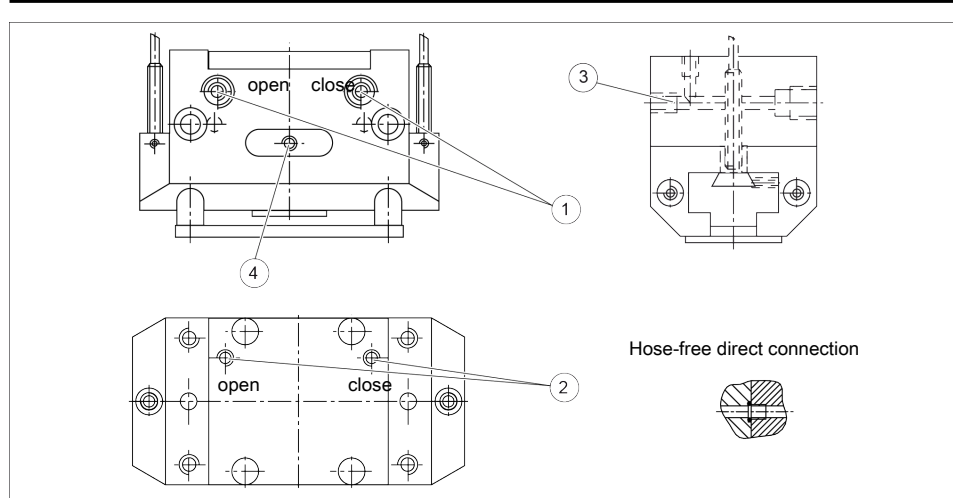

1 Main connections (Hose connection)
(A = open, B = close)

2 Hose-free direct connection at the base
(a = open, b = close)

3 Hose-free direct connection at the side
(a = open, b = close)

4 Air purge connection

- Open only the air connections that are needed.
- Close unused main air connections using the screw plugs from the enclosed pack.
- For a hose-free direction connection, use the O-rings from the enclosed pack.

4.2 Sensors

The product is prepared for the use of sensors of the type IN and FPS.

- If you require further information on sensor operation, contact your SCHUNK contact person or download information from our homepage.
- Technical data for the sensors can be found in the data sheets (included in the scope of delivery).

4.2.1 Overview of sensors

Designation	PGN									
	50	64	80	100	125	160	200	300	380	
Inductive proximity switch IN 80	X	X	–	–	X	X	X	X	X	
Flexible position sensor FPS	–	X	X	X	X	X	X	X	–	
Inductive proximity switch IN 40	X	–	–	–	–	–	–	–	–	
Inductive proximity switch IN 60	–	–	X	X	–	–	–	–	–	
Inductive proximity switch IN 120	–	–	–	–	–	–	X	X	–	

4.2.2 Inductive proximity switch IN 80

Assembly and adjustment of proximity switch PGN 64, 80, 100, 125 and 160

NOTE

Interrogation of the proximity switch for PGN 50 is done without control cams.

Gripper open:

1. Set the gripper onto "open" position.
2. Carefully push the closer into the bushing until the proximity switch contacts the control cam.
3. Draw back the proximity switch by appr. 0.5 mm.
4. Fasten the proximity switch with the set-screw (23).
In case of PGN 64 fasten the clamping screw at the bracket.
5. Connect the proximity switch.
6. Control the function by opening and closing the gripper.

NOTICE

The max. tightening torque for fastening screws of proximity switches is 100 Ncm.

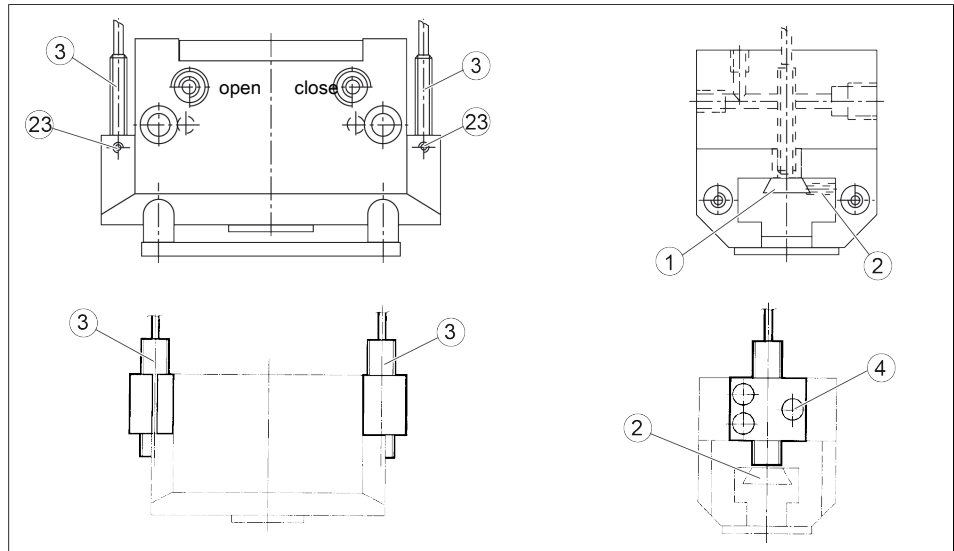

Gripper closed:

1. Set the gripper onto "closed" position.
2. Carefully push the closer into the bushing until the proximity switch contacts the control cam.
3. Draw back the proximity switch by appr. 0.5 mm.
4. Fasten the proximity switch with the set-screw (23).
In case of PGN 64 fasten the clamping screw at the bracket.
5. Connect the proximity switch.
6. Control the function by opening and closing the gripper.

Part gripped:

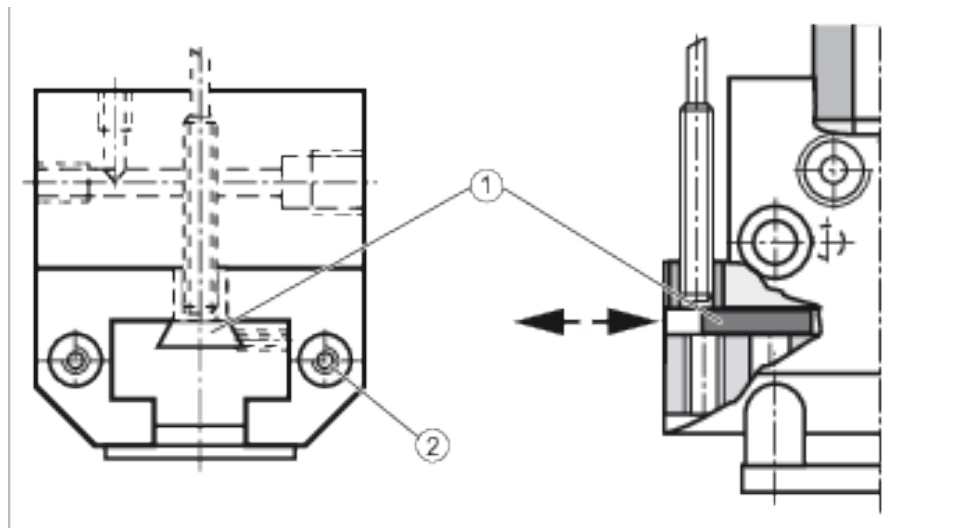

1. Mount the proximity switch as described before.
2. Set the gripper onto "open" position.
3. Loosen the set-screw (2) which clamps the control cam (1).
4. Clamp the component to be gripped.
5. Slide the control cam (1) which switches the proximity switch.

Assembly and adjustment of Proximity Switch PGN 200, 300 and 380

6. Carefully set the gripper onto "open" position.
7. Fasten the control cam (1) with the set-screw (2) and check the function.

NOTE

- For standard applications proximity switch M 8 x 1 x 32 is used.
- If proximity switches $\varnothing 12 \times 60$ are used, the bushing (item 68) has to be replaced by the one of (item 67) from the little plastic bag.
- Proximity switches are accessories and have to be ordered separately.
- The control cams may be adjusted so that additionally to the two positions gripper "open" and gripper "closed" every intermediate position may be monitored by sliding the control cam.

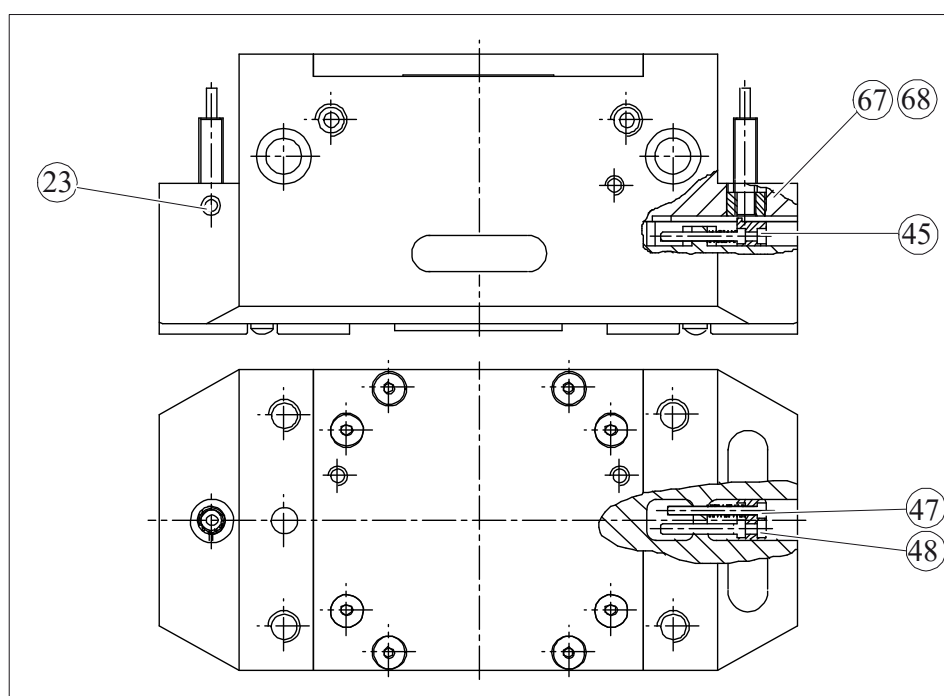

Gripper open:

1. Place the gripper onto "open" position.
2. Carefully slide the proximity switch into the bushing until the control cam (45) contacts the step.
3. If necessary, the control cam (45) and the screw (47) have to be adjusted by loosening the screw (48) first, and then adjust the control cam together with the screw (47) and clamp it together with the screw (48).
4. Draw back the proximity switch by appr. 0.5 mm.

5. Fasten the proximity switch with a set-screw (23).
6. Connect the proximity switch.
7. Check the function by opening and closing the gripper.
8. In order to adjust the gripper "open" position more precisely, it may be necessary to change the control cams position another time. Proceed the same way as described from step 3.

Gripper closed:

1. Please the gripper onto "Closed" position.
2. Carefully slide the proximity switch into the bushing until the control cam (45) contacts the step.
3. If necessary, the control cam (45) and the screw (47) have to be adjusted by loosening the screw (48) first, and then adjust the control cam together with the screw (47) and clamp it together with the screw (48).
4. Draw back the proximity switch by appr. 0.5 mm.
5. Fasten the proximity switch with a set-screw (23).
6. Connect the proximity switch.
7. Check the function by opening and closing the gripper.
8. In order to adjust the gripper "open" position more precisely, it may be necessary to change the control cams position another time. Proceed the same way as described from step 3.

Part gripped:

1. Place the gripper onto "open" position.
2. Loosen the screws (47 and 48) which clamp the control cam.
3. Clamp the component to be gripped.
4. Move the control cam by means of the screws (47 and 48) until the proximity switch is switching.
5. Fasten the control cam with screw (48).

NOTE

If the proximity switch should not switch, you will have to turn the control cam:

1. Loosen screw (47).
2. Remove control cam (45).
3. Insert the pressure spring together with the turned control cam.
4. Insert the screw (47) again and adjust the control cam.

4.2.3 Flexible position sensor FPS

In order to use the flexible position sensor FPS-S13, the gripper have to be prepared with a special mounting kit (size 64 – 300). At the gripper PGN 380, the FPS-S13 is inserted into a recess in the housing.

Mounting of the sensor

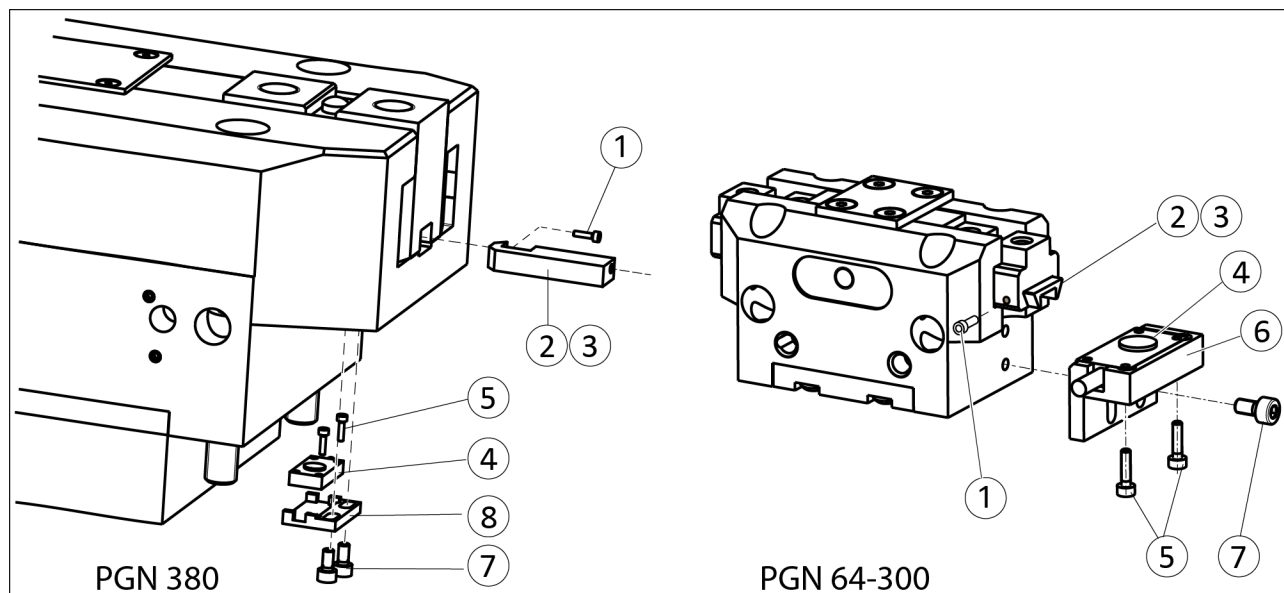

1. Set the gripper to the "open" position.
 2. Loose screw (1) and remove switch cam (2) from the base jaw.
 3. Push the switch cam (3) from the mounting kit into the base jaw and and fix it with the screw (1).
 4. Mount the Sensor FPS (4) with 2 screws (5) from the mounting kit at the bracket (6).
 5. **PGN 64-300:** Mount the bracket (6) with 1 screw (7) from the mounting kit to the gripper.
PGN 380: Mount the bracket (8) with 2 screws (7) from the mounting kit to the gripper.
- ⇒ For adjustment of the sensor, see the separate operating manual.

4.2.4 Inductive proximity switch IN 40

Mounting kit

To use the inductive sensor, the gripper has to be retrofitted with a special mounting kit. This mounting kit is available from SCHUNK for the models below.

Assembly and adjustment of Proximity Switch PGN 50

NOTE

Proximity switches are accessories and have to be ordered separately. The monitoring of the proximity switch $\varnothing 4 \times 25$ (1 closer and 1 opener) is adjustable. During the interrogation with proximity switches M8 x 1 x 32 only the position gripper "open" and gripper "closed" can be monitored.

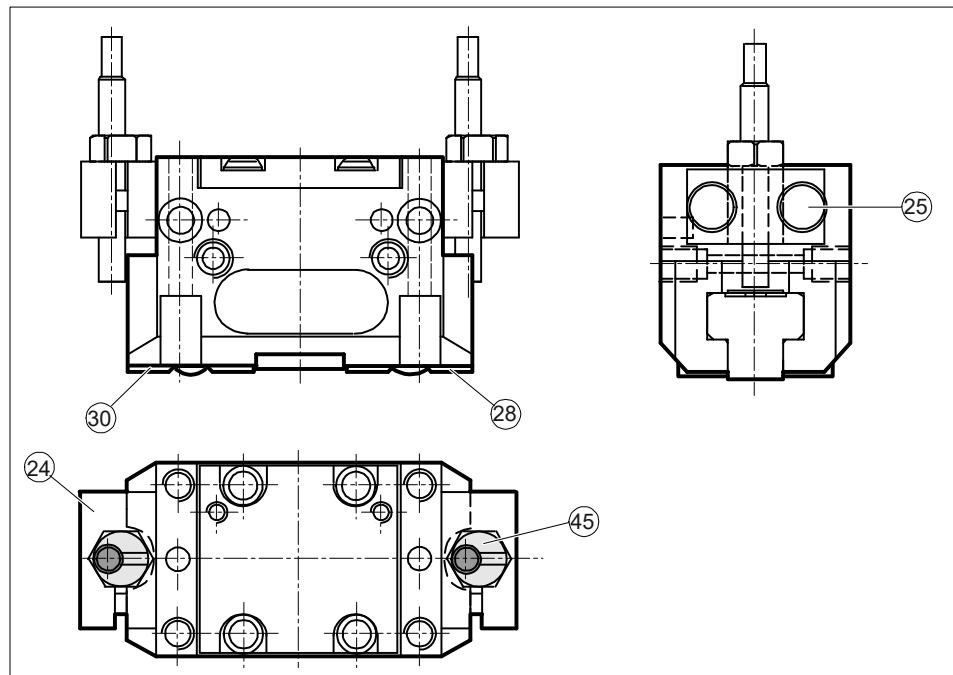

Gripper open:

1. Set the gripper onto "open" position.
2. Carefully slide the proximity switch 1 into the eccentric insert (45), until it contacts the base jaws with the milled step (30).
3. Draw back the proximity switch by appr. 0.5 mm.
4. Turn the eccentric insert (45) by means of a fork wrench SW 8, until the proximity switch switches.
5. Fasten the eccentric insert (45) with the clamping screw (25).
6. Control of function by closing and opening the gripper.

Gripper closed:

1. Set the gripper onto "closed" position.
2. Carefully move the proximity switch into the eccentric insert (45) until it contacts the base jaws with the milled step (28).
3. Draw back the proximity switch by appr. 0.5 mm.
4. Turn the eccentric insert (45) by means of a fork wrench SW 8, until the proximity switch switches.
5. Fasten the eccentric insert (45) with the clamping screw (25).
6. Control of function by closing and opening the gripper.

Part gripped:

1. Clamp the component to be gripped.
2. Carefully slide the proximity switch into the eccentric insert (45) until it contacts the base jaw (28/30).
3. Draw back the proximity switch by appr. 0.5 mm.
4. Turn the eccentric insert (45) by means of a fork wrench SW 8, until the proximity switch switches.
5. Fasten the eccentric insert (45) with the clamping screw (25).
6. Control of function by closing and opening the gripper.

For being able to monitor both end positions gripper "open" and gripper "closed" with 2 proximity switches M 8 x 1 x 32, the two eccentric inserts (item 45) have to be taken out of the clamping bracket (item 24) and have to be replaced by proximity switches. Herefore a "Closer" for position gripper "open" and an "Opener" for position gripper "closed" are necessary.

Moreover, the clamping bracket for position gripper "open" has to be equipped with a washer (Thickness $t = 2.5$ mm at stroke 1, or $t = 1.5$ mm at stroke 2); the clamping bracket for position gripper "closed" with a washer (Thickness $t = 1$ mm) and sometimes with longer screws.

The suitable washers and fastening screws are supplied in the little plastic bag. By varigating the switching distance, the switching time can be slightly adjusted.

4.2.5 Inductive proximity switch IN 60

Mounting kit

To use the inductive sensor, the gripper has to be retrofitted with a special mounting kit. This mounting kit is available from SCHUNK for the models below.

Assembly and adjustment of Proximity Switches PGN 80 and 100

NOTE

Proximity switches are accessories and have to be ordered separately. The control cams for gripper "open" and "closed" are mounted.

For gripper position "component gripped" a control cam is needed, which may be shortened for large interfering edges. This control cam is supplied free of charge in every consignment of this type of gripper.

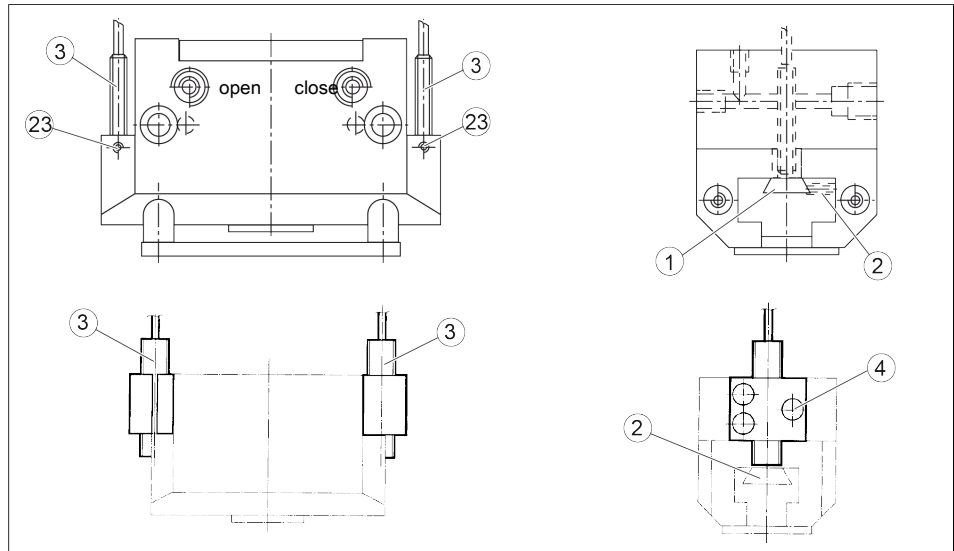

Gripper open:

1. Set the gripper onto "open" position.
2. Carefully push the closer into the bushing until the proximity switch contacts the control cam.
3. Draw back the proximity switch by appr. 0.5 mm.
4. Fasten the proximity switch with the set-screw (23). In case of PGN 64 fasten the clamping screw at the bracket.
5. Connect the proximity switch.
6. Control the function by opening and closing the gripper.

NOTICE

The maximum tightening torque for the set screws of the proximity switch is 100 Ncm.

Gripper closed:

1. Set the gripper onto "closed" position.
2. Carefully push the closer into the bushing until the proximity switch contacts the control cam.
3. Draw back the proximity switch by appr. 0.5 mm.
4. Fasten the proximity switch with the set-screw (23). In case of PGN 64 fasten the clamping screw at the bracket.
5. Connect the proximity switch.
6. Control the function by opening and closing the gripper.

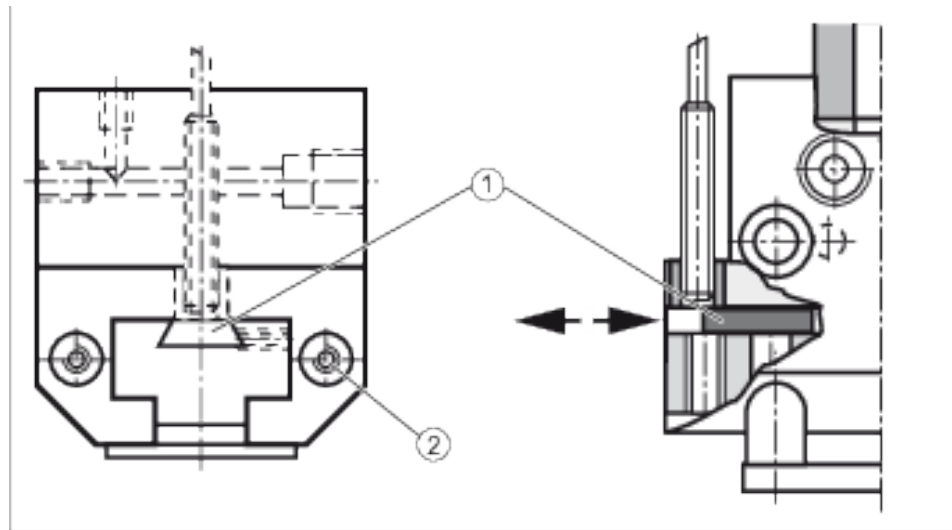
Part gripped:

1. Mount the proximity switch as described before.
2. Set the gripper onto "open" position.
3. Loosen the set-screw (2) which clamps the control cam.
4. Clamp the component to be gripped.
5. Slide the control cam (1) which switches the proximity switch.
6. Carefully set the gripper onto "open" position.
7. Fasten the control cam (1) with the set-screw (2) and check the function.

4.2.6 Operation with a closing and opening proximity switch

In an old standard version of the PGN, the "open" position was monitored with an opener and the "closed" position with a closer.

If a gripper of this version is replaced by a new version, however the existing sensors (1x closer, 1x opener) should still be used, please proceed as follows:

Closed-open monitoring

The position "open" is monitored by an opener, the position "closed" by a closer. The long control cam at the side of the opener has just to be turned by 180°. The nose is no longer turned towards the wedge hook, but is located outside the base jaw (see illustration).

The position of the opening sensor is adjusted now in a way, that it has the largest possible distance to the control cam, is still actuated and therefore doesn't furnish a signal while it traverses area **B** of the control cam.

An output signal is not furnished until the gripper completely opens and edge **K** of the control cam has been passed. Edge **K** therefore determines the switching point of the opening sensor.

Monitoring the status "Gripped" is the same as monitoring "closed" status of a closer.

After the initial adjustment of the control cam, the exact switching points have to be re-adjusted.



- | | |
|---|--|
| 1 | Edge K of the control cam |
| 2 | Even range B of the control cam |
| 3 | Nose |

In case of grippers used for I.D. gripping, the status "gripped" is monitored with the long control cam and the status "closed" with the short one. All the other functions are working in the same way. Depending to the gripper and the monitored position, the long control cam may overhang from the housing and be an interfering contour. In this case the control cam should be shortened.

5 Troubleshooting

5.1 Product does not move?

Possible cause	Corrective action
Base jaws jam in housing, e.g. mounting surface is not sufficiently even.	Check the evenness of the mounting surface. ▶ 4.1.1 [18] Loosen the mounting screws of the product and actuate the product again.
Pressure drops below minimum.	Check air supply. ▶ 4.1.2 [19]
Compressed air lines switched.	Check compressed air lines.
Proximity switch defective or set incorrect.	Readjust or change sensor.
Unused air connections open.	Close unused air connections.
Component part defective.	Replace component or send it to SCHUNK for repair.
Air or control line swapped	Check whether the adapter plate is stepped (only in the case of lateral attachment)

5.2 Product does not travel the entire stroke

Possible cause	Corrective action
Dirt deposits between cover and piston.	Clean and if necessary re-lubricate. ▶ 6 [33]
Pressure drops below minimum.	Check air supply., ▶ 4.1.2 [19]
Mounting surface is not sufficiently flat.	Check the evenness of the mounting surface. ▶ 4.1.1 [18]
Component part defective.	Send product with a SCHUNK repair order or dismantle product.

5.3 Product is opening or closing abruptly

Possible cause	Corrective action
Too little grease in the mechanical guiding areas.	Clean and lubricate product.
Compressed air lines blocked.	Check compressed air lines of damage.
Mounting surface is not sufficiently flat.	Check the evenness of the mounting surface.

5.4 Gripping force is dropping

Possible cause	Corrective action
Compressed air can escape.	Check seals, if necessary, disassemble the product and replace seals.
Too much grease in the mechanical movement space.	Clean and lubricate product.

Possible cause	Corrective action
Pressure drops below minimum.	Check air supply. ▶ 3 [17]
Component part defective.	Replace component or send it to SCHUNK for repair.

5.5 Product does not achieve the opening and closing times

Possible cause	Corrective action
Compressed air lines are not installed optimally.	If present: Open the flow control couplings on the product to the maximum that the movement of the jaws occurs without bouncing and hitting.
	Check compressed air lines.
	Inner diameters of compressed air lines are of sufficient size in relation to compressed air consumption.
	Keep compressed air lines between the product and directional control valve as short as possible.
	Flow rate of valve is sufficiently large relative to the compressed air consumption.
	IMPORTANT! The one-way flow control valve must not be removed even if the opening and closing times are not achieved.
	If, despite optimum air connections, the opening and closing times specified in the catalogue are not achieved, SCHUNK recommends the use of quick-air-vent-valves directly at the product.

6 Maintenance

6.1 Notes



⚠ WARNING

Risk of burns through contact with hot surfaces!

Surfaces of components can heat up severely during operation. Skin contact with hot surfaces causes severe burns to the skin.

- For all work in the vicinity of hot surfaces, wear safety gloves.
- Before carrying out any work, make sure that all surfaces have cooled down to the ambient temperature.

Original spare parts

Use only original spare parts of SCHUNK when replacing spare and wear parts.

Replacement of the housing and base jaws

The base jaws and the guides in the housing are matched to each other. To replace these parts, send the product to SCHUNK with a repair order.

Maintenance of version with gripping force maintenance I.D. gripping and O.D. gripping

The pistons have to be aligned using an assembly device. Therefore we recommend to have the module serviced and the seals replaced by SCHUNK.

6.2 Maintenance interval

NOTICE

Material damage due to hardening lubricants!

Lubricants harden more quickly at temperatures above 60°C, leading to possible product damage.

- Reduce the lubricant intervals accordingly.

Interval [Mio. cycles]	1.5
------------------------	-----

6.3 Lubricants/Lubrication points

SCHUNK recommends the lubricants listed.

Greasing area	Lubricant
Metallic sliding surfaces	Rivolta F.L.G. GT-2
All seals	Rivolta F.L.G. GT-2
Bore hole at the piston	Rivolta F.L.G. GT-2

The product contains food-compliant lubricants as standard. **The requirements of standard EN 1672-2:2020 are not fully met.** During maintenance, treat all greased areas with lubricant. Thinly apply lubricant with a lint-free cloth.

NOTE

- Change contaminated food-compliant lubricant.
 - Observe information in the safety data sheet from the lubricant manufacturer.
-

The guides in the housing can be re-lubricated as needed. Remove the set-screw of the air purge connection and replace it with a lubrication nipple.

6.4 Disassemble the product

6.4.1 Version without gripping force maintenance

Position of the item numbers ▶ 6.6 [41]

1. Remove the compressed air hoses.
2. Remove the cover (5).
3. Mark the installation position of the piston (3/8) and the base jaws (2/7) in the housing (1).
4. Unscrew the screws (11) and remove the cover (4).
5. Unscrew the screws (10) and remove the cylinder piston (6) from the housing (1).
6. Press the piston (3/8) upward out of the housing (1).
7. Pull the base jaws (2/7) out of the housing (1).

6.4.2 Version with gripping force maintenance O.D.

Position of the item numbers ▶ 6.6 [41]

**⚠ WARNING****Risk of injury due to spring forces!**

The cover may be ejected due to the high spring forces.

- Dismantle the product carefully.
-

**⚠ WARNING****Risk of injury due to spring forces!**

The cylinder piston is under spring tension.

- Carefully disassemble the product.
-

1. Remove the compressed air hoses.

2. Remove the cover (5).
3. Mark the installation position of the piston (3/8) and the base jaws (2/7) in the housing (1).
4. **WARNING! Danger of injury due to spring forces! The cylinder piston and the cover plate are under spring tension. Carefully disassemble the module.** Clamp the module between the housing (50) and the cover plate (36) in the bench vice in that way that the four screws (40) can be disassembled.
5. Unscrew the screws (40) .
6. Carefully open the bench vise and remove the cover (36).
7. **WARNING! Risk of injury due to spring forces! The cylinder piston is under spring tension. Carefully disassemble the module.** Clamp the module between the housing (50) and the cylinder piston (37).
8. Unscrew the screws (39).
9. Carefully open the bench vise to remove the surface tension of the pressure spring.
10. Remove the cylinder piston (6) from the housing (1).
11. Press the piston (3/8) upward out of the housing (1).
12. Pull the base jaws (2/7) out of the housing (1).

6.4.3 Version with gripping force maintenance I.D.

Position of the item numbers ► 6.6 [41]



⚠ WARNING

Risk of injury due to spring forces!

The cover may be ejected due to the high spring forces.

- Dismantle the product carefully.

1. Remove the compressed air hoses.
2. Remove the cover (5).
3. Mark the installation position of the piston (3/8) and the base jaws (2/7) in the housing (1).
4. **WARNING! Risk of injury due to spring forces! The cover plate is under spring tension. Carefully disassemble the module.** Clamp the module between the housing (50) and the cover plate (36) in the bench vice in that way that the four screws (40) can be disassembled.
5. Unscrew the screws (40).
6. Carefully open the bench vise to remove the surface tension of the pressure spring.

7. Remove the cover (36) and the pressure spring.
8. Remove the cylinder piston (6) from the housing (50).
9. Press the piston (3/8) upward out of the housing (50).
10. Pull the base jaws (2/7) out of the housing (50).

6.5 Servicing and assembling the module



⚠ WARNING

Risk of injury due to spring forces!

The cover may be ejected due to the high spring forces.

- Dismantle the product carefully.

Maintenance

- Clean all parts thoroughly and check for damage and wear.
- Replace all wear parts / seals.
- The seals are in the enclosed sealing kit. ▶ 1.4.1 [7]
- Treat all greased areas with lubricant. ▶ 6.3 [33]
- Oil or grease bare external steel parts.
- In the case of the version with gripping force maintenance for „O.D. gripping“, the sizes 50, 64, 125 and 160 have to be mounted with the aid of an assembly device for cylinder pistons. For the sizes 80, 100, 200 and 300 , mount the cylinder piston by using two assembly devices. ▶ 6.5.1 [37]

Assembly

Assembly takes place in the opposite order to disassembly. Observe the following:

- Unless otherwise specified, secure all screws and nuts with Loctite no. 243 and tighten with the appropriate tightening torque. ▶ 6.5.2 [40]

6.5.1 Assembly device

Device 1

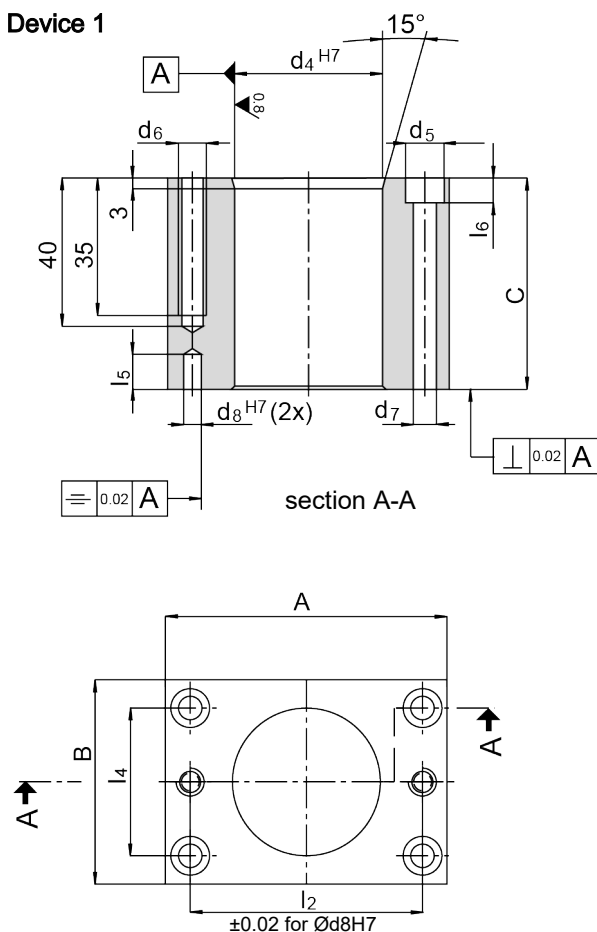

Device 2

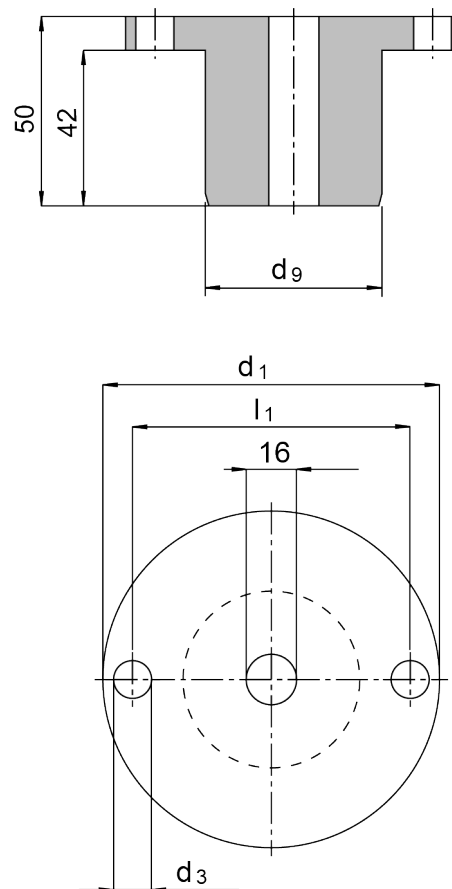

Mounting device cylinder piston

Tab.: Mounting device cylinder piston - dimensions in mm

	PGN							
	50	64	80	100	125	160	200	300
A	45	56	66	80	104	125	150	210
B	32	40	46	53	64	78	100	140
C	27	30	60	60	60	70	70	68
d ₁	-	-	66	80	-	-	150	200
d ₃	-	-	6.6	9	-	-	11	11
d ₄ H7	21	26	34	42	52	64	90	127.5
d ₅	8	10	10	11	15	15	18	26
d ₆	-	-	M6	M8	-	-	M10	M10
d ₇	4.5	5.5	5.5	6.6	9	9	11	17.5
d ₈ H7	3	4	4	5	6	6	8	10
d ₉	-	-	33	41	-	-	89	126
l ₁	-	-	52	66	-	-	130	180

	PGN							
	50	64	80	100	125	160	200	300
l_2	35	42	52	66	82	100	130	180
l_4	22	27	32	38	45	56	70	95
l_5	5	6	8	10	10	12	16	16
l_6	4.5	6	6	7	9	9	11	17.5

Position of the item numbers ▶ 6.6 [41]

Tab.: Screws for assembly device

Item	Designation	PGN							
		50	64	80	100	125	160	200	300
102	Screw (DIN EN ISO 4762)	M4 x 25	M5 x 30	M5 x 60	M6 x 60	M8 x 60	M8 x 70	M10 x 80	M16 x 70
103	Screw (DIN EN ISO 4762)	-	-	M6 x 40	M8 x 40	-	-	M10 x 55	M10 x 40

**Assembly with device
for PGN 50, 64, 125
and 160**

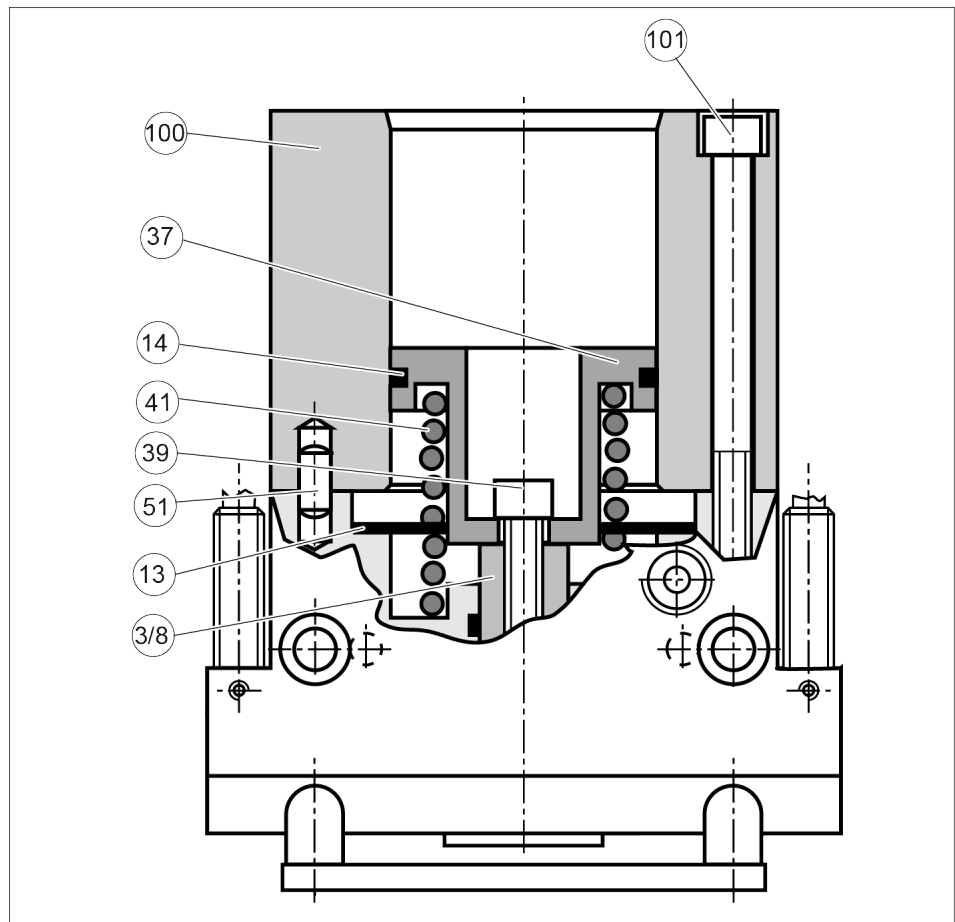

Assembly of the mounting device

1. Assemble the base jaws and piston with sealing in the housing.
2. Insert the pressure spring into the housing (41).

3. Carefully slip device 1 (100) over the cylinder piston and assemble it with screws (101) on the housing.
4. Carefully insert the cylinder piston (37) without seal into the device bore and push it until it contacts the spring (41).
5. Insert the screw (39) and tighten it with the required torque ▶ 6.5.2 [□ 40].
6. Remove assembly device.
7. Carefully place the seal (13) onto the housing.
8. Locate the seal of the cylinder piston (14).
9. Assemble the cover (36).

**Assembly with device
for PGN 80, 100, 200
and 300**

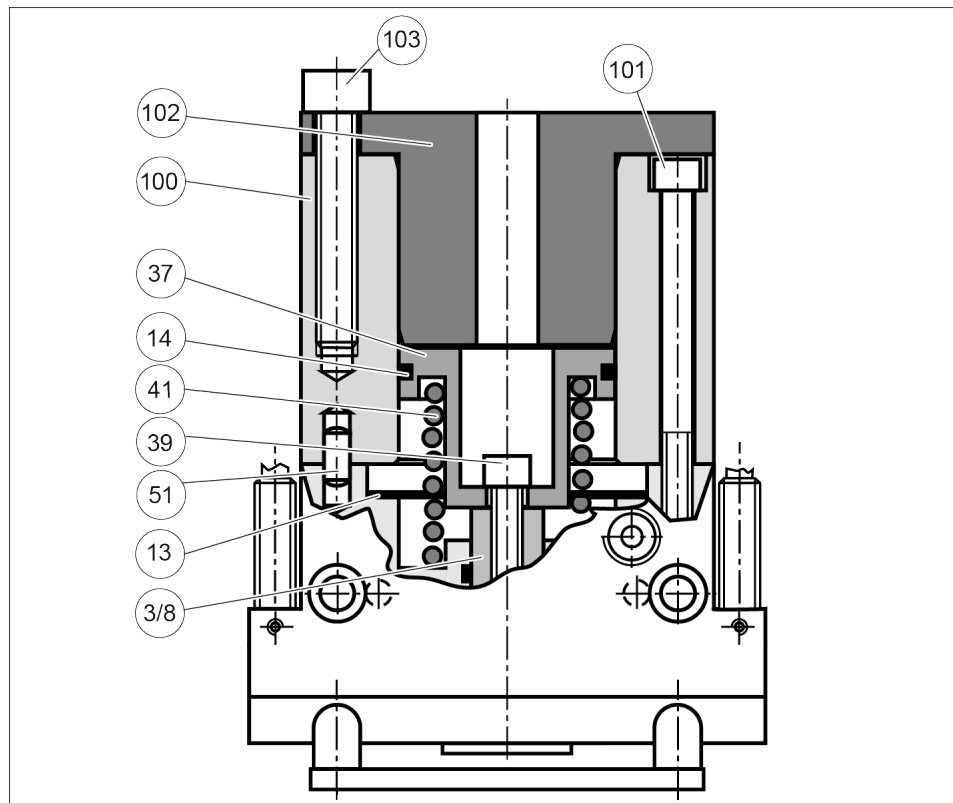

Assembly of the mounting device

1. Assemble the base jaws and piston with sealing in the housing.
2. Insert the pressure spring into the housing (41).
3. Carefully slip device 1 (100) over the cylinder piston and assemble it with screws (101) on the housing.
4. Carefully insert the cylinder piston (37) without seal into the device bore and push it until it contacts the spring (41).
5. Locate device 2 and screw it onto device 1 evenly until the cylinder piston contacts the piston rod.
6. Insert the screw (39) and tighten it with the required torque ▶ 6.5.2 [□ 40].
7. Remove assembly device.

8. Carefully place the seal (13) onto the housing.
9. Locate the seal of the cylinder piston (14).
10. Assemble the cover (36).

6.5.2 Screw tightening torques

Position of the item numbers ► 6.6 [📄 41]

Item	PGN								
	50 [Nm]	64 [Nm]	80 [Nm]	100 [Nm]	125 [Nm]	160 [Nm]	200 [Nm]	300 [Nm]	380 [Nm]
10	0.8	5.8	12	12	20	49	75	75	75
11	1.9	1.9	4.9	4.9	2.9	1.9	4.9	4.9	10
39	2.7	14	24	24	57	67	116	116	200
40	2.2	2.2	4.9	4.9	6.0	4.9	10	10	10

6.6 Assembly drawing

The following figure is an example image.
It serves for illustration and assignment of the spare parts.
Variations are possible depending on size and variant.

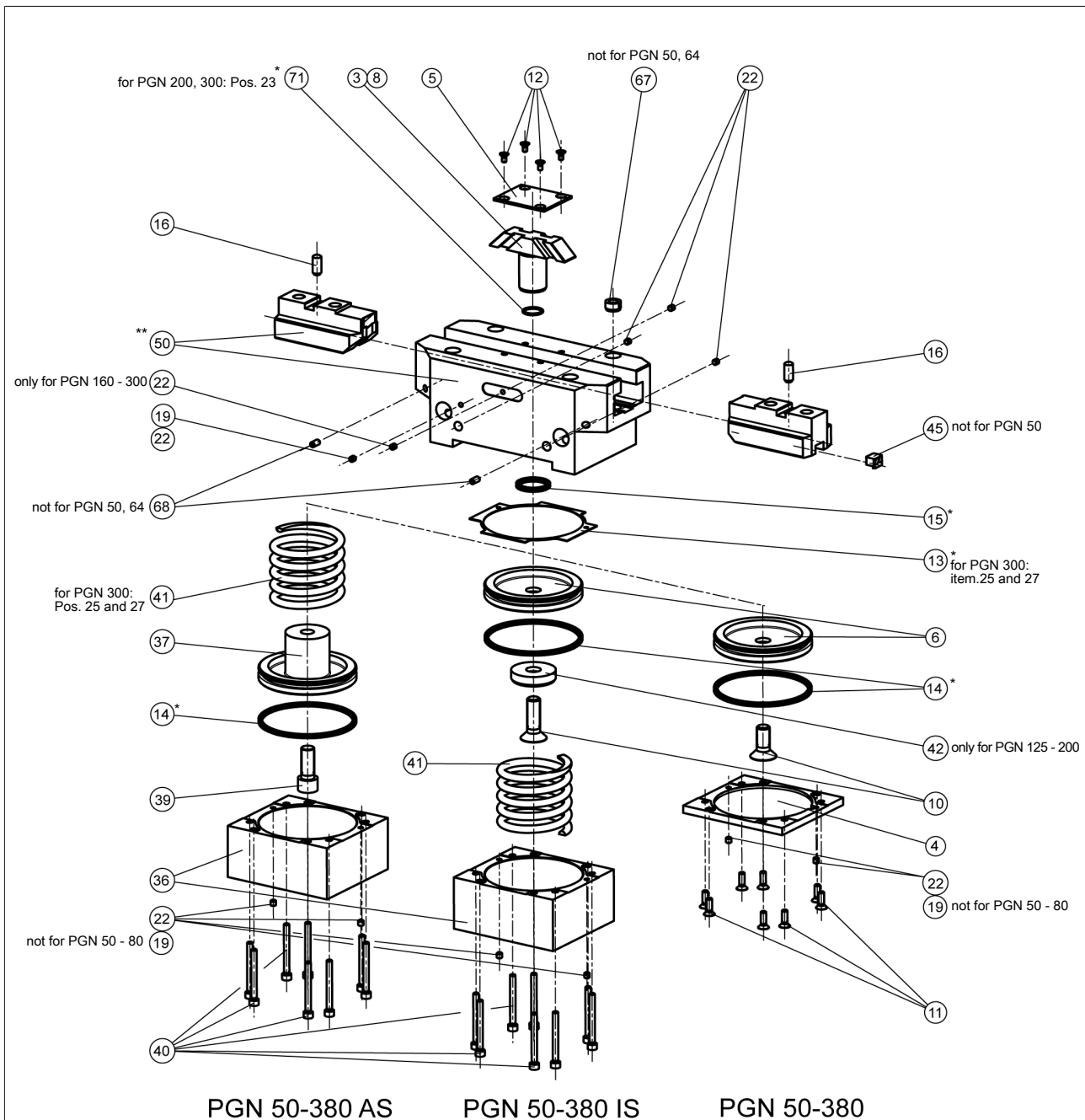

Assembly of the variants "O.D. gripping" (AS) / "I.D. gripping" (IS) / without gripping force maintenance

* Wearing part, replace during maintenance.
Included in the seal kit. Seal kit can only be ordered completely.

** Positions are adapted to each other
and can not be replaced by the customer.

7 Translation of the original declaration of incorporation

in terms of the Directive 2006/42/EG, Annex II, Part 1.B of the European Parliament and of the Council on machinery.

Hersteller/ SCHUNK GmbH & Co. KG Clamping and gripping technology
Inverkehrbringer Bahnhofstr. 106 – 134
D-74348 Lauffen/Neckar

We hereby declare that on the date of the declaration the following partly completed machine complied with all basic safety and health regulations found in the directive 2006/42/EC of the European Parliament and of the Council on machinery. The declaration is rendered invalid if modifications are made to the product.

Product designation: 2-Finger Parallel Gripper / PGN / pneumatic
ID number 0370099 ... 0370447, 39370099 ... 39370107

The partly completed machine may not be put into operation until conformity of the machine into which the partly completed machine is to be installed with the provisions of the Machinery Directive (2006/42/EC) is confirmed.

Applied harmonized standards, especially:

EN ISO 12100:2010 Safety of machinery – General principles for design –
Risk assessment and risk reduction

The manufacturer agrees to forward on demand the relevant technical documentation for the partly completed machinery in electronic form to national authorities.

The relevant technical documentation according to Annex VII, Part B, belonging to the partly completed machinery, has been created.

Person authorized to compile the technical documentation:
Robert Leuthner, Address: see manufacturer's address

Signature: see original declaration

Lauffen/Neckar, February 2023

Dr.-Ing. Manuel Baumeister,
Technology & Innovation

9 Annex to declaration of Incorporation

in accordance with 2006/42/EC, Appendix II, no. 1 B

as well as

in accordance with the Supply of Machinery (Safety) Regulations 2008.

1. Description of the basic safety and health protection requirements, as per 2006/42/EC, Annex I and per the Supply of Machinery (Safety) Regulations 2008, that apply to and are fulfilled for the scope of the incomplete machine:

Product designation	2-Finger Parallel Gripper
Type designation	PGN
ID number	0370099 ... 0370447, 39370099 ... 39370107

Legend:

To be provided by the System Integrator for the overall machine



Fulfilled for the scope of the partly completed machine





























Not relevant





1.1 Essential Requirements		
1.1.1	Definitions	✓
1.1.2	Principles of safety integration	✓
1.1.3	Materials and products	✓
1.1.4	Lighting	✓
1.1.5	Design of machinery to facilitate its handling	✓
1.1.6	Ergonomics	✓
1.1.7	Operating positions	Person icon
1.1.8	Seating	Person icon
1.2 Control Systems		
1.2.1	Safety and reliability of control systems	✓
1.2.2	Control devices	✓
1.2.3	Starting	✓
1.2.4	Stopping	✓
1.2.4.1	Normal stop	✓
1.2.4.2	Operational stop	✓
1.2.4.3	Emergency stop	✓
1.2.4.4	Assembly of machinery	✓
1.2.5	Selection of control or operating modes	✓

1.2	Control Systems	
1.2.6	Failure of the power supply	
1.3	Protection against mechanical hazards	
1.3.1	Risk of loss of stability	
1.3.2	Risk of break-up during operation	
1.3.3	Risks due to falling or ejected objects	
1.3.4	Risks due to surfaces, edges or angles	
1.3.5	Risks related to combined machinery	
1.3.6	Risks related to variations in operating conditions	
1.3.7	Risks related to moving parts	
1.3.8	Choice of protection against risks arising from moving parts	
1.3.8.1	Moving transmission parts	
1.3.8.2	Moving parts involved in the process	
1.3.9	Risks of uncontrolled movements	
1.4	Required characteristics of guards and protective devices	
1.4.1	General requirements	
1.4.2	Special requirements for guards	
1.4.2.1	Fixed guards	
1.4.2.2	Interlocking movable guards	
1.4.2.3	Adjustable guards restricting access	
1.4.3	Special requirements for protective devices	
1.5	Risks due to other hazards	
1.5.1	Electricity supply	
1.5.2	Static electricity	
1.5.3	Energy supply other than electricity	
1.5.4	Errors of fitting	
1.5.5	Extreme temperatures	
1.5.6	Fire	
1.5.7	Explosion	
1.5.8	Noise	
1.5.9	Vibrations	
1.5.10	Radiation	
1.5.11	External radiation	

1.5	Risks due to other hazards	
1.5.12	Laser radiation	
1.5.13	Emissions of hazardous materials and substances	
1.5.14	Risk of being trapped in a machine	
1.5.15	Risk of slipping, tripping or falling	
1.5.16	Lightning	
1.6	Maintenance	
1.6.1	Machinery maintenance	
1.6.2	Access to operating positions and servicing points	
1.6.3	Isolation of energy sources	
1.6.4	Operator intervention	
1.6.5	Cleaning of internal parts	
1.7	Information	
1.7.1	Information and warnings on the machinery	
1.7.1.1	Information and information devices	
1.7.1.2	Warning devices	
1.7.2	Warning of residual risks	
1.7.3	Marking of machinery	
1.7.4	Instructions	
1.7.4.1	General principles for the drafting of instructions	
1.7.4.2	Contents of the instructions	
1.7.4.3	Sales literature	
The classification from Annex 1 is to be supplemented from here forward.		
2	Supplementary essential health and safety requirements for certain categories of machinery	
2.1	Foodstuffs machinery and machinery for cosmetics or pharmaceutical products	
2.2	Portable hand-held and/or guided machinery	
2.2.1	Portable fixing and other impact machinery	
2.3	Machinery for working wood and material with similar physical characteristics	
3	Supplementary essential health and safety requirements to offset hazards due to the mobility of machinery	
4	Supplementary essential health and safety requirements to offset hazards due to lifting operations	

The classification from Annex 1 is to be supplemented from here forward.

5	Supplementary essential health and safety requirements for machinery intended for underground work	
6	Supplementary essential health and safety requirements for machinery presenting particular hazards due to the lifting of persons	



SCHUNK GmbH & Co. KG
Clamping and gripping technology

Bahnhofstr. 106 - 134
D-74348 Lauffen/Neckar
Tel. +49-7133-103-0
Fax +49-7133-103-2399
info@de.schunk.com
schunk.com

Folgen Sie uns | *Follow us*



Wir drucken nachhaltig | *We print sustainable*