

Assembly and operating manual

PSH

2-Finger-Parallel Gripper

Translation of the original manual

Hand in hand for tomorrow

Imprint

Copyright:

This manual is protected by copyright. The author is SCHUNK SE & Co. KG.
All rights reserved.

Technical changes:

We reserve the right to make alterations for the purpose of technical improvement.

Document number: 389331

Version: 19.00 | 11/11/2025 | en

Dear Customer,

Thank you for trusting our products and our family-owned company, the leading technology supplier of robots and production machines.

Our team is always available to answer any questions on this product and other solutions. Ask us questions and challenge us. We will find a solution!

Best regards,

Your SCHUNK team

Customer Management

Tel. +49-7133-103-2503

Fax +49-7133-103-2189

cmg@de.schunk.com



Please read the operating manual in full and keep it close to the product.

Table of Contents

1 General	5
1.1 About this manual	5
1.1.1 Presentation of Warning Labels	5
1.1.2 Applicable documents	6
1.1.3 Sizes	6
1.1.4 Variants	6
1.2 Warranty	6
1.3 Scope of delivery	7
1.4 Accessories	7
2 Notes on particular risks	8
3 Basic safety notes	10
3.1 Intended use	10
3.2 Constructional changes	10
3.3 Spare parts	10
3.4 Gripper fingers	10
3.5 Ambient conditions and operating conditions	11
3.6 Personnel qualification	11
3.7 Personal protective equipment	12
3.8 Notes on safe operation	13
3.9 Transport	13
3.10 Malfunctions	13
3.11 Disposal	14
3.12 Fundamental dangers	14
3.12.1 Protection during handling and assembly	14
3.12.2 Protection during commissioning and operation	15
3.12.3 Protection against dangerous movements	15
3.12.4 Protection against electric shock	15
3.13 Notes on particular risks	16
4 Technical Data	18
4.1 Name plate	18
5 Design and description	19
5.1 Design	19
5.2 Description	19
6 Assembly	20
6.1 Assembly and connection	20
6.2 Connections	22
6.2.1 Mechanical connection	22

6.2.2	Pneumatic connection.....	24
6.3	Mounting the sensor.....	26
6.3.1	Overview of sensors	26
6.3.2	Mounting MMS 30 magnetic switch	27
6.3.3	Mounting inductive proximity switch IN 80.....	28
6.3.4	Mount flexible position sensor FPS	30
7	Troubleshooting.....	31
7.1	Product is not moving	31
7.2	The module does not travel through the entire stroke	31
7.3	Product opens or closes abruptly	31
7.4	Gripping force is dropping.....	32
8	Maintenance	33
8.1	Notes.....	33
8.2	Maintenance intervals.....	33
8.3	Lubricants/Lubrication points.....	34
8.4	Dismantle product.....	35
8.5	Servicing and assembling the product	36
8.6	Screw tightening torques	36
8.7	Assembly drawing	37
9	Translation of the original declaration of incorporation	38
10	UKCA declaration of incorporation	39
11	Information on the RoHS Directive, REACH Regulation and Substances of Very High Concern (SVHC)	40

1 General

1.1 About this manual

This manual contains important information for a safe and appropriate use of the product.

This manual is an integral part of the product and must be kept accessible for the personnel at all times.

Before starting work, the personnel must have read and understood this operating manual. Prerequisite for safe working is the observance of all safety instructions in this manual.

In addition to these instructions, the documents listed under ▶ 1.1.2 [6] are applicable.

NOTE: The illustrations in this manual are intended to provide a basic understanding and may deviate from the actual version.

1.1.1 Presentation of Warning Labels

To make risks clear, the following signal words and symbols are used for safety notes.



⚠ DANGER

Dangers for persons!

Non-observance will inevitably cause irreversible injury or death.



⚠ WARNING

Dangers for persons!

Non-observance can lead to irreversible injury and even death.



⚠ CAUTION

Dangers for persons!

Non-observance can cause minor injuries.

NOTICE

Material damage!

Information about avoiding material damage.

1.1.2 Applicable documents

- General terms of business *
- Catalog data sheet of the purchased product *
- Assembly and operating manuals of the accessories *
- For ATEX versions: Supplementary sheet "Installation and operating instructions - EX" *

The documents labeled with an asterisk (*) can be downloaded from schunk.com/downloads.

1.1.3 Sizes

This operating manual applies to the following sizes:

- PSH 22
- PSH 32
- PSH 42
- PSH 52

1.1.4 Variants

This operating manual applies to the following variations:

- PSH stroke 1
- PSH stroke 2
- PSH high-temperature (V/HT)
- PSH ATEX (EX)

1.2 Warranty

If the product is used as intended, the warranty is valid for 24 months from the ex-works delivery date under the following conditions:

- Observe the specified maintenance and lubrication intervals
- Observe the ambient conditions and operating conditions

Parts touching the workpiece and wear parts are not included in the warranty.

1.3 Scope of delivery

The scope of delivery includes

- 2-Finger-Parallel Gripper PSH in the version ordered
- Accessory pack

Content of the accessory pack:

- 6 x centering sleeves for mounting
- 2 x O-rings for hose-free direct connection

Size	ID number
22	5510897
22 V/HT	395510897
32	5510898
32 V/HT	395510898
42	5510899
42 V/HT	395510899
52	5510900
52 V/HT	395510900

Tab.: ID.-No. of the accessory pack

1.4 Accessories

A wide range of accessories are available for this product

For information regarding which accessory articles can be used with the corresponding product variants, see catalog data sheet.

contents of the sealing kit, ► 8.7 [37].

Seal kit

Size	ID number
22	0370828
22 V/HT	0370919
32	0370829
32 V/HT	0370918
42	0370830
42 V/HT	0370910
52	0370831
52 V/HT	0370911

Tab.: ID. No. spare part kit "Seal kit"

2 Notes on particular risks



⚠ DANGER

Risk of fatal injury from suspended loads!

Falling loads can cause serious injuries and even death.

- Stand clear of suspended loads and do not step within their swiveling range.
- Never move loads without supervision.
- Do not leave suspended loads unattended.
- Wear suitable protective equipment.



⚠ WARNING

Risk of injury from objects falling and being ejected!

Falling and ejected objects during operation can lead to serious injury or death.

- Take appropriate protective measures to secure the danger zone.



⚠ WARNING

Risk of injury due to unexpected movements!

If the power supply is switched on or residual energy remains in the system, components can move unexpectedly and cause serious injuries.

- Before starting any work on the product: Switch off the power supply and secure against restarting.
- Make sure, that no residual energy remains in the system.



⚠ WARNING

Risk of injury from crushing and impacts!

Serious injury could occur during movement of the base jaw, due to breakage or loosening of the gripper fingers or if the workpiece is lost.

- Wear suitable protective equipment.
- Do not reach into the open mechanism or the movement area of the product.



⚠ WARNING

Risk of injury from sharp edges and corners!

Sharp edges and corners can cause cuts.

- Use suitable protective equipment.
-

3 Basic safety notes

3.1 Intended use

The product is designed exclusively for gripping and temporarily holding workpieces or objects.

- The product may only be used within the scope of its technical data, ▶ 4 [18].
- The product is intended for installation in a machine/ automated system. The applicable guidelines for the machine/ automated system must be observed and complied with.
- The product is intended for industrial and industry-oriented use. Its use outside enclosed spaces is only permitted if suitable protective measures are taken against outdoor exposure. The product is not suitable for use in salty air.
- The product can be used within the permissible load limits and technical data for holding workpieces during simple machining operations, but is not a clamping device according to EN 1550:1997+A1:2008.
- Appropriate use of the product includes compliance with all instructions in this manual.
- Any utilization that exceeds or differs from the appropriate use is regarded as misuse.

3.2 Constructional changes

Implementation of structural changes

Modifications, changes or reworking, e.g. additional threads, holes, or safety devices, can damage the product or impair its functionality or safety.

- Structural changes should only be made with the written approval of SCHUNK.

3.3 Spare parts

Use of unauthorized spare parts

Using unauthorized spare parts can endanger personnel and damage the product or cause it to malfunction.

- Use only original spare parts or spares authorized by SCHUNK.

3.4 Gripper fingers

Requirements for the gripper fingers

Accumulated energy can make the product unsafe and risk the danger of serious injuries and considerable material damage.

- Only change gripper fingers if no residual energy can be released.
- Make sure that the product and the top jaws are a sufficient size for the application.

3.5 Ambient conditions and operating conditions

Required ambient conditions and operating conditions

Incorrect ambient and operating conditions can make the product unsafe, leading to the risk of serious injuries, considerable material damage and/or a significant reduction to the product's life span.

- Make sure that the product is used only in the context of its defined application parameters, ▶ 4 [18].
- Make sure that the product is a sufficient size for the application.
- Make sure that the environment is free from splash water and vapors as well as from abrasion or processing dust. Exceptions are products that are designed especially for contaminated environments.

3.6 Personnel qualification

Inadequate qualifications of the personnel

If the personnel working with the product is not sufficiently qualified, the result may be serious injuries and significant property damage.

- All work may only be performed by qualified personnel.
- Before working with the product, the personnel must have read and understood the complete assembly and operating manual.
- Observe the national safety regulations and rules and general safety instructions.

The following personal qualifications are necessary for the various activities related to the product:

Trained electrician

Due to their technical training, knowledge and experience, trained electricians are able to work on electrical systems, recognize and avoid possible dangers and know the relevant standards and regulations.

Qualified personnel

Due to its technical training, knowledge and experience, qualified personnel is able to perform the delegated tasks, recognize and avoid possible dangers and knows the relevant standards and regulations.

Instructed person	Instructed persons were instructed by the operator about the delegated tasks and possible dangers due to improper behaviour.
Service personnel of the manufacturer	Due to its technical training, knowledge and experience, service personnel of the manufacturer is able to perform the delegated tasks and to recognize and avoid possible dangers.

3.7 Personal protective equipment

Use of personal protective equipment

Personal protective equipment serves to protect staff against danger which may interfere with their health or safety at work.

- When working on and with the product, observe the occupational health and safety regulations and wear the required personal protective equipment.
- Observe the valid safety and accident prevention regulations.
- Wear protective gloves to guard against sharp edges and corners or rough surfaces.
- Wear heat-resistant protective gloves when handling hot surfaces.
- Wear protective gloves and safety goggles when handling hazardous substances.
- Wear close-fitting protective clothing and also wear long hair in a hairnet when dealing with moving components.

3.8 Notes on safe operation

Incorrect handling of the personnel

Incorrect handling and assembly may impair the product's safety and cause serious injuries and considerable material damage.

- Avoid any manner of working that may interfere with the function and operational safety of the product.
- Use the product as intended.
- Observe the safety notes and assembly instructions.
- Do not expose the product to any corrosive media. This does not apply to products that are designed for special environments.
- Eliminate any malfunction immediately.
- Observe the care and maintenance instructions.
- Observe the current safety, accident prevention and environmental protection regulations regarding the product's application field.

3.9 Transport

Handling during transport

Incorrect handling during transport may impair the product's safety and cause serious injuries and considerable material damage.

- When handling heavy weights, use lifting equipment to lift the product and transport it by appropriate means.
- Secure the product against falling during transportation and handling.
- Stand clear of suspended loads.

3.10 Malfunctions

Behavior in case of malfunctions

- Immediately remove the product from operation and report the malfunction to the responsible departments/persons.
- Order appropriately trained personnel to rectify the malfunction.
- Do not recommission the product until the malfunction has been rectified.
- Test the product after a malfunction to establish whether it still functions properly and no increased risks have arisen.

3.11 Disposal

Handling of disposal

The incorrect handling of disposal may impair the product's safety and cause serious injuries as well as considerable material and environmental harm.

- Follow local regulations on dispatching product components for recycling or proper disposal.

3.12 Fundamental dangers

General

- Observe safety distances.
- Never deactivate safety devices.
- Before commissioning the product, take appropriate protective measures to secure the danger zone.
- Disconnect power sources before installation, modification, maintenance, or calibration. Ensure that no residual energy remains in the system.
- If the energy supply is connected, do not move any parts by hand.
- Do not reach into the open mechanism or movement area of the product during operation.

3.12.1 Protection during handling and assembly

Incorrect handling and assembly

Incorrect handling and assembly may impair the product's safety and cause serious injuries and considerable material damage.

- Have all work carried out by appropriately qualified personnel.
- For all work, secure the product against accidental operation.
- Observe the relevant accident prevention rules.
- Use suitable assembly and transport equipment and take precautions to prevent jamming and crushing.

Incorrect lifting of loads

Falling loads may cause serious injuries and even death.

- Stand clear of suspended loads and do not step into their swiveling range.
- Never move loads without supervision.
- Do not leave suspended loads unattended.

3.12.2 Protection during commissioning and operation

Falling or violently ejected components

Falling and violently ejected components can cause serious injuries and even death.

- Take appropriate protective measures to secure the danger zone.
- Never step into the danger zone during operation.

3.12.3 Protection against dangerous movements

Unexpected movements

Residual energy in the system may cause serious injuries while working with the product.

- Switch off the energy supply, ensure that no residual energy remains and secure against inadvertent reactivation.
- Never rely solely on the response of the monitoring function to avert danger. Until the installed monitors become effective, it must be assumed that the drive movement is faulty, with its action being dependent on the control unit and the current operating condition of the drive. Perform maintenance work, modifications, and attachments outside the danger zone defined by the movement range.
- To avoid accidents and/or material damage, human access to the movement range of the machine must be restricted. Limit/prevent accidental access for people in this area due through technical safety measures. The protective cover and protective fence must be rigid enough to withstand the maximum possible movement energy. EMERGENCY STOP switches must be easily and quickly accessible. Before starting up the machine or automated system, check that the EMERGENCY STOP system is working. Prevent operation of the machine if this protective equipment does not function correctly.

3.12.4 Protection against electric shock

Possible electrostatic energy

Components or assembly groups may become electrostatically charged. When the electrostatic charge is touched, the discharge may trigger a shock reaction leading to injuries.

- The operator must ensure that all components and assembly groups are included in the local potential equalisation in accordance with the applicable regulations.

- While paying attention to the actual conditions of the working environment, the potential equalisation must be implemented by a specialist electrician according to the applicable regulations.
- The effectiveness of the potential equalisation must be verified by executing regular safety measurements.

3.13 Notes on particular risks



⚠ DANGER

Risk of fatal injury from suspended loads!

Falling loads can cause serious injuries and even death.

- Stand clear of suspended loads and do not step within their swiveling range.
- Never move loads without supervision.
- Do not leave suspended loads unattended.
- Wear suitable protective equipment.



⚠ WARNING

Risk of injury from objects falling and being ejected!

Falling and ejected objects during operation can lead to serious injury or death.

- Take appropriate protective measures to secure the danger zone.



⚠ WARNING

Risk of injury due to unexpected movements!

If the power supply is switched on or residual energy remains in the system, components can move unexpectedly and cause serious injuries.

- Before starting any work on the product: Switch off the power supply and secure against restarting.
- Make sure, that no residual energy remains in the system.



⚠ WARNING

Risk of injury from crushing and impacts!

Serious injury could occur during movement of the base jaw, due to breakage or loosening of the gripper fingers or if the workpiece is lost.

- Wear suitable protective equipment.
- Do not reach into the open mechanism or the movement area of the product.



⚠ WARNING

Risk of injury from sharp edges and corners!

Sharp edges and corners can cause cuts.

- Use suitable protective equipment.

4 Technical Data

Designation	Value
Pressure medium	Compressed air, compressed air quality according to ISO 8573-1:2010 [7:4:4]
Nominal operating pressure [bar]	6
Minimum pressure [bar]	3
Maximum pressure [bar]	8

Ambient conditions and operating conditions

Designation	Value
Ambient temperature [°C] min.	+5
Ambient temperature [°C] max.	90
Ambient temperature [°C] max. (variant V/HT)	130
Noise emission [dB(A)]	≤70

More technical data is included in the catalog data sheet. Whichever is the latest version.

4.1 Name plate



1	Product designation
2	ID
3	Serial number
4	Data matrix code

Scan code or enter serial number on the web and get all the product information: operating manuals, spare parts packages, software updates and much more.

For further information, visit [schunk.com/serialisierung](https://www.schunk.com/serialisierung)

A separate app may be required for scanning with a mobile phone.

5 Design and description

5.1 Design

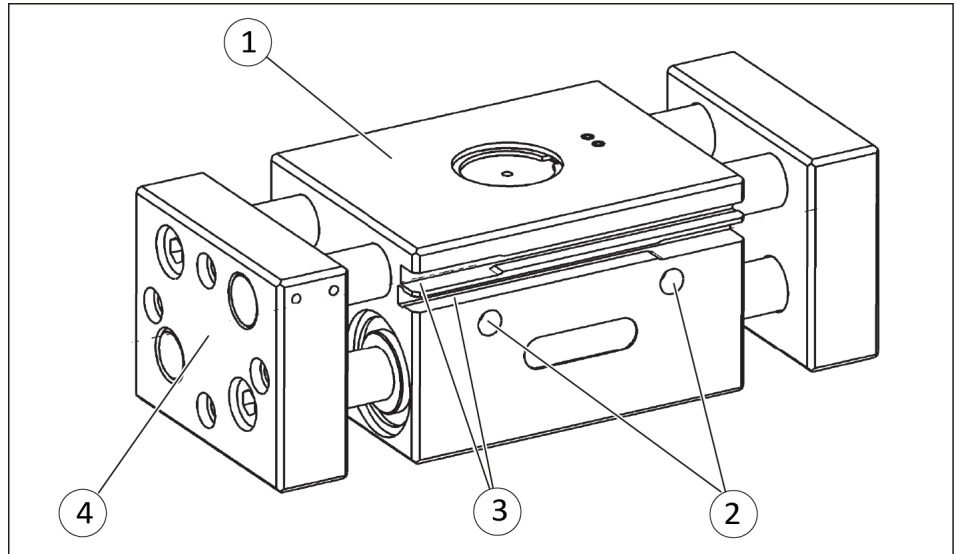

2-Finger-Parallel Gripper

- | | |
|---|--------------------------------|
| 1 | Housing |
| 2 | Compressed air main connection |
| 3 | Groove for sensors |
| 4 | Base jaw |

5.2 Description

2-finger parallel gripper with long jaw stroke and dirt-resistant round guidance

6 Assembly

6.1 Assembly and connection



⚠ WARNING

Risk of injury due to unexpected movements!

If the power supply is switched on or residual energy remains in the system, components can move unexpectedly and cause serious injuries.

- Before starting any work on the product: Switch off the power supply and secure against restarting.
- Make sure, that no residual energy remains in the system.

NOTICE

Risk of damage to the gripper!

If the maximum permissible finger weight or the permissible mass moment of inertia of the fingers is exceeded, the gripper can be damaged.

- As a rule, a jaw movement must take place without impact and bouncing.
- To do this, carry out sufficient throttling and/or damping if necessary.
- Observe specifications in the catalog data sheet.

NOTE

- Observe the requirements for the compressed air supply, ▶ 4 [18].
- In case of compressed air loss (cutting off the energy line), the components lose their dynamic effects and do not remain in a secure position. However, the use of a SDV-P pressure maintenance valve is recommended in this case in order to maintain the dynamic effect for some time. Product variants are also offered with mechanical gripping force via springs, which also ensure a minimum clamping force in the event of a pressure drop.

1. Check the evenness of the mounting surface, ▶ 6.2.1 [22].
2. Only open the required air connections (main connection or direct connection), ▶ 6.2.2 [24].
3. Connect the product via the hose-free direct connection.
 - ⇒ Use O-rings from the accessory pack.
 - ⇒ Seal main air connections which are not required with locking screws.
4. OR: Connect compressed air lines to the main air connections "A" and "B".
 - ⇒ Remove the locking screws.
 - ⇒ Screw in air connections (plug connections).
OR: Screw on throttle valve in order to be able to perform sufficient throttling and/or damping.
5. Screw the product to the machine/system, ▶ 6.2.1 [22].
 - ⇒ If necessary, use appropriate connection elements (adapter plates).
 - ⇒ Observe the maximal tightening torque, admissible screw-in depth and, if necessary, strength class.
6. Secure the gripper fingers to the base jaws, ▶ 6.2.1 [22].
 - ⇒ Observe the maximal tightening torque, admissible screw-in depth and, if necessary, strength class.
7. Connect the sensor, see assembly and operating manual of the sensor.
8. Mount the sensor, ▶ 6.3 [26].

6.2 Connections

6.2.1 Mechanical connection



Evenness of the mounting surface

Metric version

⚠ DANGER

Danger of explosion in potentially explosive areas!

- Observe supplementary sheet for products with explosion-resistant versions "PSH -...-EX".

The values apply to the whole mounting surface to which the product is mounted.

Edge length	Permissible unevenness
< 100	< 0.02
> 100	< 0.05

Tab.: Requirements for evenness of the mounting surface (Dimensions in mm)

NOTE

When selecting the fastening screws, observe the values prescribed by SCHUNK, see following table.

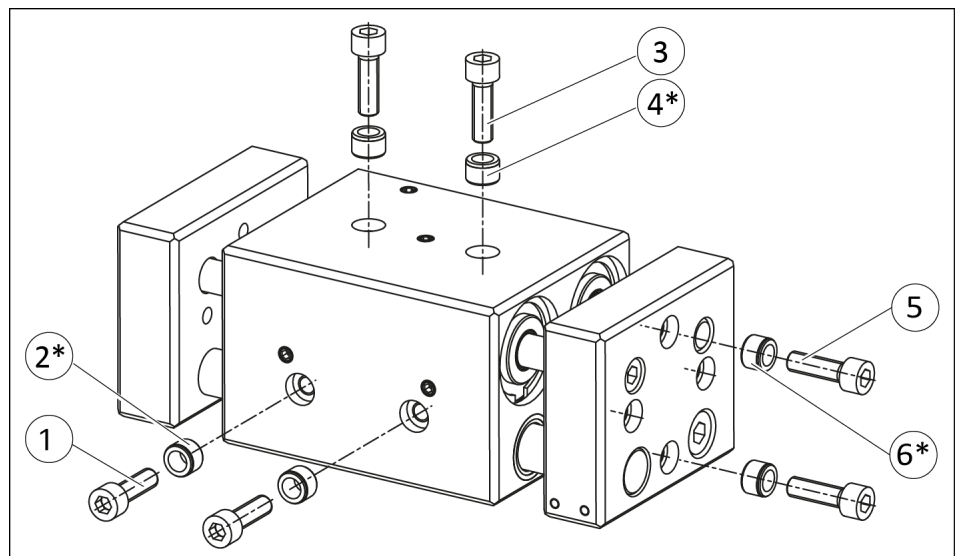

Possible assemblies, metric version

	Connections on side of housing	Connections on top of housing	Connections to the base jaws
Size	① Screws**	③ Screws**	⑤ Screws**
22	M5/10	M5/10	M5/13
32	M6/13	M6/13	M6/16
42	M8/15	M8/15	M8/17
52	M10/20	M10/15	M10/21

Tab.: Connections on the housing

* Contained in accessory pack.

** Thread/Max. depth of engagement from locating surface [mm]

Inch version

NOTE

When selecting the fastening screws, observe the values prescribed by SCHUNK, see following table.

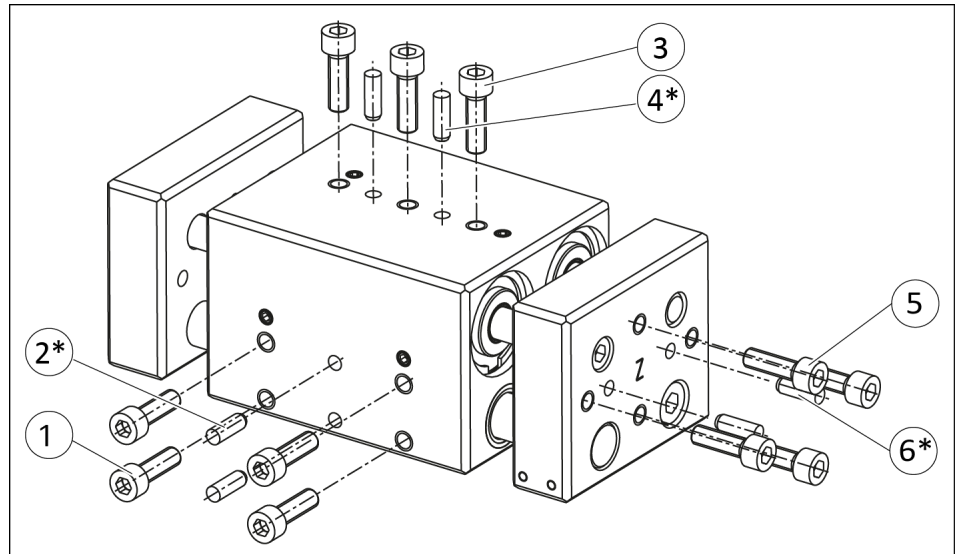

Possible assemblies, inch version

	Connections on side of housing	Connections on top of housing	Connections to the base jaws
Size	① Screws**	③ Screws**	⑤ Screws**
22	#10-32/10	#10-32/10	#10-32/13
32	1/4"-20/9	1/4"-20/9.5	1/4"-20/16
42	1/4"-20/12.5	5/16"-18/12	5/16"-18/26
52	5/16"-18/19	3/8"-16/16	5/16"-18/26

Tab.: Connections on the housing

* Contained in accessory pack.

** Thread/Max. depth of engagement from locating surface [mm]

6.2.2 Pneumatic connection

NOTE

- Observe the requirements for the compressed air supply, ▶ 4 [18].
- In case of compressed air loss (cutting off the energy line), the components lose their dynamic effects and do not remain in a secure position. However, the use of a SDV-P pressure maintenance valve is recommended in this case in order to maintain the dynamic effect for some time. Product variants are also offered with mechanical gripping force via springs, which also ensure a minimum clamping force in the event of a pressure drop.

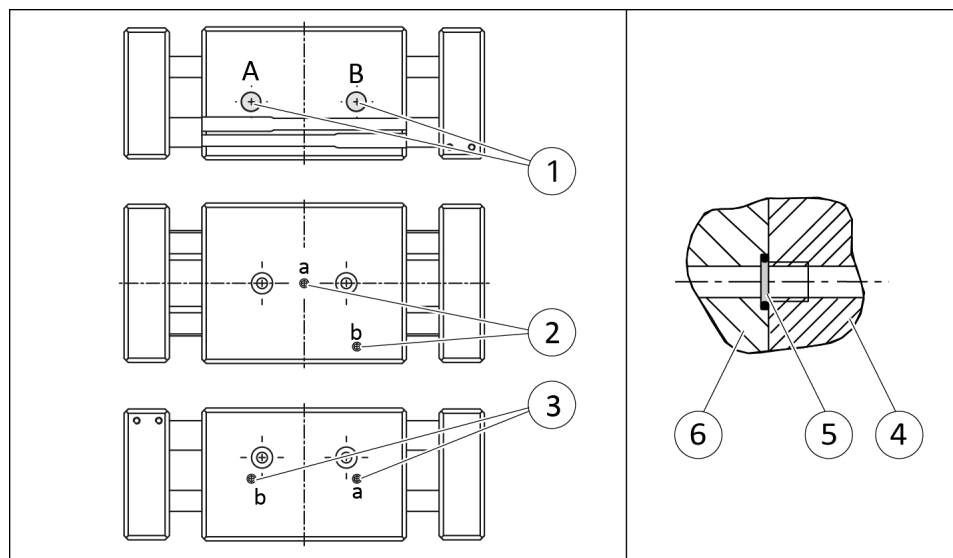

Compressed air connections

1 Main connections (Hose connection)
(A = open, B = close)

2 Hose-free direct connection at the base
(a = open, b = close)

3 Hose-free direct connection

Hose-free direct connection

4 Product

5 O-ring

6 Attachment

Size	Hose connection *	Hose-free direct connection
22 (metric version)	M5/6	M4
22 (inch version)	#10-32/6	M4
32	G 1/8"/6	M5
42	G 1/8"/8	M5
52	G 1/8"/8	M5

Tab.: Thread diameter of the air connections

* Thread / max. depth of engagement from locating surface [mm]

NOTICE

It is imperative that the gripper is throttled when using the side and bottom-sided connections.

The following possibilities are available for throttling the gripper:

- Use of one-way flow control valves
- Minimize the diameter of the air supply holes in the adapter plate
 - Ø1.3 for size 22-1
 - Ø1.0 for size 22-2
 - Ø1.7 for size 32-1
 - Ø1.9 for size 32-2
- Screwing the throttles (22/32) into the threads used for the hose-free direction connection, for item numbers see ► 8.7 [37]

6.3 Mounting the sensor

NOTE

Observe the assembly and operating manual of the sensor for mounting and connecting.

The product is prepared for the use of sensors.

- For the exact type designations of suitable sensors, please see catalog datasheet and ▶ 6.3.1 [📄 26].
- For technical data for the suitable sensors, see assembly and operating manual and catalog datasheet.
 - The assembly and operating manual and catalog datasheet are included in the scope of delivery for the sensors and are available at schunk.com.
- Information on handling sensors is available at schunk.com or from SCHUNK contact persons.

6.3.1 Overview of sensors

Size	MMS 30	IN 80	FPS-S 13
22	✓	✓	✓
32/1	✓	✓	⊘
32/2	✓	✓	✓
42/1	✓	✓	⊘
42/2	✓	✓	✓
52	✓	✓	⊘

6.3.2 Mounting MMS 30 magnetic switch

NOTICE

Risk of damage to the sensor during assembly!

- Observe the maximal tightening torque.

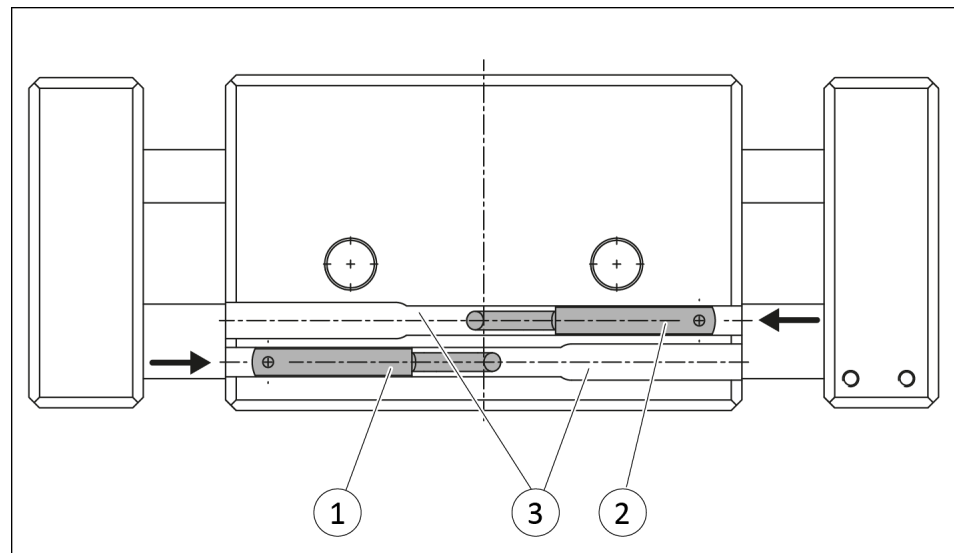

- | | |
|---|---|
| 1 | Magnetic switch 1 |
| 2 | Magnetic switch 2 |
| 3 | Grooves for inserting the magnetic switch |

The sensors can be set to the following switching positions:

Position "Gripper open" or "Part gripped (I.D. gripping)"

1. Bring product in the position in which it is to be set.
2. Push sensor 1 (1) backwards (arrow) into the groove (3) towards the middle of the gripper unit until it switches.
3. Secure the sensor 1 (1) using the set-screw.
Tightening torque: 30 Ncm
4. Bring product into the "Gripper open" or "Part gripped" position and test the function.

Position "Gripper closed" or "Part gripped (O.D. gripping)"

1. Bring product in the position in which it is to be set.
2. Push sensor 2 (2) backwards (arrow) into the groove (3) towards the middle of the gripper unit until it switches.
3. Secure the sensor 2 (2) using the set-screw.
Tightening torque: 30 Ncm
4. Bring product into the "Gripper closed" or "Part gripped" position and test the function.

6.3.3 Mounting inductive proximity switch IN 80

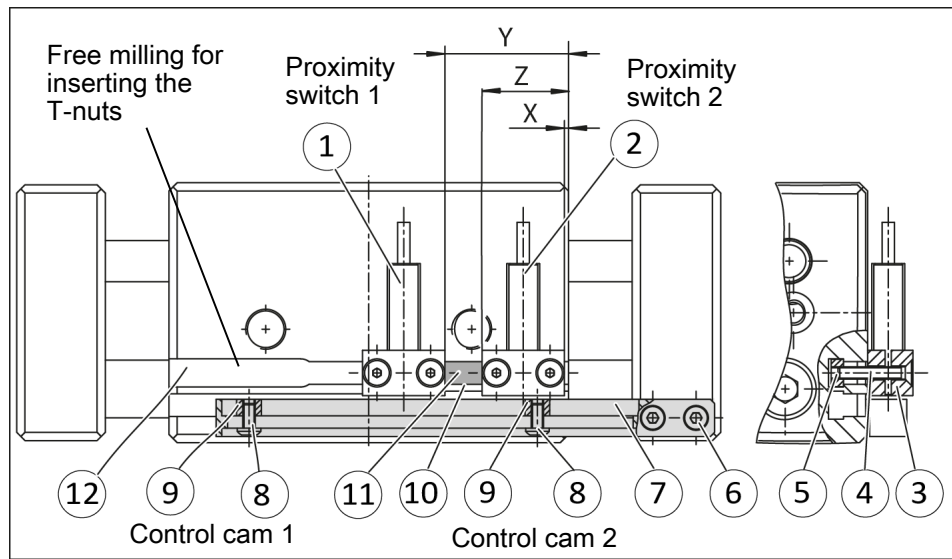

Size	Distance X [mm]	Distance Y [mm]	Distance Z [mm]
22/1	22.5	-	8.0
22/2	15.5	-	1.0
32	-2.0	30.0	18.0
42	3.0	36.0	23.5
52	12.0	40.0	0.0

To be able to mount the sensor, the gripper has to be retrofitted with a special mounting kit.

1. Mount the bracket (7) with screws (6) on the base jaw so that the bracket (7) is above the groove (12) in the housing. Only screw in screws (6) until the bracket (7) can still be turned without play.
2. Secure the screws (6) with Locite No. 243.
3. Place control cams (9) into the oblong hole in the bracket (7) and secure to the bracket using screws (8).
4. Push T-nuts (5) into the groove (12) (for PSH 22 only one T-nut (5)).
5. Secure guide piece (10) with screw (11) to T-nut (5), so that the guide piece (10) can still be pushed further into the groove (12).
6. Fasten the bracket (3) with screws (4) to the T-nuts (5). Only screw in screws (4) until the brackets (3) can be pushed further into the groove (12) (for PSH 22 only one bracket (3)).
7. Screw sensors (1, 2) into the brackets (3) only until they are flush against the brackets.

8. Push brackets (3) and guide piece (10) to the positions "X", "Y" and "Z", for clearance measurements see previous table.
9. Tighten the screws (4).

The sensors can be set to the following switching positions:

Position "Gripper open" or "Part gripped (I.D. gripping)":

1. Bring product in the position in which it is to be set.
2. Loosen screw (8), so that the control cam 1 (9) can be moved in the bracket (7).
3. Slide the control cam 1 (9) to the free end of the bracket.
4. Push control cam 1 (9) back until the sensor 1 (1) switches.
5. Tighten screw (8), in order to fix the control cam in this position.
6. Bring product into the "Gripper open" or "Part gripped" position and test the function.

Position "Gripper closed" or "Part gripped (O.D. gripping)":

1. Bring product in the position in which it is to be set.
2. Loosen screw (8), so that the control cam 2 (9) can be moved in the bracket (7).
3. Slide the control cam 2 (9) to the free end of the bracket.
4. Push control cam 2 (9) back until the sensor 2 (2) switches.
5. Tighten screw (8), in order to fix the control cam in this position.
6. Bring product into the "Gripper closed" or "Part gripped" position and test the function.

6.3.4 Mount flexible position sensor FPS

NOTICE

Risk of damage to the sensor during assembly!

- Observe the maximal tightening torque.

To use the flexible position sensor FPS-M8, the grippers have to be retrofitted with a special mounting kit. This mounting kit is available from SCHUNK for the models below:

- Size 22/1
- Size 22/2
- Size 32/2
- Size 42/2

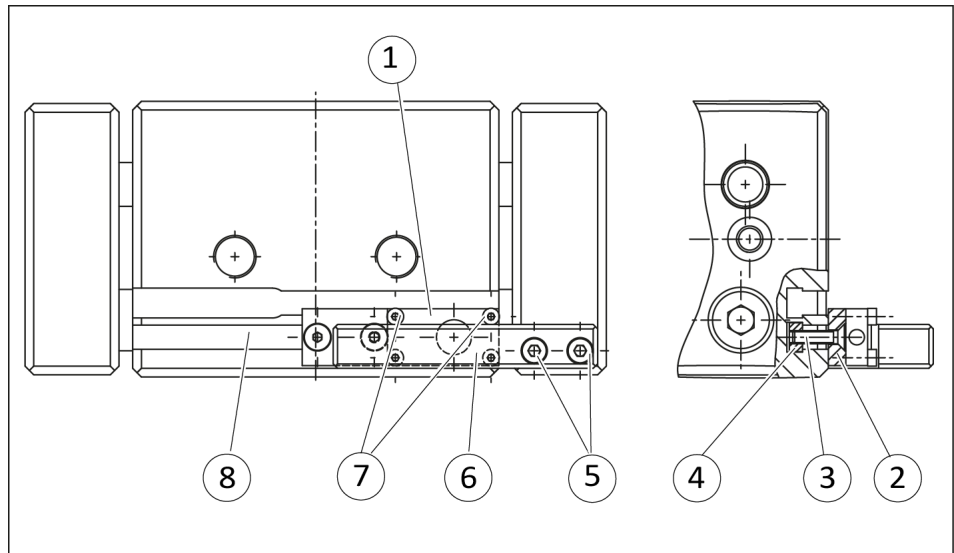

1. Push the T-nut (4) into the groove (8).
2. Secure bracket (2) with two screws (3) to the T-nut (4), so that the bracket (2) is flush with the housing outer edge.
3. Secure sensor (1) with four screws (7) to the bracket (2).
Tightening torque: 1 Nm
4. Excavate sensor cable to the center of the gripper.
5. Secure control cam (6) with screws (5) to the base jaw, so that the control cam (6) is above the sensor (1).

7 Troubleshooting

7.1 Product is not moving

Possible cause	Corrective action
Base jaws jam in housing, e.g. mounting surface is not sufficiently even.	Check the evenness of the mounting surface. ▶ 6.2.1 [22]
	Loosen the mounting screws of the product and actuate the product again.
Pressure drops below minimum.	Check air supply. ▶ 6.2.2 [26]
Compressed air lines switched.	Check compressed air lines. ▶ 6.2.2 [26]
Proximity switch defective or set incorrect.	Readjust or change sensor.
Unused air connections open.	Close unused air connections.
Flow control valve closed.	Open the flow control valve.
Component part defective.	Replace component or send it to SCHUNK for repair.

7.2 The module does not travel through the entire stroke

Possible cause	Corrective action
Dirt between the housing, base jaws, guidance- and piston bar.	Clean and lubricate product. ▶ 8 [33]
Pressure drops below minimum.	Check air supply. ▶ Luftanschlüsse [24]
Mounting surface is not sufficiently flat.	Check the evenness of the mounting surface. ▶ 6.2.1 [22]
Components have come loose e.g. due to overloading.	Send product with a SCHUNK repair order or dismantle product.

7.3 Product opens or closes abruptly

Possible cause	Corrective action
Too little grease in the mechanical guiding areas.	Clean and lubricate product. ▶ 8 [33]
Compressed air lines blocked.	Check compressed air lines of damage.
Mounting surface is not sufficiently flat.	Check the evenness of the mounting surface.
One-way flow control valve is missing or adjustet incorrectly.	Install and adjust one-way flow control valve.
Loading too large.	Check permissible weight and length of the gripper fingers.

7.4 Gripping force is dropping

Possible cause	Corrective action
Compressed air can escape.	Check seals, if necessary, disassemble the product and replace seals.
Too much grease in the mechanical movement space.	Clean and lubricate product.
Pressure drops below minimum.	Check air supply. ▶ 4 [📄 18]
Component part defective.	Replace component or send it to SCHUNK for repair.

8 Maintenance

8.1 Notes



⚠ DANGER

Danger of explosion in potentially explosive areas!

- Observe supplementary sheet for products with explosion-resistant versions "PSH -...-EX".



⚠ WARNING

Risk of burns through contact with hot surfaces!

Surfaces of components can heat up severely during operation. Skin contact with hot surfaces causes severe burns to the skin.

- For all work in the vicinity of hot surfaces, wear safety gloves.
- Before carrying out any work, make sure that all surfaces have cooled down to the ambient temperature.

Original spare parts

Use only original spare parts of SCHUNK when replacing spare and wear parts.

8.2 Maintenance intervals

NOTICE

Material damage due to hardening lubricants!

Lubricants harden more quickly at temperatures above 60°C, leading to possible product damage.

- Reduce the lubricant intervals accordingly.

Interval (million cycles)	Maintenance work
2	Treat all grease areas with lubricant, ▶ 8.3 [34] Oil or grease external steel parts, ▶ 8.3 [34]
2	Clean all parts thoroughly, check for damage and wear, if necessary replace seals and wearing parts, ▶ 8.7 [37]

8.3 Lubricants/Lubrication points

During maintenance, treat all greased areas with lubricant. Thinly apply lubricant with a lint-free cloth.

SCHUNK recommends the lubricants listed.

Greasing area	Lubricant
Metallic sliding surfaces	SCHUNK grease 3
Seals and sealing surfaces	SCHUNK grease 1
Bore hole at the piston	SCHUNK grease 1

Details regarding SCHUNK lubricant designations are available at [schunk.com/lubricants](https://www.schunk.com/lubricants).

The product contains food-compliant lubricants as standard.

The requirements of standard EN 1672-2:2020 are not fully met.

NOTE

- Change contaminated food-compliant lubricant.
 - Observe information in the safety data sheet from the lubricant manufacturer.
-

8.4 Dismantle product



⚠ WARNING

Risk of injury due to unexpected movements!

If the power supply is switched on or residual energy remains in the system, components can move unexpectedly and cause serious injuries.

- Before starting any work on the product: Switch off the power supply and secure against restarting.
- Make sure, that no residual energy remains in the system.

Position of the item numbers ▶ 8.7 [📄 37]

1. Remove the compressed air lines.
2. Disassemble product from the machine/system.
3. Unscrew screws (40 and 41) and lift off base jaws (5 or 6).
4. Remove the safety ring (52).
5. Pull the pinion bearing (15) out of the housing using a screw or a puller.
6. Remove pinion (25) from the housing.
7. **Only size 22:** Pull gear rack with magnet (65) out of the housing.
Size 32, 42, 52: Pull gear racks (12 or 13) out of the housing.
8. Pull gear rack with magnet (65) out of the housing.
9. Pull gear racks (12 or 13) out of the housing.
10. Remove outer safety rings (51) and pull the bearing bushes (74) out of the housing.
11. **Size 32, 42, 52 only:** Remove internal safety rings (51).
12. Remove internal safety rings (51).
13. Pull piston rod (10 or 11) out of the housing.
14. **Size 42, 52 only:** Remove internal safety rings (50).
15. Remove safety rings (50)
16. Pull pistons (9) off the piston rods (10, 11 or 19).

8.5 Servicing and assembling the product

Maintenance

- Clean all parts thoroughly and check for damage and wear.
- Treat all greased areas with lubricant.
 - ▶ 8.3 [34]
- Oil or grease bare external steel parts.
- Replace all wear parts / seals.
 - Position of the wearing parts ▶ 8.7 [37]
 - Seal kit ▶ 1.4 [7]

Assembly

Assembly takes place in the opposite order to disassembly. Observe the following:

- Unless otherwise specified, secure all screws and nuts with Loctite no. 243 and tighten with the appropriate tightening torque.▶ 8.6 [36]

8.6 Screw tightening torques

Position of the item numbers ▶ 8.7 [37]

Size	Item 40	Item 41
22	6.1 Nm	10.0 Nm
32	10.0 Nm	25.0 Nm
42	51.0 Nm	51.0 Nm
52	51.0 Nm	51.0 Nm

Tab.: Tightening torque [Nm]

8.7 Assembly drawing

The following figure is an example image.
It serves for illustration and assignment of the spare parts.
Variations are possible depending on size and variant.

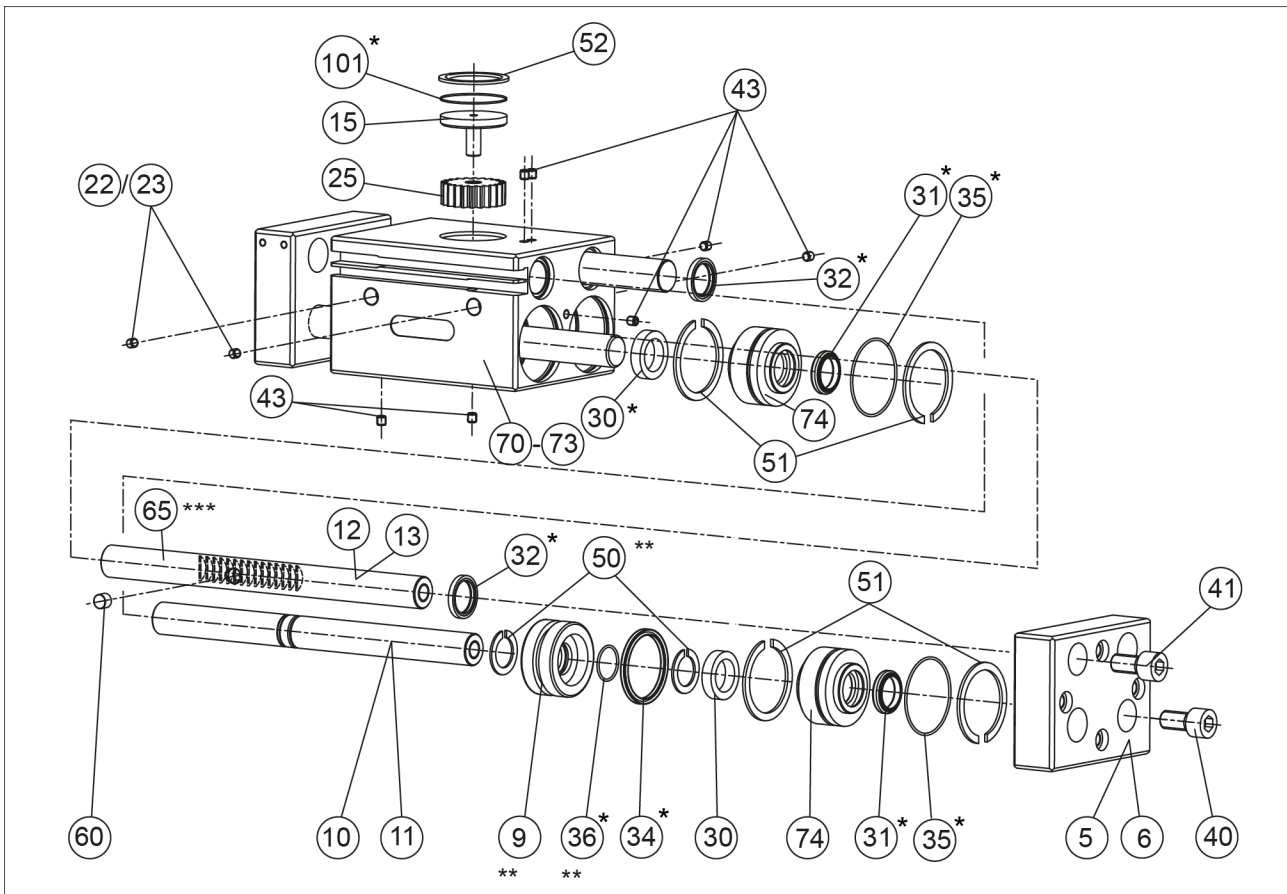

Assembly drawing of gripper

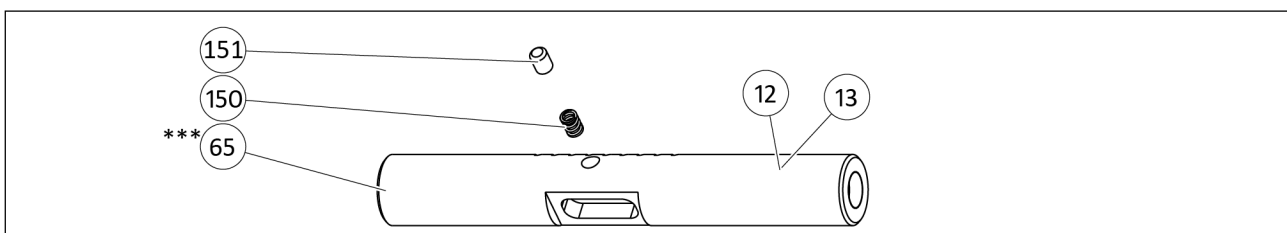

Assembly drawing of gear rack for PSH 22/32-...-EX

- * Wearing part, replace during maintenance.
Included in the seal kit. Seal kit can only be ordered completely.
- ** omitted for Size 22 and 32
- *** for Size 22 and 32

9 Translation of the original declaration of incorporation

in terms of the Directive 2006/42/EG, Annex II, Part 1 Section B.

Manufacturer/
Distributor SCHUNK SE & Co. KG
Spanntechnik | Greiftechnik | Automatisierungstechnik
Bahnhofstr. 106 – 134
D-74348 Lauffen/Neckar

We hereby declare that the partly completed machine described below

Product designation: 2-Finger-Parallel Gripper / PSH /pneumatic
ID number 302122...302123, 302132...302133, 302142...302143, 302146, 302152,
1401308...1401308, 1451061...1451063, 1452071, 1452083...1452084,
39302122...39302123, 39302132...39302133, 39302142...39302143,
39302146, 39302152

meets the following basic occupational health and safety of the Machinery Directive 2006/42/EC:

No. 1.1.1, No. 1.1.2, No. 1.1.3, No. 1.1.5, No. 1.3.2, No. 1.5.3, No. 1.5.4, No. 1.5.6, No. 1.5.8, No. 1.5.10, No. 1.5.11, No. 1.5.13

The partly completed machinery may not be put into operation until it has been confirmed that the machine into which the partly completed machinery is to be installed complies with the provisions of the Machinery Directive (2006/42/EC). The declaration shall be rendered invalid if modifications are made to the product.

Applied harmonized standards, especially:

EN ISO 12100:2010 Safety of machinery – General principles for design –
Risk assessment and risk reduction

The special technical documentation according to Annex VII, Part B, belonging to the partly completed machine, has been created.

Person authorized to compile the technical documentation:
Stefanie Walter, Address: see manufacturer's address

Signature: see original declaration

Lauffen/Neckar, April 2025

Dr.-Ing. Manuel Baumeister,
Head of Systems Engineering,
Technology & Innovation

10 UKCA declaration of incorporation

in accordance with the Supply of Machinery (Safety) Regulations 2008.

Manufacturer/
Distributor SCHUNK Intec Limited
 Clamping and gripping technology
 3 Drakes Mews, Crownhill
 MK8 0ER Milton Keynes

We hereby declare that on the date of the declaration the following partly completed machine complied with all basic safety and health regulations found in the "Supply of Machinery (Safety) Regulations 2008".

The declaration shall be rendered invalid if modifications are made to the product.

Product designation: 2-Finger-Parallel Gripper / PSH / pneumatic
ID number 302122...302123, 302132...302133, 302142...302143, 302146, 302152,
 1401308...1401308, 1451061...1451063, 1452071, 1452083...1452084,
 39302122...39302123, 39302132...39302133, 39302142...39302143,
 39302146, 39302152

The partly completed machine may not be put into operation until it has been confirmed that the machine into which the partly completed machine is to be installed complies with the provisions of the "Supply of Machinery (Safety) Regulations 2008".

Applied harmonized standards, especially:

EN ISO 12100:2010 Safety of machinery – General principles for design –
 Risk assessment and risk reduction

The special technical documentation according to Annex VII, Part B, belonging to the partly completed machine, has been created.

Person authorized to compile the technical documentation:
Marcel Machado, address: refer to manufacturer's address



Dr.-Ing. Manuel Baumeister,
Head of Systems Engineering,
Technology & Innovation

Lauffen/Neckar, April 2025

11 Information on the RoHS Directive, REACH Regulation and Substances of Very High Concern (SVHC)

RoHS Directive

SCHUNK products are classified as "large-scale stationary installations" or as "large-scale stationary industrial tools" within the meaning of Directive 2011/65/EU and its extension 2015/863/EU "on the restriction of the use of certain hazardous substances in electrical and electronic equipment (RoHS)", or fulfill their intended function only as part of one. Therefore products from SCHUNK do not fall within the scope of the directive at this time.

REACH Regulation

Products from SCHUNK fully comply with the regulations of Regulation (EC) No. 1907/2006 "concerning the Registration, Evaluation, Authorization and Restriction of Chemicals (REACH)" and its amendment 2022/477. SCHUNK attaches great importance to completely avoiding chemicals of concern to humans and the environment wherever possible.

Only in rare exceptional cases do SCHUNK products contain SVHC substances on the candidate list with a mass content above 0.1%. In accordance with Article. 33 (1) of Regulation (EC) No. 1907/2006, SCHUNK complies with its duty to "communicate information on substances in articles" and lists the components concerned and the substances used in an overview that can be viewed at schunk.com/SVHC.

Signature: see original declaration

Lauffen/Neckar, April 2025

Dr.-Ing. Manuel Baumeister,
Head of Systems Engineering,
Technology & Innovation

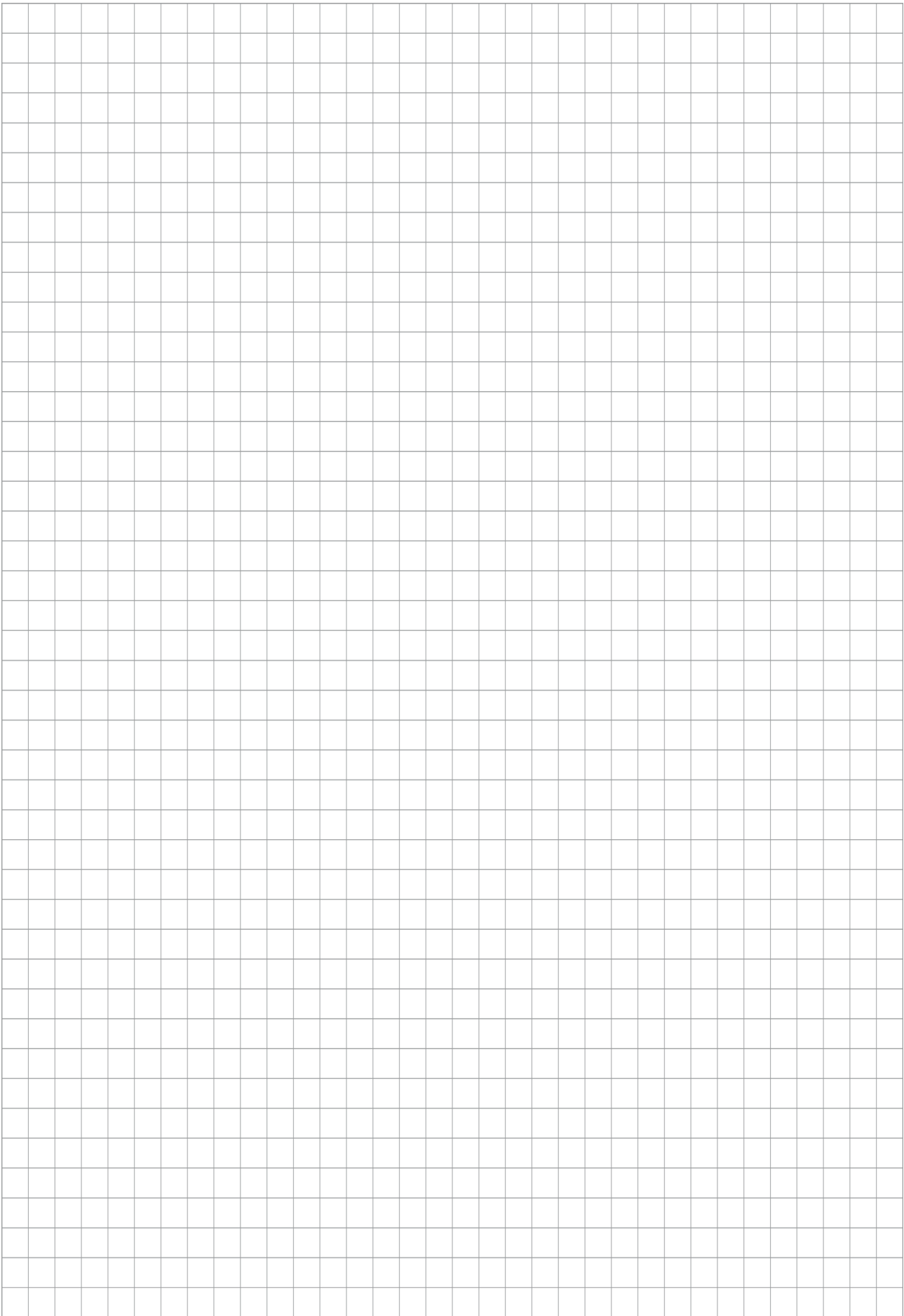







SCHUNK SE & Co. KG
Spanntechnik | Greiftechnik | Automatisierungstechnik

Bahnhofstr. 106 - 134
D-74348 Lauffen/Neckar
Tel. +49-7133-103-0
info@de.schunk.com
schunk.com

Folgen Sie uns | *Follow us*



Wir drucken nachhaltig | *We print sustainable*