



# Assembly and Operating Manual

## PZN-plus

### 3-Finger Centric Gripper

Translation of the original manual

Hand in hand for tomorrow

## Imprint

### Copyright:

This manual is protected by copyright. The author is SCHUNK SE & Co. KG.  
All rights reserved.

### Technical changes:

We reserve the right to make alterations for the purpose of technical improvement.

**Document number:** 389374

**Version:** 22.00 | 31/03/2025 | en

Dear Customer,

Thank you for trusting our products and our family-owned company, the leading technology supplier of robots and production machines.

Our team is always available to answer any questions on this product and other solutions. Ask us questions and challenge us. We will find a solution!

Best regards,

Your SCHUNK team

Customer Management

Tel. +49-7133-103-2503

Fax +49-7133-103-2189

cmg@de.schunk.com



**Please read the operating manual in full and keep it close to the product.**

## Table of Contents

<b>1</b>	<b>General .....</b>	<b>6</b>
1.1	About this manual.....	6
1.1.1	Presentation of Warning Labels .....	6
1.1.2	Definition of Terms .....	7
1.1.3	Applicable documents .....	7
1.1.4	Sizes.....	7
1.1.5	Variants .....	7
1.2	Warranty .....	8
1.3	Scope of delivery.....	8
1.3.1	Accessories kit .....	8
1.4	Accessories .....	9
1.4.1	Sealing kit .....	9
<b>2</b>	<b>Basic safety notes .....</b>	<b>11</b>
2.1	Intended use.....	11
2.2	Constructional changes.....	11
2.3	Spare parts .....	11
2.4	Gripper fingers .....	11
2.5	Ambient conditions and operating conditions .....	12
2.6	Personnel qualification .....	12
2.7	Personal protective equipment .....	13
2.8	Notes on safe operation.....	13
2.9	Transport.....	14
2.10	Malfunctions .....	14
2.11	Disposal .....	14
2.12	Fundamental dangers .....	14
2.12.1	Protection during handling and assembly .....	15
2.12.2	Protection during commissioning and operation .....	15
2.12.3	Protection against dangerous movements .....	15
2.12.4	Protection against electric shock.....	16
2.13	Notes on particular risks .....	17
<b>3</b>	<b>Technical data .....</b>	<b>19</b>
3.1	Name plate .....	19
3.2	Basic data .....	19
<b>4</b>	<b>Design and description .....</b>	<b>21</b>
4.1	Design .....	21
4.2	Description .....	21
<b>5</b>	<b>Assembly.....</b>	<b>22</b>

5.1	Installing and connecting .....	22
5.2	Connections .....	23
5.2.1	Mechanical connection .....	23
5.2.2	Pneumatic connection.....	26
5.3	Mounting the sensor.....	28
5.3.1	Overview of sensors .....	28
5.3.2	Setting dimensions for magnetic switches .....	29
5.3.3	Switch-off hysteresis for magnetic switches .....	30
5.3.4	Turn control cam .....	31
5.3.5	Mounting inductive proximity switch IN 80.....	32
5.3.6	Mounting magnetic switch MMS 22.....	34
5.3.7	Mounting programmable magnetic switch MMS 22-PI2 .....	35
5.3.8	Mounting programmable magnetic switch MMS-P 22.....	36
5.3.9	Mounting programmable magnetic switch MMS 22-PI1.....	37
5.3.10	Mounting the magnetic switch MMS 22-IOL .....	39
5.3.11	Mounting the analog position sensor APS-Z80 .....	42
5.3.12	Mounting reed switch RMS 22.....	44
5.3.13	Mounting the reed switch RMS 80 .....	45
5.3.14	Mounting flexible position sensor FPS.....	47
5.3.15	Mounting the analog position sensor APS-M1 .....	48
5.3.16	Mounting the radio system RSS-R1/T2.....	49
<b>6</b>	<b>Troubleshooting.....</b>	<b>50</b>
6.1	Product is not moving .....	50
6.2	Product is not executing the complete stroke .....	50
6.3	Product opens or closes abruptly .....	50
6.4	Gripping force is dropping.....	51
6.5	Product does not achieve the opening and closing times .....	51
6.6	Programmable magnetic switches not switching as desired .....	51
<b>7</b>	<b>Maintenance .....</b>	<b>52</b>
7.1	Notes.....	52
7.2	Maintenance intervals.....	53
7.3	Lubricants/greasing areas (basic lubrication) .....	54
7.4	Disassembly and assembly .....	55
7.4.1	Variant with dust cover .....	55
7.4.2	Version without gripping force maintenance .....	55
7.4.3	Version with gripping force maintenance O.D. ....	56
7.4.4	Version with gripping force maintenance I.D. ....	59
7.4.5	Version with force amplification cylinder (KVZ).....	61
7.4.6	Notes for assembly .....	63
7.4.7	Screw tightening torques .....	63
7.4.8	Spring force information for assembly .....	63

7.5 Drawings .....	64
7.5.1 Basic module .....	65
7.5.2 Variant with dust cover .....	66
7.5.3 Variant with force amplification cylinder .....	67
<b>8 Translation of the original declaration of incorporation .....</b>	<b>68</b>
<b>9 UKCA declaration of incorporation .....</b>	<b>69</b>

# 1 General

## 1.1 About this manual

This manual contains important information for a safe and appropriate use of the product.

This manual is an integral part of the product and must be kept accessible for the personnel at all times.

Before starting work, the personnel must have read and understood this operating manual. Prerequisite for safe working is the observance of all safety instructions in this manual.

In addition to these instructions, the documents listed under ▶ 1.1.3 [📄 7] are applicable.

**NOTE:** The illustrations in this manual are intended to provide a basic understanding and may deviate from the actual version.

### 1.1.1 Presentation of Warning Labels

To make risks clear, the following signal words and symbols are used for safety notes.



**⚠ DANGER**

**Dangers for persons!**

Non-observance will inevitably cause irreversible injury or death.



**⚠ WARNING**

**Dangers for persons!**

Non-observance can lead to irreversible injury and even death.



**⚠ CAUTION**

**Dangers for persons!**

Non-observance can cause minor injuries.

**NOTICE**

**Material damage!**

Information about avoiding material damage.

### 1.1.2 Definition of Terms

The term "product" replaces the product name on the title page in this manual.

### 1.1.3 Applicable documents

- General terms of business \*
- Catalog data sheet of the purchased product \*
- Assembly and operating manuals of the accessories \*
- For ATEX versions: Supplementary sheet "Installation and operating instructions - EX" \*

The documents labeled with an asterisk (\*) can be downloaded from [schunk.com/downloads](https://www.schunk.com/downloads).

### 1.1.4 Sizes

This operating manual applies to the following sizes:

- PZN-plus 40
- PZN-plus 50
- PZN-plus 64
- PZN-plus 80
- PZN-plus 100
- PZN-plus 125
- PZN-plus 160
- PZN-plus 200
- PZN-plus 240
- PZN-plus 300
- PZN-plus 380

### 1.1.5 Variants

This operating manual applies to the following variations:

- PZN-plus
- PZN-plus with gripping force maintenance O.D. gripping
- PZN-plus with gripping force maintenance I.D. gripping
- PZN-plus Anti-corrosion version
- PZN-plus high-temperature (V/HT)
- PZN-plus Force intensified version (KVZ)
- PZN-plus Dust-tight
- PZN-plus Precision version
- PZN-plus ATEX (EX)

## 1.2 Warranty

If the product is used as intended, the warranty is valid for 36 months from the ex-works delivery date under the following conditions:

- Observe the specified maintenance and lubrication intervals
- Observe the ambient conditions and operating conditions

Parts touching the workpiece and wear parts are not included in the warranty.

## 1.3 Scope of delivery

The scope of delivery includes

- 3-Finger Centric Gripper PZN-plus in the version ordered
- Safety information (product-specific instructions available online)
- Accessory pack

### 1.3.1 Accessories kit

Content of the accessory pack:

- 6 x Centering sleeves for mounting
- 2 x O-ring for hose-free direct connection
- 2 x screw plug for hose connection
- 2 x Cylindrical pin

ID.-No. of the accessory pack:

Size	ID number
40	5521694
50	5520796
64	5512728
80	5512729
100	5512730
125	5512731
160	5512732
200	5512733
240	5514005
300	5514240
380	5520730
high-temperature (V/HT)	
40	5521695
50	5520797
64	395512728

Size	ID number
80	395512729
100	395512730
125	395512731
160	395512732
200	395512733
240	395514005
300	395514240
380	1343258

Tab.: ID.-No. of the accessory pack

## 1.4 Accessories

A wide range of accessories are available for this product

For information regarding which accessory articles can be used with the corresponding product variants, see catalog data sheet.

### 1.4.1 Sealing kit

contents of the sealing kit, ► 7.5 [ 64].

Size	ID number
40	5516815
50	5516816
64	0303450
80	0303451
100	0303452
125	0303453
160	0303454
200	0303455
240	0303456
300	0303457
380	0303458
high-temperature (V/HT)	
40	395516815
50	395516816
64	39303450
80	39303451
100	39303452
125	39303453
160	39303454
200	39303455

Size	ID number
240	39303456
300	39303457
380	39303458
Dust-tight	
40	5518720
50	5518721
64	5518722
80	5518723
100	5518724
125	5518725
160	5518726
200	5518727
240	5518728
300	5518729
380	5522513
Force intensified version (KVZ)	
40	-
50	-
64	5515869
80	5515870
100	5515871
125	5515872
160	5515873
200	-
240	-
300	-
380	-

Tab.: ID.-No. of the accessory pack

## 2 Basic safety notes

### 2.1 Intended use

The product is designed exclusively for gripping and temporarily holding workpieces or objects.

- The product may only be used within the scope of its technical data, ▶ 3 [19].
- The product is intended for installation in a machine/ automated system. The applicable guidelines for the machine/ automated system must be observed and complied with.
- The product is intended for industrial and industry-oriented use. Its use outside enclosed spaces is only permitted if suitable protective measures are taken against outdoor exposure. The product is not suitable for use in salty air.
- The product can be used within the permissible load limits and technical data for holding workpieces during simple machining operations, but is not a clamping device according to EN 1550:1997+A1:2008.
- Appropriate use of the product includes compliance with all instructions in this manual.
- Any utilization that exceeds or differs from the appropriate use is regarded as misuse.

### 2.2 Constructional changes

#### Implementation of structural changes

Modifications, changes or reworking, e.g. additional threads, holes, or safety devices, can damage the product or impair its functionality or safety.

- Structural changes should only be made with the written approval of SCHUNK.

### 2.3 Spare parts

#### Use of unauthorized spare parts

Using unauthorized spare parts can endanger personnel and damage the product or cause it to malfunction.

- Use only original spare parts or spares authorized by SCHUNK.

### 2.4 Gripper fingers

#### Requirements of gripper fingers

Accumulated energy can make the product unsafe and risk the danger of serious injuries and considerable material damage.

- Execute the gripper fingers in such a way that the product reaches either the "open" or "closed" position in a de-energized state.
- Only change gripper fingers if no residual energy can be released.
- Make sure that the product and the top jaws are a sufficient size for the application.

## 2.5 Ambient conditions and operating conditions

### Required ambient conditions and operating conditions

Incorrect ambient and operating conditions can make the product unsafe, leading to the risk of serious injuries, considerable material damage and/or a significant reduction to the product's life span.

- Make sure that the product is used only in the context of its defined application parameters, ▶ 3 [📄 19].

## 2.6 Personnel qualification

### Inadequate qualifications of the personnel

If the personnel working with the product is not sufficiently qualified, the result may be serious injuries and significant property damage.

- All work may only be performed by qualified personnel.
- Before working with the product, the personnel must have read and understood the complete assembly and operating manual.
- Observe the national safety regulations and rules and general safety instructions.

The following personal qualifications are necessary for the various activities related to the product:

#### Trained electrician

Due to their technical training, knowledge and experience, trained electricians are able to work on electrical systems, recognize and avoid possible dangers and know the relevant standards and regulations.

#### Qualified personnel

Due to its technical training, knowledge and experience, qualified personnel is able to perform the delegated tasks, recognize and avoid possible dangers and knows the relevant standards and regulations.

#### Instructed person

Instructed persons were instructed by the operator about the delegated tasks and possible dangers due to improper behaviour.

**Service personnel of the manufacturer** Due to its technical training, knowledge and experience, service personnel of the manufacturer is able to perform the delegated tasks and to recognize and avoid possible dangers.

## 2.7 Personal protective equipment

### Use of personal protective equipment

Personal protective equipment serves to protect staff against danger which may interfere with their health or safety at work.

- When working on and with the product, observe the occupational health and safety regulations and wear the required personal protective equipment.
- Observe the valid safety and accident prevention regulations.
- Wear protective gloves to guard against sharp edges and corners or rough surfaces.
- Wear heat-resistant protective gloves when handling hot surfaces.
- Wear protective gloves and safety goggles when handling hazardous substances.
- Wear close-fitting protective clothing and also wear long hair in a hairnet when dealing with moving components.

## 2.8 Notes on safe operation

### Incorrect handling of the personnel

Incorrect handling and assembly may impair the product's safety and cause serious injuries and considerable material damage.

- Avoid any manner of working that may interfere with the function and operational safety of the product.
- Use the product as intended.
- Observe the safety notes and assembly instructions.
- Do not expose the product to any corrosive media. This does not apply to products that are designed for special environments.
- Eliminate any malfunction immediately.
- Observe the care and maintenance instructions.
- Observe the current safety, accident prevention and environmental protection regulations regarding the product's application field.

## 2.9 Transport

### Handling during transport

Incorrect handling during transport may impair the product's safety and cause serious injuries and considerable material damage.

- When handling heavy weights, use lifting equipment to lift the product and transport it by appropriate means.
- Secure the product against falling during transportation and handling.
- Stand clear of suspended loads.

## 2.10 Malfunctions

### Behavior in case of malfunctions

- Immediately remove the product from operation and report the malfunction to the responsible departments/persons.
- Order appropriately trained personnel to rectify the malfunction.
- Do not recommission the product until the malfunction has been rectified.
- Test the product after a malfunction to establish whether it still functions properly and no increased risks have arisen.

## 2.11 Disposal

### Handling of disposal

The incorrect handling of disposal may impair the product's safety and cause serious injuries as well as considerable material and environmental harm.

- Follow local regulations on dispatching product components for recycling or proper disposal.

## 2.12 Fundamental dangers

### General

- Observe safety distances.
- Never deactivate safety devices.
- Before commissioning the product, take appropriate protective measures to secure the danger zone.
- Disconnect power sources before installation, modification, maintenance, or calibration. Ensure that no residual energy remains in the system.
- If the energy supply is connected, do not move any parts by hand.

- Do not reach into the open mechanism or movement area of the product during operation.

### 2.12.1 Protection during handling and assembly

#### Incorrect handling and assembly

Incorrect handling and assembly may impair the product's safety and cause serious injuries and considerable material damage.

- Have all work carried out by appropriately qualified personnel.
- For all work, secure the product against accidental operation.
- Observe the relevant accident prevention rules.
- Use suitable assembly and transport equipment and take precautions to prevent jamming and crushing.

#### Incorrect lifting of loads

Falling loads may cause serious injuries and even death.

- Stand clear of suspended loads and do not step into their swiveling range.
- Never move loads without supervision.
- Do not leave suspended loads unattended.

### 2.12.2 Protection during commissioning and operation

#### Falling or violently ejected components

Falling and violently ejected components can cause serious injuries and even death.

- Take appropriate protective measures to secure the danger zone.
- Never step into the danger zone during operation.

### 2.12.3 Protection against dangerous movements

#### Unexpected movements

Residual energy in the system may cause serious injuries while working with the product.

- Switch off the energy supply, ensure that no residual energy remains and secure against inadvertent reactivation.
- Never rely solely on the response of the monitoring function to avert danger. Until the installed monitors become effective, it must be assumed that the drive movement is faulty, with its action being dependent on the control unit and the current operating condition of the drive. Perform maintenance work, modifications, and attachments outside the danger zone defined by the movement range.

- To avoid accidents and/or material damage, human access to the movement range of the machine must be restricted. Limit/prevent accidental access for people in this area due through technical safety measures. The protective cover and protective fence must be rigid enough to withstand the maximum possible movement energy. EMERGENCY STOP switches must be easily and quickly accessible. Before starting up the machine or automated system, check that the EMERGENCY STOP system is working. Prevent operation of the machine if this protective equipment does not function correctly.

#### **2.12.4 Protection against electric shock**

##### **Possible electrostatic energy**

Components or assembly groups may become electrostatically charged. When the electrostatic charge is touched, the discharge may trigger a shock reaction leading to injuries.

- The operator must ensure that all components and assembly groups are included in the local potential equalisation in accordance with the applicable regulations.
- While paying attention to the actual conditions of the working environment, the potential equalisation must be implemented by a specialist electrician according to the applicable regulations.
- The effectiveness of the potential equalisation must be verified by executing regular safety measurements.

## 2.13 Notes on particular risks



### **⚠ DANGER**

#### **Risk of fatal injury from suspended loads!**

Falling loads can cause serious injuries and even death.

- Stand clear of suspended loads and do not step within their swiveling range.
- Never move loads without supervision.
- Do not leave suspended loads unattended.
- Wear suitable protective equipment.



### **⚠ WARNING**

#### **Risk of injury from objects falling and being ejected!**

Falling and ejected objects during operation can lead to serious injury or death.

- Take appropriate protective measures to secure the danger zone.



### **⚠ WARNING**

#### **Risk of injury from sharp edges and corners!**

Sharp edges and corners can cause cuts.

- Use suitable protective equipment.



### **⚠ WARNING**

#### **Risk of injury due to unexpected movements!**

If the power supply is switched on or residual energy remains in the system, components can move unexpectedly and cause serious injuries.

- Before starting any work on the product: Switch off the power supply and secure against restarting.
- Make sure, that no residual energy remains in the system.



**⚠ WARNING**

**Risk of injury from crushing and impacts!**

Serious injury could occur during movement of the base jaw, due to breakage or loosening of the gripper fingers or if the workpiece is lost.

- Wear suitable protective equipment.
- Do not reach into the open mechanism or the movement area of the product.



**⚠ WARNING**

**Risk of injury due to spring forces!**

Parts are under spring tension on products which clamp using spring force or which have gripping force maintenance. While disassembling components can move unexpectedly and cause serious injuries.

- Disassemble the product cautiously.
- Make sure that no residual energy remains in the system.



**⚠ WARNING**

**Risk of injury from objects falling during energy supply failure**

Products with a mechanical gripping force maintenance can, during energy supply failure, still move independently in the direction specified by the mechanical gripping force maintenance.

- Secure the end positions of the product with SCHUNK SDV-P pressure maintenance valves.

### 3 Technical data

#### 3.1 Name plate

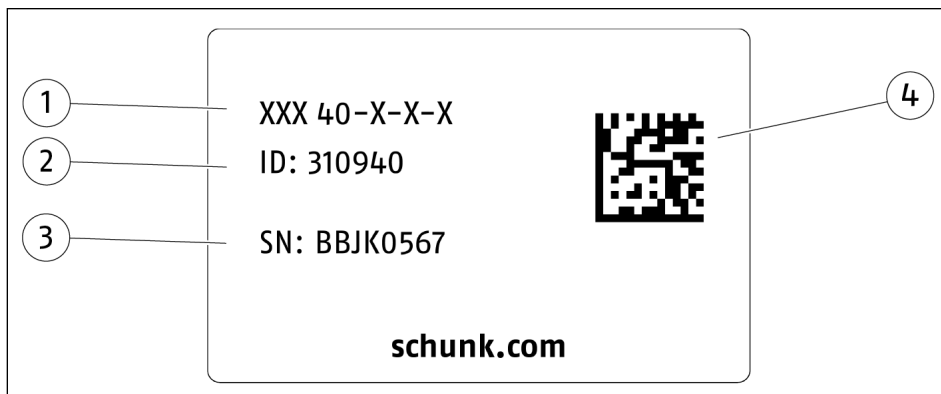

- 1 Product designation

---

- 2 ID

---

- 3 Serial number

---

- 4 Data matrix code

Scan code or enter serial number on the web and get all the product information: operating manuals, spare parts packages, software updates and much more.

For further information, visit [schunk.com/serialisierung](https://schunk.com/serialisierung)

A separate app may be required for scanning with a mobile phone.

#### 3.2 Basic data

Designation	Value
Pressure medium	Compressed air, compressed air quality according to ISO 8573-1:2010 [7:4:4]
Nominal operating pressure [bar]	6
Minimum pressure [bar] without maintenance of gripping force	2.5
Minimum pressure [bar] with maintenance of gripping force	4
Maximum pressure [bar] without maintenance of gripping force	8
Maximum pressure [bar] with maintenance of gripping force	6.5

<b>Designation</b>	<b>Value</b>
Maximum pressure [bar] with force intensified cylinder	6
Pressure range for air purge [bar]	0.5 – 1
<b>Ambient conditions and operating conditions</b>	
Ambient temperature [°C] min.	+5
Ambient temperature [°C] max.	+90
Ambient temperature [°C] max. (variant V/HT)	+130
IP rating*	40
IP rating (variant SD)	64
Noise emission [dB(A)]	≤70

\* For use in dirty ambient conditions (e.g. sprayed water, vapors, abrasion or processing dust) SCHUNK offers corresponding product options as standard. SCHUNK also offers customized solutions for special applications in dirty ambient conditions.

More technical data is included in the catalog data sheet.  
Whichever is the latest version.

## 4 Design and description

### 4.1 Design

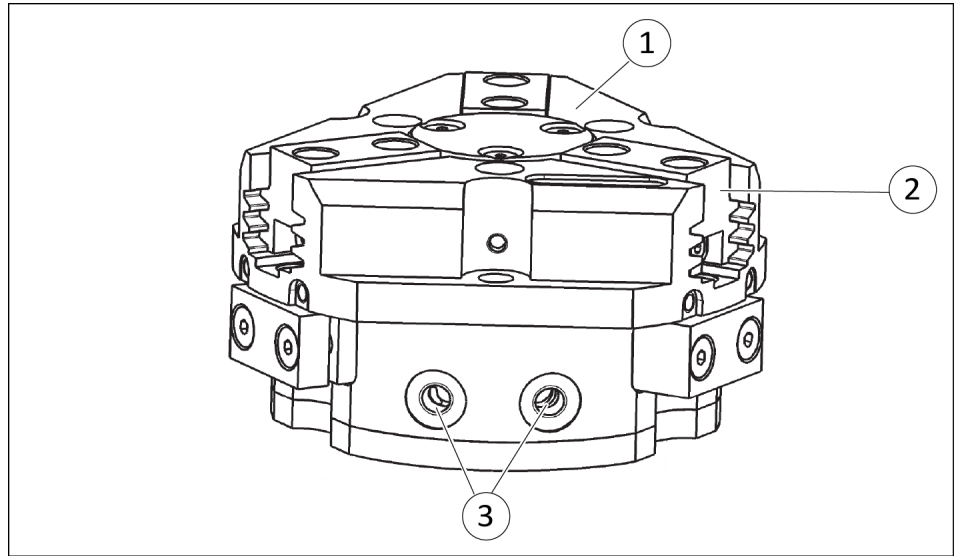

*3-Finger Centric Gripper*

- |   |                                |
|---|--------------------------------|
| 1 | Housing                        |
| 2 | Base jaw                       |
| 3 | Compressed air main connection |

### 4.2 Description

Universal 3-finger centric gripper with high gripping force and high maximum moments due to multi-tooth guidance.

## 5 Assembly

### 5.1 Installing and connecting



#### **⚠ DANGER**

##### **Danger of explosion in potentially explosive areas!**

- Observe supplementary sheet for products with explosion-resistant versions "PZN-plus -...-EX".



#### **⚠ WARNING**

##### **Risk of injury due to unexpected movements!**

If the power supply is switched on or residual energy remains in the system, components can move unexpectedly and cause serious injuries.

- Before starting any work on the product: Switch off the power supply and secure against restarting.
- Make sure, that no residual energy remains in the system.

#### **NOTICE**

##### **Damage to the gripper is possible!**

If the maximum permissible finger weight or the permissible mass moment of inertia of the fingers is exceeded, the gripper can be damaged.

- A jaw movement always has to be without jerks and bounce.
- You must therefore implement sufficient reduction and/or damping.
- Observe the information in the catalog data sheet.

1. Check the evenness of the mounting surface, ▶ 5.2.1 [ 23].
2. Only open the required air connections (main connection or direct connection), ▶ 5.2.2 [ 26].
3. Connect the product via the hose-free direct connection.
  - ⇒ Use O-rings from the accessory pack.
  - ⇒ Seal main air connections which are not required with locking screws.
4. OR: Connect compressed air lines to the main air connections "A" and "B".
  - ⇒ Screw in air connections (plug connections).  
OR: Screw on throttle valve in order to be able to perform sufficient throttling and/or damping.
5. Screw the product to the machine/system, ▶ 5.2.1 [ 23].

- ⇒ When mounting from the rear: use cylindrical pins for fixing the product in place.
  - ⇒ If necessary, use appropriate connection elements (adapter plates).
  - ⇒ Observe requirements for the adapter plate, ▶ 5.2.1 [24].
  - ⇒ Observe the maximal tightening torque, admissible screw-in depth and, if necessary, strength class.
6. Secure the gripper fingers to the base jaws, ▶ 5.2.1 [23].
    - ⇒ Use centering sleeves from the enclosed accessory pack.
  7. If necessary, fit a pressure piece for spring-supported positioning of the workpiece against a stop, ▶ 5.2.1.1 [26].
  8. Connect the sensor, see assembly and operating manual of the sensor.
  9. Mount the sensor, ▶ 5.3 [28].

## 5.2 Connections

### 5.2.1 Mechanical connection

Evenness of the mounting surface

The values apply to the whole mounting surface to which the product is mounted.

Edge length	Permissible unevenness
< 100	< 0.02
> 100	< 0.05

Tab.: Requirements for evenness of the mounting surface (Dimensions in mm)

Connections at the base jaws

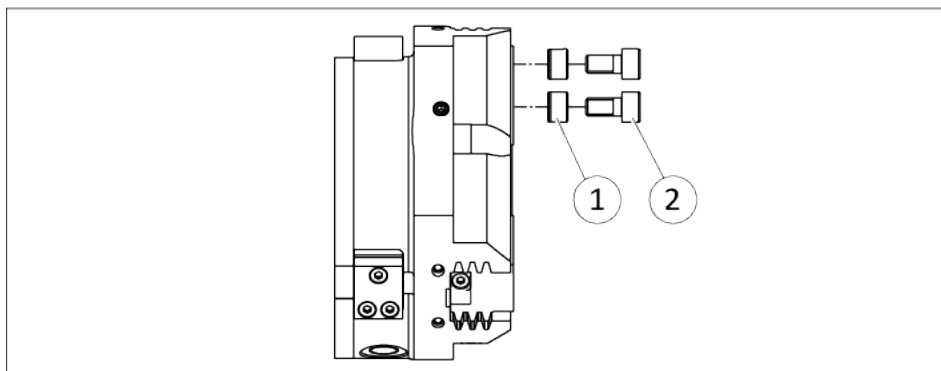

Size	① Centering sleeve	② Screws *
40	Ø4	M2.5 / 6
50	Ø5	M3 / 8
64	Ø6	M4 / 10
80	Ø8	M5 / 10
100	Ø10	M6 / 13
125	Ø10	M6 / 13

**Requirements for customer adapter plates**

Size	① Centering sleeve	② Screws *
160	Ø14	M10 / 17
200	Ø16	M12 / 17
240	Ø16	M12 / 20
300	Ø22	M16 / 26
380	Ø28	M20 / 30

\* Thread / max. depth of engagement from locating surface [mm]

If the adapter plate has bores or recesses and therefore the product is not fully flush, the minimum support surface must be adhered to. The recess/bore in the adapter plate may not exceed the dimension "A"; for dimensions, see the following table.

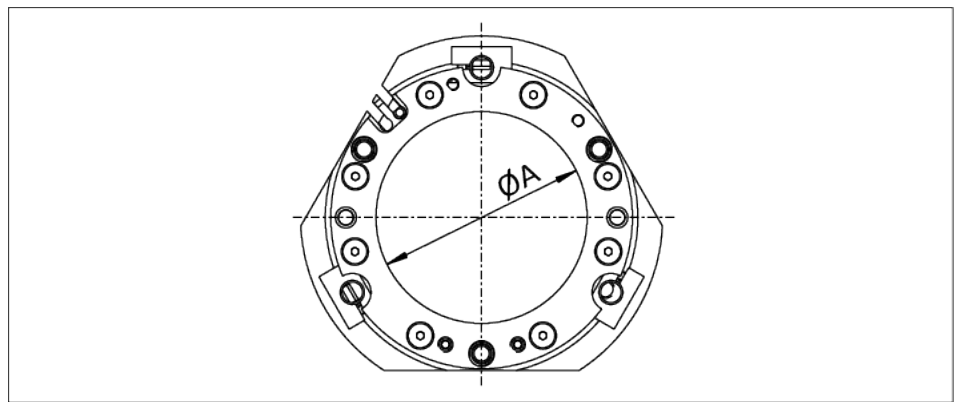

Size	Max. recess "A" [mm]
40	Ø24
50	Ø32
64	Ø40
80	Ø55
100	Ø70
125	Ø85
160	Ø115
200	Ø150
240	Ø196
300	Ø236
380	Ø292

## Connections at the housing

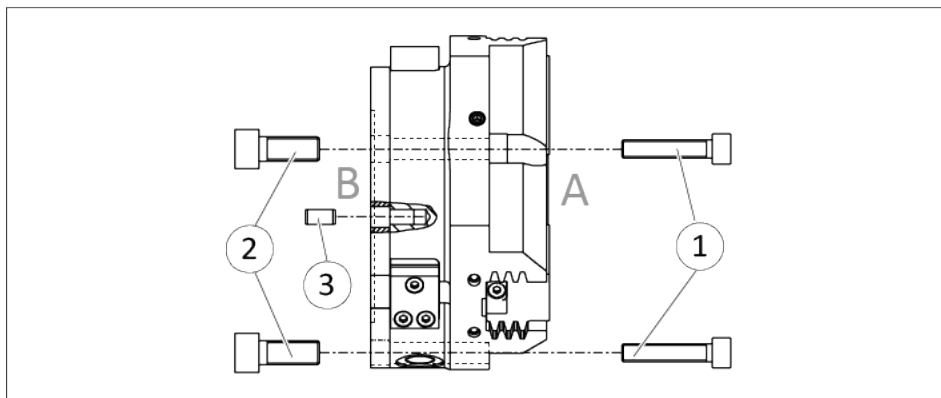

Assembly options

The product can be assembled from two sides.

Size	side A		side B
	① Screws	② Screws *	③ Fitting bore for centering pin [mm]
40	M3	-	∅2
50	M3	M4 / 10	∅3
50 (AS / IS)	M3	M4 / 20.5	∅3
64	M5	M6 / 13	∅4
64 (AS / IS)	M5	M6 / 26	∅4
80	M6	M8 / 17	∅5
80 (AS / IS)	M6	M8 / 32	∅5
100	M6	M8 / 18	∅5
100 (AS / IS)	M6	M8 / 38	∅5
125	M8	M10 / 21	∅6
125 (AS / IS)	M8	M10 / 45.5	∅6
160	M8	M10 / 21.5	∅6
160 (AS / IS)	M8	M10 / 51.5	∅6
200	M10	M12 / 25	∅8
200 (AS / IS)	M10	M12 / 61	∅8
240	M12	-	∅8
300	M16	-	∅10
380	M20	-	∅12

\* Thread / max. depth of engagement from locating surface [mm]

### 5.2.1.1 Mounting of the gripper by using a spring loaded pressure-piece



#### ⚠ CAUTION

**The spring-loaded pressure piece is under spring tension.**

The pressure piece can fly out in an uncontrolled fashion and cause contusions.

- During assembly or disassembly, be especially careful with the springs.

When mounting the gripper from the side of the gripper fingers, the assembly of the pressure piece must be done **after** the mounting of the gripper.

Mounting the pressure piece is described in the insert "Installation instructions - pressure piece", which is included in the pressure piece's scope of delivery.

### 5.2.2 Pneumatic connection

#### NOTE

- Observe the requirements for the compressed air supply, ▶ 3 [19].
- In case of compressed air loss (cutting off the energy line), the components lose their dynamic effects and do not remain in a secure position. However, the use of a SDV-P pressure maintenance valve is recommended in this case in order to maintain the dynamic effect for some time. Product variants are also offered with mechanical gripping force via springs, which also ensure a minimum clamping force in the event of a pressure drop.

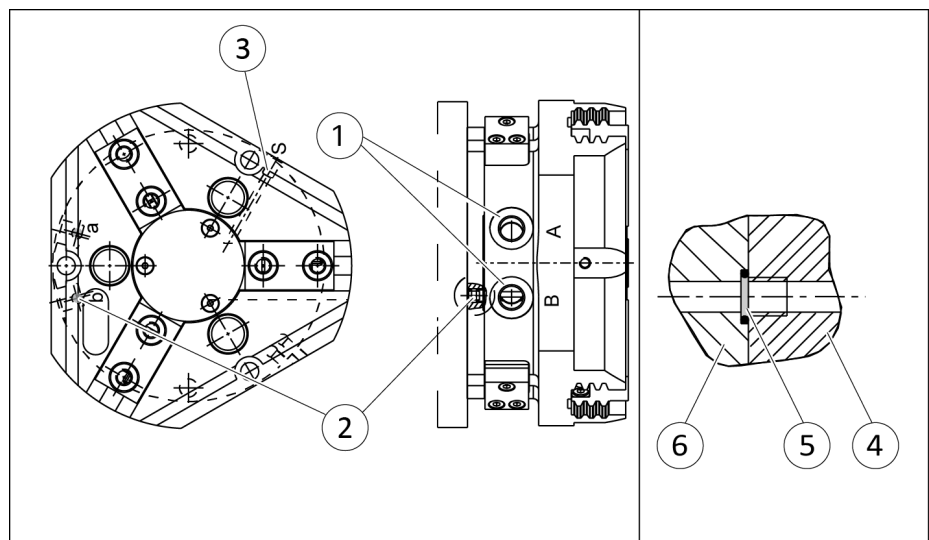

*Air connections*

- 1 Main connections (Hose connection)  
(A = open, B = close)

---

- 2 Hose-free direct connection  
(a = open, b = close)

---

- 3 Air purge connection

---

- Hose-free direct connection

---

- 4 Product

---

- 5 O-ring

---

- 6 Attachment

---

Size	Main air connections	Hose-free direct connection	Air purge connection
40	M3	M3	M3
50	M5	M3	M5
64	M5	M4	M5
80	M5	M4	M5
100	G1/8"	M5	M5
125	G1/8"	M5	M5
160	G1/8"	M4	M5
200	G1/8"	M5	M5
240	G1/4"	M5	M5
300	G1/4"	M8	M5
380	G1/4"	M8	M5

Tab.: Thread diameter of the air connections

### 5.3 Mounting the sensor

#### NOTE

Observe the assembly and operating manual of the sensor for mounting and connecting.

The product is prepared for the use of sensors.

- For the exact type designations of suitable sensors, please see catalog datasheet and ▶ 5.3.1 [📄 28].
- For technical data for the suitable sensors, see assembly and operating manual and catalog datasheet.
  - The assembly and operating manual and catalog datasheet are included in the scope of delivery for the sensors and are available at schunk.com.
- Information on handling sensors is available at schunk.com or from SCHUNK contact persons.

#### 5.3.1 Overview of sensors

PZN-plus	IN 80	MMS 22	MMS 22-PI2	MMS-P 22	MMS 22-PI1	MMS 22-IOL	APS-Z80	RMS 22	RMS 80	FPS-F5 / FPS-S M8	APS-M1	RSS R1/T2 / RMS 80
40	⊘	✓	✓	✓	✓	⊘	⊘	⊘	⊘	⊘	⊘	⊘
50	⊘	✓	✓	✓	✓	⊘	⊘	⊘	⊘	⊘	⊘	⊘
64	✓	✓	✓	✓	✓	✓	✓	⊘	✓	✓	✓	✓
80	✓	✓	✓	✓	✓	✓	✓	⊘	✓	✓	✓	✓
100	✓	✓	✓	✓	✓	✓	✓	✓	✓	✓	✓	✓
125	✓	✓	✓	✓	✓	✓	✓	✓	✓	✓	✓	✓
160	✓	✓	✓	✓	✓	✓	✓	⊘	✓	✓	✓	✓
200	✓	✓	⊘	⊘	✓	⊘	✓	⊘	✓	✓	✓	✓
240	✓	✓	⊘	⊘	✓	⊘	✓	⊘	✓	✓	✓	✓
300	✓	✓	⊘	⊘	✓	⊘	✓	⊘	✓	✓	✓	✓
380	✓	✓	⊘	⊘	✓	⊘	✓	⊘	✓	⊘	✓	✓

### 5.3.2 Setting dimensions for magnetic switches

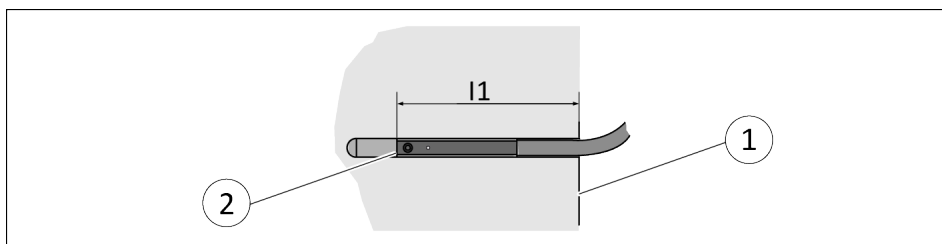

\* Setting dimension  $l_1$ , from product bottom edge (1) to front sensor (2)

The setting dimension applies for the following sensors:

- Programmable magnetic switch MMS 22-PI1
- Programmable magnetic switch MMS 22-PI2
- Programmable magnetic switch MMS-P 22

Size	$l_1^*$ [mm]
40	20.3
40 AS	28.2
40 IS	28.3
40-KVZ	34.8
40 AS-KVZ	42.8
40 IS-KVZ	42.8
50	21.7
50 AS	32.2
50 IS	32.2
50-KVZ	39.7
50 AS-KVZ	50.1
50 IS-KVZ	50.1
64	24.5
64 AS	38.0
64 IS	38.0
64-KVZ	45.5
64 AS-KVZ	59.0
64 IS-KVZ	59.0
80	26.9
80 AS	42.3
80 IS	42.3
80-KVZ	51.9
80 AS-KVZ	66.9
80 IS-KVZ	66.9
100	29.8
100 AS	49.9

Size	l1* [mm]
100 IS	49.9
100-KVZ	59.8
100 AS-KVZ	79.8
100 IS-KVZ	79.8
125	32.5
125 AS	56.9
125 IS	56.9
125-KVZ	67.5
125 AS-KVZ	92.0
125 IS-KVZ	92.0
160	42
160 AS	71.5
160 IS	72.5
160-KVZ	82
160 AS-KVZ	111.5
160 IS-KVZ	112.5

Tab.: Setting dimensions

**NOTE**

The magnetic switch MMS 22-PI1 can be adjusted and taught in two ways.

- "Standard mode" allows for quick installation on the T-nut preset by SCHUNK in the groove or the defined setting dimension "l1."
- In "Optimal Mode", the sensor identifies the optimal position in the groove itself.  
SCHUNK recommends "Optimal Mode" for setting the sensors.

Further information on the installation of the sensor, ▶ 5.3.9 [📄 37]

**5.3.3 Switch-off hysteresis for magnetic switches**

**Sensors MMS 22, MMS 22-PI1, MMS 22-PI2 and MMS-P 22**

The smallest detectable difference in stroke is defined in the following table:

For products with X mm nominal stroke per jaw	Min. query range per jaw/ min. queried stroke difference per jaw
X ≤ 5 mm	30 % of the nominal stroke per jaw
X > 5 mm to X ≤ 10 mm	20 % of the nominal stroke per jaw

For products with X mm nominal stroke per jaw	Min. query range per jaw/ min. queried stroke difference per jaw
X > 10 mm	10 % of the nominal stroke per jaw

Tab.: The smallest detectable difference in stroke based on the nominal stroke

**Example:** Product with 7 mm nominal stroke per jaw

$$7 \text{ mm} * 20\% = 1.4 \text{ mm}$$

### 5.3.4 Turn control cam

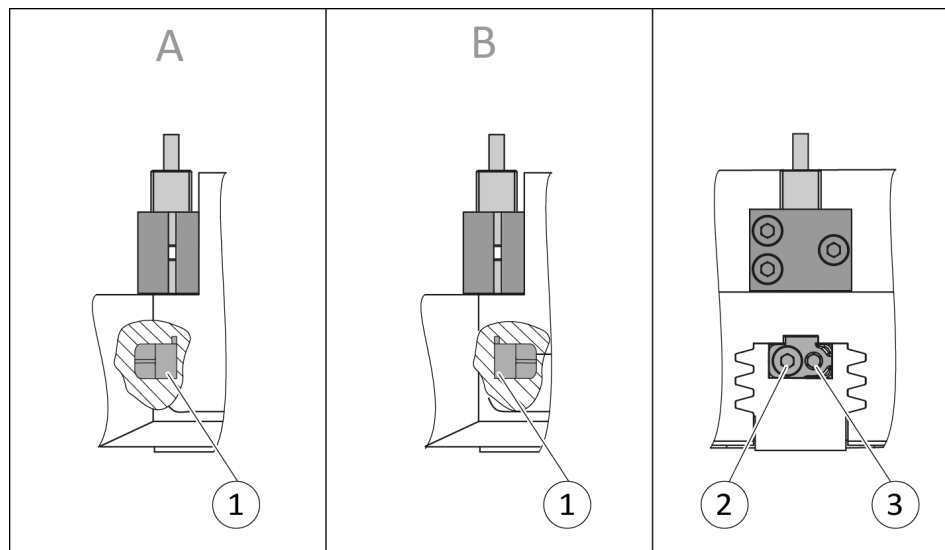

Turn control cam, example control cam for inductive monitoring

Depending on the jaw stroke, it may be necessary to change the alignment of the control cam for the sensors IN 80 and RMS 80.

In the image, the installation situation (A) shows the control cam in the delivery state of the product and the installation situation (B) shows the turned control cam.

In order to change the alignment of the control cam, proceed as follows:

1. Undo the screw (2).
2. Remove control cam (1) from the product, turn and re-insert it into the product.
3. Turn the screw (3) to push the position of the control cam (1).

### 5.3.5 Mounting inductive proximity switch IN 80

#### NOTICE

#### Blockade of the gripper after setting or replacing of the switching cam!

The switching cam can be tilt in the guide, if it was not fixed exactly in the base jaw.

- Apply the switching cam in the direction of the base jaw, so that the cam does not contact the housing of the gripper.

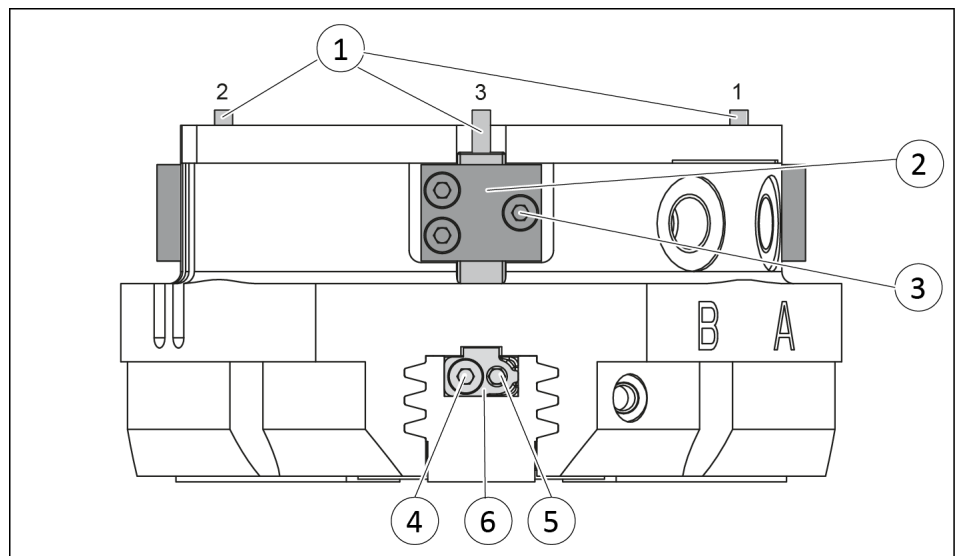

#### NOTE

The screws (4) and (5) differ in length. With size 380, these screws on sensor 3 (1) are the same length.

#### Variant Dust-tight:

Before attaching the sensor, remove the sealing bolts from the bracket. Before adjusting the control cam, unscrew the set-screw from the side cover.

#### Position "Gripper open" or "Part gripped (I.D. gripping)"

1. Slide the sensor 1 (1) or sensor 2 (1) to the stop into the bracket (2).
2. Tighten the screw (3) on the bracket (2).  
Tightening torque: 0.2 Nm
3. Open gripper or grip part.
4. Undo the screw (4).
5. Turn the screw (5) to push the position of the control cam (6).

- ⇒ Slide control cam (6) inwards until the sensor 1 (1) no longer responds.  
Move the control cam (6) back towards the outside until the sensor 1 (1) begins to switch.
- 6. Tighten screw (4) and in doing so press the control cam in the direction of the gripper fingers. **NOTICE! The control cam may tilt in the guide if it has not been tightened properly.**
  - ⇒ Switching point is set.
- 7. Bring product into the "Gripper open" or "Part gripped" position and test the function.

**NOTE**

If the switching position cannot be queried, it may be that the alignment of the control cam has to be changed, ▶ 5.3.4 [ 31].

**Position "Gripper closed" or "Part gripped (O.D. gripping)"**

1. Slide the sensor 3 (1) to the stop into the bracket (2).
2. Tighten the screw (3) on the bracket (2).  
Tightening torque: 0.2 Nm
3. Close gripper or grip part.
4. Undo the screw (4).
5. Turn the screw (5) to push the position of the control cam (6).
  - ⇒ Slide control cam (6) outwards until the sensor 3 (1) no longer responds.  
Move the control cam (6) back towards the inside until the sensor 3 (1) begins to switch.
6. Tighten screw (4) and in doing so press the control cam in the direction of the gripper fingers. **NOTICE! The control cam may tilt in the guide if it has not been tightened properly.**
  - ⇒ Switching point is set.
7. Bring product into the "Gripper closed" or "Part gripped" position and test the function.

**NOTE**

If the switching position cannot be queried, it may be that the alignment of the control cam has to be changed, ▶ 5.3.4 [ 31].

**Variant Dust-tight:**

Screw in set-screw into the side cover.

### 5.3.6 Mounting magnetic switch MMS 22

#### NOTICE

#### Risk of damage to the sensor during assembly!

- Observe the maximal tightening torque.

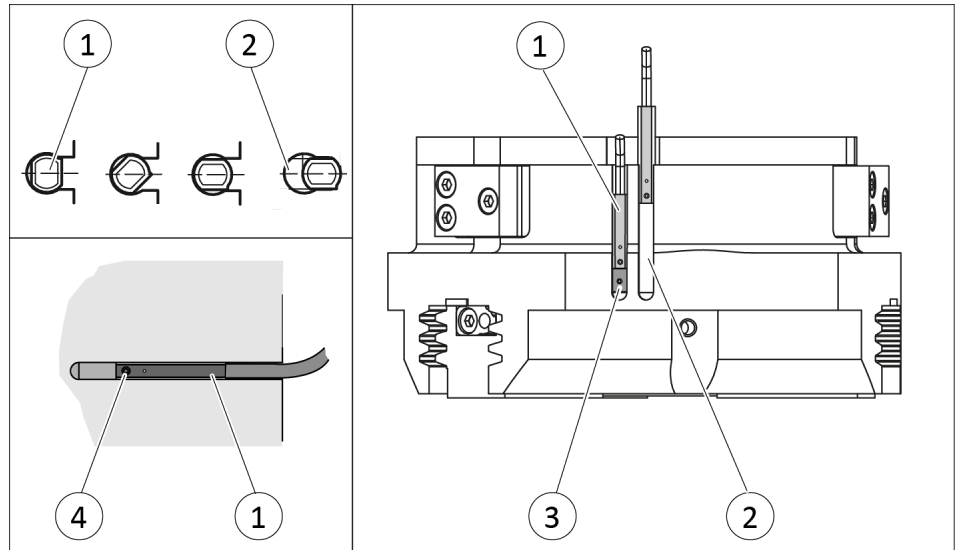

Positioning the magnetic switches

#### Position "Gripper open" or "Part gripped (I.D. gripping)"

1. Bring product in the position to be set.
2. If necessary remove T-nut (3).
3. Turn the sensor 1 (1) into the groove (2).  
OR: Slide the sensor 1 (1) into the groove (2) until the sensor 1 (1) stops at the end of the groove.
4. Pull the sensor 1 (1) back again slowly until it switches.
5. Secure the sensor 1 (1) using the set-screw (4).  
Tightening torque: 10 Ncm
6. Bring product into the "Gripper open" or "Part gripped" position and test the function.

#### Position "Gripper closed" or "Part gripped (O.D. gripping)"

1. Bring product in the position in which it is to be set.
2. If necessary remove T-nut (3).
3. Turn the sensor 2 (1) into the groove (2).  
OR: Slide sensor 2 (1) into the groove (2) in the direction of the housing middle (3), until the sensor 2 (1) switches.
4. Secure the sensor 2 (1) using the set-screw (4).  
Tightening torque: 10 Ncm
5. Bring product into the "Gripper closed" or "Part gripped" position and test the function.

### 5.3.7 Mounting programmable magnetic switch MMS 22-PI2

#### NOTICE

#### Risk of damage to the sensor during assembly!

- Observe the maximal tightening torque.

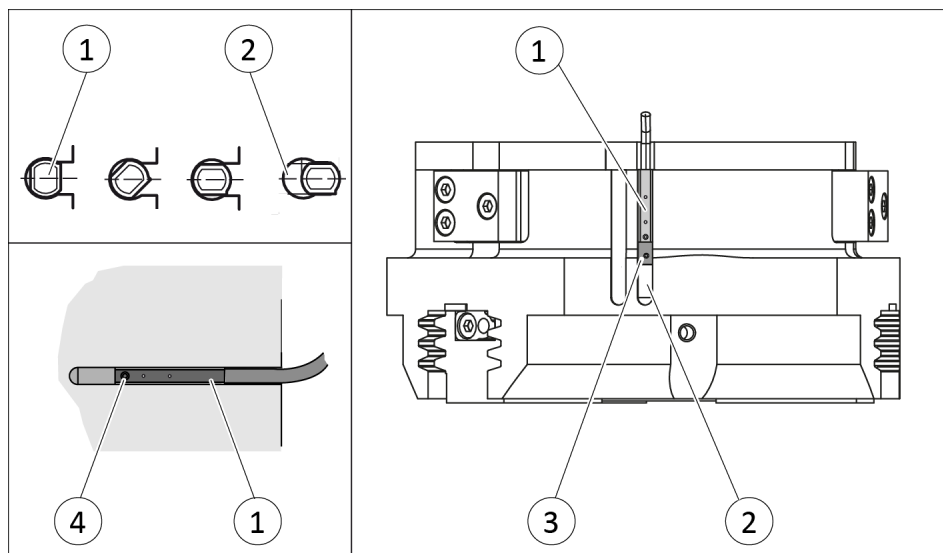

#### NOTE

If there is no T-nut available, slide the sensor according to dimension l1 into the groove (2), ► 5.3.2 [ 29].

1. Turn the sensor (1) into the groove (2).  
OR: Slide the sensor (1) into the groove (2) until the sensor (1) stops at the T-nut (3).
2. Secure the sensor (1) using the set-screw (4).  
Tightening torque: 10 Ncm
3. Adjust sensor (1), see sensor assembly and operating manual.

### 5.3.8 Mounting programmable magnetic switch MMS-P 22

#### NOTICE

#### Risk of damage to the sensor during assembly!

- Observe the maximal tightening torque.

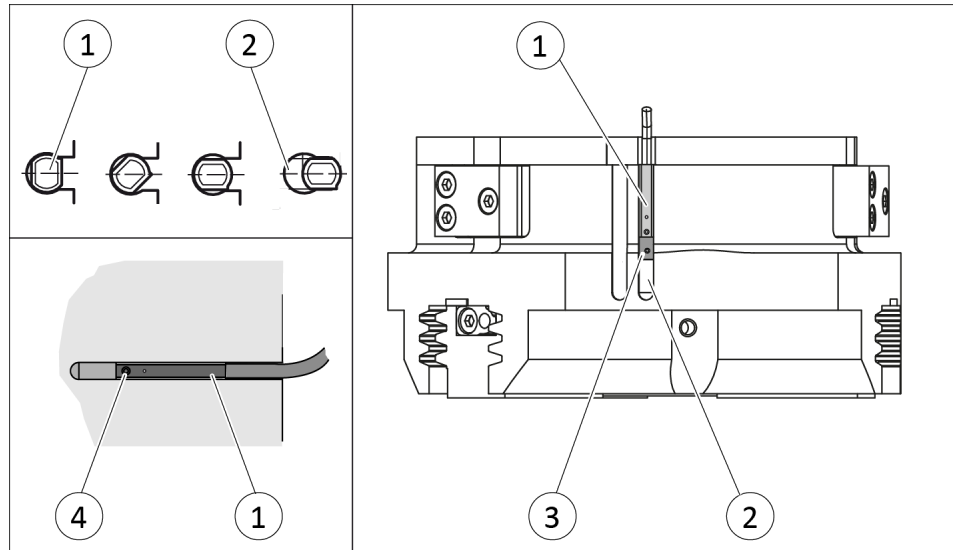

#### NOTE

If there is no T-nut available, slide the sensor according to dimension l1 into the groove (2), ► 5.3.2 [ 29].

1. Turn the sensor (1) into the groove (2).  
OR: Slide the sensor (1) into the groove (2) until the sensor (1) stops at the T-nut (3).
2. Secure the sensor (1) using the set-screw (4).  
Tightening torque: 10 Ncm
3. Adjust sensor (1), see sensor assembly and operating manual.

### 5.3.9 Mounting programmable magnetic switch MMS 22-PI1

#### NOTICE

#### Risk of damage to the sensor during assembly!

- Observe the maximal tightening torque.

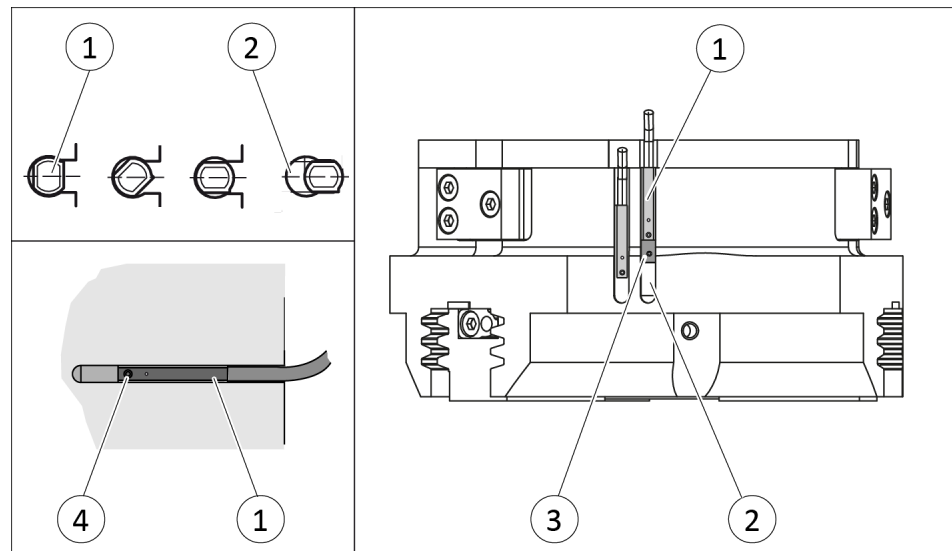

#### NOTE

The magnetic switch MMS 22-PI1 can be adjusted and taught in two ways.

- "Standard mode" allows for quick installation on the T-nut preset by SCHUNK in the groove or the defined setting dimension "l1."
- In "Optimal Mode", the sensor identifies the optimal position in the groove itself.  
SCHUNK recommends "Optimal Mode" for setting the sensors.

#### Setting the sensor in "Optimum mode"

1. Put product in the position in which it is to be set.
2. Hold teaching tool to the sensor 1 (1) until the sensor flashes.
3. Slide sensor 1 (1) into the groove (2), until the sensor 1 flashes rapidly.  
⇒ The optimum position is displayed.
4. Secure the sensor 1 (1) using the set-screw (3).  
Tightening torque: 10 Ncm
5. Hold teaching tool to the sensor 1 (1) to confirm the position.  
⇒ The sensor 1 (1) has been taught in.
6. Repeat steps for sensor 2.

## Alternativ

for sizes 40 – 160:

### Setting the sensor in "Standard mode"

1. Turn the sensor 1 (1) into the groove (2).  
OR: Slide the sensor 1 (1) into the groove (2) until the sensor 1 (1) stops at the T-nut (3).
2. Secure the sensor 1 (1) using the set-screw (4).  
Tightening torque: 10 Ncm
3. Adjust sensor 1 (1), see sensor assembly and operating manual.
4. Repeat steps for sensor 2.

---

### NOTE

If there is no T-nut available, slide the sensor according to dimension l1 into the groove (2), ► 5.3.2 [📄 29].

---

### 5.3.10 Mounting the magnetic switch MMS 22-IOL

#### NOTICE

#### Risk of damage to the sensor during assembly!

- Observe the maximal tightening torque.

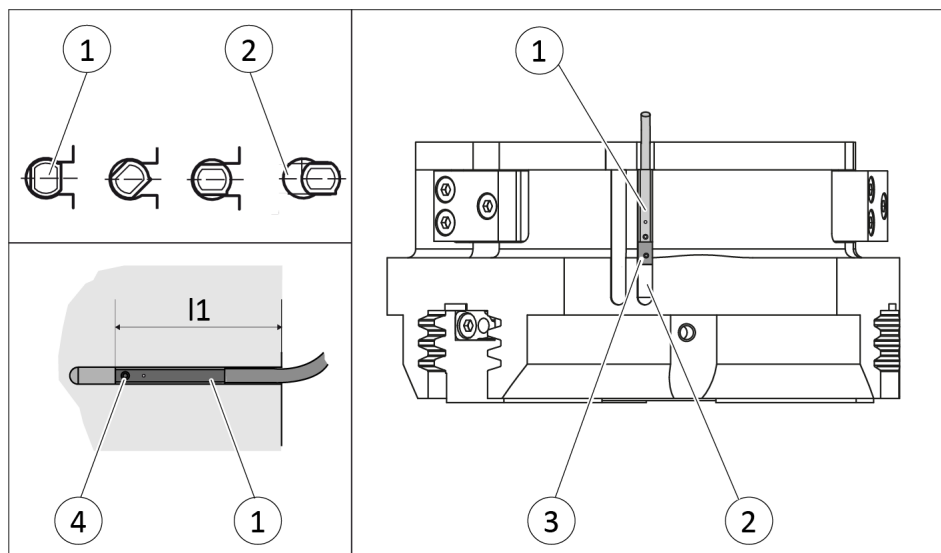

#### NOTE

If there is no T-nut available, slide the sensor according to dimension  $l_1$  into the groove (2), see following table.

Size	$l_1^*$ [mm]
64-1	24.5
64-1-AS / 64-1-IS	38.0
64-1-KVZ	45.5
64-1-AS-KVZ / 64-1-IS-KVZ	59.0
80-1	29.8
80-1-AS / 80-1-IS	29.8
80-1-KVZ	54.8
80-1-AS-KVZ / 80-1-IS-KVZ	70.8
100-1	29.8
100-1-AS / 100-1-IS	49.9
100-1-KVZ	59.8
100-1-AS-KVZ / 100-1-IS-KVZ	79.9
125-1	35.0
125-1-AS / 125-1-IS	58.5
125-1-KVZ	70.0
125-1-AS-KVZ / 125-1-IS-KVZ	93.5

Size	l1* [mm]
160-1	40.5
160-1-AS	71.75
160-1-IS	71.0
160-1-KVZ	80.5
160-1-AS-KVZ	111.75
160-1-IS-KVZ	111.0

Tab.: Setting dimensions

\* Setting dimension l1, from product bottom edge to front sensor

**Sizes 64, 80, 100, 125, 160**

1. Turn the sensor (1) into the groove (2).  
OR: Slide the sensor (1) into the groove (2) until the sensor (1) stops at the T-nut (3).
2. Secure the sensor (1) using the set-screw (4).  
Tightening torque: 10 Ncm
3. Adjust sensor (1), see sensor assembly and operating manual.
1. Turn the sensor (1) into the groove (2).  
OR: Slide the sensor (1) into the groove (2) until the sensor (1) stops at the T-nut (3).
2. Secure the sensor (1) using the set-screw (4).  
Tightening torque: 10 Ncm
3. Adjust sensor (1), see sensor assembly and operating manual.

**Size 80-AS**

During the monitoring process, the first and last 15% of the nominal stroke will not produce a change in the analog signal. It is therefore not possible to monitor the end positions. If you have questions, please contact SCHUNK.

Size	Stroke 1		Stroke 2	
	100 %	15 %	100 %	15 %
PZN-plus	8 mm	1.2 mm	4 mm	0.6 mm
80-AS				

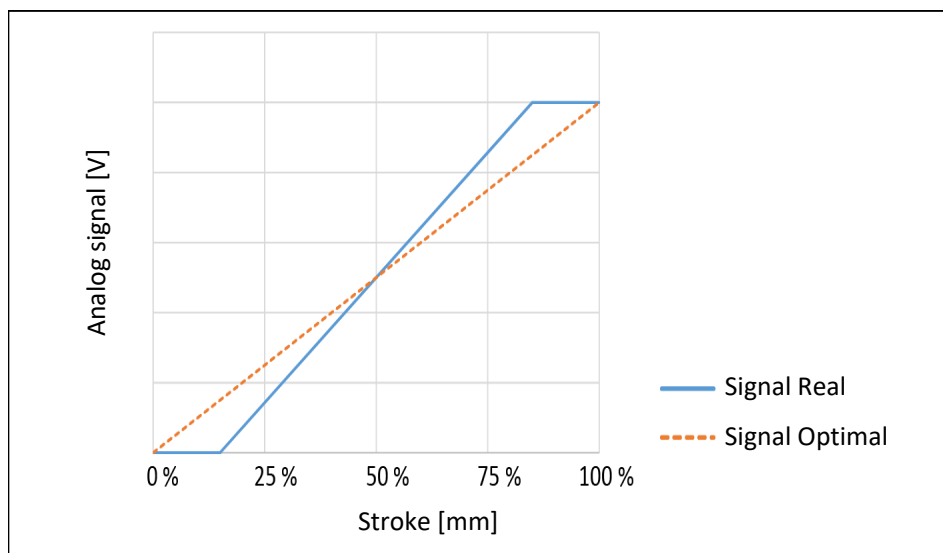

1. Turn the sensor (1) into the groove (2).  
OR: Slide the sensor (1) into the groove (2) until the sensor (1) stops at the T-nut (3).
2. Secure the sensor (1) using the set-screw (4).  
Tightening torque: 10 Ncm

---

#### NOTE

It is not possible to use the MT magnetic teach pendant to teach the MMS-IOL for sizes 64, 100 and 160.

---

### 5.3.11 Mounting the analog position sensor APS-Z80

To be able to mount the sensor, the gripper has to be retrofitted with a special mounting kit.

#### NOTICE

#### Blockade of the gripper after setting or replacing of the switching cam!

The switching cam can be tilt in the guide, if it was not fixed exactly in the base jaw.

- Apply the switching cam in the direction of the base jaw, so that the cam does not contact the housing of the gripper.

During the monitoring process, the first 8% of the nominal stroke will not produce a change in the analog signal. With O.D. gripping the "Gripper closed" position and with I.D. gripping the "Gripper opened" position cannot be queried. Should you have questions, do not hesitate to contact SCHUNK.

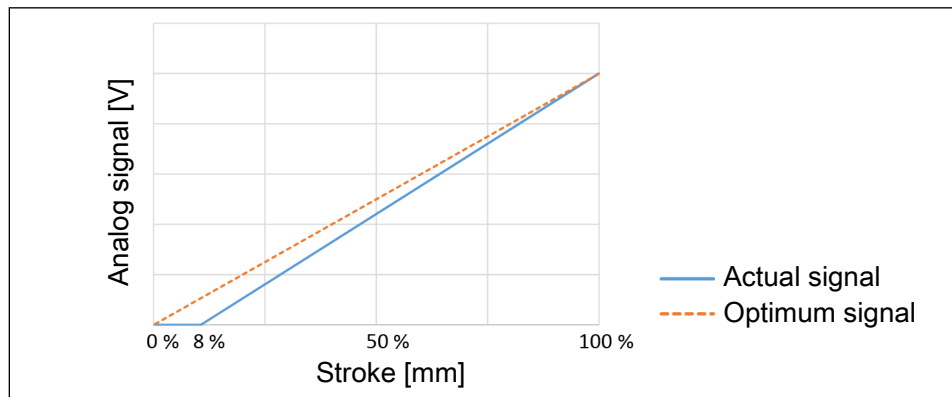

Analog signal on O.D. gripping

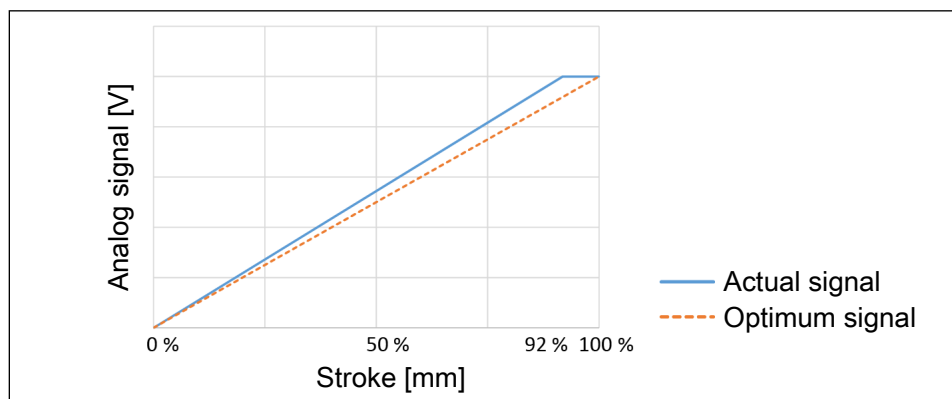

Analog signal on I.D. gripping

#### Variant Dust-tight:

Before attaching the sensor, remove the sealing bolts from the bracket. Before adjusting the control cam, unscrew the set-screw from the side cover.

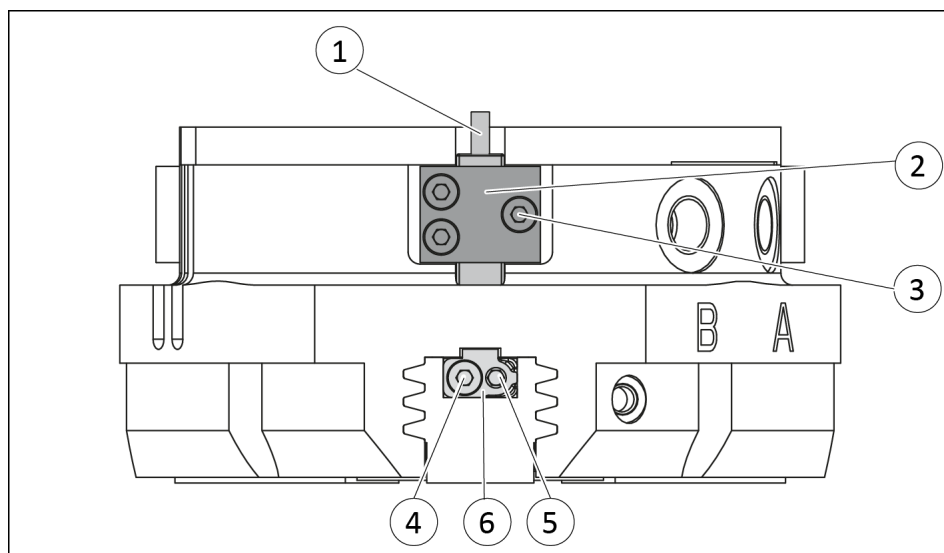

1. Move product to the "gripper open" position.
2. Loosen screw (4) and remove control cam (6) for the inductive monitoring from the base jaw.
3. Remove screw (5) from the base jaw.
4. Apply adhesive to the top and sides of the control cam (6) from the mounting kit.
  - ⇒ Make sure that there is no adhesive on the bottom of the control cam (6), which comes into contact with the sensor.
  - ⇒ SCHUNK recommends the adhesive Loctite 290 or 638.
5. Slide control cam (6) into the base jaw to the stop.
  - ⇒ Ensure that the higher front side of the control cam (6) is pointing outwards.
6. **NOTICE! The control cam (6) must no longer move after it is screwed on.**  
 Screw the control cam (6) to the base jaw using the screw (5).
  - ⇒ Secure the screw (5) with medium-strength locking liquid.
7. Slide the sensor (1) to the stop into the bracket (2).
8. Tighten the screw (3) on the bracket (2).  
 Tightening torque: 0.2 Nm
9. Adjust sensor (1), see the Sensor Assembly and Operating Manual.

**Variant Dust-tight:**

Screw in set-screw into the side cover.

### 5.3.12 Mounting reed switch RMS 22

#### NOTICE

#### Risk of damage to the sensor during assembly!

- Observe the maximal tightening torque.

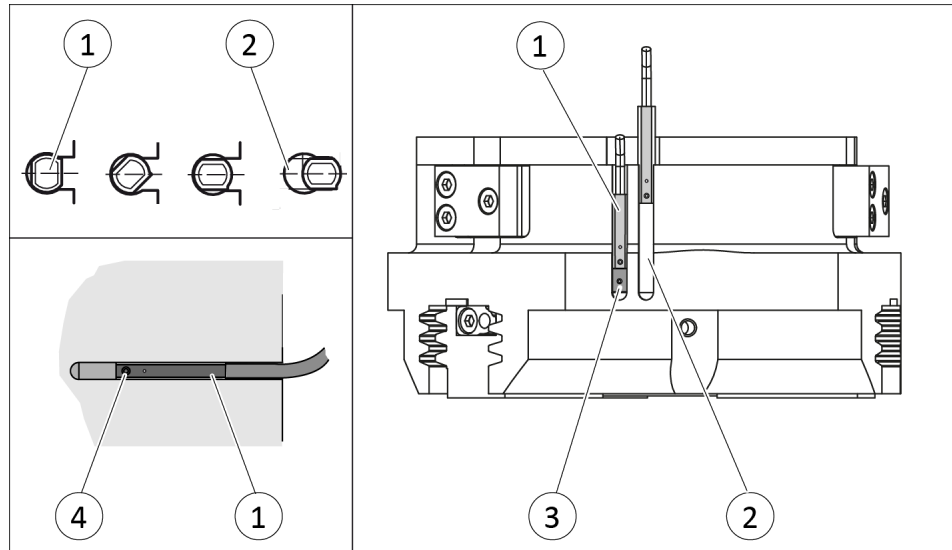

Positioning the magnetic switches

#### Position "Gripper open" or "Part gripped (I.D. gripping)"

1. Bring product in the position to be set.
2. If necessary remove T-nut (3).
3. Turn the sensor 1 (1) into the groove (2).  
OR: Slide the sensor 1 (1) into the groove (2) until the sensor 1 (1) stops at the end of the groove.
4. Pull the sensor 1 (1) back again slowly until it switches.
5. Secure the sensor 1 (1) using the set-screw (4).  
Tightening torque: 10 Ncm
6. Bring product into the "Gripper open" or "Part gripped" position and test the function.

#### Position "Gripper closed" or "Part gripped (O.D. gripping)"

1. Bring product in the position in which it is to be set.
2. If necessary remove T-nut (3).
3. Turn the sensor 2 (1) into the groove (2).  
OR: Slide sensor 2 (1) into the groove (2) in the direction of the housing middle (3), until the sensor 2 (1) switches.
4. Secure the sensor 2 (1) using the set-screw (4).  
Tightening torque: 10 Ncm
5. Bring product into the "Gripper closed" or "Part gripped" position and test the function.

### 5.3.13 Mounting the reed switch RMS 80

#### NOTICE

#### Blockade of the gripper after setting or replacing of the switching cam!

The switching cam can be tilt in the guide, if it was not fixed exactly in the base jaw.

- Apply the switching cam in the direction of the base jaw, so that the cam does not contact the housing of the gripper.

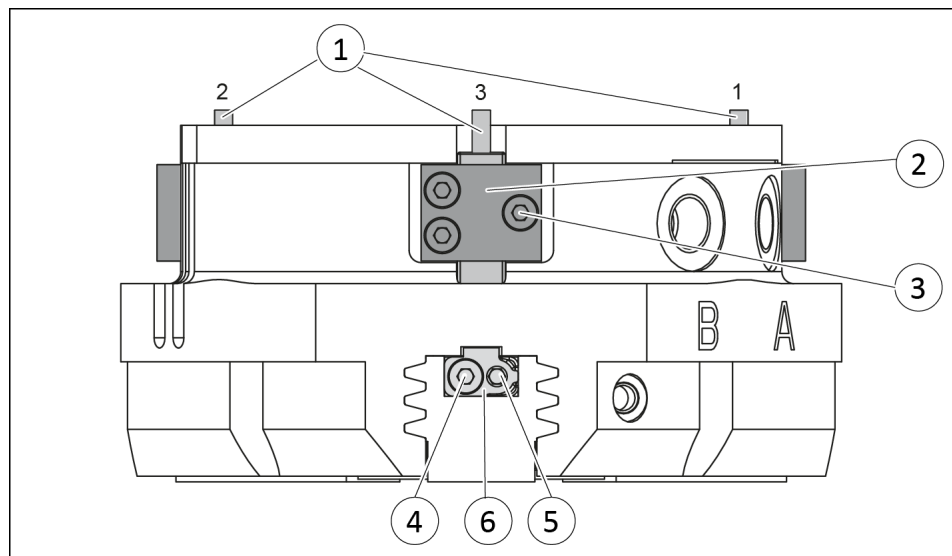

#### NOTE

The screws (4) and (5) differ in length. With size 380, these screws on sensor 3 (1) are the same length.

#### Variant Dust-tight:

Before attaching the sensor, remove the sealing bolts from the bracket. Before adjusting the control cam, unscrew the set-screw from the side cover.

#### Position "Gripper open" or "Part gripped (I.D. gripping)"

1. Slide the sensor 1 (1) or sensor 2 (1) to the stop into the bracket (2).
2. Tighten the screw (3) on the bracket (2).  
Tightening torque: 0.2 Nm
3. Open gripper or grip part.
4. Undo the screw (4).
5. Turn the screw (5) to push the position of the control cam (6).

- ⇒ Slide control cam (6) inwards until the sensor 1 (1) no longer responds.  
Move the control cam (6) back towards the outside until the sensor 1 (1) begins to switch.
- 6. Tighten screw (4) and in doing so press the control cam in the direction of the gripper fingers. **NOTICE! The control cam may tilt in the guide if it has not been tightened properly.**
  - ⇒ Switching point is set.
- 7. Bring product into the "Gripper open" or "Part gripped" position and test the function.

### NOTE

If the switching position cannot be queried, it may be that the alignment of the control cam has to be changed, ▶ 5.3.4 [ 31].

### Position "Gripper closed" or "Part gripped (O.D. gripping)"

1. Slide the sensor 3 (1) to the stop into the bracket (2).
2. Tighten the screw (3) on the bracket (2).  
Tightening torque: 0.2 Nm
3. Close gripper or grip part.
4. Undo the screw (4).
5. Turn the screw (5) to push the position of the control cam (6).
  - ⇒ Slide control cam (6) outwards until the sensor 3 (1) no longer responds.  
Move the control cam (6) back towards the inside until the sensor 3 (1) begins to switch.
6. Tighten screw (4) and in doing so press the control cam in the direction of the gripper fingers. **NOTICE! The control cam may tilt in the guide if it has not been tightened properly.**
  - ⇒ Switching point is set.
7. Bring product into the "Gripper closed" or "Part gripped" position and test the function.

### NOTE

If the switching position cannot be queried, it may be that the alignment of the control cam has to be changed, ▶ 5.3.4 [ 31].

### Variant Dust-tight:

Screw in set-screw into the side cover.

### 5.3.14 Mounting flexible position sensor FPS

The flexible position sensor FPS consists of an evaluation unit and the sensor FPS-S-M8.

#### NOTICE

#### Risk of damage to the sensor during assembly!

- Observe the maximal tightening torque.

To be able to mount the sensor, the gripper has to be retrofitted with a special mounting kit.

#### Variant Dust-tight:

Before attaching the sensor, remove the sealing bolts from the bracket. Before adjusting the control cam, unscrew the set-screw from the side cover.

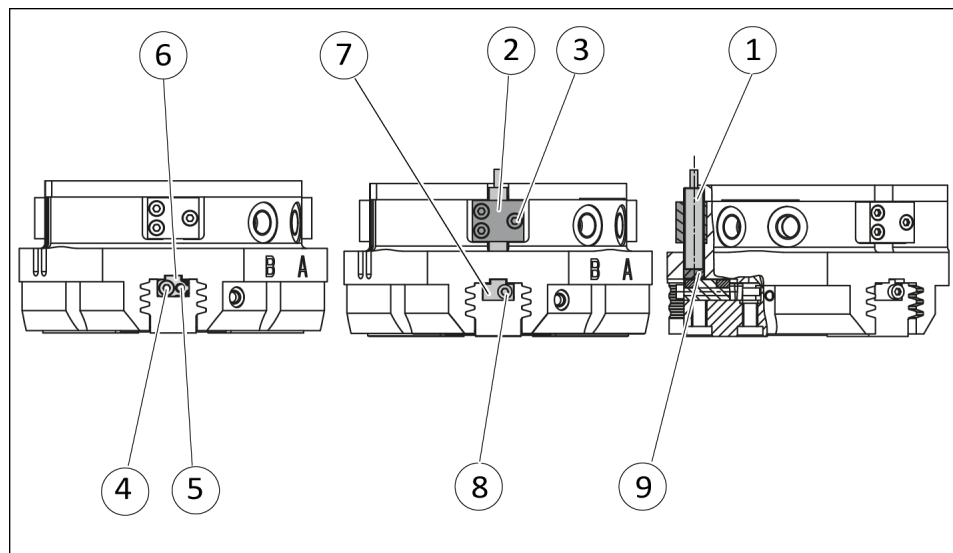

1. Move product to the "gripper open" position.
2. Loosen screw (4) and remove control cam (6) for the inductive monitoring from the base jaw.
3. Remove screw (5) from the base jaw.
4. Slide control cam (7) from the mounting kit with the recess at the front into the base jaw.
5. Screw the control cam (7) to the base jaw using the screw (8).
6. Slide spacer shim (9) into the bracket (2) to the stop.
7. Slide the sensor (1) to the stop into the bracket (2).
8. Tighten the screw (3) on the bracket (2).  
Tightening torque: 0.2 Nm
9. Adjust sensor (1), see assembly and operating manual of the sensor.

#### Variant Dust-tight:

Screw in set-screw into the side cover.

### 5.3.15 Mounting the analog position sensor APS-M1

To be able to mount the sensor, the gripper has to be retrofitted with a special mounting kit.

#### NOTICE

#### Blockade of the gripper after setting or replacing of the switching cam!

The switching cam can be tilt in the guide, if it was not fixed exactly in the base jaw.

- Apply the switching cam in the direction of the base jaw, so that the cam does not contact the housing of the gripper.

#### Variant Dust-tight:

Before attaching the sensor, remove the sealing bolts from the bracket. Before adjusting the control cam, unscrew the set-screw from the side cover.

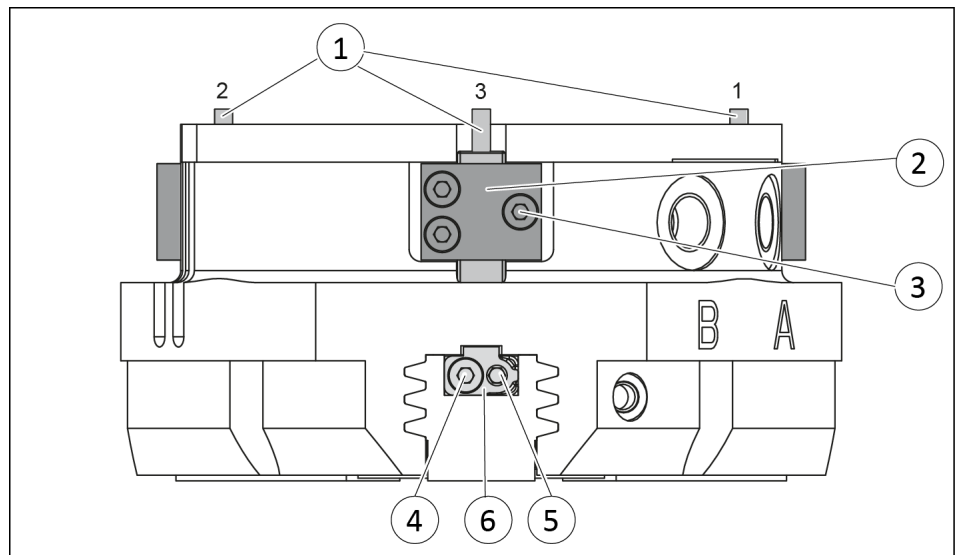

1. Move product to the "gripper open" position.
2. Loosen screw (4) and remove control cam (6) for the inductive monitoring from the base jaw.
3. Apply adhesive to the top and sides of the control cam (6) from the mounting kit.
  - ⇒ Make sure that there is no adhesive on the bottom of the control cam (6), which comes into contact with the sensor.
  - ⇒ SCHUNK recommends the adhesive Loctite 290 or 638.
4. Slide control cam (6) out of the mounting kit front into the base jaw.
  - ⇒ Ensure that the higher front side of the control cam (6) is pointing outwards.

5. Tighten screw (4) slightly.
6. Turn the screw (5) to push the position of the control cam (6).
7. Tighten screw (4) and in doing so press the control cam (6) in the direction of the gripper finger.
8. Slide the sensor (1) to the stop into the bracket (2).
9. Tighten the screw (3) on the bracket (2).  
Tightening torque: 0.2 Nm
10. Adjust sensor (1), see assembly and operating manual of the sensor.

**Variant Dust-tight:**

Screw in set-screw into the side cover.

### 5.3.16 Mounting the radio system RSS-R1/T2

The radio system RSS-R1/T2 can be used with the following sensors:

- Reed switch RMS 80

1. Install the sensor, ▶ 5.3.13 [ 45].
2. Adjust the sensor, see the assembly and operating manual for the sensor.
3. Connect the radio system, see the assembly and operating manual for the radio system.

## Assembly

## 6 Troubleshooting

### 6.1 Product is not moving

Possible cause	Corrective action
Base jaws jam in housing, e.g. mounting surface is not sufficiently even.	Check the evenness of the mounting surface. ▶ 5.2.1 [ 23]
	Loosen the mounting screws of the product and actuate the product again.
Pressure drops below minimum.	Check air supply. ▶ 5.2.2 [ 26]
Compressed air lines switched.	Check compressed air lines. ▶ 5.2.2 [ 26]
Proximity switch defective or set incorrect.	Readjust or change sensor.
Unused air connections open.	Close unused air connections.
Flow control valve closed.	Open the flow control valve.
Component part defective.	Replace component or send it to SCHUNK for repair.

### 6.2 Product is not executing the complete stroke

Possible cause	Corrective action
Dirt deposits between cover and piston.	Clean and if necessary re-lubricate.
Dirt deposits between basic jaws and guidance.	Disassemble and clean the product.
Pressure drops below minimum.	Check air supply. ▶ 5.2.2 [ 26]
Mounting surface is not sufficiently flat.	Check the evenness of the mounting surface. ▶ 5.2.1 [ 23]
Component part defective.	Replace component or send it to SCHUNK for repair.

### 6.3 Product opens or closes abruptly

Possible cause	Corrective action
Too little grease in the mechanical guiding areas.	Clean and lubricate product. ▶ 7 [ 52]
Compressed air lines blocked.	Check compressed air lines of damage.
Mounting surface is not sufficiently flat.	Check the evenness of the mounting surface.
One-way flow control valve is missing or adjustet incorrectly.	Install and adjust one-way flow control valve.
Loading too large.	Check permissible weight and length of the gripper fingers.

## 6.4 Gripping force is dropping

Possible cause	Corrective action
Compressed air can escape.	Check seals, if necessary, disassemble the product and replace seals.
Too much grease in the mechanical movement space.	Clean and lubricate product.
Pressure drops below minimum.	Check air supply. ▶ 3 [D 19]
Component part defective.	Replace component or send it to SCHUNK for repair.

## 6.5 Product does not achieve the opening and closing times

Possible cause	Corrective action
Compressed air lines are not installed optimally.	If present: Open the flow control couplings on the product to the maximum that the movement of the jaws occurs without bouncing and hitting.
	Check compressed air lines.
	Inner diameters of compressed air lines are of sufficient size in relation to compressed air consumption.
	Keep compressed air lines between the product and directional control valve as short as possible.
	Flow rate of valve is sufficiently large relative to the compressed air consumption.
	<b>NOTICE! The throttle check valve must not be removed, even if the product has not reached the opening and closing times.</b>
	If you still cannot achieve the open and close times in the latest catalog, we recommend the use of quick-air-vent-valves directly at the product.
Loading too large.	Check permissible weight and length of the gripper fingers.

## 6.6 Programmable magnetic switches not switching as desired

Possible cause	Corrective action
Incorrect position of sensor	Check adjustment dimensions, ▶ 5.3.2 [D 29].
Magnetic field too weak	Check function of sensor in both grooves.

## 7 Maintenance

### 7.1 Notes



#### **⚠ DANGER**

##### **Danger of explosion in potentially explosive areas!**

- Observe supplementary sheet for products with explosion-resistant versions "PZN-plus -...-EX".



#### **⚠ WARNING**

##### **Risk of burns through contact with hot surfaces!**

Surfaces of components can heat up severely during operation. Skin contact with hot surfaces causes severe burns to the skin.

- For all work in the vicinity of hot surfaces, wear safety gloves.
- Before carrying out any work, make sure that all surfaces have cooled down to the ambient temperature.

#### **Original spare parts**

Use only original spare parts of SCHUNK when replacing spare and wear parts.

#### **Replacement of the housing and base jaws**

The base jaws and the guides in the housing are matched to each other. To replace these parts, send the product to SCHUNK with a repair order.

#### **Maintenance of version with gripping force maintenance I.D. gripping and O.D. gripping**

The pistons have to be aligned using an assembly device. Therefore we recommend to have the module serviced and the seals replaced by SCHUNK.

## 7.2 Maintenance intervals

### NOTICE

#### Material damage due to hardening lubricants!

Lubricants harden more quickly at temperatures above 60°C, leading to possible product damage.

- Reduce the lubricant intervals accordingly.

---

Interval (million	10 (Size 40 – 160)
cycles):	5 (Size 200 – 300)
	0.05 (Size 380)

---

- |                  |   |
|------------------|---|
| Maintenance work | <ul style="list-style-type: none"> <li>• Clean all parts thoroughly, check for damage and wear, if necessary replace seals and wearing parts, ▶ 7.4 [ 55].<br/>The seals are in the enclosed sealing kit., ▶ 1.4.1 [ 9].</li> <li>• Treat all grease areas with lubricant, ▶ 7.3 [ 54].</li> <li>• Oil or grease external steel parts.</li> </ul> |
|------------------|---|
-

### 7.3 Lubricants/greasing areas (basic lubrication)

During maintenance, treat all greased areas with lubricant. Thinly apply lubricant with a lint-free cloth.

SCHUNK recommends the lubricants listed.

Lubricant point	Lubricant
Metallic sliding surfaces	SCHUNK grease 3
Seals and sealing surfaces	SCHUNK grease 1
Bore hole at the piston	SCHUNK grease 1

Details regarding SCHUNK lubricant designations are available at [schunk.com/lubricants](http://schunk.com/lubricants).

The product contains food-compliant lubricants as standard.

**The requirements of standard EN 1672-2:2020 are not fully met.**

#### NOTE

- Change contaminated food-compliant lubricant.
- Observe information in the safety data sheet from the lubricant manufacturer.

#### PZN-plus 40 - 300

Depending on the load, the guides in the housing can be re-lubricated.

#### PZN-plus 380

The lubrication is made via the lubricating nipples on the lubricating hole. The other lubricating holes must be closed with a grub screw. Therefore 15 ml of the lubricant have to be pumped in the gripper using the lubricating nipples. After the lubricating process, remove the lubricating nipples and close the lubricating hole with a grub screw.

All other lubrication points like seal and hole at the piston must be relubricated every 1 million cycles. Therefore the gripper must be disassembled.

## 7.4 Disassembly and assembly

### 7.4.1 Variant with dust cover

Position of the item numbers ▶ 7.5.2 [ 66 ]

The dust cover has to be removed in advance for versions with a dust cover.

1. Unscrew and remove the screws (92) and remove the washers (93) and the centering sleeves (86). Items 92 and 93 are only used for securing devices for transportation.
2. Pull out the intermediate jaws (84) upwards and remove the O-rings (87) and the intermediate plates (83).
3. Undo the countersunk screws (89) and remove the cover plate (82).
4. Unscrew the screws (90) and remove the covers (81).

### 7.4.2 Version without gripping force maintenance

Position of the item numbers ▶ 7.5 [ 64 ]



#### **⚠ WARNING**

##### **Risk of injury due to unexpected movements!**

If the power supply is switched on or residual energy remains in the system, components can move unexpectedly and cause serious injuries.

- Before starting any work on the product: Switch off the power supply and secure against restarting.
- Make sure, that no residual energy remains in the system.



#### **⚠ WARNING**

##### **In the case of the version with the pressure piece, the pressure piece is spring-loaded!**

1. Remove air pressure lines.
2. Carefully undo the set-screw (74) and pull out the pressure piece.
3. Undo the screws (47) and then remove the cover plate (5).
4. Mark the installation position for the piston (3/8) and the base jaw in the housing.
5. Undo the screws (41) and then remove the cover (4).
6. Mark the installation position between the cylinder piston (60) and the housing (1). Fully undo the screw (40) and remove the cylinder piston (60) from the housing (1).
7. Push the piston (3 / 8) upwards and out of the housing (1).
8. Pull the base jaw (2 / 7) out of the housing (1).

### 7.4.3 Version with gripping force maintenance 0.D.



#### **⚠ WARNING**

##### **Danger due to very high spring forces!**

- From size 240 and higher, it is strongly recommended to have the gripper disassembled by SCHUNK for maintenance and seal replacement.



#### **⚠ WARNING**

##### **Risk of injury due to spring forces!**

During disassembly, the cover and the cylinder pistons may be ejected by the high spring forces.

- Prevent the cover from being ejected during disassembly (e.g. with the press/vise)



#### **⚠ WARNING**

##### **Risk of injury due to unexpected movements!**

If the power supply is switched on or residual energy remains in the system, components can move unexpectedly and cause serious injuries.

- Before starting any work on the product: Switch off the power supply and secure against restarting.
- Make sure, that no residual energy remains in the system.

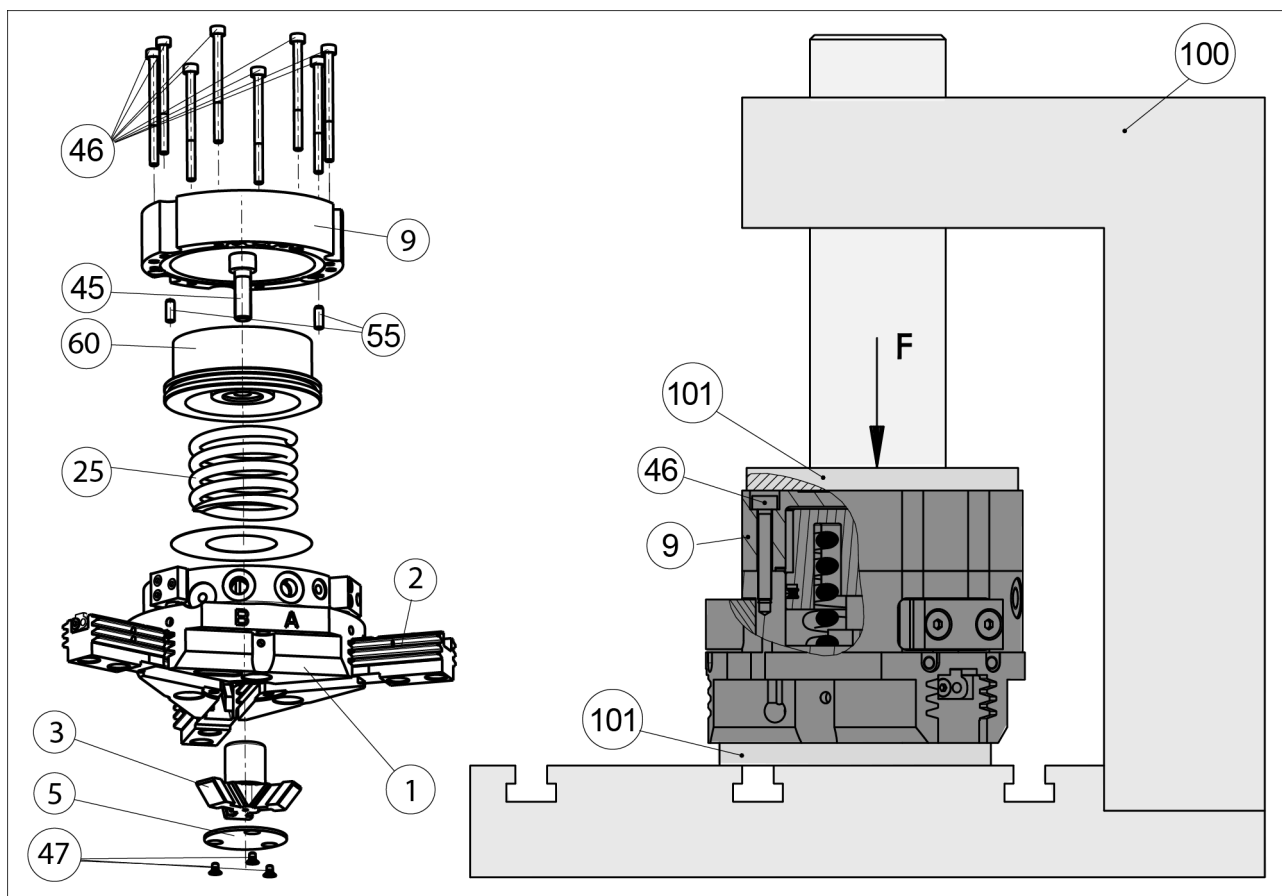

1. Remove the compressed air lines.
2. Unscrew the screws (47) and remove the cover plate (5).
3. Mark the installation position of the piston (3) and the base jaws in the housing.
4. Clamp the gripper with suitable plastic support (101) between the base jaws (2) and the cover (9) in the press (100) so that it is still possible to remove the 8 screws (46).
5. Unscrew the screws (46).
6. Carefully open the press (100).
7. Remove cover (5).
8. Remove the centering pins (55).

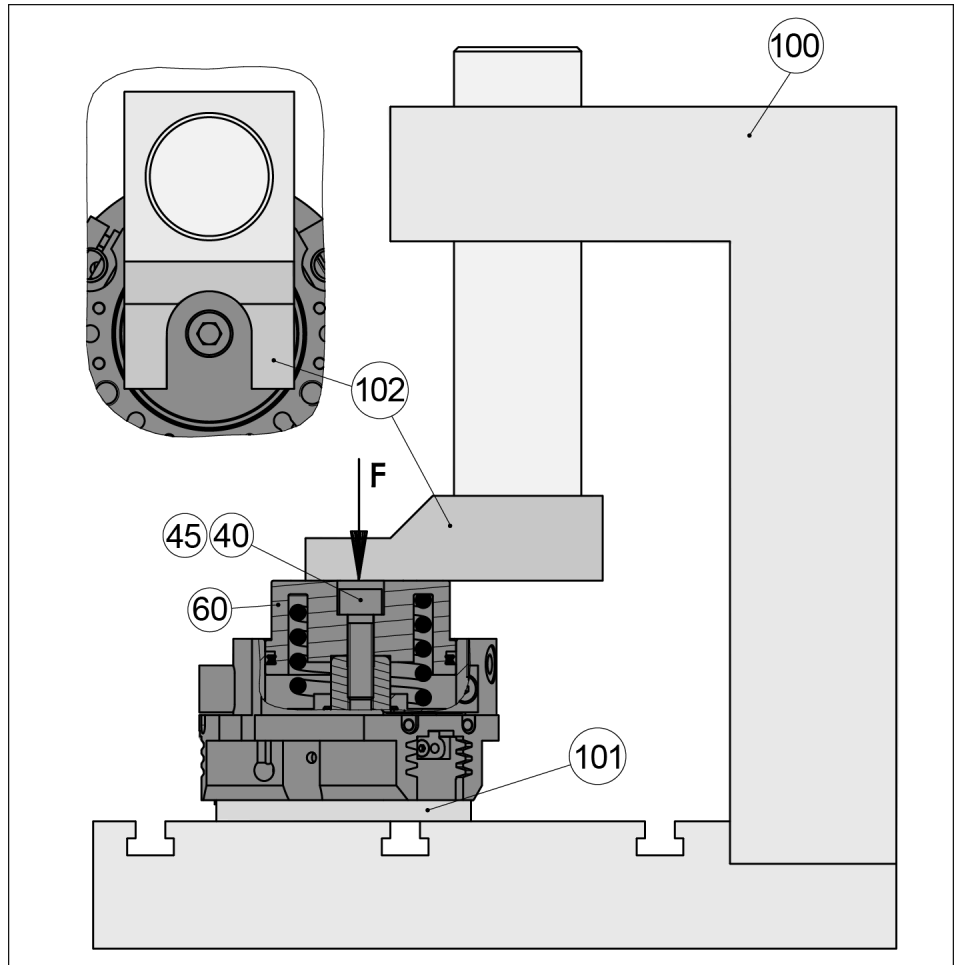

- 9.** Mark the installation position between the cylinder piston (60) and the housing (1) (note the position of the magnet).
- 10.** Clamp the gripper between the base jaws (2) and cylinder piston (60) in a press (100) with plunger (102) (assembly force F: ▶ 7.4.8 [ 63]).
- 11.** Unscrew screw (45) and carefully open the press (100) until the compression springs have no more tension.
- 12.** Remove the cylinder piston (60) and compression springs (25) from the housing (1).
- 13.** Push the piston (3) upwards out of the housing (1).
- 14.** Pull the base jaws (2) out of the housing (1).

#### 7.4.4 Version with gripping force maintenance I.D.



##### **⚠ WARNING**

##### **Danger due to very high spring forces!**

- With regard to size PZN-plus 240, 300 and 380 with gripping force maintenance, we urgently recommend that you get SCHUNK to disassemble the gripper for the purpose of maintenance and seal replacement!



##### **⚠ WARNING**

##### **Risk of injury due to spring forces**

When disassembling, the cover can be thrown out by high spring forces.

- Secure the cover from being ejected during disassembly (e.g. in a press)



##### **⚠ WARNING**

##### **Risk of injury due to unexpected movements!**

If the power supply is switched on or residual energy remains in the system, components can move unexpectedly and cause serious injuries.

- Before starting any work on the product: Switch off the power supply and secure against restarting.
- Make sure, that no residual energy remains in the system.

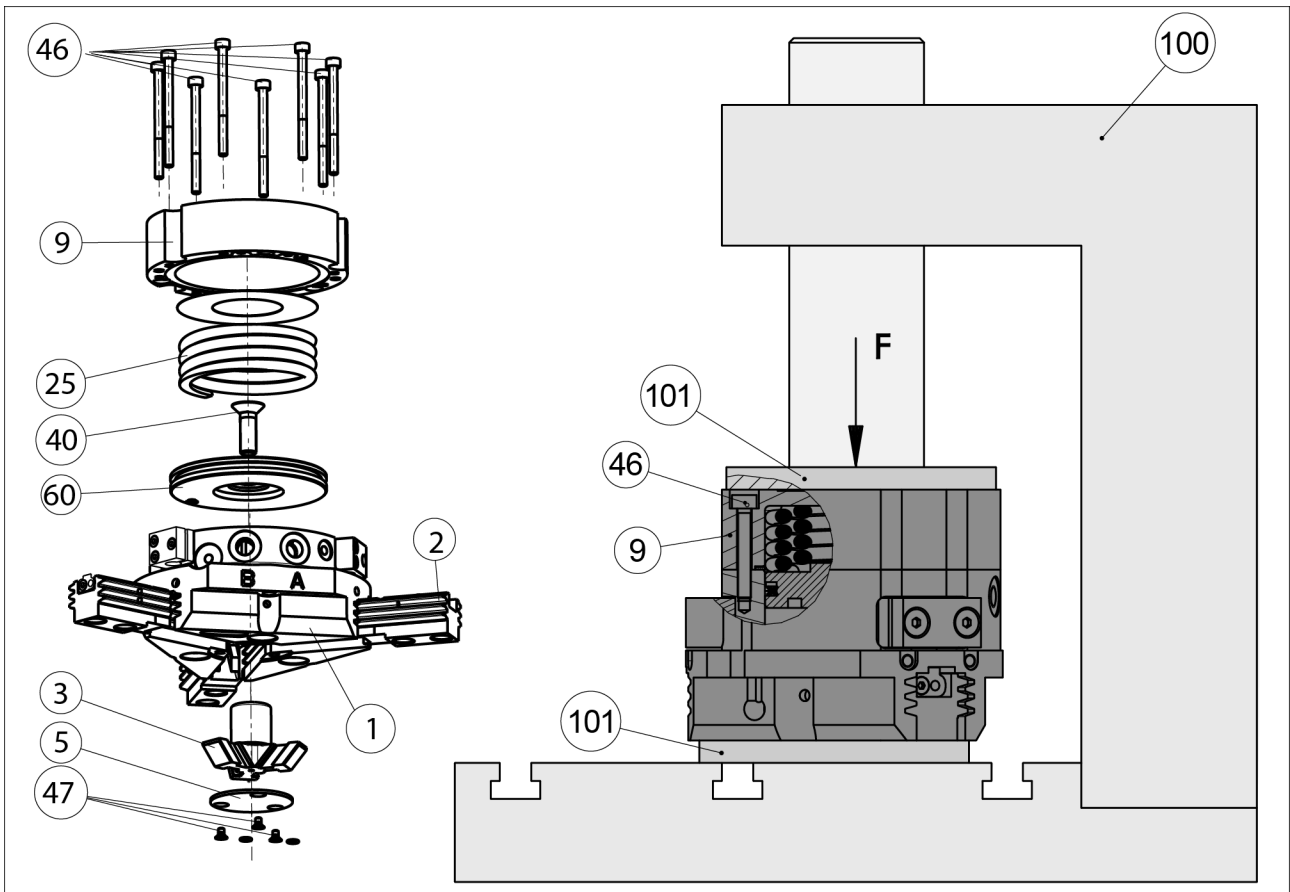

1. Remove the compressed air lines.
2. Undo the screws (47) and then remove the cover plate (5).
3. Mark the installation position for the piston (3) and the base jaw (2) in the housing (1).
4. Clamp the gripper with suitable plastic base (101) between the base jaws (2) and the cover (9) in a press (100), so that the screws (46) still can be removed.
5. Unscrew the screws (46).
6. Open press (100) carefully. until the compression spring is no longer under tension.
7. Remove cover and compression springs.
8. Mark the installation position for the piston (60) an the housing (1).
9. Undo the screws (40)
10. Remove the cylinder piston (60) out of the housing (1).
11. Push the pistons (3) upwards out of the housing (1).
12. Pull the base jaws (2) out of the housing (1).

### 7.4.5 Version with force amplification cylinder (KVZ)



#### **⚠ WARNING**

##### **Danger due to very high spring forces!**

- For sizes PZN-plus 240, 300 and 380 with gripping force maintenance, we strongly recommend having the gripper disassembled by SCHUNK for maintenance and seal replacement.



#### **⚠ WARNING**

##### **Risk of injury due to spring forces!**

During disassembly, the cover may be ejected due to the high spring forces.

- Prevent the cover from being ejected during disassembly (e.g. in the press)



#### **⚠ WARNING**

##### **Risk of injury due to unexpected movements!**

If the power supply is switched on or residual energy remains in the system, components can move unexpectedly and cause serious injuries.

- Before starting any work on the product: Switch off the power supply and secure against restarting.
- Make sure, that no residual energy remains in the system.



#### **⚠ WARNING**

##### **Risk of injury due to spring forces!**

The spring-loaded pressure piece is under spring tension and may jump out when being removed.

- Carefully unfasten the set screw and slowly remove the spring-loaded pressure piece.

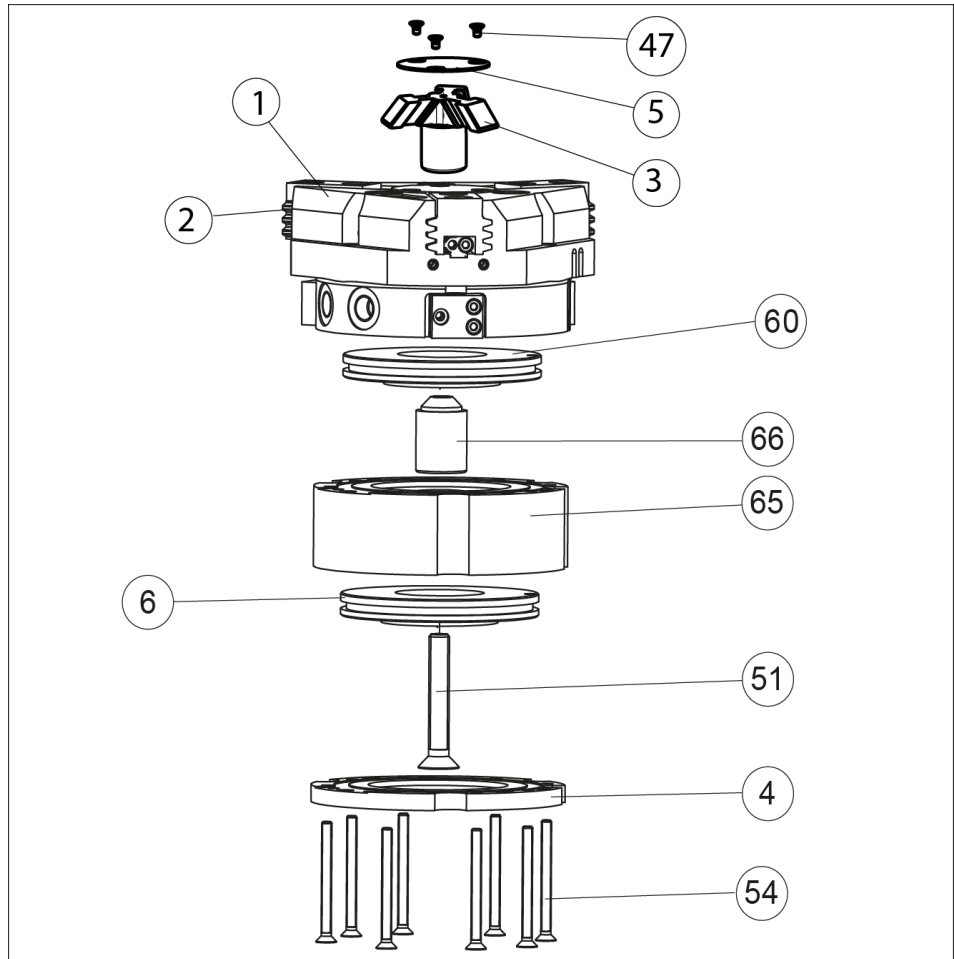

1. Remove all compressed air lines.
2. Unscrew the screws (47) and remove the cover plate (5).
3. Mark the installation position of the piston (3) and the base jaws (2) in the housing (1).
4. **Version with gripping force maintenance (AS) or (IS):** As described in the previous chapters ▶ 7.4.3 [ 56 ] / ▶ 7.4.4 [ 59 ], clamp the gripper in a press and unscrew the screws (54).
5. **Version without gripping force maintenance:** Unscrew screws (54) and remove the cover (4).
6. Unscrew the screw (51) and remove the cylinder piston (6) and the spacer piston (66) from the intermediate housing (65).
7. Remove the intermediate housing (65).
8. Mark the installation position between the second cylinder piston (60) and the housing (1). Remove the cylinder piston (60) from the housing (1).
9. Push the piston (3) upwards out of the housing (1).
10. Pull the base jaws (2) out of the housing (1).

### 7.4.6 Notes for assembly

Assembly takes place in the opposite order to disassembly.  
Observe the following:

- Unless otherwise specified, secure all screws and nuts with Loctite no. 243 and tighten with the appropriate tightening torque. ▶ 7.4.7 [ 63]
- For variant with gripping force maintenance: assemble cylinder piston using a press.
- During assembly, observe the spring forces, ▶ 7.4.8 [ 63]

### 7.4.7 Screw tightening torques

Position of the item numbers ▶ 7.5 [ 64]

Size	Item 40	Item 41	Item 45	Item 46	Item 51
40	2.2	0.45	4.9	0.45	-
50	5.9	1.2	10	1.2	-
64	12	1.2	14	1.2	12
80	12	1.3	14	1.3	12
100	20	1.3	29	2.9	20
125	49	2.9	57.5	6	49
160	96	8.5	96	10	96
200	150	20	200	25	-
240	150	20	200	25	-
300	250	35	250	50	-
380	415	58	692	50	-

Tab.: Tightening torque [Nm]

### 7.4.8 Spring force information for assembly

with gripping force  
maintenance O.D.  
gripping

Size	Pre-tension distance [mm]	Spring force [N]
40	14	174
50	6	132
64	15	261
80	27	496
100	24	875
125	29	1253
160	47	2372
200	55	4982
240	25	5016
300	90	9465
380	47	10130

**with gripping force  
maintenance I.D.  
gripping**

Size	Pre-tension distance [mm]	Spring force [N]
40	10	111
50	14	183
64	46	388
80	36	701
100	46	1389
125	71	2037
160	96	3927
200	100	7373
240	48	6267
300	100	13464
380	63	14163

## 7.5 Drawings

The following figures are example images.  
They serve for illustration and assignment of the spare parts.  
Variations are possible depending on size and variant.

### 7.5.1 Basic module

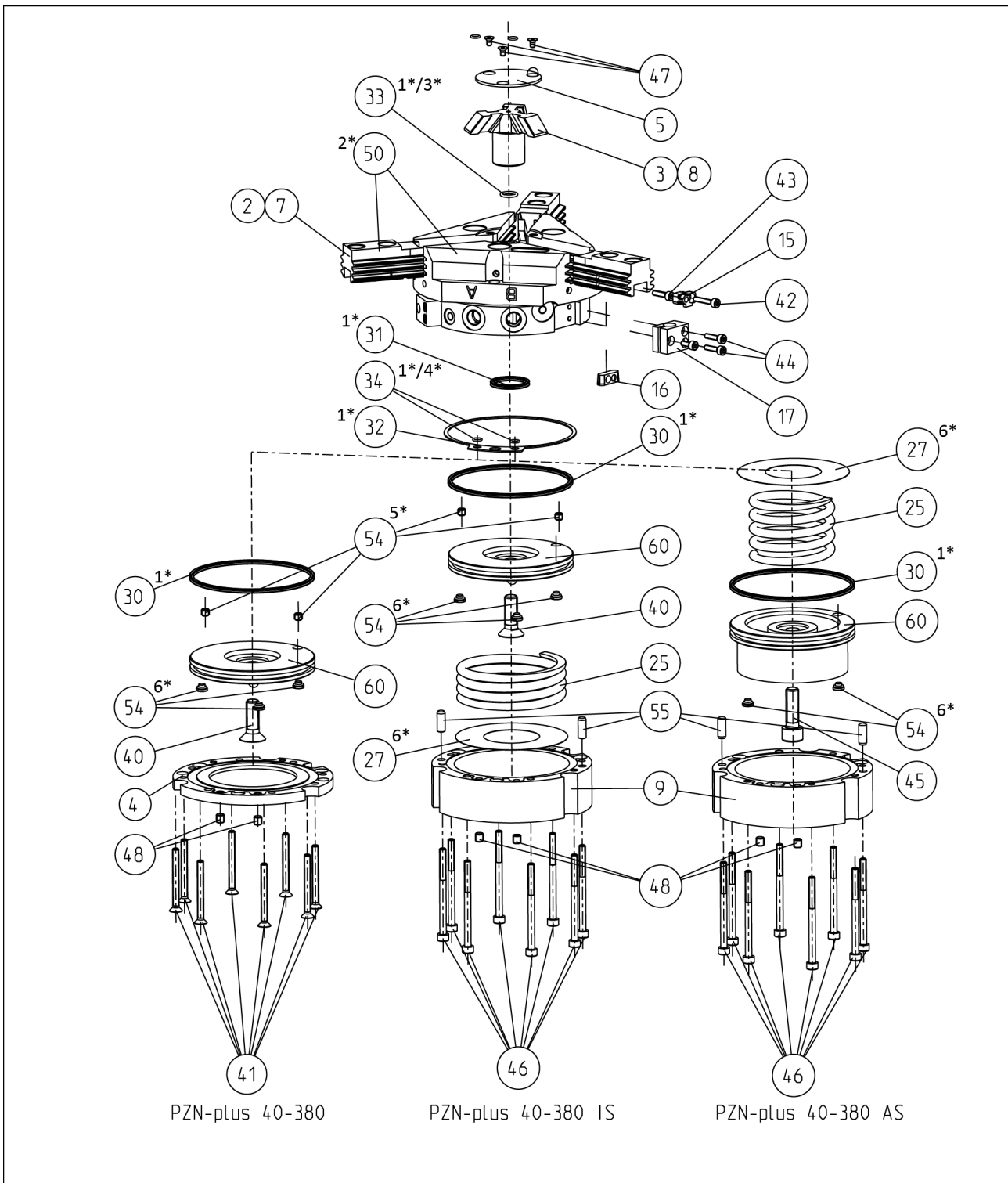

Assembly of the variants "O.D. gripping" / "I.D. gripping" / without gripping force maintenance

- 1\* Wearing part, replace during maintenance.  
Included in the seal kit. Seal kit can only be ordered completely.
- 2\* Positions are adapted to each other and can not be replaced by the customer.
- 3\* not for PZN-plus 40 – 125
- 4\* from size PZN-plus 125
- 5\* size PZN-plus 160 – 300
- 6\* at size PZN-plus 380

### 7.5.2 Variant with dust cover

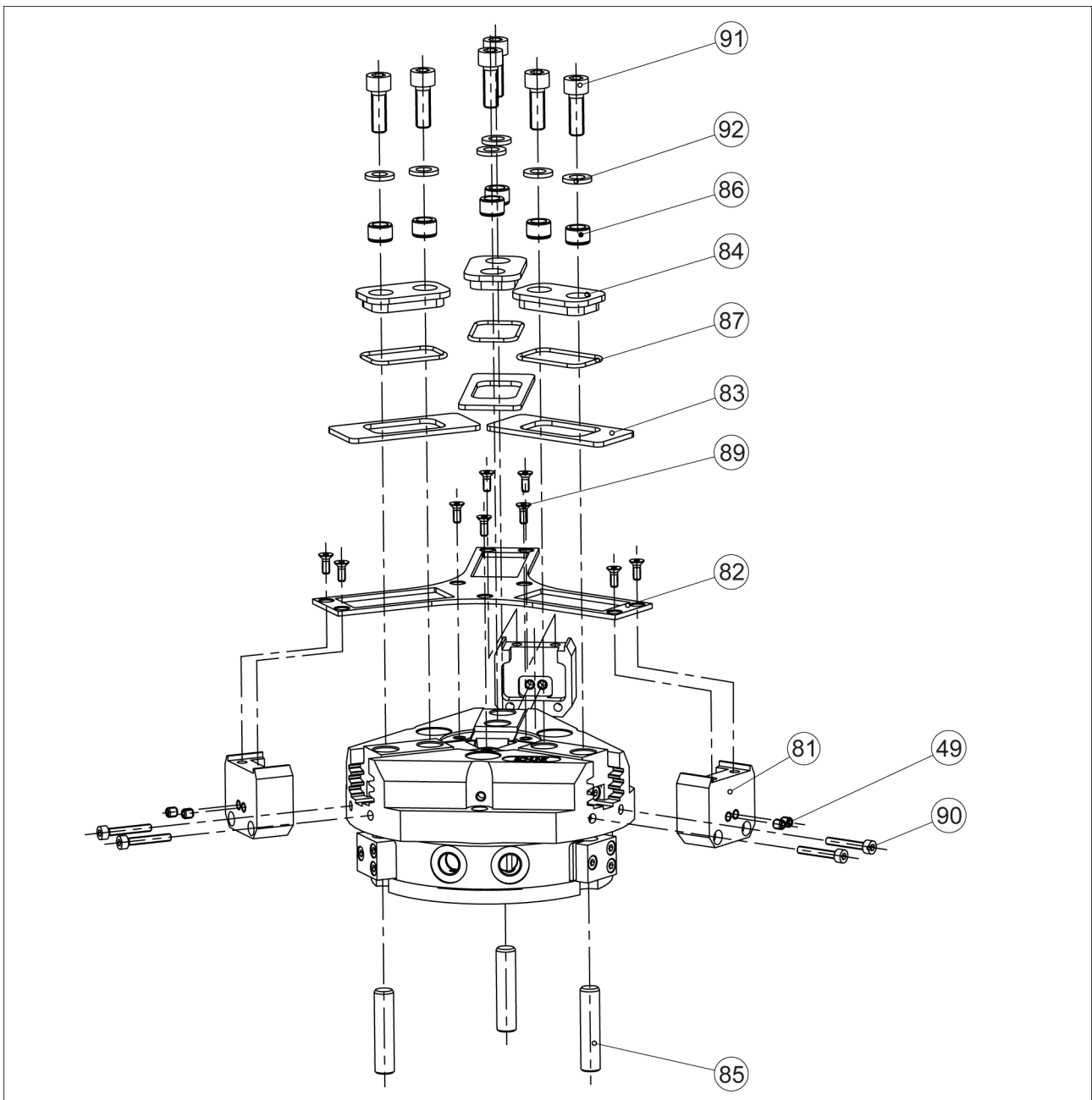

### 7.5.3 Variant with force amplification cylinder

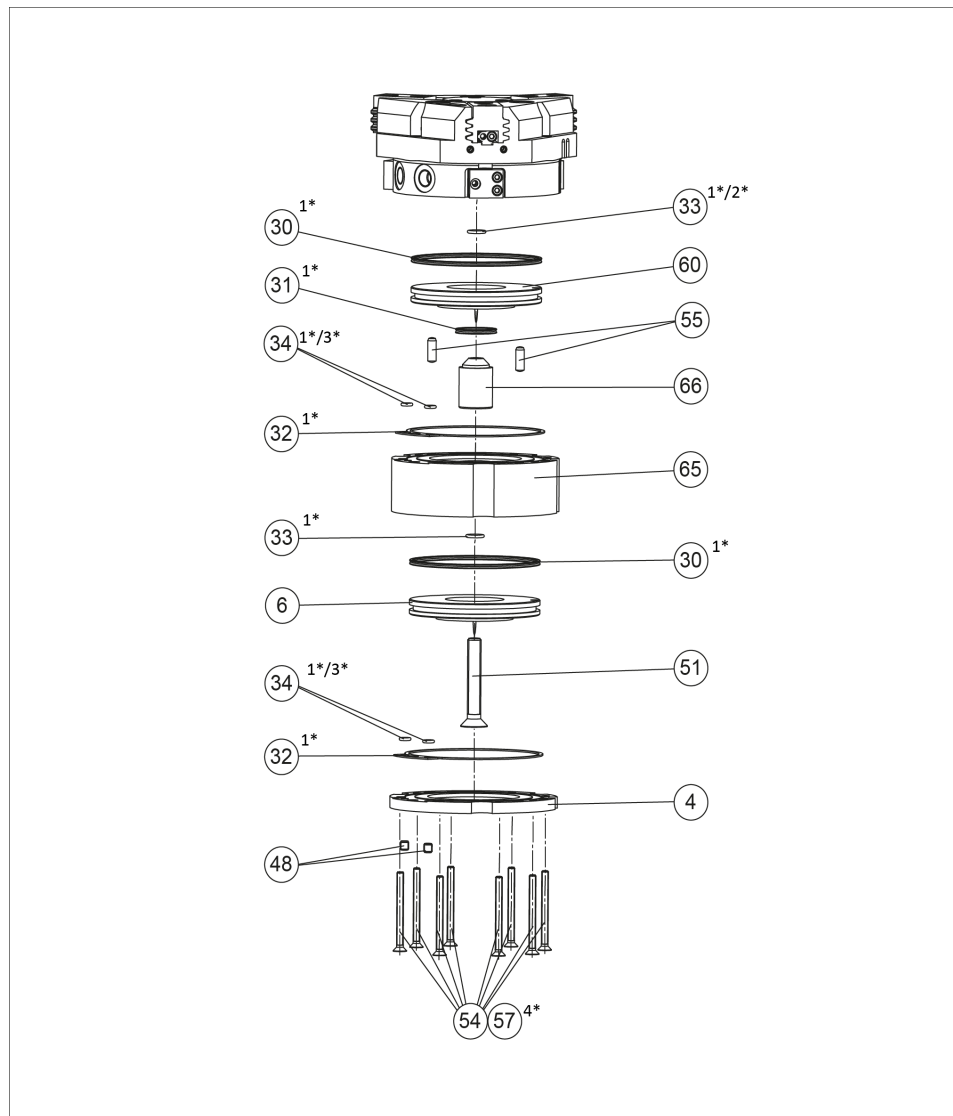

1\* Wearing part, replace during maintenance.  
Included in the seal kit. Seal kit can only be ordered completely.

---

2\* not for PZN-plus 64 - 125

---

3\* from size PZN-plus 125

---

4\* from size PZN-plus 160

---

## 8 Translation of the original declaration of incorporation

in terms of the Directive 2006/42/EG, Annex II, Part 1 Section B.

Manufacturer/  
Distributor                      SCHUNK SE & Co. KG  
Spanntechnik | Greiftechnik | Automatisierungstechnik  
Bahnhofstr. 106 – 134  
D-74348 Lauffen/Neckar

We hereby declare that the partly completed machine described below

Product designation:        3-Finger Centric Gripper / PZN-plus /pneumatic  
ID number                      0303308 ... 0303648

meets the following basic occupational health and safety of the Machinery Directive 2006/42/EC:

No. 1.1.1, No. 1.1.2, No. 1.1.3, No. 1.1.5, No. 1.3.2, No. 1.5.3, No. 1.5.4, No. 1.5.6, No. 1.5.8, No. 1.5.10, No. 1.5.11, No. 1.5.13

The partly completed machinery may not be put into operation until it has been confirmed that the machine into which the partly completed machinery is to be installed complies with the provisions of the Machinery Directive (2006/42/EC). The declaration shall be rendered invalid if modifications are made to the product.

Applied harmonized standards, especially:

EN ISO 12100:2010              Safety of machinery – General principles for design –  
Risk assessment and risk reduction

The special technical documentation according to Annex VII, Part B, belonging to the partly completed machine, has been created.

Person authorized to compile the technical documentation:  
Stefanie Walter, Address: see manufacturer's address

*Signature: see original declaration*

Lauffen/Neckar, March 2025

Dr.-Ing. Manuel Baumeister,  
Head of Systems Engineering,  
Technology & Innovation



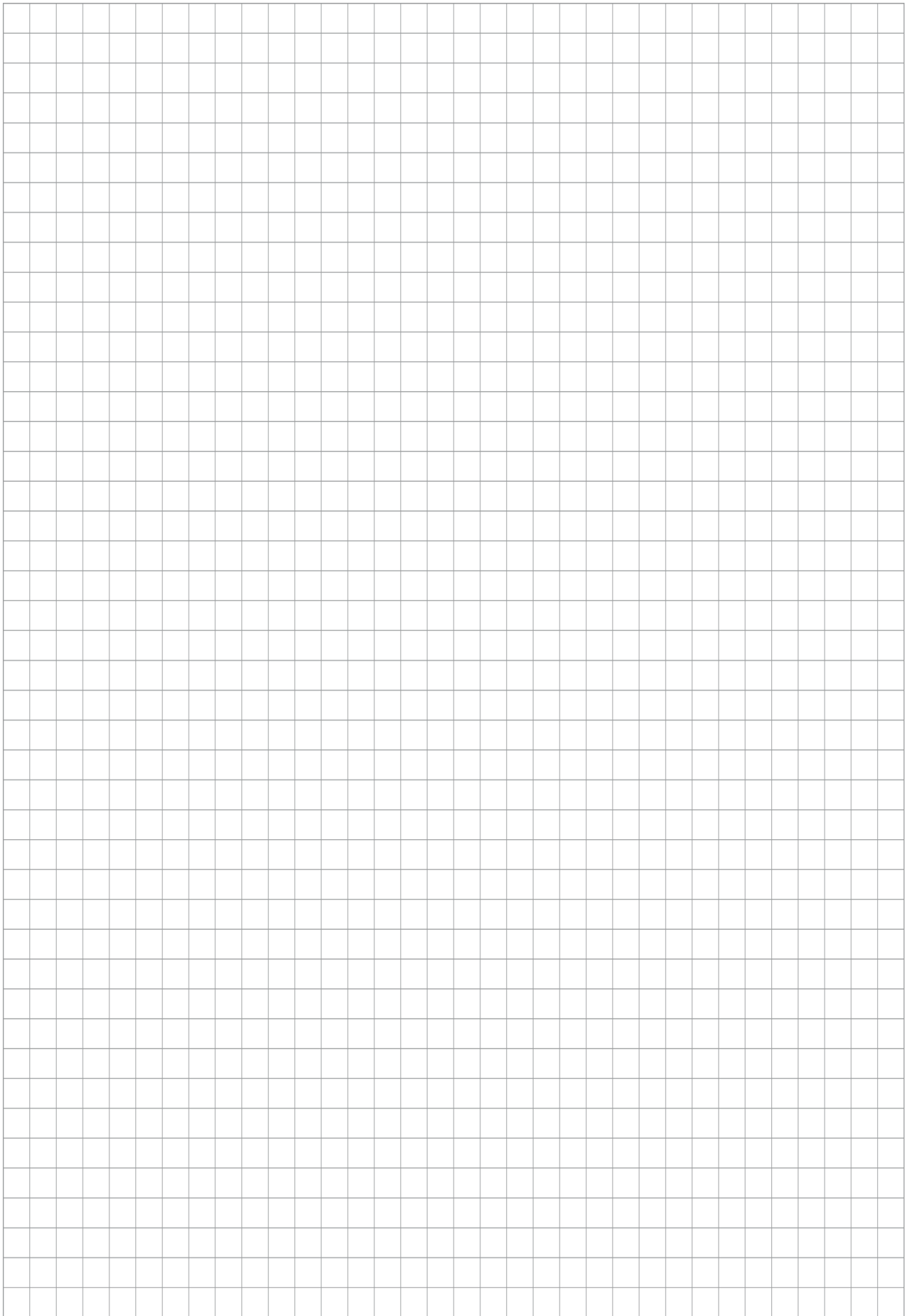

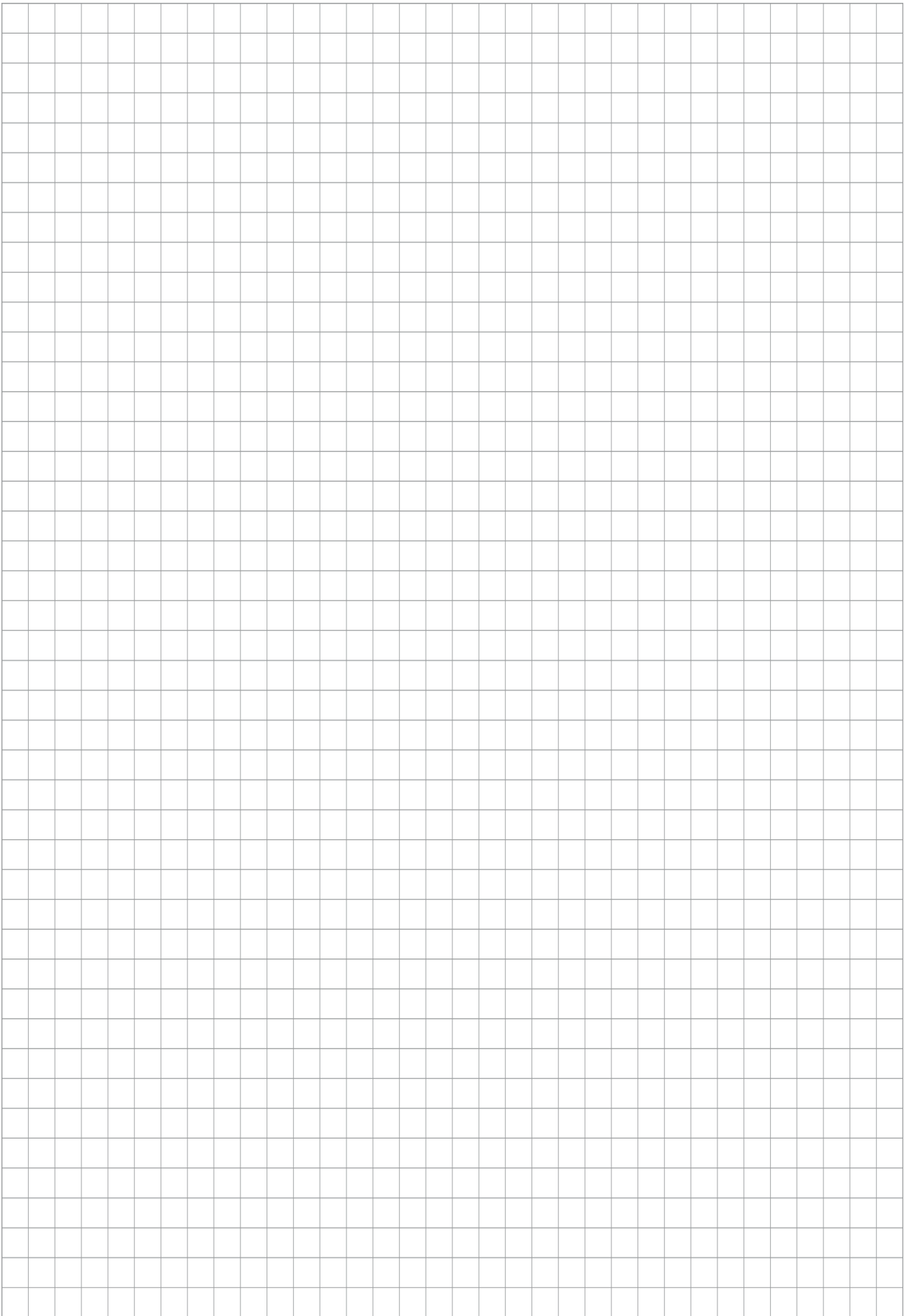



**SCHUNK SE & Co. KG**  
Spanntechnik | Greiftechnik | Automatisierungstechnik

Bahnhofstr. 106 - 134  
D-74348 Lauffen/Neckar  
Tel. +49-7133-103-0  
info@de.schunk.com  
schunk.com

Folgen Sie uns | *Follow us*



Wir drucken nachhaltig | *We print sustainable*