

Assembly and Operating Manual

SWG

2-Finger Angular Gripper

Translation of the original manual

Hand in hand for tomorrow

Imprint

Copyright:

This manual is protected by copyright. The author is SCHUNK SE & Co. KG.
All rights reserved.

Technical changes:

We reserve the right to make alterations for the purpose of technical improvement.

Document number: 389453

Version: 09.00 | 25/11/2025 | en

Dear Customer,

Thank you for trusting our products and our family-owned company, the leading technology supplier of robots and production machines.

Our team is always available to answer any questions on this product and other solutions. Ask us questions and challenge us. We will find a solution!

Best regards,

Your SCHUNK team

Customer Management

Tel. +49-7133-103-2503

Fax +49-7133-103-2189

cmg@de.schunk.com



Please read the operating manual in full and keep it close to the product.

Table of Contents

1 General	5
1.1 About this manual.....	5
1.1.1 Presentation of Warning Labels	5
1.1.2 Applicable documents	5
1.1.3 Sizes.....	6
1.2 Warranty	6
1.3 Scope of delivery.....	6
1.4 Accessories	7
2 Basic safety notes	8
2.1 Intended use.....	8
2.2 Constructional changes.....	8
2.3 Spare parts	8
2.4 Gripper fingers	8
2.5 Ambient conditions and operating conditions	9
2.6 Personnel qualification	9
2.7 Personal protective equipment	10
2.8 Notes on safe operation.....	10
2.9 Transport.....	10
2.10 Malfunctions.....	11
2.11 Disposal	11
2.12 Fundamental dangers	11
2.12.1 Protection during handling and assembly	11
2.12.2 Protection during commissioning and operation	12
2.12.3 Protection against dangerous movements	12
2.12.4 Protection against electric shock.....	13
2.13 Notes on particular risks	13
3 Technical Data	15
4 Design and description	16
4.1 Configuration	16
4.2 Description	16
5 Assembly.....	17
5.1 Assembly and connection	17
5.2 Mechanical connection.....	18
5.3 Pneumatic connection.....	19
5.4 Mounting the sensor.....	20
5.4.1 Overview of sensors	20
5.4.2 Switch-off hysteresis MMS-P.....	20

5.4.3	Setting dimensions.....	21
5.4.4	Mounting programmable magnetic switch MMS-P	21
6	Troubleshooting.....	23
6.1	Product does not move.....	23
6.2	The module does not travel through the entire stroke	23
6.3	Gripping force is dropping.....	23
6.4	The magnetic switch does not function	24
6.5	Compressed air connection is leaking	24
7	Maintenance	25
8	Translation of the original declaration of incorporation	26
9	UKCA declaration of incorporation	27

1 General

1.1 About this manual

This manual contains important information for a safe and appropriate use of the product.

This manual is an integral part of the product and must be kept accessible for the personnel at all times.

Before starting work, the personnel must have read and understood this operating manual. Prerequisite for safe working is the observance of all safety instructions in this manual.

In addition to these instructions, the documents listed under ▶ 1.1.2 [📄 5] are applicable.

NOTE: The illustrations in this manual are intended to provide a basic understanding and may deviate from the actual version.

1.1.1 Presentation of Warning Labels

To make risks clear, the following signal words and symbols are used for safety notes.



⚠ DANGER

Dangers for persons!

Non-observance will inevitably cause irreversible injury or death.



⚠ WARNING

Dangers for persons!

Non-observance can lead to irreversible injury and even death.



⚠ CAUTION

Dangers for persons!

Non-observance can cause minor injuries.

NOTICE

Material damage!

Information about avoiding material damage.

1.1.2 Applicable documents

- General terms of business *
- Catalog data sheet of the purchased product *
- Assembly and operating manuals of the accessories *

The documents labeled with an asterisk (*) can be downloaded from schunk.com/downloads.

1.1.3 Sizes

This operating manual applies to the following sizes:

- SWG10
- SWG12
- SWG16
- SWG20
- SWG25
- SWG32
- SWG40
- SWG50

1.2 Warranty

If the product is used as intended, the warranty is valid for 24 months from the ex-works delivery date under the following conditions:

- Observe the ambient conditions and operating conditions

Parts touching the workpiece and wear parts are not included in the warranty.

1.3 Scope of delivery

The scope of delivery includes

- SWG in the version ordered
- Safety information (product-specific instructions available online)
- Accessory pack

Accessory pack

Content of the accessory pack:

Size 10 – 12

- 2 x centering sleeves for mounting

Size 16 – 20

- 2 x centering sleeves for mounting
- 2 x locking screws for hose connections

Size 25 – 50

- 6 x centering sleeves for mounting
- 2 x locking screws for hose connections

Size	ID number
10	5516073
12	5515655

Size	ID number
16	5513115
20	5513116
25	5513117
32	5513118
40	5513119
50	5513120

Tab.: ID.-No. of the accessory pack

1.4 Accessories

A wide range of accessories are available for this product

For information regarding which accessory articles can be used with the corresponding product variants, see catalog data sheet.

2 Basic safety notes

2.1 Intended use

The product is designed exclusively for gripping and temporarily holding workpieces or objects.

- The product may only be used within the scope of its technical data, ▶ 3 [15].
- The product is intended for installation in a machine/ automated system. The applicable guidelines for the machine/ automated system must be observed and complied with.
- The product is intended for industrial and industry-oriented use. Its use outside enclosed spaces is only permitted if suitable protective measures are taken against outdoor exposure. The product is not suitable for use in salty air.
- The product can be used within the permissible load limits and technical data for holding workpieces during simple machining operations, but is not a clamping device according to EN 1550:1997+A1:2008.
- Appropriate use of the product includes compliance with all instructions in this manual.
- Any utilization that exceeds or differs from the appropriate use is regarded as misuse.

2.2 Constructional changes

Implementation of structural changes

Modifications, changes or reworking, e.g. additional threads, holes, or safety devices, can damage the product or impair its functionality or safety.

- Structural changes should only be made with the written approval of SCHUNK.

2.3 Spare parts

Use of unauthorized spare parts

Using unauthorized spare parts can endanger personnel and damage the product or cause it to malfunction.

- Use only original spare parts or spares authorized by SCHUNK.

2.4 Gripper fingers

Requirements for the gripper fingers

Accumulated energy can make the product unsafe and risk the danger of serious injuries and considerable material damage.

- Only change gripper fingers if no residual energy can be released.
- Make sure that the product and the top jaws are a sufficient size for the application.

2.5 Ambient conditions and operating conditions

Required ambient conditions and operating conditions

Incorrect ambient and operating conditions can make the product unsafe, leading to the risk of serious injuries, considerable material damage and/or a significant reduction to the product's life span.

- Make sure that the product is used only in the context of its defined application parameters, ▶ 3 [15].

2.6 Personnel qualification

Inadequate qualifications of the personnel

If the personnel working with the product is not sufficiently qualified, the result may be serious injuries and significant property damage.

- All work may only be performed by qualified personnel.
- Before working with the product, the personnel must have read and understood the complete assembly and operating manual.
- Observe the national safety regulations and rules and general safety instructions.

The following personal qualifications are necessary for the various activities related to the product:

Trained electrician	Due to their technical training, knowledge and experience, trained electricians are able to work on electrical systems, recognize and avoid possible dangers and know the relevant standards and regulations.
Qualified personnel	Due to its technical training, knowledge and experience, qualified personnel is able to perform the delegated tasks, recognize and avoid possible dangers and knows the relevant standards and regulations.
Instructed person	Instructed persons were instructed by the operator about the delegated tasks and possible dangers due to improper behaviour.
Service personnel of the manufacturer	Due to its technical training, knowledge and experience, service personnel of the manufacturer is able to perform the delegated tasks and to recognize and avoid possible dangers.

2.7 Personal protective equipment

Use of personal protective equipment

Personal protective equipment serves to protect staff against danger which may interfere with their health or safety at work.

- When working on and with the product, observe the occupational health and safety regulations and wear the required personal protective equipment.
- Observe the valid safety and accident prevention regulations.
- Wear protective gloves to guard against sharp edges and corners or rough surfaces.
- Wear heat-resistant protective gloves when handling hot surfaces.
- Wear protective gloves and safety goggles when handling hazardous substances.
- Wear close-fitting protective clothing and also wear long hair in a hairnet when dealing with moving components.

2.8 Notes on safe operation

Incorrect handling of the personnel

Incorrect handling and assembly may impair the product's safety and cause serious injuries and considerable material damage.

- Avoid any manner of working that may interfere with the function and operational safety of the product.
- Use the product as intended.
- Observe the safety notes and assembly instructions.
- Do not expose the product to any corrosive media. This does not apply to products that are designed for special environments.
- Eliminate any malfunction immediately.
- Observe the care and maintenance instructions.
- Observe the current safety, accident prevention and environmental protection regulations regarding the product's application field.

2.9 Transport

Handling during transport

Incorrect handling during transport may impair the product's safety and cause serious injuries and considerable material damage.

- When handling heavy weights, use lifting equipment to lift the product and transport it by appropriate means.

- Secure the product against falling during transportation and handling.
- Stand clear of suspended loads.

2.10 Malfunctions

Behavior in case of malfunctions

- Immediately remove the product from operation and report the malfunction to the responsible departments/persons.
- Order appropriately trained personnel to rectify the malfunction.
- Do not recommission the product until the malfunction has been rectified.
- Test the product after a malfunction to establish whether it still functions properly and no increased risks have arisen.

2.11 Disposal

Handling of disposal

The incorrect handling of disposal may impair the product's safety and cause serious injuries as well as considerable material and environmental harm.

- Follow local regulations on dispatching product components for recycling or proper disposal.

2.12 Fundamental dangers

General

- Observe safety distances.
- Never deactivate safety devices.
- Before commissioning the product, take appropriate protective measures to secure the danger zone.
- Disconnect power sources before installation, modification, maintenance, or calibration. Ensure that no residual energy remains in the system.
- If the energy supply is connected, do not move any parts by hand.
- Do not reach into the open mechanism or movement area of the product during operation.

2.12.1 Protection during handling and assembly

Incorrect handling and assembly

Incorrect handling and assembly may impair the product's safety and cause serious injuries and considerable material damage.

- Have all work carried out by appropriately qualified personnel.
- For all work, secure the product against accidental operation.
- Observe the relevant accident prevention rules.
- Use suitable assembly and transport equipment and take precautions to prevent jamming and crushing.

Incorrect lifting of loads

Falling loads may cause serious injuries and even death.

- Stand clear of suspended loads and do not step into their swiveling range.
- Never move loads without supervision.
- Do not leave suspended loads unattended.

2.12.2 Protection during commissioning and operation

Falling or violently ejected components

Falling and violently ejected components can cause serious injuries and even death.

- Take appropriate protective measures to secure the danger zone.
- Never step into the danger zone during operation.

2.12.3 Protection against dangerous movements

Unexpected movements

Residual energy in the system may cause serious injuries while working with the product.

- Switch off the energy supply, ensure that no residual energy remains and secure against inadvertent reactivation.
- Never rely solely on the response of the monitoring function to avert danger. Until the installed monitors become effective, it must be assumed that the drive movement is faulty, with its action being dependent on the control unit and the current operating condition of the drive. Perform maintenance work, modifications, and attachments outside the danger zone defined by the movement range.
- To avoid accidents and/or material damage, human access to the movement range of the machine must be restricted. Limit/prevent accidental access for people in this area due through technical safety measures. The protective cover and protective fence must be rigid enough to withstand the maximum possible movement energy. EMERGENCY STOP switches must be easily and quickly accessible. Before starting up the machine

or automated system, check that the EMERGENCY STOP system is working. Prevent operation of the machine if this protective equipment does not function correctly.

2.12.4 Protection against electric shock

Possible electrostatic energy

Components or assembly groups may become electrostatically charged. When the electrostatic charge is touched, the discharge may trigger a shock reaction leading to injuries.

- The operator must ensure that all components and assembly groups are included in the local potential equalisation in accordance with the applicable regulations.
- While paying attention to the actual conditions of the working environment, the potential equalisation must be implemented by a specialist electrician according to the applicable regulations.
- The effectiveness of the potential equalisation must be verified by executing regular safety measurements.

2.13 Notes on particular risks



⚠ DANGER

Risk of fatal injury from suspended loads!

Falling loads can cause serious injuries and even death.

- Stand clear of suspended loads and do not step within their swiveling range.
- Never move loads without supervision.
- Do not leave suspended loads unattended.
- Wear suitable protective equipment.



⚠ WARNING

Risk of injury from objects falling and being ejected!

Falling and ejected objects during operation can lead to serious injury or death.

- Take appropriate protective measures to secure the danger zone.



⚠ WARNING

Risk of injury due to unexpected movements!

If the power supply is switched on or residual energy remains in the system, components can move unexpectedly and cause serious injuries.

- Before starting any work on the product: Switch off the power supply and secure against restarting.
- Make sure, that no residual energy remains in the system.



⚠ WARNING

Risk of injury from crushing and impacts!

Serious injury could occur during movement of the base jaw, due to breakage or loosening of the gripper fingers or if the workpiece is lost.

- Wear suitable protective equipment.
- Do not reach into the open mechanism or the movement area of the product.



⚠ WARNING

Risk of injury from sharp edges and corners!

Sharp edges and corners can cause cuts.

- Use suitable protective equipment.



⚠ WARNING

Risk of injury from objects falling during energy supply failure

Products with a mechanical gripping force maintenance can, during energy supply failure, still move independently in the direction specified by the mechanical gripping force maintenance.

- Secure the end positions of the product with SCHUNK SDV-P pressure maintenance valves.

3 Technical Data

Connection data

Designation	Value
Pressure medium	Compressed air, compressed air quality according to ISO 8573-1:2010 [7:4:4]
Min. pressure [bar]	4
Nominal operating pressure [bar]	6
Max. pressure [bar]	6.5

Ambient conditions and operating conditions

Designation	Value
Ambient temperature [°C]	
min.	+5
max.	+90
Protection class IP *	30
Noise emission [dB(A)]	≤ 70

* For use in dirty ambient conditions (e.g. sprayed water, vapors, abrasion or processing dust) SCHUNK offers corresponding product options as standard. SCHUNK also offers customized solutions for special applications in dirty ambient conditions.

More technical data is included in the catalog data sheet. Whichever is the latest version.

4 Design and description

4.1 Configuration

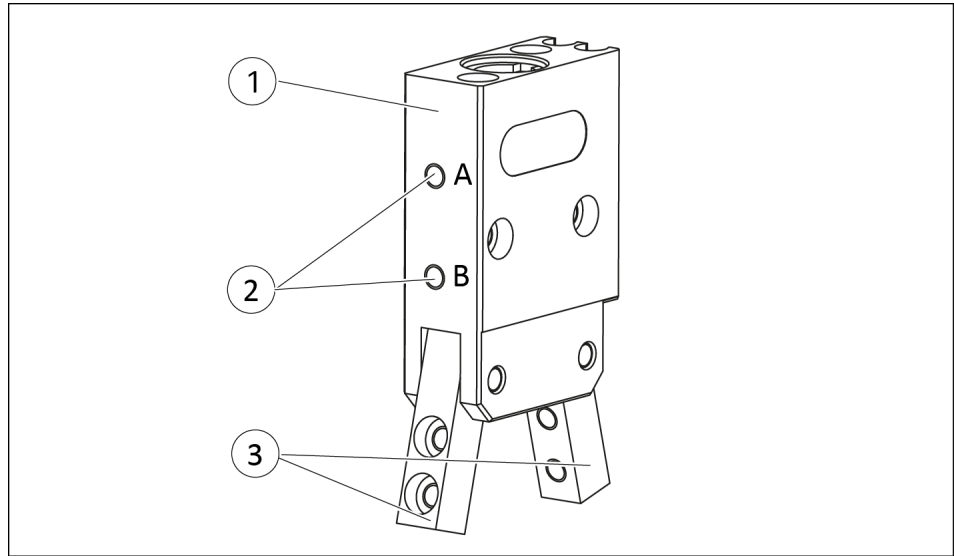

2-Finger Angular Gripper

- | | |
|---|----------------------|
| 1 | Housing |
| 2 | Main air connections |
| 2 | Base jaws |

4.2 Description

Narrow double-acting on 2-angular gripper

5 Assembly

5.1 Assembly and connection



⚠ WARNING

Risk of injury due to unexpected movements!

If the power supply is switched on or residual energy remains in the system, components can move unexpectedly and cause serious injuries.

- Before starting any work on the product: Switch off the power supply and secure against restarting.
- Make sure, that no residual energy remains in the system.

NOTICE

Damage to the gripper is possible!

If the maximum permissible finger weight or the permissible mass moment of inertia of the fingers is exceeded, the gripper can be damaged.

- A jaw movement always has to be without jerks and bounce.
- You must therefore implement sufficient reduction and/or damping.
- Observe the information in the catalog data sheet.

NOTE

- Observe the requirements for the compressed air supply, ▶ 3 [15].
- In case of compressed air loss (cutting off the energy line), the components lose their dynamic effects and do not remain in a secure position. However, the use of a SDV-P pressure maintenance valve is recommended in this case in order to maintain the dynamic effect for some time. Product variants are also offered with mechanical gripping force via springs, which also ensure a minimum clamping force in the event of a pressure drop.

1. Check the evenness of the bolting surface, ▶ 5.2 [18].
2. Connect the supply lines to the main air connections "A" and "B".
 - ⇒ Connect the air connections.
OR: Mount the throttle valve to throttle and/or damp the product sufficiently.
3. Connect the product with the machine/system, ▶ 5.2 [18].

- ⇒ If necessary, use appropriate connection elements (adapter plates).
 - ⇒ Observe the maximal tightening torque, admissible screw-in depth and, if necessary, strength class.
4. Connecting the sensor, see assembly and operating manual of the sensor.
 5. Assembling the sensor, ▶ 5.4 [📄 20].

5.2 Mechanical connection

Evenness of the mounting surface

The values apply to the whole mounting surface to which the product is mounted.

Edge length	Permissible unevenness
< 100	< 0.02
> 100	< 0.05

Tab.: Requirements for evenness of the mounting surface (Dimensions in mm)

Mounting

The centering sleeves required for centering during the fastening of the gripper and for the fixation of the gripperfingers are included in the accessories kit.

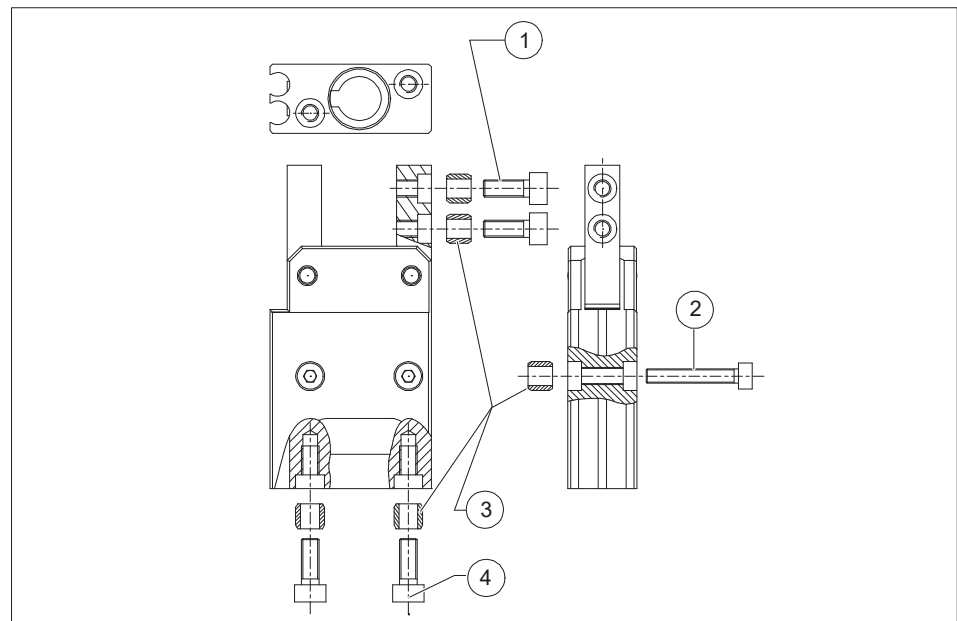

Assembly options

- | | |
|---|--|
| 1 | Finger mounting
(SWG 10 and 12 with threads and without centring) |
| 2 | Lateral gripper fastening |
| 3 | Centering sleeves for fixing |
| 4 | Gripper fastening from below |

NOTE

- For attachment from behind or lateral fix the product with the locating holes intended for this purpose.
- Secure the product with the securing holes intended for this purpose.
- Secure the top jaws with the securing holes intended for this purpose.

NOTICE

Magnetic fields and magnetisable materials can disturb the monitoring by proximity switches. Only use screws made of stainless steel for fastening the grippers (non-magnetisable screws). Fastening plates, fixing brackets etc. should not be made out of non-magnetisable materials such as aluminium or plastics.

5.3 Pneumatic connection

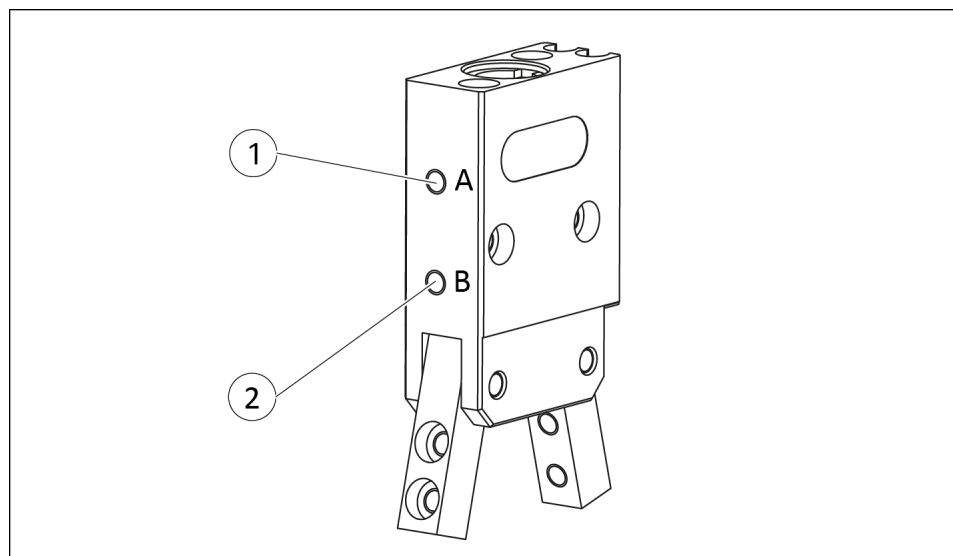

Compressed air connections

- 1 Gripper open
- 2 Gripper closed

Size	Thread diameter of the air connections
10 *	M2.5
12 *	M2.5
16	M3
20	M3
25	M3
32	M5

Size	Thread diameter of the air connections
40	M5
50	M5

* For this size, the hose clips are pre-assembled at the factory and the compressed air hoses prescribed by SCHUNK must be used, see catalog data sheet. Procedure for leaking compressed air connection, see section "Troubleshooting".

5.4 Mounting the sensor

NOTE

Observe the assembly and operating manual of the sensor for mounting and connecting.

The product is prepared for the use of sensors.

- For the exact type designations of suitable sensors, please see catalog datasheet and ▶ 5.4.1 [📄 20].
- For technical data for the suitable sensors, see assembly and operating manual and catalog datasheet.
 - The assembly and operating manual and catalog datasheet are included in the scope of delivery for the sensors and are available at [schunk.com](https://www.schunk.com).
- Information on handling sensors is available at [schunk.com](https://www.schunk.com) or from SCHUNK contact persons.

5.4.1 Overview of sensors

Size	MMS-P 22
10	⊘
12	⊘
16	✓
20	✓
25	✓
32	✓
40	✓
50	✓

5.4.2 Switch-off hysteresis MMS-P

The following table shows the lowest opening angle difference in each case that can be detected. The hysteresis values specified here apply only for the condition after teaching.

Size	Hysteresis values	
	Gripper closed	Gripper open
16	10 %	10 %
20	20 %	30 %
25	30 %	40 %
32	30 %	25 %
40	25 %	40 %
50	35 %	50 %

Calculation example: Product with an opening angle of 15° per jaw and an opening angle of 30%:

$$15^\circ \times 0.30 = 4.5^\circ$$

5.4.3 Setting dimensions

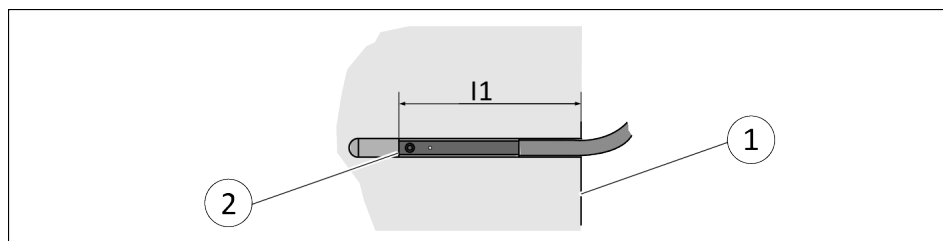

* Setting dimension l_1 , from product bottom edge (1) to front sensor (2)

For grippers of sizes 16 – 50 the adjustment dimension applies for the following sensors:

- Programmable magnetic switch MMS-P 22

Size	l_1^* [mm]
10	–
12	–
16	15.6
20	16.9
25	18.0
32	20.2
40	20.7
50	21.1

Tab.: Setting dimensions

5.4.4 Mounting programmable magnetic switch MMS-P

NOTICE

Risk of damage to the sensor during assembly!

- Observe the maximal tightening torque.

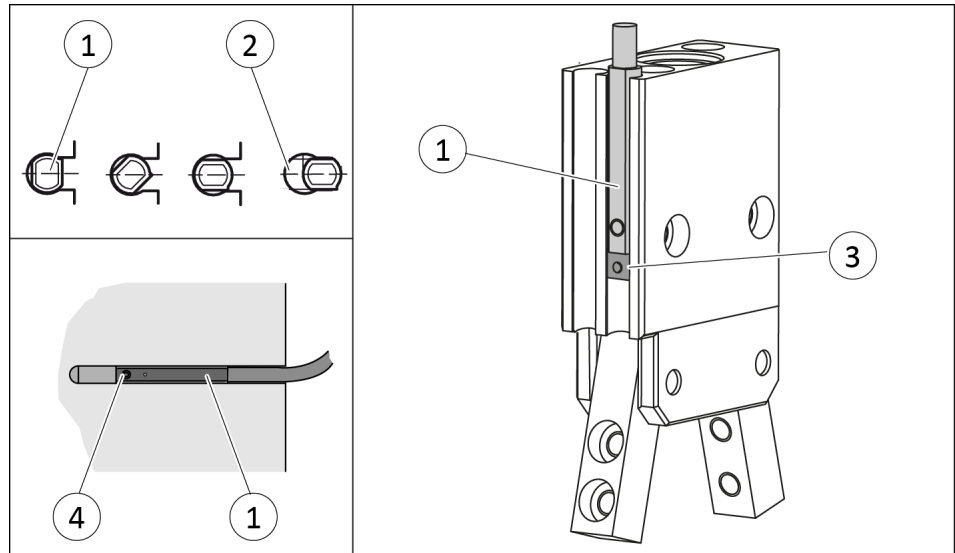

NOTE

If there is no T-nut available, slide the sensor according to dimension l1 into the groove (2), ► 5.4.3 [□ 21].

1. Turn the sensor (1) into the groove (2).
OR: Slide the sensor (1) into the groove (2) until the sensor (1) stops at the T-nut (3).
2. Secure the sensor (1) using the set-screw (4).
Tightening torque: 10 Ncm
3. Adjust sensor (1), see sensor assembly and operating manual.

6 Troubleshooting

6.1 Product does not move

Possible cause	Corrective action
Base jaws jam in housing, e.g. mounting surface is not sufficiently even.	Check the evenness of the mounting surface. ▶ 5.2 [18]
	Loosen the mounting screws of the product and actuate the product again.
Pressure drops below minimum.	Check air supply. ▶ 5.3 [19]
Compressed air lines switched.	Check compressed air lines. ▶ 5.3 [19]
Proximity switch defective or set incorrect.	Readjust or change sensor.
Unused air connections open.	Close unused air connections.
Flow control valve closed.	Open the flow control valve.
Component part defective.	Replace component or send it to SCHUNK for repair.
The aperture angle is limited to 0°.	Check opening angle limitation.

6.2 The module does not travel through the entire stroke

Possible cause	Corrective action
Dirt depositis between housing and finger.	Clean and lubricate product. ▶ 7 [25]
Pressure drops below minimum.	Check air supply. ▶ 5.3 [19]
Mounting surface is not sufficiently flat.	Check the evenness of the mounting surface. ▶ 5.2 [18]
Components have come loose e.g. due to overloading.	Send the product to SCHUNK with a repair order.

6.3 Gripping force is dropping

Possible cause	Corrective action
Compressed air can escape.	Check seals, if necessary, disassemble the product and replace seals.
Too much grease in the mechanical movement space.	Clean and lubricate product.
Pressure drops below minimum.	Check air supply. ▶ 3 [15]
Component part defective.	Replace component or send it to SCHUNK for repair.

6.4 The magnetic switch does not function

Possible cause	Corrective action
Use steel screws to mount the product.	Use VA-Screws.
Fastening plates, fixing brackets etc. made of magnetisable materials.	If possible, use aluminium or plastic.

6.5 Compressed air connection is leaking

Possible cause	Corrective action
Wrong hose.	Check hose, see catalog data sheet.
Hose gets wider if it is frequently disassembled/assembled.	Cut off hose, replace if necessary.
Hose gets wider due to external forces.	Fix hose e.g. using cable tie.

7 Maintenance

The SWG Angular Gripper cannot be repaired. The gripper cannot be disassembled for maintenance or repair works.

- A damaged gripper has to be completely replaced.

8 Translation of the original declaration of incorporation

in terms of the Directive 2006/42/EG, Annex II, Part 1 Section B.

Manufacturer/
Distributor SCHUNK SE & Co. KG
Spanntechnik | Greiftechnik | Automatisierungstechnik
Bahnhofstr. 106 – 134
D-74348 Lauffen/Neckar

We hereby declare that the partly completed machine described below

Product designation: 2-Finger Angular Gripper / SWG /pneumatic
ID number 305104 ... 305116

meets the following basic occupational health and safety of the Machinery Directive 2006/42/EC:

No. 1.1.1, No. 1.1.2, No. 1.1.3, No. 1.1.5, No. 1.3.2, No. 1.5.3, No. 1.5.4, No. 1.5.6, No. 1.5.8, No. 1.5.10, No. 1.5.11, No. 1.5.13

The partly completed machinery may not be put into operation until it has been confirmed that the machine into which the partly completed machinery is to be installed complies with the provisions of the Machinery Directive (2006/42/EC). The declaration shall be rendered invalid if modifications are made to the product.

Applied harmonized standards, especially:

EN ISO 12100:2010 Safety of machinery – General principles for design –
Risk assessment and risk reduction

The special technical documentation according to Annex VII, Part B, belonging to the partly completed machine, has been created.

Person authorized to compile the technical documentation:
Stefanie Walter, Address: see manufacturer's address

Signature: see original declaration

Lauffen/Neckar, November 2025

Dr.-Ing. Manuel Baumeister,
Head of Systems Engineering,
Technology & Innovation

9 UKCA declaration of incorporation

in accordance with the Supply of Machinery (Safety) Regulations 2008.

Manufacturer/ Distributor	SCHUNK Intec Limited Clamping and gripping technology 3 Drakes Mews, Crownhill MK8 0ER Milton Keynes
------------------------------	---

We hereby declare that on the date of the declaration the following partly completed machine complied with all basic safety and health regulations found in the "Supply of Machinery (Safety) Regulations 2008".

The declaration shall be rendered invalid if modifications are made to the product.

Product designation:	2-Finger Angular Gripper / SWG / pneumatic
ID number	305104 ... 305116

The partly completed machine may not be put into operation until it has been confirmed that the machine into which the partly completed machine is to be installed complies with the provisions of the "Supply of Machinery (Safety) Regulations 2008".

Applied harmonized standards, especially:

EN ISO 12100:2010	Safety of machinery – General principles for design – Risk assessment and risk reduction
-------------------	---

The special technical documentation according to Annex VII, Part B, belonging to the partly completed machine, has been created.

Person authorized to compile the technical documentation:
Marcel Machado, address: refer to manufacturer's address



Lauffen/Neckar, November 2025

Dr.-Ing. Manuel Baumeister,
Head of Systems Engineering,
Technology & Innovation



SCHUNK SE & Co. KG
Spanntechnik | Greiftechnik | Automatisierungstechnik

Bahnhofstr. 106 - 134
D-74348 Lauffen/Neckar
Tel. +49-7133-103-0
info@de.schunk.com
schunk.com

Folgen Sie uns | *Follow us*



Wir drucken nachhaltig | *We print sustainable*