



Assembly and Operating Manual

RM-W

Swivel unit

Original operating manual

Hand in hand for tomorrow

Imprint

Copyright:

This manual is protected by copyright. The author is SCHUNK SE & Co. KG.
All rights reserved.

Technical changes:

We reserve the right to make alterations for the purpose of technical improvement.

Document number: 389388

Version: 11.00 | 25/09/2025 | en

Dear Customer,

Thank you for trusting our products and our family-owned company, the leading technology supplier of robots and production machines.

Our team is always available to answer any questions on this product and other solutions. Ask us questions and challenge us. We will find a solution!

Best regards,

Your SCHUNK team

Customer Management

Tel. +49-7133-103-2503

Fax +49-7133-103-2189

cmg@de.schunk.com



Please read the operating manual in full and keep it close to the product.

Table of Contents

1 General	5
1.1 About this manual.....	5
1.1.1 Presentation of Warning Labels	5
1.1.2 Symbol definition.....	6
1.1.3 Applicable documents	6
1.1.4 Sizes.....	6
1.1.5 Variants	6
1.2 Warranty	6
1.3 Scope of delivery.....	6
1.4 Accessories	7
1.4.1 Sealing kit	7
1.4.2 Sensors	7
2 Basic safety notes	8
2.1 Intended use.....	8
2.2 Not intended use	8
2.3 Constructional changes.....	8
2.4 Environmental and operating conditions.....	9
2.5 Personnel qualification	9
2.6 Personal protective equipment	10
2.7 Notes on safe operation.....	10
2.8 Transport.....	10
2.9 Malfunctions	11
2.10 Disposal	11
2.11 Fundamental dangers	11
2.11.1 Protection during handling and assembly	11
2.11.2 Protection during commissioning and operation	12
2.11.3 Protection against dangerous movements	12
2.12 Notes on particular risks	13
3 Technical data	14
4 Assembly and settings	15
4.1 Mechanical connection.....	16
4.2 Air connections.....	17
4.3 Adjusting the end positions.....	18
4.4 End position monitoring.....	20
5 Start-up	21

6 Troubleshooting	22
6.1 Product does not move.....	22
6.2 Product does not travel through the rotating angle	22
6.3 End position signal not present.....	22
6.4 Torque is diminishing	22
6.5 Product rotates abruptly	23
6.6 Product does not move smoothly to the end positions	23
7 Maintenance	24
7.1 Shock absorber	24
7.2 Maintenance interval	24
7.3 Lubricants/Lubrication points (basic lubrication)	25
7.4 Dismantling the product	26
7.5 Assembling the product	27
8 Assembly drawing	28
9 Translation of the original declaration of incorporation	29
10 UKCA declaration of incorporation	30
11 Information on the RoHS Directive, REACH Regulation and Substances of Very High Concern (SVHC)	31

1 General

1.1 About this manual

This manual contains important information for a safe and appropriate use of the product.

This manual is an integral part of the product and must be kept accessible for the personnel at all times.

Before starting work, the personnel must have read and understood this operating manual. Prerequisite for safe working is the observance of all safety instructions in this manual.

In addition to these instructions, the documents listed under ▶ 1.1.3 [6] are applicable.

NOTE: The illustrations in this manual are intended to provide a basic understanding and may deviate from the actual version.

1.1.1 Presentation of Warning Labels

To make risks clear, the following signal words and symbols are used for safety notes.



⚠ DANGER

Dangers for persons!

Non-observance will inevitably cause irreversible injury or death.



⚠ WARNING

Dangers for persons!

Non-observance can lead to irreversible injury and even death.



⚠ CAUTION

Dangers for persons!

Non-observance can cause minor injuries.

NOTICE

Material damage!

Information about avoiding material damage.

1.1.2 Symbol definition

The following symbols are used in this manual:

- Prerequisite for an action

1. Action 1

2. Action 2

⇒ Intermediate results

⇒ Final results

▶ 1.1.2 [📄 6]: chapter number and [page number] in hyperlinks

1.1.3 Applicable documents

- General terms of business *
- Catalog data sheet of the purchased product *
- "GEMOTEC TOOLBOX Rotation" program *

The documents labeled with an asterisk (*) can be downloaded from schunk.com/downloads.

1.1.4 Sizes

This operating manual applies to the following sizes:

- RM-W 50
- RM-W 110
- RM-W 200
- RM-W 310

1.1.5 Variants

This operating manual applies to the following variations:

- RM-W with soft shock absorbers (-1)
- RM-W with hard shock absorbers (-2)

1.2 Warranty

If the product is used as intended, the warranty is valid for 24 months from the ex-works delivery date under the following conditions:

- Observe the specified maintenance and lubrication intervals
- Observe the ambient conditions and operating conditions

Parts touching the workpiece and wear parts are not included in the warranty.

1.3 Scope of delivery

The scope of delivery includes

- Swivel unit RM in the version ordered
- Exhaust air throttles
- Accessory pack

1.4 Accessories

The following accessories, which must be ordered separately, are required for the product:

- End-position monitoring
- Sensors

For information regarding which accessory articles can be used with the corresponding product variants, see catalog data sheet.

1.4.1 Sealing kit

Spare parts for complete swivel drive (seals cannot be replaced individually)	ID number
RM 50	5519598
RM 110	5519599
RM 200	5519600
RM 310	5519601

Tab.: ID.-No. of the seal kit

1.4.2 Sensors

Designation	Type
Inductive proximity switches	IN, NI
Monitoring set	GMNS...

- Exact type designation of the compatible sensors see catalog.
- Information on handling sensors is available at schunk.com or from SCHUNK contact persons.

2 Basic safety notes

2.1 Intended use

The product may only be used for swiveling permissible attachment parts or workpieces.

- The product may only be used within the scope of its technical data, ▶ 3 [14].
- When implementing and operating components in safety-related parts of the control systems, the basic safety principles in accordance with DIN EN ISO 13849-2 apply. The proven safety principles in accordance with DIN EN ISO 13849-2 also apply to categories 1, 2, 3 and 4.
- The product is intended for installation in a machine/ automated system. The applicable guidelines for the machine/ automated system must be observed and complied with.
- The product is intended for industrial and industry-oriented use.
- Appropriate use of the product includes compliance with all instructions in this manual.

2.2 Not intended use

It is not intended use if the product is used, for example, as a pressing tool, stamping tool, lifting gear, guide for tools, cutting tool, clamping device or a drilling tool.

- Any utilization that exceeds or differs from the appropriate use is regarded as misuse.

2.3 Constructional changes

Implementation of structural changes

Modifications, changes or reworking, e.g. additional threads, holes, or safety devices, can damage the product or impair its functionality or safety.

- Structural changes should only be made with the written approval of SCHUNK.

2.4 Environmental and operating conditions

Required ambient conditions and operating conditions

Incorrect ambient and operating conditions can make the product unsafe, leading to the risk of serious injuries, considerable material damage and/or a significant reduction to the product's life span.

- Make sure that the product is not exposed to excessive vibrations and/or strokes.
- Ensure that no strong magnetic fields impair the function of the product.

Contact your SCHUNK partner if the product is to be used in strong magnetic fields.

2.5 Personnel qualification

Inadequate qualifications of the personnel

If the personnel working with the product is not sufficiently qualified, the result may be serious injuries and significant property damage.

- All work may only be performed by qualified personnel.
- Before working with the product, the personnel must have read and understood the complete assembly and operating manual.
- Observe the national safety regulations and rules and general safety instructions.

The following personal qualifications are necessary for the various activities related to the product:

Trained electrician

Due to their technical training, knowledge and experience, trained electricians are able to work on electrical systems, recognize and avoid possible dangers and know the relevant standards and regulations.

Qualified personnel

Due to its technical training, knowledge and experience, qualified personnel is able to perform the delegated tasks, recognize and avoid possible dangers and knows the relevant standards and regulations.

Instructed person

Instructed persons were instructed by the operator about the delegated tasks and possible dangers due to improper behaviour.

Service personnel of the manufacturer

Due to its technical training, knowledge and experience, service personnel of the manufacturer is able to perform the delegated tasks and to recognize and avoid possible dangers.

2.6 Personal protective equipment

Use of personal protective equipment

Personal protective equipment serves to protect staff against danger which may interfere with their health or safety at work.

- When working on and with the product, observe the occupational health and safety regulations and wear the required personal protective equipment.
- Observe the valid safety and accident prevention regulations.
- Wear protective gloves to guard against sharp edges and corners or rough surfaces.
- Wear heat-resistant protective gloves when handling hot surfaces.
- Wear protective gloves and safety goggles when handling hazardous substances.
- Wear close-fitting protective clothing and also wear long hair in a hairnet when dealing with moving components.

2.7 Notes on safe operation

Incorrect handling of the personnel

Incorrect handling and assembly may impair the product's safety and cause serious injuries and considerable material damage.

- Avoid any manner of working that may interfere with the function and operational safety of the product.
- Use the product as intended.
- Observe the safety notes and assembly instructions.
- Do not expose the product to any corrosive media. This does not apply to products that are designed for special environments.
- Eliminate any malfunction immediately.
- Observe the care and maintenance instructions.
- Observe the current safety, accident prevention and environmental protection regulations regarding the product's application field.

2.8 Transport

Handling during transport

Incorrect handling during transport may impair the product's safety and cause serious injuries and considerable material damage.

- When handling heavy weights, use lifting equipment to lift the product and transport it by appropriate means.

- Secure the product against falling during transportation and handling.
- Stand clear of suspended loads.

2.9 Malfunctions

Behavior in case of malfunctions

- Immediately remove the product from operation and report the malfunction to the responsible departments/persons.
- Order appropriately trained personnel to rectify the malfunction.
- Do not recommission the product until the malfunction has been rectified.
- Test the product after a malfunction to establish whether it still functions properly and no increased risks have arisen.

2.10 Disposal

Handling of disposal

The incorrect handling of disposal may impair the product's safety and cause serious injuries as well as considerable material and environmental harm.

- Follow local regulations on dispatching product components for recycling or proper disposal.

2.11 Fundamental dangers

General

- Observe safety distances.
- Never deactivate safety devices.
- Before commissioning the product, take appropriate protective measures to secure the danger zone.
- Disconnect power sources before installation, modification, maintenance, or calibration. Ensure that no residual energy remains in the system.
- If the energy supply is connected, do not move any parts by hand.
- Do not reach into the open mechanism or movement area of the product during operation.

2.11.1 Protection during handling and assembly

Incorrect handling and assembly

Incorrect handling and assembly may impair the product's safety and cause serious injuries and considerable material damage.

- Have all work carried out by appropriately qualified personnel.
- For all work, secure the product against accidental operation.
- Observe the relevant accident prevention rules.
- Use suitable assembly and transport equipment and take precautions to prevent jamming and crushing.

Incorrect lifting of loads

Falling loads may cause serious injuries and even death.

- Stand clear of suspended loads and do not step into their swiveling range.
- Never move loads without supervision.
- Do not leave suspended loads unattended.

2.11.2 Protection during commissioning and operation

Falling or violently ejected components

Falling and violently ejected components can cause serious injuries and even death.

- Take appropriate protective measures to secure the danger zone.
- Never step into the danger zone during operation.

2.11.3 Protection against dangerous movements

Unexpected movements

Residual energy in the system may cause serious injuries while working with the product.

- Switch off the energy supply, ensure that no residual energy remains and secure against inadvertent reactivation.
- Never rely solely on the response of the monitoring function to avert danger. Until the installed monitors become effective, it must be assumed that the drive movement is faulty, with its action being dependent on the control unit and the current operating condition of the drive. Perform maintenance work, modifications, and attachments outside the danger zone defined by the movement range.
- To avoid accidents and/or material damage, human access to the movement range of the machine must be restricted. Limit/prevent accidental access for people in this area due through technical safety measures. The protective cover and protective fence must be rigid enough to withstand the maximum possible movement energy. EMERGENCY STOP switches must be easily and quickly accessible. Before starting up the machine

or automated system, check that the EMERGENCY STOP system is working. Prevent operation of the machine if this protective equipment does not function correctly.

2.12 Notes on particular risks



⚠ WARNING

Risk of injury from objects falling and being ejected!

Falling and ejected objects during operation can lead to serious injury or death.

- Take appropriate protective measures to secure the danger zone.



⚠ WARNING

Risk of injury from rotating components!

In the case of swivel units or rotary tables with a rotary drive, serious injuries can be caused by rotating components.

- Take appropriate protective measures to secure the danger zone.

3 Technical data

Tab.:

Module type	RM50-310 W90	RM50-310 W180
Standard angle of rotation [°] *	90	180
End position adjustability [°]		± 5
Ambient temperature [°C]		5 – 60
IP rating		40
Noise emission [dB(A)]		≤ 70
Pressure medium	Compressed air, compressed air quality according to ISO 8573-1:2010 [7:4:4]	
Min. pressure [bar]		3
Max. pressure [bar]		8
Nominal working pressure [bar]		6

* All other angles of rotation between 5 and 180 degrees can be selected – specify when ordering –  catalog.

More technical data is included in the catalog data sheet. Whichever is the latest version.

4 Assembly and settings

NOTICE

Material damage due to pressure loss!

On delivery, the lock nuts for end position and absorber adjustment are only hand-tightened. This could lead to a loss in pressure and cause considerable material damage.

- Tighten the lock nuts for end position and shock absorber adjustment before commissioning.

NOTICE

Material damage due to improper assembly!

- When mounting loads, do not allow impermissible forces and moments to be exerted (see catalog data sheet).
- Select a suitable tightening torque when assembling the product or loads on the product in accordance with the generally accepted guidelines for screw connections.
- Secure all screws using a suitable chemical screw lock.

4.1 Mechanical connection

Evenness of the mounting surface

The values apply to the whole mounting surface to which the product is mounted.

Edge length	Permissible unevenness
< 100	< 0.02
> 100	< 0.05

Tab.: Requirements for evenness of the mounting surface (Dimensions in mm)

Connections at the housing

The connection geometries are above, below and at the side of the rotary module.

Dimensions for the position and size of the connection geometries, Catalog data sheet of the product .

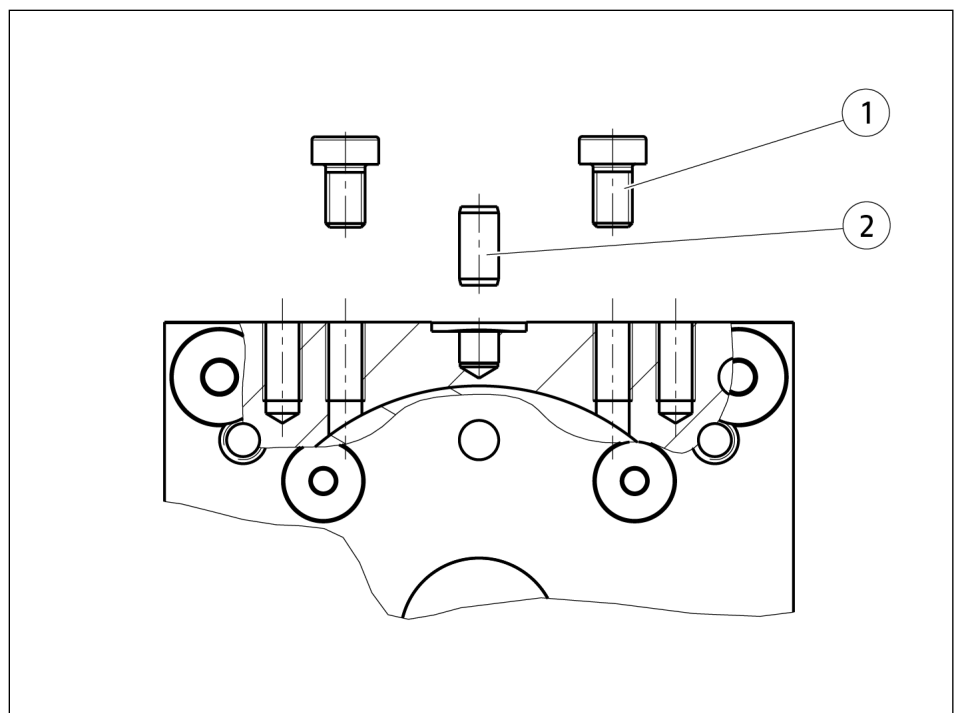

Connections at the housing

Item	Mounting	Size			
		50	110	200	310
1	Mounting screw	M5	M5	M5	M8
	Max. depth of engagement from locating surface [mm]	8	10	10	12
2	Centering pin	Ø5	Ø5	Ø5	Ø5

Mounting

1. When fastening the product from the rear or side, use the fixing bores provided.
2. Fasten the product using the mounting holes provided for this purpose.

4.2 Air connections

NOTICE

Damage to the rotary module possible!

The rotary module can be damaged if it arrives too abruptly in the end position.

- The rotary motion must reach the end position without jerk or bounce.
- Therefore, shock absorbers must be used ▶ 4.3 [18].
- Please observe the information in the catalog pages.

NOTICE

Pressure medium:

The unit must not under any circumstances be operated with oiled air before operation with unoiled air (washing out of factory lubrication).

NOTICE

Observe the requirements for the air supply, ▶ 3 [14].

Use connecting wires with the same or a larger cross-section as the connection thread.

See the catalog for precise information about the position and size of the connection geometries.

4.3 Adjusting the end positions

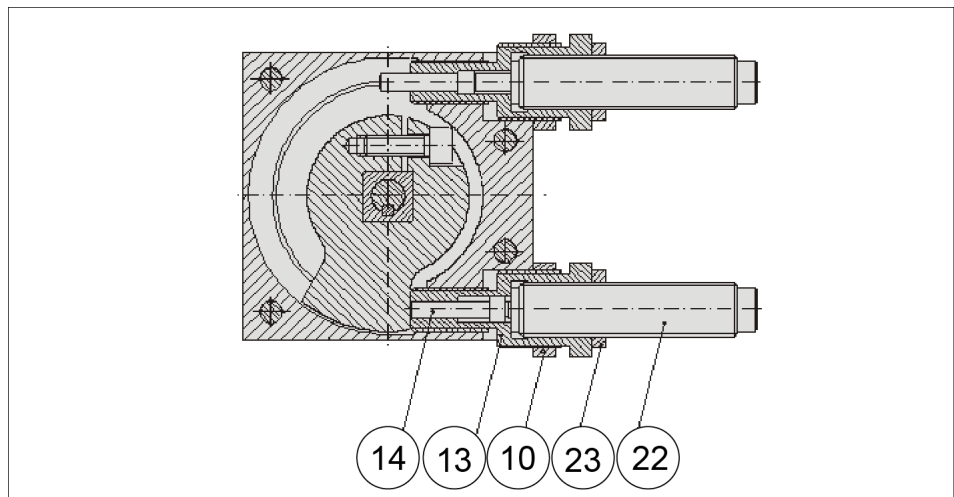

Adjusting the end positions

The parts listed below are included within the scope of delivery of every rotary module for angle of rotation fine adjustment and adjustment of the end position dampening to the mass moment of inertia occurring in operation.

- Counter nut (10)
- Stop coupling (13)
- Rod (14)
- Shock absorber (22)
- Counter nut (23)

Angle of rotation fine adjustment

1. Release counter nut (10).
2. By twisting the stop coupling (13) with the rod (14) and shock absorber (22) that are integrated in it, the angle of rotation in both end positions can be set by $\pm 5^\circ$ from the nominal angle of rotation. The nominal rotation angle has to be specified for the order and can be selected without steps between 5° and 180° . Standard angles are 90° and 180° .
3. Tighten the stop coupling again with the counter nut.

Damping adjustment

NOTICE

Use the shock absorber!

Operation without the shock absorber included within the scope of delivery is not permitted.

- Observe the maximum mass moment of inertia (catalog data).
- Adjust the dampening at the mass moment of inertia.

- The desired angle of rotation has been set.
 1. Release counter nut (23).
 2. By turning the shock absorber (22) in and out, the stroke of the shock absorber (and therefore the shock absorber characteristic curve) can be adjusted to the mass moment of inertia occurring in operation. The previously adjusted angle of rotation is not influenced by this.
 3. Tighten the absorber again with the counter nut.

4.4 End position monitoring

To monitor the end positions, standardized monitoring sets for direct installation are available.

The stop level that is integrated in the rotary module is directly monitored.

Proximity switch – monitoring set: GMNS-...

Scope of delivery of the monitoring set:

- 1 x retaining plate
- 1 x Inductive proximity switch
- 1 x connection cable

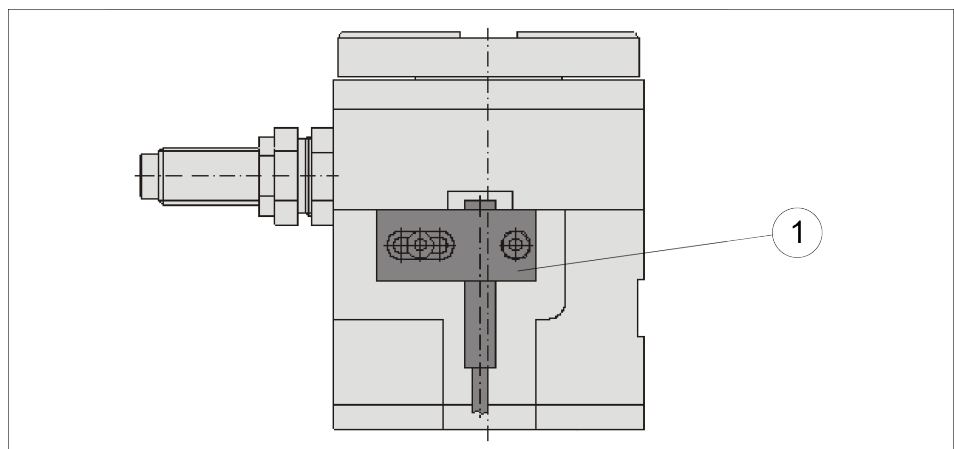

Position of the proximity switches

- 1 Proximity switch (GMNS-... installation on both sides)

Setting the monitoring

1. Undo the attachment screw.
2. Set the sensor via the retainer plate.
3. Fix the sensor via the attachment screw.

5 Start-up

- Check the technical specifications ▶ 3 [14].
- Check the permissible loading specifications (see catalog).
- Do not use the product until trouble-free operation has been checked taking all permissible operating parameters into account.
- Set the speed of the movement in such a way that the permitted swiveling time is not exceeded. Use the "Gemotec Toolbox" program for calculation (www.schunk.com).
- The movement speed is ideally regulated via throttle check valves ▶ 4.2 [17]. The speed is always set so that it starts at a low speed and increases to a higher speed until the desired operating speed has been reached.
- Operate the device in such a way that the permissible cycle number per minute is not exceeded. Use the "Gemotec Toolbox" program for calculation (www.schunk.com).

6 Troubleshooting

6.1 Product does not move

Possible cause	Corrective action
Pressure drops below minimum.	Check air supply. ▶ 4.2 [17]
Compressed air lines switched.	Check compressed air lines.
Proximity switch defective or set incorrect.	Readjust or change sensor.
Unused air connections open.	Close unused air connections.
Flow control valve closed.	Open the flow control valve.

6.2 Product does not travel through the rotating angle

Possible cause	Corrective action
End positions are adjusted incorrectly.	Adjust end position.Link Endlagen
Pressure drops below minimum.	Check air supply.▶ 4.2 [17]
Mounting surface is not sufficiently flat.	Check the evenness of the mounting surface.▶ 4.1 [16]
Component part defective.	Send product with a SCHUNK repair order or dismantle product.
Shock absorber defective.	Check or, if need be, replace the shock absorber. Adjust end position.Link Endlagen

6.3 End position signal not present

Possible cause	Corrective action
Proximity switch defective or set incorrect.	Adjust sensor or if necessary change sensor., Link Endlagen
Cable breakage.	Change sensor.

6.4 Torque is diminishing

Possible cause	Corrective action
Seals of the drive piston defective.	Send product with a SCHUNK repair order or dismantle product. Replace the seals.
Positioning of the swivel table defective.	Send product with a SCHUNK repair order or dismantle product.
Compressed air lines blocked.	Check compressed air lines of damage.
Pressure drops below minimum.	Check air supply. ▶ 4.2 [17]

6.5 Product rotates abruptly

Possible cause	Corrective action
Seals of the drive piston defective.	Send product with a SCHUNK repair order or dismantle product. Replace the seals of the drive piston.
Positioning of the swivel table defective.	Send product with a SCHUNK repair order or dismantle product.
Compressed air lines blocked.	Check compressed air lines of damage.

6.6 Product does not move smoothly to the end positions

Possible cause	Corrective action
Fine adjustment of the absorber stroke is faulty.	Adjust absorber stroke. ▶ 4.3 [18]
Absorber defective.	Replace and readjust absorbers. ▶ 4.3 [18]
Exhaust throttle defective.	Replacing the exhaust air throttle.
Speed of rotation too high.	Setting the exhaust air throttle.

7 Maintenance

7.1 Shock absorber

NOTICE

Serious mechanical damage due to failure of the shock absorbers.

The shock absorbers have a limited service life span. A shock absorber failure can lead to serious mechanical damage; for this reason, they must be checked regularly for proper function. The shock absorber is working correctly if the device reaches its end position swiftly without any mechanical impact.

Overloading of the unit or exceeding the permitted swivel speed can lead to drastic reduction of the service life.

- Determine the swiveling times and the permitted stroke frequency with "Gemotec Toolbox".
- Regularly check the shock absorber.
- Observe the recommended maintenance intervals.

7.2 Maintenance interval

NOTICE

Material damage due to hardening lubricants!

Lubricants harden more quickly at temperatures above 60°C, leading to possible product damage.

- Reduce the lubricant intervals accordingly.

Interval [Mio. cycles]	2
------------------------	---

7.3 Lubricants/Lubrication points (basic lubrication)

- All module bearings are life-time lubricated and do not need to be re-lubricated.
- When disassembling the module for repairs, all bearings have to be cleaned and re-lubricated.

During maintenance, treat all greased areas with lubricant. Thinly apply lubricant with a lint-free cloth.

SCHUNK recommends the lubricants listed.

Greasing area	Lubricant
Rolling elements and sliding surfaces of the bearings (only after disassembling the module for repairs)	SCHUNK grease 10

Details regarding SCHUNK lubricant designations are available at [schunk.com/lubricants](https://www.schunk.com/lubricants).

The product contains food-compliant lubricants and non-food-compliant lubricants as standard.

Components such as rolling bearings, linear guides, or shock absorbers are not provided with food-compliant lubricants.

The requirements of standard EN 1672-2:2020 are not fully met.

NOTE

- Change contaminated food-compliant lubricant.
 - Observe information in the safety data sheet from the lubricant manufacturer.
-

7.4 Dismantling the product

NOTICE

A high degree of expertise is required for the disassembly and assembly of the module, ▶ 2.5 [9].

The repair or elimination of defects by the customer on the module results in the termination of the warranty and liability for all resulting warranty and subsequent damage.

- It is recommended to have SCHUNK repair damaged and defective modules.
- Disassemble the product as shown in the "Assembly drawings", ▶ 8 [28].
- **Only disassemble the product for repair purposes.**



⚠ WARNING

Risk of injury due to unexpected movements!

If the power supply is switched on or residual energy remains in the system, components can move unexpectedly and cause serious injuries.

- Before starting any work on the product: Switch off the power supply and secure against restarting.
- Make sure, that no residual energy remains in the system.

7.5 Assembling the product

Maintenance

- Clean all parts thoroughly and check for damage and wear.
- Treat all greased areas with lubricant. ▶ 7.3 [📄 25]
- Oil or grease bare external steel parts.

Assembly

Assembly takes place in the opposite order to disassembly.
Observe the following:

- Unless otherwise specified, secure all screws and nuts with Loctite no. 243 and tighten with the appropriate tightening torque.
Select suitable tightening torques for screws when assembling the product in accordance with the generally accepted guidelines for screw connections.

8 Assembly drawing

The following figure is an example image.
It serves for illustration and assignment of the spare parts.
Variations are possible depending on size and variant.

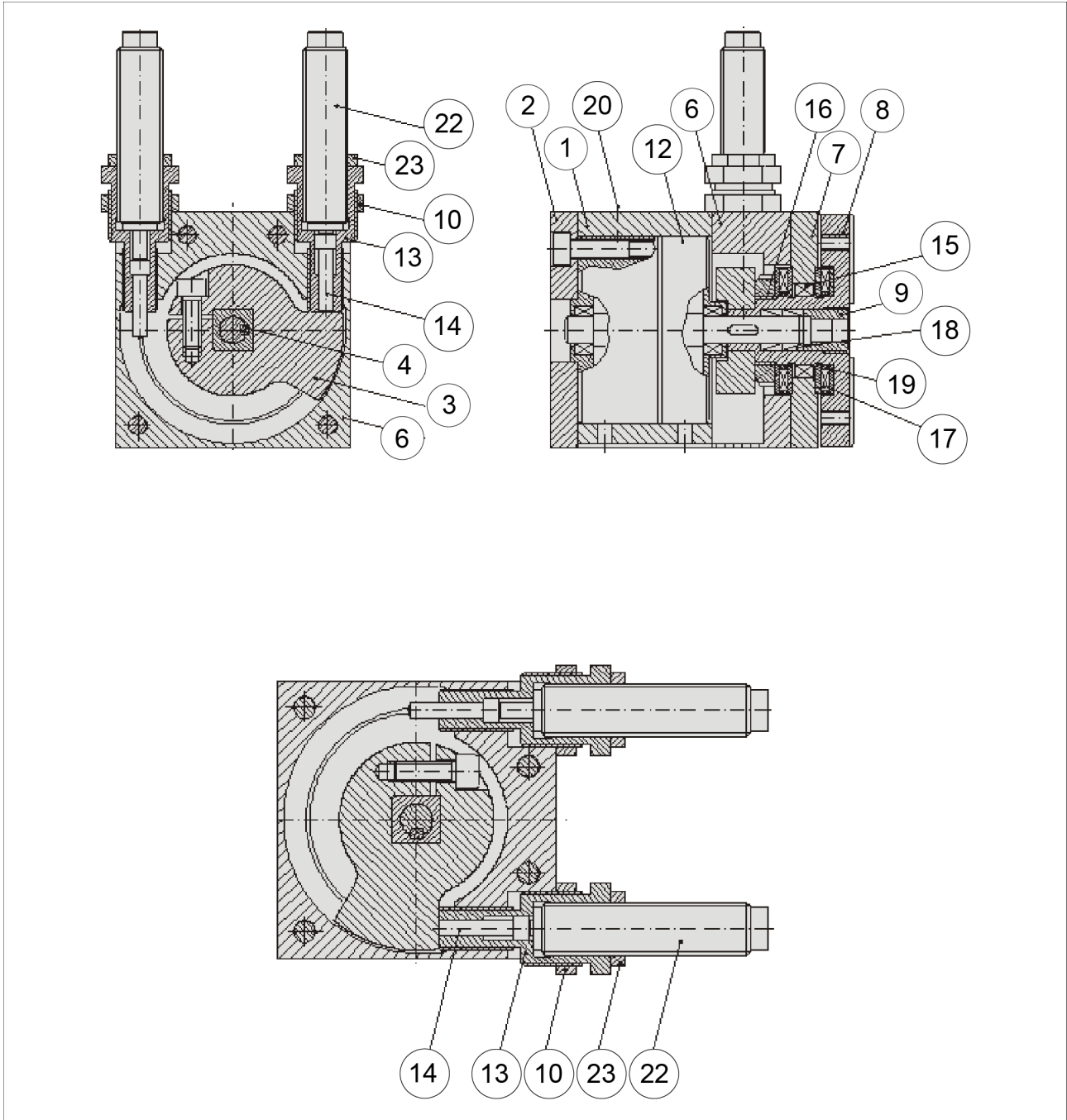

Assembly of RM 06

9 Translation of the original declaration of incorporation

in terms of the Directive 2006/42/EG, Annex II, Part 1 Section B.

Manufacturer/
Distributor SCHUNK SE & Co. KG
Spanntechnik | Greiftechnik | Automatisierungstechnik
Bahnhofstr. 106 – 134
D-74348 Lauffen/Neckar

We hereby declare that the partly completed machine described below

Product designation: Swivel unit / RM-W /pneumatic
ID number 0313003 ... 0313997

meets the following basic occupational health and safety of the Machinery Directive 2006/42/EC:

No. 1.1.1, No. 1.1.2, No. 1.1.3, No. 1.1.5, No. 1.3.2, No. 1.5.3, No. 1.5.4, No. 1.5.6, No. 1.5.8, No. 1.5.10, No. 1.5.11, No. 1.5.13

The partly completed machinery may not be put into operation until it has been confirmed that the machine into which the partly completed machinery is to be installed complies with the provisions of the Machinery Directive (2006/42/EC). The declaration shall be rendered invalid if modifications are made to the product.

Applied harmonized standards, especially:

EN ISO 12100:2010 Safety of machinery – General principles for design –
Risk assessment and risk reduction

The special technical documentation according to Annex VII, Part B, belonging to the partly completed machine, has been created.

Person authorized to compile the technical documentation:
Stefanie Walter, Address: see manufacturer's address

Signature: see original declaration

Lauffen/Neckar, September 2025

Dr.-Ing. Manuel Baumeister,
Head of Systems Engineering,
Technology & Innovation

11 Information on the RoHS Directive, REACH Regulation and Substances of Very High Concern (SVHC)

RoHS Directive

SCHUNK products are classified as "large-scale stationary installations" or as "large-scale stationary industrial tools" within the meaning of Directive 2011/65/EU and its extension 2015/863/EU "on the restriction of the use of certain hazardous substances in electrical and electronic equipment (RoHS)", or fulfill their intended function only as part of one. Therefore products from SCHUNK do not fall within the scope of the directive at this time.

REACH Regulation

Products from SCHUNK fully comply with the regulations of Regulation (EC) No. 1907/2006 "concerning the Registration, Evaluation, Authorization and Restriction of Chemicals (REACH)" and its amendment 2022/477. SCHUNK attaches great importance to completely avoiding chemicals of concern to humans and the environment wherever possible.

Only in rare exceptional cases do SCHUNK products contain SVHC substances on the candidate list with a mass content above 0.1%. In accordance with Article. 33 (1) of Regulation (EC) No. 1907/2006, SCHUNK complies with its duty to "communicate information on substances in articles" and lists the components concerned and the substances used in an overview that can be viewed at schunk.com/SVHC.

Signature: see original declaration

Lauffen/Neckar, September 2025

Dr.-Ing. Manuel Baumeister,
Head of Systems Engineering,
Technology & Innovation



SCHUNK SE & Co. KG
Spanntechnik | Greiftechnik | Automatisierungstechnik

Bahnhofstr. 106 - 134
D-74348 Lauffen/Neckar
Tel. +49-7133-103-0
info@de.schunk.com
schunk.com

Folgen Sie uns | *Follow us*



Wir drucken nachhaltig | *We print sustainable*