



# Assembly and operating manual

## SFL

### Vane Swivel Unit

Translation of Original Operating  
Manual

## Imprint

### Copyright:

This manual is protected by copyright. The author is SCHUNK SE & Co. KG.  
All rights reserved.

### Technical changes:

We reserve the right to make alterations for the purpose of technical improvement.

**Document number:** 389398

**Version:** 10.00 | 16/02/2026 | en

Dear Customer,

Thank you for trusting our products and our family-owned company, the leading technology supplier of robots and production machines.

Our team is always available to answer any questions on this product and other solutions. Ask us questions and challenge us. We will find a solution!

Best regards,

Your SCHUNK team

Customer Management

Tel. +49-7133-103-2503

Fax +49-7133-103-2189

cmg@de.schunk.com



**Please read the operating manual in full and keep it close to the product.**

## Table of Contents

<b>1</b>	<b>General .....</b>	<b>5</b>
1.1	About this manual.....	5
1.1.1	Presentation of Warning Labels .....	5
1.1.2	Applicable documents .....	6
1.1.3	Sizes.....	6
1.1.4	Variants .....	6
1.2	Warranty .....	6
1.3	Scope of delivery.....	7
1.3.1	Accessory pack.....	7
1.4	Accessories .....	7
1.4.1	Sealing kit .....	7
<b>2</b>	<b>Basic safety notes .....</b>	<b>8</b>
2.1	Intended use.....	8
2.2	Not intended use .....	8
2.3	Constructional changes.....	8
2.4	Spare parts .....	9
2.5	Ambient conditions and operating conditions .....	9
2.6	Personnel qualification .....	9
2.7	Personal protective equipment .....	10
2.8	Notes on safe operation.....	10
2.9	Transport.....	10
2.10	Malfunctions.....	11
2.11	Disposal .....	11
2.12	Fundamental dangers .....	11
2.12.1	Protection during handling and assembly .....	11
2.12.2	Protection during commissioning and operation .....	12
2.12.3	Protection against dangerous movements .....	12
2.12.4	Protection against electric shock.....	13
2.13	Notes on particular risks .....	14
<b>3</b>	<b>Technical data .....</b>	<b>15</b>
3.1	Type key.....	15
3.2	Basic data .....	15
<b>4</b>	<b>Design and description .....</b>	<b>17</b>
4.1	Configuration .....	17
4.2	Description .....	17
<b>5</b>	<b>Assembly.....</b>	<b>18</b>
5.1	Assembling and connecting.....	18

5.2	Connections .....	20
5.2.1	Mechanical connection .....	20
5.2.2	Pneumatic connection .....	22
5.2.3	Design suggestion for adapter plate .....	23
5.3	Mounting the sensor .....	25
5.3.1	Overview of sensors .....	25
5.3.2	Assembling the magnetic switch MMS 22 .....	25
<b>6</b>	<b>Commissioning .....</b>	<b>27</b>
6.1	Checking opening and closing intervals.....	27
6.2	Adjusting the swivel angle .....	27
6.2.1	Overview of the swivel angle range .....	27
6.2.2	Adjusting the swivel angle for the E variant .....	29
6.2.3	Adjusting the swivel angle for the S variant .....	30
6.3	Restart after long standstill .....	31
<b>7</b>	<b>Troubleshooting.....</b>	<b>32</b>
7.1	Product does not achieve the opening and closing times .....	32
7.2	Swivel movement is not executed immediately.....	32
7.3	The product is not moving smoothly into the end positions.....	33
7.4	The product is not performing the full stroke .....	33
7.5	The product is swivelling abruptly.....	33
7.6	The product is not moving.....	33
7.7	Torque is diminishing .....	34
<b>8</b>	<b>Maintenance .....</b>	<b>35</b>
8.1	Notes.....	35
8.2	Maintenance interval .....	35
8.3	Lubricants/Lubrication points (basic lubrication) .....	36
8.4	Replacing an elastomer for E variants .....	37
8.5	Replacing a shock absorber for S variants .....	38
8.6	Disassembling the swivel unit.....	39
8.7	Assembling the swivel unit.....	41
8.8	Screw and nut tightening torques.....	43
8.9	Assembly drawings .....	43
8.9.1	Assembly drawing of the basic modules .....	43
8.9.2	SFL assembly drawing .....	44
<b>9</b>	<b>Translation of the original declaration of incorporation .....</b>	<b>45</b>
<b>10</b>	<b>UKCA declaration of incorporation .....</b>	<b>46</b>
<b>11</b>	<b>Information on the RoHS Directive, REACH Regulation and Substances of Very High Concern (SVHC) .....</b>	<b>47</b>

# 1 General

## 1.1 About this manual

This manual contains important information for a safe and appropriate use of the product.

This manual is an integral part of the product and must be kept accessible for the personnel at all times.

Before starting work, the personnel must have read and understood this operating manual. Prerequisite for safe working is the observance of all safety instructions in this manual.

In addition to these instructions, the documents listed under Link Mitgeltende Unterlagen are applicable.

**NOTE:** The illustrations in this manual are intended to provide a basic understanding and may deviate from the actual version.

### 1.1.1 Presentation of Warning Labels

To make risks clear, the following signal words and symbols are used for safety notes.



#### **⚠ DANGER**

**Dangers for persons!**

Non-observance will inevitably cause irreversible injury or death.



#### **⚠ WARNING**

**Dangers for persons!**

Non-observance can lead to irreversible injury and even death.



#### **⚠ CAUTION**

**Dangers for persons!**

Non-observance can cause minor injuries.

#### **NOTICE**

**Material damage!**

Information about avoiding material damage.

### 1.1.2 Applicable documents

- General terms of business \*
- Catalog data sheet of the purchased product \*
- Assembly and operating manuals of the accessories \*

The documents labeled with an asterisk (\*) can be downloaded from [schunk.com/downloads](https://schunk.com/downloads).

### 1.1.3 Sizes

This operating manual applies to the following sizes:

- SFL 25
- SFL 40
- SFL 64

### 1.1.4 Variants

This operating manual applies to the following variations:

- SFL swivel angle 90°
- SFL swivel angle 180°
- SFL with elastomer damping
- SFL with shock absorbers

## 1.2 Warranty

If the product is used as intended, the warranty is valid for 24 months from the ex-works delivery date under the following conditions:

- Observe the ambient conditions and operating conditions, ▶ 2.5 [ 9]
- Observe the specified maintenance and lubrication intervals, ▶ 8 [ 35]

Parts touching the workpiece and wear parts are not included in the warranty.

A disassembly of the product that exceeds the instructions described in this manual leads to an expiration of the warranty.

### 1.3 Scope of delivery

The scope of delivery includes

- Vane Swivel Unit SFL in the version ordered
- Assembly and Operating Manual
- Accessory pack

#### 1.3.1 Accessory pack

Content of the accessory pack:

- Steel balls
- Centering sleeves
- O-rings
- Screws
- Cylindrical pins

Accessory pack for	ID number
SFL 25	5514440
SFL 40	5514441
SFL 64	5514442

### 1.4 Accessories

A wide range of accessories are available for this product

For information regarding which accessory articles can be used with the corresponding product variants, see catalog data sheet.

#### 1.4.1 Sealing kit

Seal kit for	ID number
SFL 25	5516255
SFL 40	5516256
SFL 64	5516257

contents of the sealing kit, ► 8.9 [43].

## 2 Basic safety notes

### 2.1 Intended use

The product may only be used for turning, swivelling and positioning workpieces or other automation components.

- The product may only be used within the scope of its technical data, ▶ 3 [15].
- When implementing and operating components in safety-related parts of the control systems, the basic safety principles in accordance with DIN EN ISO 13849-2 apply. The proven safety principles in accordance with DIN EN ISO 13849-2 also apply to categories 1, 2, 3 and 4.
- The product is intended for installation in a machine/ automated system. The applicable guidelines for the machine/ automated system must be observed and complied with.
- The product is intended for industrial and industry-oriented use.
- Appropriate use of the product includes compliance with all instructions in this manual.

### 2.2 Not intended use

It is not intended use if the product is used, for example, as a pressing tool, stamping tool, lifting gear, guide for tools, cutting tool, clamping device or a drilling tool.

- Any utilization that exceeds or differs from the appropriate use is regarded as misuse.

### 2.3 Constructional changes

#### Implementation of structural changes

Modifications, changes or reworking, e.g. additional threads, holes, or safety devices, can damage the product or impair its functionality or safety.

- Structural changes should only be made with the written approval of SCHUNK.

## 2.4 Spare parts

### Use of unauthorized spare parts

Using unauthorized spare parts can endanger personnel and damage the product or cause it to malfunction.

- Use only original spare parts or spares authorized by SCHUNK.

## 2.5 Ambient conditions and operating conditions

### Required ambient conditions and operating conditions

Incorrect ambient and operating conditions can make the product unsafe, leading to the risk of serious injuries, considerable material damage and/or a significant reduction to the product's life span.

- Make sure that the product is used only in the context of its defined application parameters, ▶ 3 [15].

## 2.6 Personnel qualification

### Inadequate qualifications of the personnel

If the personnel working with the product is not sufficiently qualified, the result may be serious injuries and significant property damage.

- All work may only be performed by qualified personnel.
- Before working with the product, the personnel must have read and understood the complete assembly and operating manual.
- Observe the national safety regulations and rules and general safety instructions.

The following personal qualifications are necessary for the various activities related to the product:

#### Trained electrician

Due to their technical training, knowledge and experience, trained electricians are able to work on electrical systems, recognize and avoid possible dangers and know the relevant standards and regulations.

#### Qualified personnel

Due to its technical training, knowledge and experience, qualified personnel is able to perform the delegated tasks, recognize and avoid possible dangers and knows the relevant standards and regulations.

#### Instructed person

Instructed persons were instructed by the operator about the delegated tasks and possible dangers due to improper behaviour.

#### Service personnel of the manufacturer

Due to its technical training, knowledge and experience, service personnel of the manufacturer is able to perform the delegated tasks and to recognize and avoid possible dangers.

## 2.7 Personal protective equipment

### Use of personal protective equipment

Personal protective equipment serves to protect staff against danger which may interfere with their health or safety at work.

- When working on and with the product, observe the occupational health and safety regulations and wear the required personal protective equipment.
- Observe the valid safety and accident prevention regulations.
- Wear protective gloves to guard against sharp edges and corners or rough surfaces.
- Wear heat-resistant protective gloves when handling hot surfaces.
- Wear protective gloves and safety goggles when handling hazardous substances.
- Wear close-fitting protective clothing and also wear long hair in a hairnet when dealing with moving components.

## 2.8 Notes on safe operation

### Incorrect handling of the personnel

Incorrect handling and assembly may impair the product's safety and cause serious injuries and considerable material damage.

- Avoid any manner of working that may interfere with the function and operational safety of the product.
- Use the product as intended.
- Observe the safety notes and assembly instructions.
- Do not expose the product to any corrosive media. This does not apply to products that are designed for special environments.
- Eliminate any malfunction immediately.
- Observe the care and maintenance instructions.
- Observe the current safety, accident prevention and environmental protection regulations regarding the product's application field.

## 2.9 Transport

### Handling during transport

Incorrect handling during transport may impair the product's safety and cause serious injuries and considerable material damage.

- When handling heavy weights, use lifting equipment to lift the product and transport it by appropriate means.

- Secure the product against falling during transportation and handling.
- Stand clear of suspended loads.

## 2.10 Malfunctions

### Behavior in case of malfunctions

- Immediately remove the product from operation and report the malfunction to the responsible departments/persons.
- Order appropriately trained personnel to rectify the malfunction.
- Do not recommission the product until the malfunction has been rectified.
- Test the product after a malfunction to establish whether it still functions properly and no increased risks have arisen.

## 2.11 Disposal

### Handling of disposal

The incorrect handling of disposal may impair the product's safety and cause serious injuries as well as considerable material and environmental harm.

- Follow local regulations on dispatching product components for recycling or proper disposal.

## 2.12 Fundamental dangers

### General

- Observe safety distances.
- Never deactivate safety devices.
- Before commissioning the product, take appropriate protective measures to secure the danger zone.
- Disconnect power sources before installation, modification, maintenance, or calibration. Ensure that no residual energy remains in the system.
- If the energy supply is connected, do not move any parts by hand.
- Do not reach into the open mechanism or movement area of the product during operation.

### 2.12.1 Protection during handling and assembly

#### Incorrect handling and assembly

Incorrect handling and assembly may impair the product's safety and cause serious injuries and considerable material damage.

- Have all work carried out by appropriately qualified personnel.
- For all work, secure the product against accidental operation.
- Observe the relevant accident prevention rules.
- Use suitable assembly and transport equipment and take precautions to prevent jamming and crushing.

#### **Incorrect lifting of loads**

Falling loads may cause serious injuries and even death.

- Stand clear of suspended loads and do not step into their swiveling range.
- Never move loads without supervision.
- Do not leave suspended loads unattended.

### **2.12.2 Protection during commissioning and operation**

#### **Falling or violently ejected components**

Falling and violently ejected components can cause serious injuries and even death.

- Take appropriate protective measures to secure the danger zone.
- Never step into the danger zone during operation.

### **2.12.3 Protection against dangerous movements**

#### **Unexpected movements**

Residual energy in the system may cause serious injuries while working with the product.

- Switch off the energy supply, ensure that no residual energy remains and secure against inadvertent reactivation.
- Never rely solely on the response of the monitoring function to avert danger. Until the installed monitors become effective, it must be assumed that the drive movement is faulty, with its action being dependent on the control unit and the current operating condition of the drive. Perform maintenance work, modifications, and attachments outside the danger zone defined by the movement range.
- To avoid accidents and/or material damage, human access to the movement range of the machine must be restricted. Limit/prevent accidental access for people in this area due through technical safety measures. The protective cover and protective fence must be rigid enough to withstand the maximum possible movement energy. EMERGENCY STOP switches must be easily and quickly accessible. Before starting up the machine

or automated system, check that the EMERGENCY STOP system is working. Prevent operation of the machine if this protective equipment does not function correctly.

#### **2.12.4 Protection against electric shock**

##### **Possible electrostatic energy**

Components or assembly groups may become electrostatically charged. When the electrostatic charge is touched, the discharge may trigger a shock reaction leading to injuries.

- The operator must ensure that all components and assembly groups are included in the local potential equalisation in accordance with the applicable regulations.
- While paying attention to the actual conditions of the working environment, the potential equalisation must be implemented by a specialist electrician according to the applicable regulations.
- The effectiveness of the potential equalisation must be verified by executing regular safety measurements.

## 2.13 Notes on particular risks



### **⚠ WARNING**

#### **Risk of injury due to unexpected movements!**

If the power supply is switched on or residual energy remains in the system, components can move unexpectedly and cause serious injuries.

- Before starting any work on the product: Switch off the power supply and secure against restarting.
- Make sure, that no residual energy remains in the system.



### **⚠ WARNING**

#### **Risk of injury from objects falling and being ejected!**

Falling and ejected objects during operation can lead to serious injury or death.

- Take appropriate protective measures to secure the danger zone.



### **⚠ WARNING**

#### **Risk of injury from rotating components!**

In the case of swivel units or rotary tables with a rotary drive, serious injuries can be caused by rotating components.

- Take appropriate protective measures to secure the danger zone.

### 3 Technical data

#### 3.1 Type key

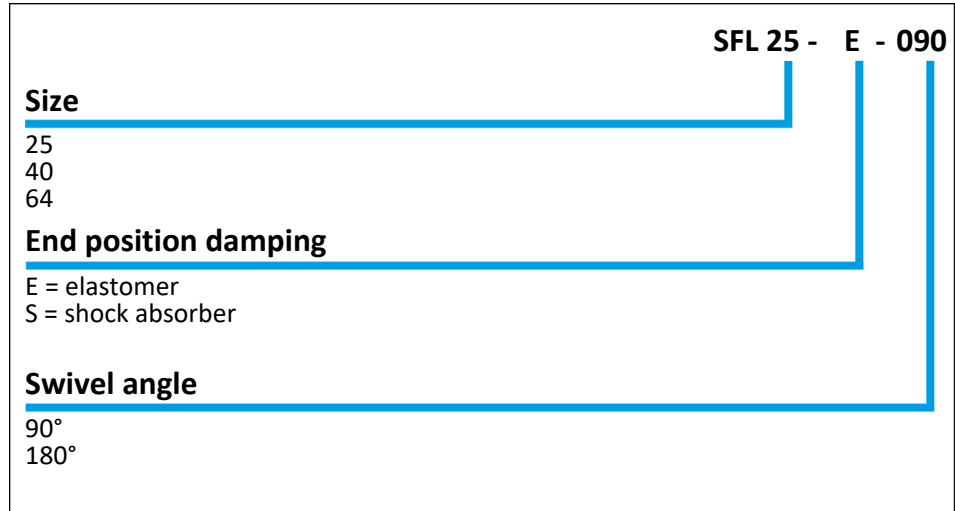

#### 3.2 Basic data

##### Connection data

Designation	SFL 25 E 90°	SFL 25 E 180°	SFL 40 E 90°	SFL 40 E 180°	SFL 64 E 90°	SFL 64 E 180°
Nominal working pressure [bar]			6			
Min. pressure [bar]	4		2.5		2	
Max. pressure [bar]	6.5		6.5		6.5	
Diameter connecting hose [mm]			3		6	
End position damping	Elastomer damping					

Designation	SFL 40 S 90°	SFL 40 S 180°	SFL 64 S 90°	SFL 64 S 180°
Nominal working pressure [bar]			6	
Min. pressure [bar]	3		2	
Max. pressure [bar]	6.5		6.5	
Diameter connecting hose [mm]	3		6	
End position damping	Hydraulic shock absorber			

More technical data is included in the catalog data sheet.  
Whichever is the latest version.

### Environmental and operating conditions

Designation	SFL 25	SFL 25	SFL 40	SFL 40	SFL 64	SFL 64
	E 90°	E 180°	E 90°	E 180°	E 90°	E 180°
Ambient temperature [°C]						
min.				-10		
max.				+90		
Protection class IP *				52		
Noise emission [dB(A)]				≤ 70		

Designation	SFL 40	SFL 40	SFL 64	SFL 64 S
	S 90°	S 180°	S 90°	180°
Ambient temperature [°C]				
min.			+5	
max.			+60	
Protection class IP *			52	
Noise emission [dB(A)]			≤ 70	

- \* For use in dirty ambient conditions (e.g. sprayed water, vapors, abrasion or processing dust) SCHUNK offers corresponding product options as standard. SCHUNK also offers customized solutions for special applications in dirty ambient conditions.

## 4 Design and description

### 4.1 Configuration

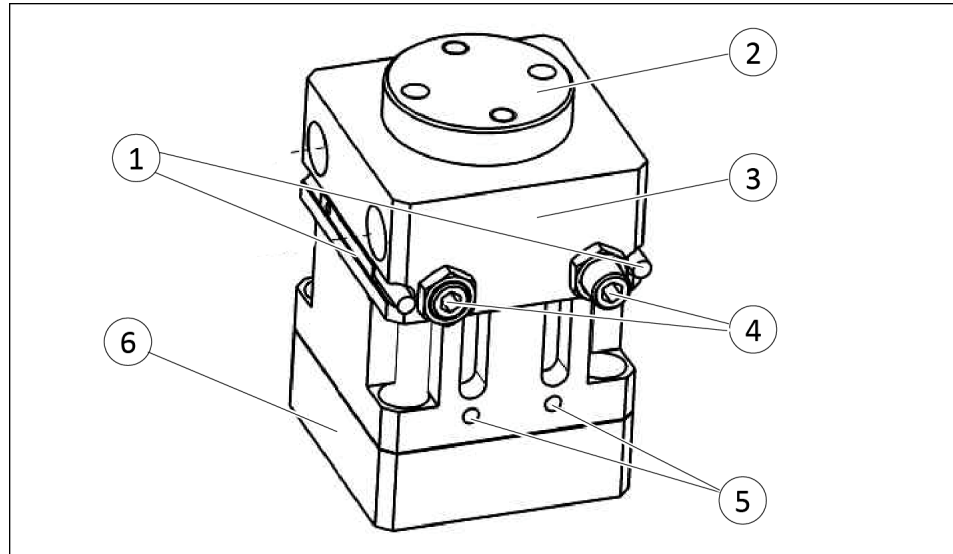

*Vane Swivel Unit SFL*

1	Sensors
2	Turntable for fastening the customer-specific attachment part
3	DKM feed-through compact module
4	End position damping via elastomer for E variant or shock absorber for S variant
5	Main compressed air connection
6	FAN rotor drive

### 4.2 Description

- The swivel wing – hereafter referred to as the swivel unit – is suitable for swivel tasks up to 180°.
- The swivel angle can be flexibly adjusted between 0° and 180°. The swivel angle end positions are roughly adjusted using balls. Adjustable end position dampers are used for fine adjustment.
- The speed can be regulated via external throttle reductions of the exhaust air.

## 5 Assembly

### 5.1 Assembling and connecting



#### **⚠ DANGER**

##### **Danger of explosion in potentially explosive areas!**

- Observe supplementary sheet for products with explosion-resistant versions "SFL -...-EX".



#### **⚠ WARNING**

##### **Risk of injury due to unexpected movements!**

If the power supply is switched on or residual energy remains in the system, components can move unexpectedly and cause serious injuries.

- Before starting any work on the product: Switch off the power supply and secure against restarting.
- Make sure, that no residual energy remains in the system.

#### **NOTICE**

##### **Material damage due to faulty settings and assembly.**

If the end position is approached too abruptly, the product may be damaged.

- Ensure the turning / swiveling movement is carried out without bouncing or bumping.
- Therefore provide sufficient throttling and damping.
- Please observe the information in the catalog data sheet.

#### **NOTE**

- Observe the requirements for the compressed air supply, ▶ 3 [15].
- In case of compressed air loss (cutting off the energy line), the components lose their dynamic effects and do not remain in a secure position. However, the use of a SDV-P pressure maintenance valve is recommended in this case in order to maintain the dynamic effect for some time. Product variants are also offered with mechanical gripping force via springs, which also ensure a minimum clamping force in the event of a pressure drop.

- 1.** Screw the swivel unit to the machine/system on the side or bottom, ▶ 5.2.1 [□ 20].
  - ⇒ If necessary, use suitable connecting elements, e.g., adapter plates. Design suggestion for the adapter plate, ▶ 5.2.3 [□ 23].
  - ⇒ Use the centering sleeves from the accessory pack to ensure safe transmission of transverse forces and positioning of the swivel unit.
  - ⇒ Observe the maximum tightening torque, permissible screw-in depth, and, if applicable, strength class.
- 2.** Attach the customer-specific attachment to the turntable with two screws and two cylindrical pins, ▶ 5.2.1 [□ 20].
  - ⇒ Observe the maximum tightening torque, permissible screw-in depth, and, if applicable, strength class.
- 3.** Only open the required air connections (main air connection or direct connection), ▶ 5.2.2 [□ 22].
- 4.** Connect the supply lines to the main air connections "A" and "B".
  - ⇒ Screw on the air connections.
- 5.** OR: Connect the swivel unit via the hose-free direct connection.
  - ⇒ Use the O-rings from the accessory pack.
  - ⇒ Close any main air connections that are not required using the sealing screws from the accessory pack.
- 6.** Check the opening and closing times, ▶ 6.1 [□ 27].
- 7.** Adjust the end positions, ▶ 6.2 [□ 27].
- 8.** Install the sensor, ▶ 5.3 [□ 25].

## 5.2 Connections

### 5.2.1 Mechanical connection

#### Connections at the housing

- The product can be mounted from four sides.
- When selecting the fastening screws, observe the values prescribed by SCHUNK (see table below).
- Suggestion for designing the adapter plate, ► 5.2.3 [ 23].

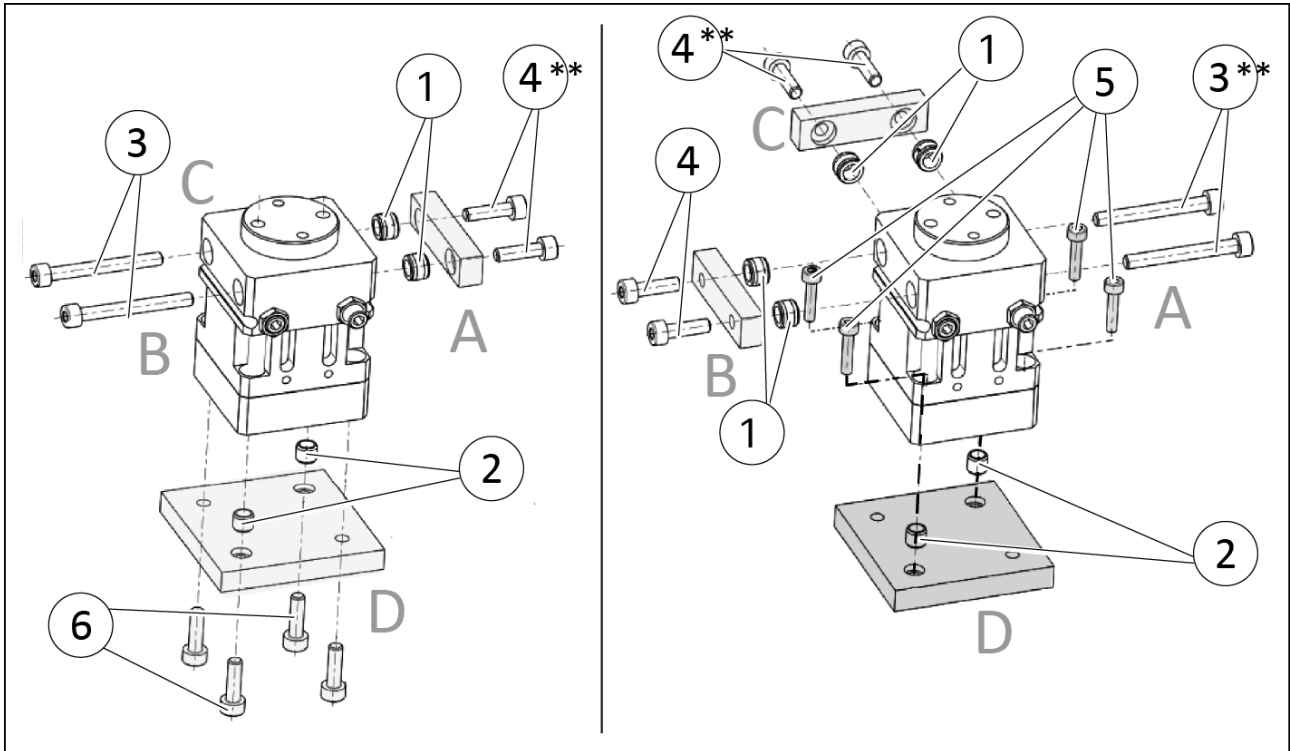

Possibilities for mounting the product to the housing

\*\* Use A2 screws from the accessory pack to ensure the function of the sensor.

Item	Mounting	25	40	64
<b>Side A, B, C - lateral mounting</b>				
1	Centering sleeve - diameter [mm]	Ø5	Ø8	Ø10
	Depth of the fit in the adapter plate [mm]	2	2.5	3
3	Screw	M2.5	M4	M5
	Screw according to standard	DIN EN ISO 4762 Max. strength class 8.8		
4 **	Screw	M3	M5	M6
	Maximum depth of engagement [mm]	12.2	19	25
	Screw according to standard	DIN EN ISO 4762 Max. strength class 8.8		
<b>Side D - mounting at bottom-side</b>				
2	Centering sleeve - diameter [mm]	Ø5	Ø8	Ø10
	Depth of the fit in the adapter plate [mm]	2	2.5	3
5 *	Screw	M2.5	M3	M5
	Screw according to standard	DIN EN ISO 4762 Max. strength class 8.8		
6 *	Screw	M3	M4	M6
	Maximum depth of engagement [mm]	8	8	11
	Screw according to standard	DIN EN ISO 4762 Max. strength class 8.8		

\* not included in scope of delivery

## NOTE

- When monitoring via magnetic switches, a minimum distance of 10 mm is to be observed between the units in the event of the assembly of several units next to each other.

## Connections at the turntable

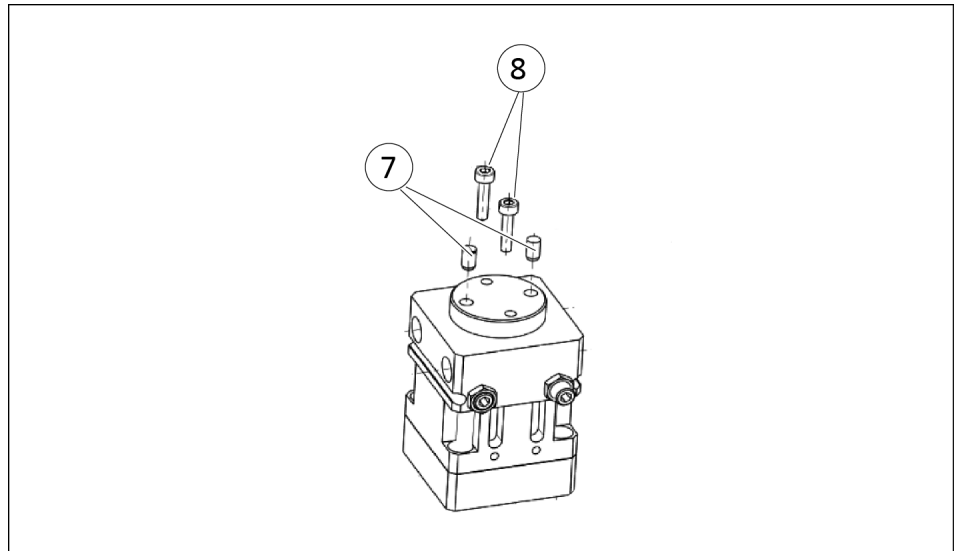

Mounting at the turntable

Item	Mounting	25	40	64
7	Cylindrical pin – diameter [mm]	Ø3	Ø4	Ø5
	Depth of the fit in the adapter plate [mm]	3	3	4
8 *	Screw	M3	M4	M6
	Maximum screw-in depth [mm]	4	6	8
	Screw according to standard	DIN EN ISO 4762 Max. strength class 8.8		

\* not included in scope of delivery

### 5.2.2 Pneumatic connection

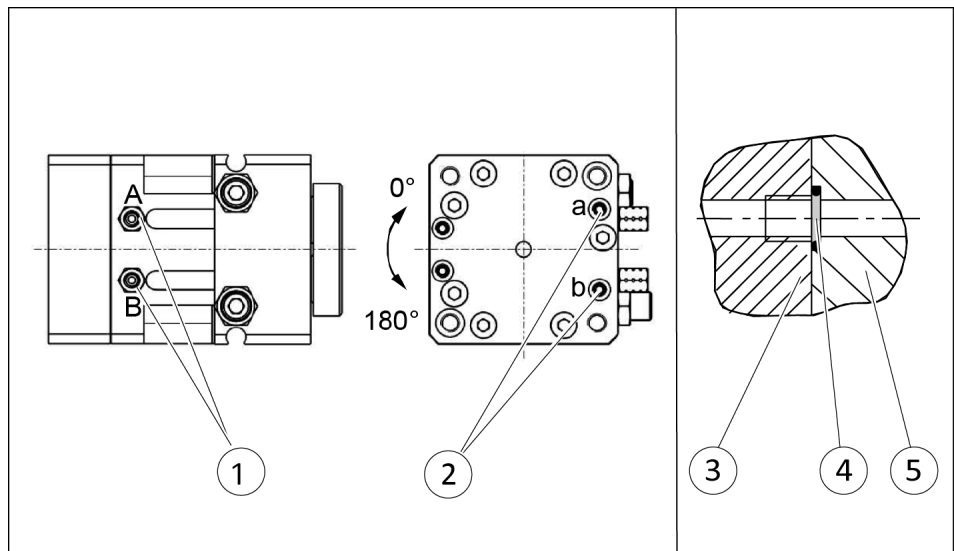

Compressed air connections

- 1 Main connections (Hose connection)  
A: swivel 0° – 180°, B: swivel 180° – 0°
- 2 Hose-free direct connection at the base  
a: swivel 0° – 180°, b: swivel 180° – 0°

Hose-free direct connection

3	Swivel unit	5	Adapter plate	
4	O-ring			
Item	Mounting	25	40	64
1	Thread in the main air connections	M3	M3	M5
	Maximum screw-in depth [mm]	3	4	4

**NOTE**

**Due to the design with a pneumatically driven swivel wing, a small amount of leakage may occur.**

Throttle reducers are installed in the main connections "A" and "B" upon delivery.

These must not be removed.

When using the direct connections "a" and "b," the sealing screws included in the accessory pack must be used for the corresponding main connections "A" and "B."

When using the direct connections "a" and "b," sufficient throttling must also be ensured, which should be adjusted by means of exhaust air throttling. For this purpose, the throttle reducers of the main connections, which are designed for a medium mounting load, can be removed there and mounted on the adapter plate, for example.

**5.2.3 Design suggestion for adapter plate**

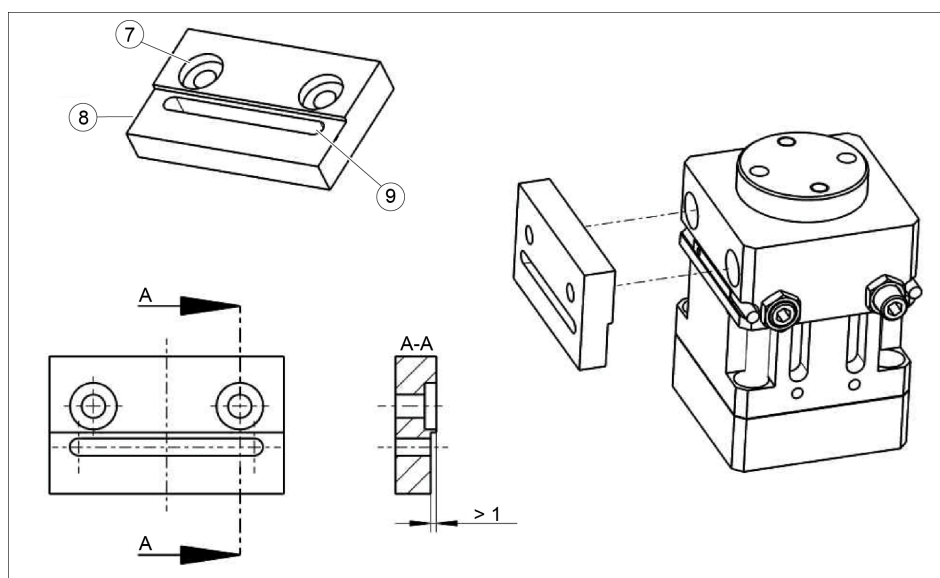

Adapter plate for lateral mounting of the SFL

Item	Mounting	25	40	64
7	Bore holes for the centering sleeves [mm]	5	8	10
	Depth of the bore holes [mm]	2	2.5	3
8 *	Min. recess depth [mm]	1	1	1
9 *	Groove length for adjusting the magnetic switch [mm]	18	30	40

\* When designing the adapter plates for the lateral mounting of the swivel unit, ensure that, in case of the sizes 25 and 40, the sensors can slightly protrude MMS 22 over the housing after the assembly. The adapter plates can be implemented as illustrated in the example. Observe the above points (8) and (9).

### NOTICE

**Ferromagnetic adapter plates have a strong influence on the process reliability of the magnetic switch monitoring.**

- For process-reliable monitoring, the adapter plates and the attachments in the closer surrounding of the swivel unit should be made of non-ferromagnetic material.

## 5.3 Mounting the sensor

### NOTE

Observe the assembly and operating manual of the sensor for mounting and connecting.

The product is prepared for the use of sensors.

- For the exact type designations of suitable sensors, please see catalog datasheet and ▶ 5.3.1 [📄 25].
- For technical data for the suitable sensors, see assembly and operating manual and catalog datasheet.
  - The assembly and operating manual and catalog datasheet are included in the scope of delivery for the sensors and are available at [schunk.com](https://www.schunk.com).
- Information on handling sensors is available at [schunk.com](https://www.schunk.com) or from SCHUNK contact persons.

### 5.3.1 Overview of sensors

Designation	SFL		
	25	40	64
Magnetic switch MMS 22	X	X	X

### 5.3.2 Assembling the magnetic switch MMS 22

### NOTE

The monitoring of the swiveling movement with sensors MMS 22 can only be implemented process reliably within the ranges of  $0^\circ \pm 3^\circ$  and  $180^\circ \pm 3^\circ$  or  $0^\circ \pm 3^\circ$  and  $90^\circ \pm 3^\circ$ .

Swivel angle adjustment and monitoring range, ▶ 6.2.1 [📄 27].

### NOTE

**Ferromagnetic material changes the switching positions of the sensor. For example: Adapter plate made of ordinary steel.**

At ferromagnetic adapter plates:

- First mount the product on the adapter plate.
- Then set the position of the magnetic switch.

### NOTICE

**Risk of damage to the sensor during assembly!**

- Observe the maximal tightening torque.

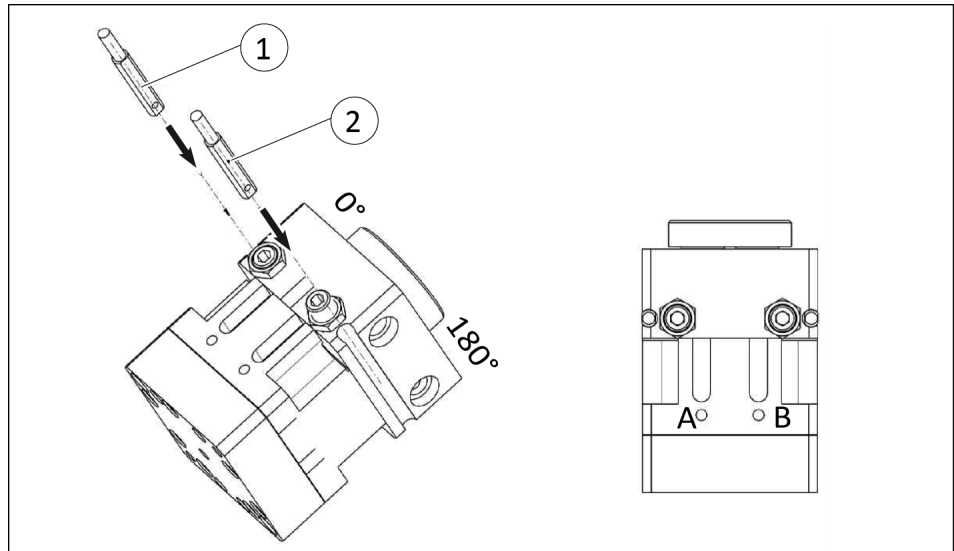

Magnetic switch assembly

Item	Functional description
1	End position monitoring, 0° position swiveling
2	End position monitoring, 90° or 180° position swiveling

1. Connect the sensor and fasten the cable, see the sensor's assembly and operating manual.
2. Pressurize connection B until the swivel unit has reached its end position (starting position 0°, ▶ 5.2.2 [22]).
3. Push the sensor (1) into the groove until the sensor switches and the LED lights up.
4. Fasten the sensor (1) in this position using a threaded pin. Tightening torque: 10 Ncm.
5. Swivel the unit repeatedly back and forth and check whether the sensor is losing the signal and receiving it again.
6. If the sensor (1) does not switch when reaching the end position, push the sensor (1) a little bit further into the groove until it switches again.
7. Check the switching position and, if necessary, repeat the above mentioned steps until the sensor switches securely when reaching the end position even after multiple swivel movements.
8. Vent connection B and pressurize connection A with compressed air until the swivel unit has reached the end position ▶ 5.2.2 [22]:
  - for 180° variant: end position 180°
  - for 90° variant: end position 90°.
9. Adjust the sensor (2).

## 6 Commissioning

### NOTICE

#### Material damage due to faulty settings and assembly.

If the end position is approached too abruptly, the product may be damaged.

- Ensure the turning / swiveling movement is carried out without bouncing or bumping.
- Therefore provide sufficient throttling and damping.
- Please observe the information in the catalog data sheet.

### 6.1 Checking opening and closing intervals

If the swivel unit does not achieve the opening and closing times specified in the current catalog, check the following points:

- Do the compressed air lines to the swivel unit have a sufficient internal diameter in relation to the compressed air consumption?
- Are the compressed air lines between the swivel unit and the valve as short as possible?
- Is the flow rate of the directional control valve sufficient for the compressed air consumption of the swivel unit?

If, despite optimal compressed air connections, the movement times determined by SCHUNK are not achieved in the application, SCHUNK recommends the use of quick exhaust valves directly on the swivel unit.

### 6.2 Adjusting the swivel angle

By inserting or removing balls in/from a ball guide rail, the range of the swivel angle can be roughly adjusted between 0° and 180° or 0° and 90°.

Adjust the end position dampers (shock absorbers for S-variant or elastomer for E-variant) in order to fine tune the end positions of the swivel angle range.

#### 6.2.1 Overview of the swivel angle range

Standard total swivel angle range	90 ° or 180°		
	Size 25	Size 40	Size 64
Minimum swivel angle range	Can be reduced down to 0° for any position within the total swivel angle range of the standard unit		
Angle limitation per ball [°]	32	19	13.5
Min. projection A [mm], E variants	4	3	4.5

Standard total swivel angle range	90 ° or 180°		
	Size 25	Size 40	Size 64
Max. projection B [mm], E variants	7	7	9.5
Min. projection A [mm], S variants	-	19.5	28
Max. projection B [mm], S variants	-	23.5	33

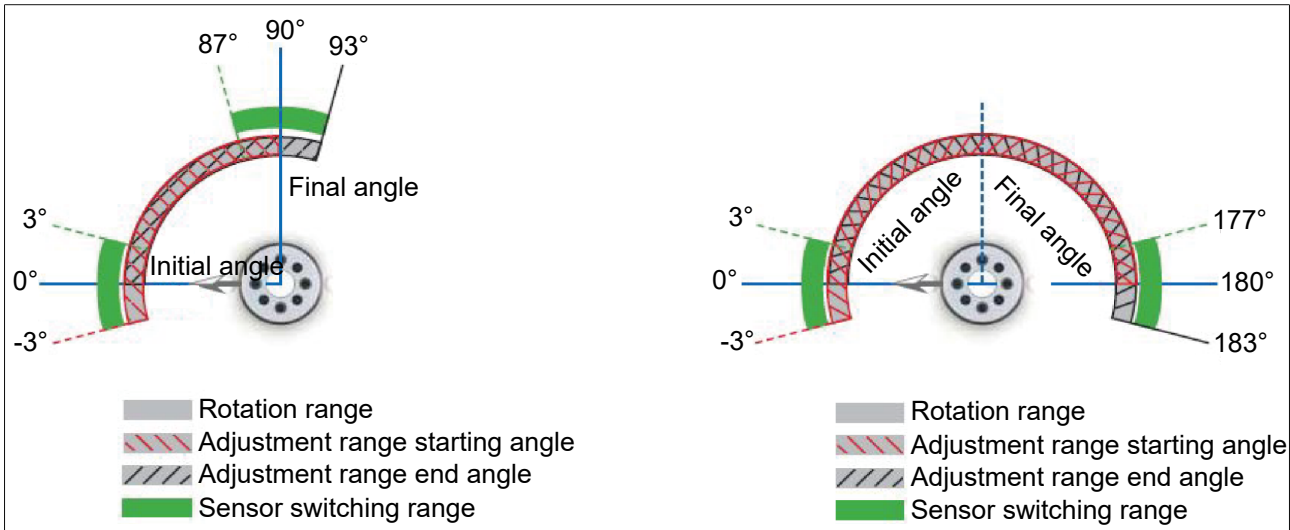

Swivel angle adjustment and monitoring range SFL

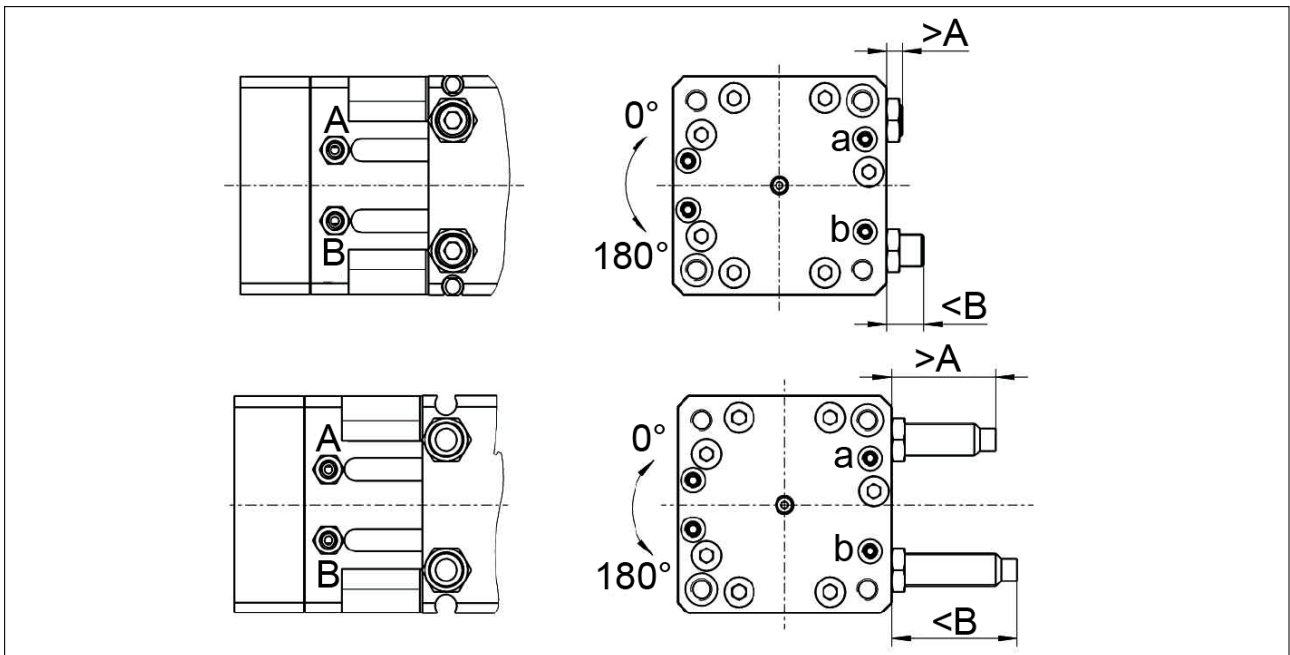

Total swivel angle range

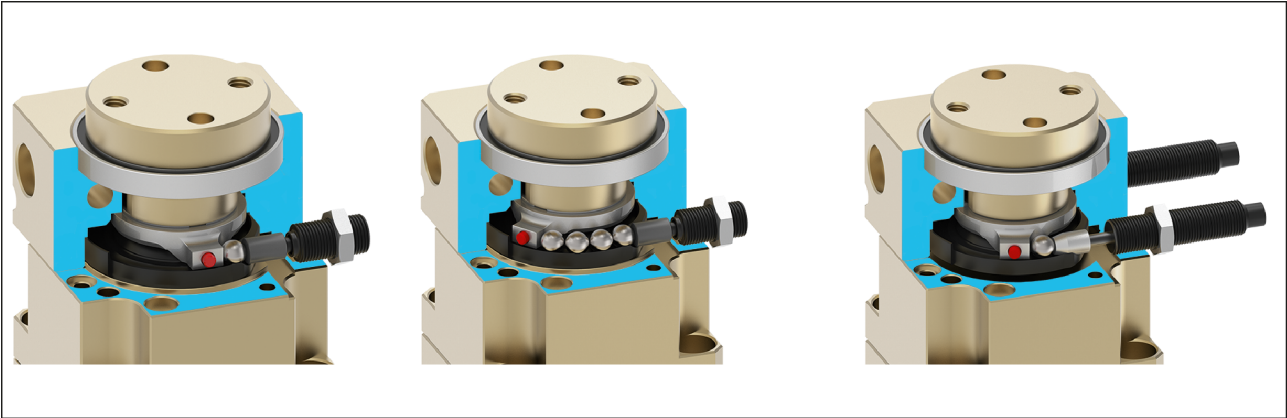

Stepless angular adjustment via balls

## 6.2.2 Adjusting the swivel angle for the E variant

### NOTICE

#### Material damage due to incorrect settings and assembly.

- Observe the minimal and maximal admissible projections of the end positions dampers (shock absorbers or elastomer).
- If a swivel angle is not reached by adjusting the end position dampers, insert or remove the steel balls in/from a ball guide rail. Ensure that there is at least one ball per damper side.

Position of the item numbers, ▶ 8.9 [43]

#### Rough adjustment

If a swivel angle **between** 0° and 180° or 0° and 90° is required, the number of steel balls (142) in the ball guide rail (85) must be adapted. The steel balls (142) are contained in the accessory pack, ▶ 1.3.1 [7].

1. Remove the stop (83), ▶ 8.6 [39].
2. Adapt the number of required steel balls, see "total swivel angle range" table, ▶ 6.2.1 [27].

#### Fine adjustment

1. Connect connections A and B to the compressed air supply.
2. Pressurize the connections A and B alternately with compressed air and swivel the swivel unit.
3. **Adjusting end position 1:** Pressurize connection B with compressed air.
  - ⇒ The swivel unit reaches the end position in counter-clockwise direction, ▶ 5.2.2 [22]. The end position in direction of the 0° position is reached.
4. Place the swivel unit on a measuring table with the air connections pointing to the top.

5. Loosen the lock nut (124) and turn the stop (83) as follows:
  - ⇒ Unscrew the stop to enlarge the swivel angle range. In doing so, observe the maximal projection measurement B.
  - ⇒ Screw-in the stop to decrease the swivel angle range. In doing so, observe the minimum projection measurement A.
  - ⇒ For projection measurements A and B, see "total swivel angle range", ▶ 6.2.1 [□ 27]
6. Pressurize the connections A and B alternately with compressed air and swivel the swivel unit.
7. Check the set swivel angle repeatedly. Repeat the steps until the desired position is reached securely even after repeated swiveling.
8. **Adjusting end position 2:** Repeat the above mentioned steps, pressurize, however, connection A with compressed air.

### 6.2.3 Adjusting the swivel angle for the S variant

#### NOTICE

#### Material damage due to incorrect settings and assembly.

- Observe the minimal and maximal admissible projections of the end positions dampers (shock absorbers or elastomer).
- If a swivel angle is not reached by adjusting the end position dampers, insert or remove the steel balls in/from a ball guide rail. Ensure that there is at least one ball per damper side.

Position of the item numbers, ▶ 8.9 [□ 43]

#### Rough adjustment

If a swivel angle **between** 0° and 180° or 0° and 90° is required, the number of steel balls (142) in the ball guide rail (85) must be adapted. The steel balls (142) are contained in the accessory pack, ▶ 1.3.1 [□ 7].

1. Remove shock absorbers (120), ▶ 8.6 [□ 39].
2. Adapt the number of required steel balls, see "total swivel angle range" table, ▶ 6.2.1 [□ 27].

#### Fine adjustment

1. Connect connections A and B to the compressed air supply.
2. Pressurize the connections A and B alternately with compressed air and swivel the swivel unit.

- 3. Adjusting end position 1:** Pressurize connection **B** with compressed air.
  - ⇒ The swivel unit reaches the end position in counter-clockwise direction, ▶ 5.2.2 [📄 22]. The end position in direction of the 0° position is reached.
- 4.** Place the swivel unit on a measuring table with the air connections pointing to the top.
- 5.** Loosen the nut of the shock absorbers (121) and turn the shock absorber (120) as follows:
  - ⇒ Unscrew the shock absorber to enlarge the swivel angle range. In doing so, observe the maximal projection measurement B.
  - ⇒ Screw in the shock absorber to decrease the swivel angle range. In doing so, observe the projection measurement A.
  - ⇒ For projection measurements A and B, see "total swivel angle range", ▶ 6.2.1 [📄 27]
- 6.** Pressurize the connections A and B alternately with compressed air and swivel the swivel unit.
- 7.** Check the set swivel angle repeatedly. Repeat the steps until the desired position is reached securely even after repeated swiveling.
- 8. Adjusting end position 2:** Repeat the above mentioned steps, pressurize, however, connection **A** with compressed air.

### 6.3 Restart after long standstill

During a longer standstill, no compressed air may be applied to the product.

If issues occur during the restart process, see ▶ 7.2 [📄 32]

## 7 Troubleshooting

### 7.1 Product does not achieve the opening and closing times

Possible cause	Corrective action
Compressed air lines are not installed optimally.	If present: Open the flow control couplings on the product to the maximum that the movement of the jaws occurs without bouncing and hitting.
	Check compressed air lines.
	Inner diameters of compressed air lines are of sufficient size in relation to compressed air consumption.
	Keep compressed air lines between the product and directional control valve as short as possible.
	Flow rate of valve is sufficiently large relative to the compressed air consumption.
	<b>NOTICE! The throttle reduction must not be removed, even if opening and closing times are not achieved.</b>
	If you still cannot achieve the open and close times in the latest catalog, we recommend the use of quick-air-vent-valves directly at the product.

### 7.2 Swivel movement is not executed immediately

Possible cause	Corrective action
Product was at a standstill for a long time.	<ul style="list-style-type: none"> <li>• Vent the piston chamber.</li> <li>• Swivel once to end and starting positions.</li> <li>• Depressurize the product.</li> <li>• Carry out several depressurized swivel movements.</li> <li>• <b>NOTICE! Do not spray Teflon spray or penetrating oil into the air connections!</b> This only leads to a short-term improvement, but the grease lubrication will be washed out as a result. If the product has already been treated with Teflon spray or penetrating oil, it should be serviced or completely relubricated.</li> </ul>

### 7.3 The product is not moving smoothly into the end positions

Possible cause	Corrective action
Shock absorber defective.	Check shock absorber, if necessary, replace it. ▶ 8 [ 35]
Defective elastomer.	Check elastomer, if necessary, replace it. ▶ 8 [ 35]

### 7.4 The product is not performing the full stroke

Possible cause	Corrective action
Dirt between stop and the swivel unit.	Clean and lubricate product. ▶ 8 [ 35]
End positions are adjusted incorrectly.	Adjust end position. ▶ 6.2 [ 27]
Pressure drops below minimum.	Check air supply. ▶ 5.2.2 [ 22]
Components have come loose e.g. due to overloading.	Send the product with a repair order to SCHUNK or disassemble the product.
Shock absorber defective.	Check shock absorber, if necessary, replace it. ▶ 8 [ 35]
Defective elastomer.	Check elastomer, if necessary, replace it. ▶ 8 [ 35]

### 7.5 The product is swivelling abruptly

Possible cause	Corrective action
Too little grease in the mechanical guiding areas.	Clean and lubricate product. ▶ 8 [ 35]
Compressed air lines blocked.	Check compressed air lines for damage

### 7.6 The product is not moving

Possible cause	Corrective action
Pressure drops below minimum.	Check air supply. ▶ 5.2.2 [ 22]
Compressed air lines switched.	Check compressed air lines.
Unused air connections open.	Close unused air connections. ▶ 5.2.2 [ 22]
Proximity switch defective or set incorrect.	Adjust sensor or if necessary change sensor. ▶ 5.3 [ 25]
Component part defective.	Replace component or send it to SCHUNK for repair. Have Schunk check the application.

## 7.7 Torque is diminishing

Possible cause	Corrective action
Compressed air can escape.	Check seals, if necessary, disassemble the product and replace seals. ▶ 8.6 [📄 39]
Too much grease in the mechanical movement space.	Clean and lubricate product. ▶ 8 [📄 35]
Pressure drops below minimum.	Check air supply. ▶ 5.2.2 [📄 22]

## 8 Maintenance

### 8.1 Notes

#### Original spare parts

Use only original spare parts of SCHUNK when replacing spare and wear parts.

### 8.2 Maintenance interval

#### NOTICE

#### Material damage due to hardening lubricants!

Lubricants harden more quickly at temperatures above 60°C, leading to possible product damage.

- Reduce the lubricant intervals accordingly.

Interval (million cycles) for SFL 25 – 64	Maintenance work
2	Clean all parts thoroughly, check for damage and wear, if necessary replace seals and wearing parts, ▶ 8.6 [ 39].
2	Treat all grease areas with lubricant, ▶ 8.3 [ 36].
2	For S variant: Check that the shock absorber is working, if necessary replace the shock absorber, ▶ 8.4 [ 37].
2	For E variant: Check that the elastomer is working, if necessary replace the elastomer, ▶ 8.5 [ 38].

### 8.3 Lubricants/Lubrication points (basic lubrication)

During maintenance, treat all greased areas with lubricant. Thinly apply lubricant with a lint-free cloth.

SCHUNK recommends the lubricants listed.

Lubricant point	Lubricant
Ball guideSFL 25/40/64	SCHUNK grease 9
Metallic sliding surfaces	SCHUNK grease 9
Seals and sealing surfaces	SCHUNK grease 9
Rolling bearing	SCHUNK grease 10

\* non-food-compliant lubricant

Details regarding SCHUNK lubricant designations are available at [schunk.com/lubricants](http://schunk.com/lubricants).

The product contains food-compliant lubricants as standard. Components such as rolling bearings, linear guides, or shock absorbers are not provided with food-compliant lubricants.

**The requirements of standard EN 1672-2:2020 are not fully met.**

---

#### NOTE

- Change contaminated food-compliant lubricant.
  - Observe information in the safety data sheet from the lubricant manufacturer.
-

## 8.4 Replacing an elastomer for E variants

Position of the item numbers, ▶ 8.9 [43]

The elastomers have a limited lifespan depending on the load. For this reason, their function should be checked regularly. The elastomer is working correctly if the unit moves gently to the end positions.

The complete elastomer unit – consisting of stop, needle role, nut and damping bolt – can be ordered at SCHUNK.

1. Remove compressed air lines.
2. Loosen nuts (124).
3. Remove stops (83).
4. Remove needle roles (122). If the needle roles can't be removed, a little rod magnet or turning the swivel unit by hand may be helpful.
5. Assemble the new elastomer unit in reverse order.
6. Adjust the end positions, ▶ 6.2 [27].

## 8.5 Replacing a shock absorber for S variants

Position of the item numbers, ▶ 8.9 [ 43]

The shock absorbers have a limited lifespan, depending on the load. For this reason, their function should be checked regularly. The elastomer is working correctly if the unit moves gently to the end positions.

The complete shock absorber unit – consisting of shock absorber, sleeve and nut – can be ordered at SCHUNK. When replacing it, pay attention to the control number "-346" at the end of the damper designation.

1. Remove compressed air lines.
2. Loosen lock nut (121).
3. Remove shock absorber (120).
4. Remove sleeves (122). If the sleeves can't be removed, a little rod magnet or turning the swivel unit by hand may be helpful.
5. Assemble the new shock absorbers in reverse order.
6. Adjust the end positions, ▶ 6.2 [ 27].

## 8.6 Disassembling the swivel unit

Position of the item numbers, ▶ 8.9 [ 43]

### Disassembling the swivel unit into the basic modules DKM and FAN

1. Remove compressed air lines.
2. Turn the bushing (44) into center position.
3. Unscrew the screws (104).
4. Pull the DKM feed-through compact module (40) off the FAN rotor drive (50).

### Disassembling the DKM basic module

- The swivel unit has been disassembled into the basic modules DKM and FAN

---

### NOTE

If the housing (11), ball bearing (82) or bushing (44) is replaced, a new set of fitting discs (111/112) must be installed. This set is available at SCHUNK.

---

1. Remove the centering sleeves (108/109) from the housing (11).
2. **NOTICE! The balls (142) are lying loosely in the ball guide rail (85) and may fall out.** Remove the ball guide rail from the housing (11).
3. Remove the balls (142).
4. Unscrew the screws (140) and pull the stop (81) and the fitting disc set (111/112) off the bushing (44).
5. Pull the bushing (44) out of the housing (11).

### For the E variant continue as follows:

1. Loosen nuts (124).
2. Remove stops (83).
3. Remove needle roles (122).

### For S variant continue as follows:

1. Loosen nuts (124).
2. Remove shock absorbers (120).
3. Remove sleeves (122).

### Disassembling the FAN rotor drive

- The swivel unit has been disassembled into the basic modules DKM and FAN.
1. Unscrew the screws (101).

- 2.** Take the upper housing (51) from the lower housing (52).
- 3.** Remove O-rings (131) and centering sleeve.
- 4.** Take the rotor (53) out of the housing (52) and pull the bearing (130) off the rotor.
- 5.** Pull O-rings (132) off the rotor.
- 6.** Remove the stop rotor (58).
- 7.** Remove the stop sealing (59) and pull off the stop rotor.

## 8.7 Assembling the swivel unit

Position of the item numbers, ▶ 8.9 [ 43]

### NOTICE

#### Material damage due to incorrect assembly.

- Unless otherwise specified, secure all screws and nuts with Loctite no. 243.
- Observe tightening torques, ▶ 8.8 [ 43].

#### Assembling the DKM basic module

1. Grease the DKM housing (11) and the bushing (44) on the running surfaces and bearing points.
2. Grease the ball bearing (82).
3. Insert the ball bearing (82) into the housing (11).
4. Insert the bushing (44) into the housing (11).
5. Adjust the axial bearing seat of the bushing with the fitting discs (111/112).
6. Set stop (81) onto the bushing (44) and fasten it to the bushing using the screws (140).
7. Grease the ball guide (85).
8. Turn the bushing (44) that the stop (81) points in the opposite direction to the assembly bore holes of the stops (83) or shock absorbers (120).

#### For the E variant continue as follows:

1. Grease the needle rollers (122) and insert them into the fitting bores.
2. Insert respectively one ball (142) into the housing (11) in front of the needle roller (122).
3. Screw the stop (83) into the housing (11).
4. Mount the locking nut (124).

#### For S variant continue as follows:

1. Insert respectively one ball (142) into the housing (11).
2. Grease the sleeves (122) and put them onto the shock absorbers (120).
3. Insert the sleeves (122) into the fitting bores.
4. Screw the shock absorbers (120) into the housing (11).
5. Mount the nut (121).

### **Mounting the FAN rotor drive**

- 1.** Lubricate the upper (51) and lower housing (52) from the inside.
- 2.** Grease the entire stop rotor (58).
- 3.** Pull the stop seal (59) onto the stop rotor (58) and grease the two parts completely one more time.
- 4.** Insert the stop rotor (58) into the recess of the upper housing (51).
- 5.** Grease the entire rotor (53) except for the rectangular section.
- 6.** Pull both O-rings (132) onto the rotor (53) and grease the O-rings.
- 7.** Put the ball bearings (130) on the rotor (53).
- 8.** Put the rotor (53) in the upper housing (51) with the rectangular section facing downwards and turn it into the correct position:
  - for 090 variant: 90° towards the stop rotor (58)
  - for 180 variant: 180° towards the stop rotor (58)
- 9.** Insert the centering sleeve (108) into the upper housing (51).
- 10.** Grease the four O-rings (131) and place them in the machined faces provided for this purpose in the lower housing (52).
- 11.** Screw the upper housing (51) and the lower housing (52) together. Tighten the screws (101) crosswise.
- 12.** Insert the centering sleeves (108/109) and the cylindrical pins (141) into the upper housing (51).

### **Assembling the basic modules GKM and FAN**

- 1.** Turn the rectangular section of the rotor (53) with the longer side towards the center of the air connections A and B.
- 2.** Position the stop (81) with the magnets (141):
  - for 090 variant: One magnet points towards the 90° position and the other one towards the 180° position.
  - for 180 variant: One magnet points towards the 0° position and the other one towards the 180° position.
- 3.** Put the GKM basic module onto the FAN rotor drive and tighten it using the screws (104).
- 4.** Connect the compressed air connections.

## 8.8 Screw and nut tightening torques

Position of the item numbers, ▶ 8.9 [ 43]

Designation	Tightening torque [Nm]		
	SFL 25	SFL 40	SFL 64
Item 101	0.7	1.2	3.1
Item 104	0.7	1.2	3.1
Item 140	0.3	1.2	4
Item 121	0.8	1.3	3.1
Item 124	0.8	1.3	3.1

## 8.9 Assembly drawings

### 8.9.1 Assembly drawing of the basic modules

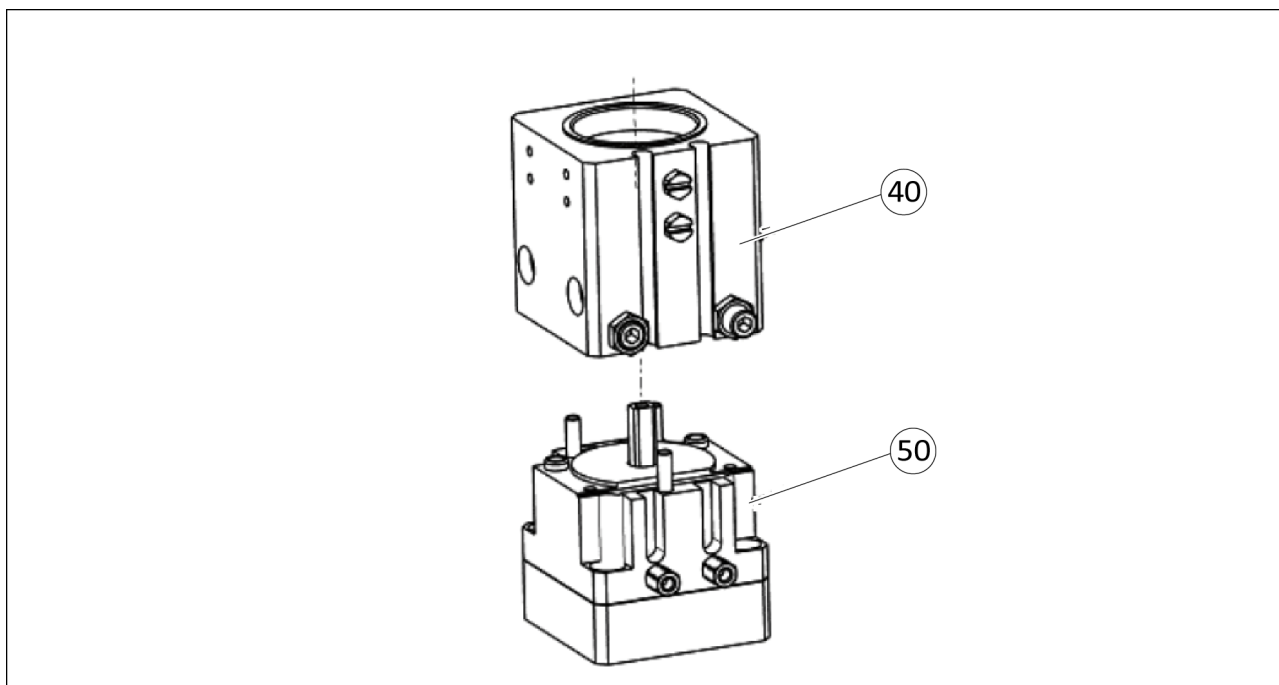

Basic module overview

40	DKM SFL feed-through compact module
50	FAN rotor drive

### 8.9.2 SFL assembly drawing

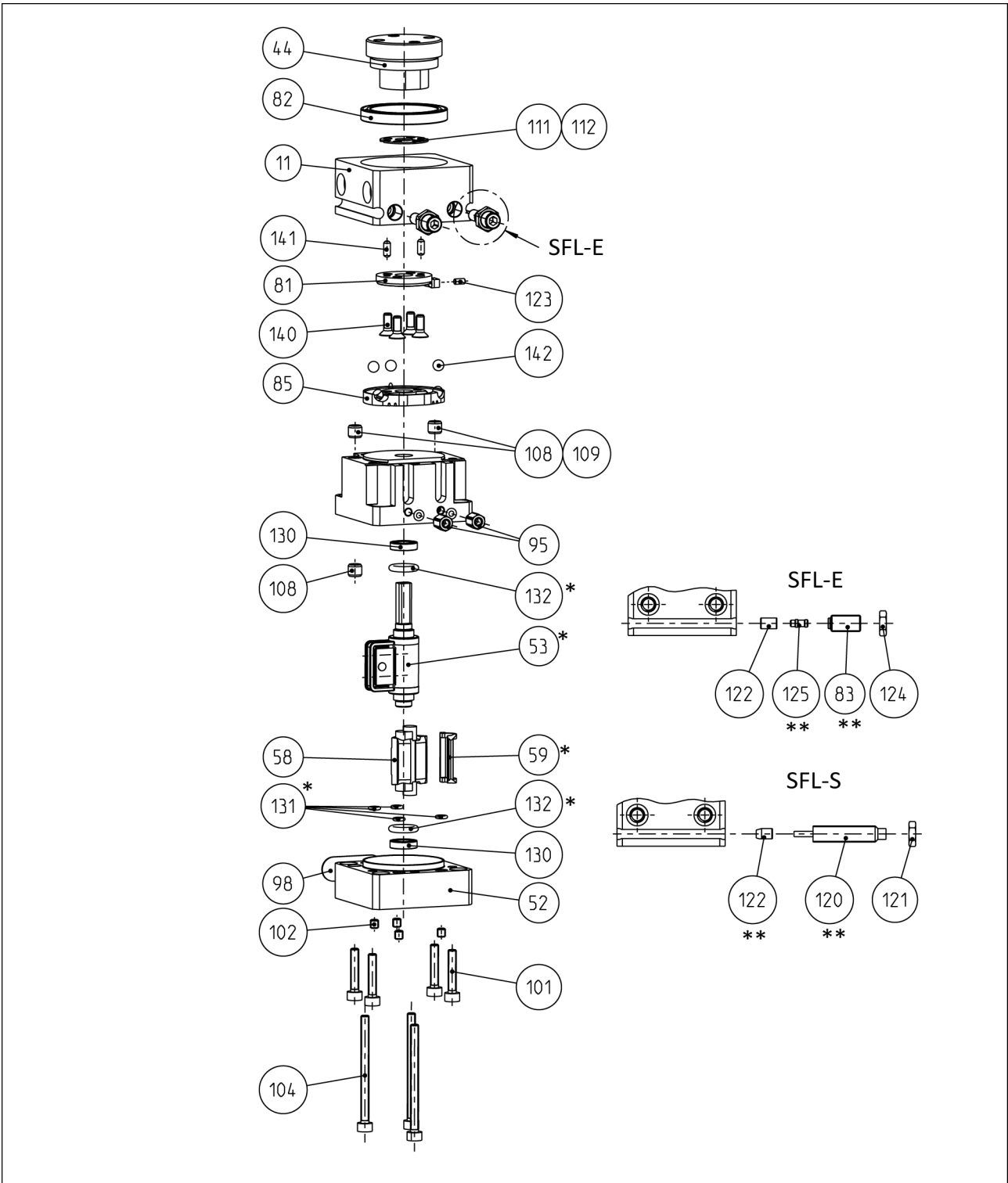

- \* Wearing part, included in sealing kit
- \*\* Wearing part, not included in sealing kit

## 9 Translation of the original declaration of incorporation

in terms of the Directive 2006/42/EG, Annex II, Part 1 Section B.

Manufacturer/  
Distributor                      SCHUNK SE & Co. KG  
Spanntechnik | Greiftechnik | Automatisierungstechnik  
Bahnhofstr. 106 – 134  
D-74348 Lauffen/Neckar

We hereby declare that the partly completed machine described below

Product designation:        Vane Swivel Unit / SFL /pneumatic  
ID number                      0304060, 0304064, 0304065, 0304068, 0304069,  
0304560,0304564, 0304565, 0304568, 0304569

meets the following basic occupational health and safety of the Machinery Directive 2006/42/EC:

No. 1.1.1, No. 1.1.2, No. 1.1.3, No. 1.1.5, No. 1.3.2, No. 1.5.3, No. 1.5.4, No. 1.5.6, No. 1.5.8, No. 1.5.10, No. 1.5.11, No. 1.5.13

The partly completed machinery may not be put into operation until it has been confirmed that the machine into which the partly completed machinery is to be installed complies with the provisions of the Machinery Directive (2006/42/EC). The declaration shall be rendered invalid if modifications are made to the product.

Applied harmonized standards, especially:

EN ISO 12100:2010              Safety of machinery – General principles for design –  
Risk assessment and risk reduction

The special technical documentation according to Annex VII, Part B, belonging to the partly completed machine, has been created.

Person authorized to compile the technical documentation:  
Stefanie Walter, Address: see manufacturer's address

*Signature: see original declaration*

Lauffen/Neckar, February 2026

Dr.-Ing. Manuel Baumeister,  
Head of Systems Engineering,  
Technology & Innovation



## 11 Information on the RoHS Directive, REACH Regulation and Substances of Very High Concern (SVHC)

### RoHS Directive

SCHUNK products are classified as "large-scale stationary installations" or as "large-scale stationary industrial tools" within the meaning of Directive 2011/65/EU and its extension 2015/863/EU "on the restriction of the use of certain hazardous substances in electrical and electronic equipment (RoHS)", or fulfill their intended function only as part of one. Therefore products from SCHUNK do not fall within the scope of the directive at this time.

### REACH Regulation

Products from SCHUNK fully comply with the regulations of Regulation (EC) No. 1907/2006 "concerning the Registration, Evaluation, Authorization and Restriction of Chemicals (REACH)" and its amendment 2022/477. SCHUNK attaches great importance to completely avoiding chemicals of concern to humans and the environment wherever possible.

Only in rare exceptional cases do SCHUNK products contain SVHC substances on the candidate list with a mass content above 0.1%. In accordance with Article. 33 (1) of Regulation (EC) No. 1907/2006, SCHUNK complies with its duty to "communicate information on substances in articles" and lists the components concerned and the substances used in an overview that can be viewed at [schunk.com/SVHC](https://schunk.com/SVHC).

*Signature: see original declaration*

Lauffen/Neckar, February 2026

Dr.-Ing. Manuel Baumeister,  
Head of Systems Engineering,  
Technology & Innovation



**SCHUNK SE & Co. KG**  
Spanntechnik | Greiftechnik | Automatisierungstechnik

Bahnhofstr. 106 - 134  
D-74348 Lauffen/Neckar  
Tel. +49-7133-103-0  
info@de.schunk.com  
schunk.com

Folgen Sie uns | *Follow us*



Wir drucken nachhaltig | *We print sustainable*