



Assembly and Operating Manual

SRU

Pneumatic Rotary Unit

Translation of the original manual

Hand in hand for tomorrow

Imprint

Copyright:

This manual is protected by copyright. The author is SCHUNK SE & Co. KG.
All rights reserved.

Technical changes:

We reserve the right to make alterations for the purpose of technical improvement.

Document number: 389439

Version: 15.00 | 16/12/2025 | en

Dear Customer,

Thank you for trusting our products and our family-owned company, the leading technology supplier of robots and production machines.

Our team is always available to answer any questions on this product and other solutions. Ask us questions and challenge us. We will find a solution!

Best regards,

Your SCHUNK team

Customer Management

Tel. +49-7133-103-2503

Fax +49-7133-103-2189

cmg@de.schunk.com



Please read the operating manual in full and keep it close to the product.

Table of Contents

1	General	5
1.1	About this manual.....	5
1.1.1	Presentation of Warning Labels	5
1.1.2	Applicable documents	6
1.1.3	Sizes.....	6
1.1.4	Variants	6
1.2	Warranty	6
1.3	Scope of delivery.....	6
1.3.1	Accessory pack.....	7
1.4	Accessories	7
1.4.1	Seal kit	7
2	Basic safety notes	8
2.1	Intended use.....	8
2.2	Not intended use	8
2.3	Constructional changes.....	8
2.4	Spare parts	8
2.5	Environmental and operating conditions.....	8
2.6	Personnel qualification	9
2.7	Personal protective equipment	9
2.8	Notes on safe operation.....	10
2.9	Transport.....	11
2.10	Malfunctions.....	11
2.11	Disposal	11
2.12	Fundamental dangers	11
2.12.1	Protection during handling and assembly	12
2.12.2	Protection during commissioning and operation	12
2.12.3	Protection against dangerous movements	12
2.12.4	Protection against electric shock.....	13
2.13	Notes on particular risks	14
3	Technical data	16
3.1	Type key.....	16
3.2	Basic data	16
4	Design and description	18
4.1	Design	18
4.2	Description	18

5 Assembly	19
5.1 Assembling and connecting.....	19
5.2 Connections	20
5.2.1 Mechanical connection.....	20
5.2.2 Pneumatic connection.....	22
5.3 Settings.....	23
5.3.1 Adjustment of the end positions.....	23
5.3.2 Adjustment of the central position (Variant M).....	24
5.4 Installing the sensors	25
5.4.1 Overview of sensors	25
5.4.2 Mounting MMS 22 magnetic switch	26
5.4.3 Mounting MMS 22-PI1 programmable magnetic switch.....	27
6 Commissioning	28
6.1 Setting the speed	28
6.2 Adjustment of the shock absorber stroke	30
6.2.1 Shock absorber stroke (variant H)	31
6.2.2 Shock absorber stroke (variant S)	32
7 Troubleshooting	33
7.1 Product does not move.....	33
7.2 Product does not travel through the entire stroke	33
7.3 Product rotates jerkily	33
7.4 Torque diminishes?.....	34
8 Maintenance	35
8.1 Notes.....	35
8.2 Maintenance interval	35
8.3 Lubricants/Lubrication points (basic lubrication)	36
8.4 Disassembly and assembly	37
8.4.1 Dismantle product.....	37
8.4.2 Notes for assembly	37
8.4.3 Tightening torque for screws	38
8.4.4 Assembly drawing	38
9 Translation of the original declaration of incorporation	42
10 UKCA declaration of incorporation	43
11 Information on the RoHS Directive, REACH Regulation and Substances of Very High Concern (SVHC)	44

1 General

1.1 About this manual

This manual contains important information for a safe and appropriate use of the product.

This manual is an integral part of the product and must be kept accessible for the personnel at all times.

Before starting work, the personnel must have read and understood this operating manual. Prerequisite for safe working is the observance of all safety instructions in this manual.

In addition to these instructions, the documents listed under ▶ 1.1.2 [6] are applicable.

NOTE: The illustrations in this manual are intended to provide a basic understanding and may deviate from the actual version.

1.1.1 Presentation of Warning Labels

To make risks clear, the following signal words and symbols are used for safety notes.



⚠ DANGER

Dangers for persons!

Non-observance will inevitably cause irreversible injury or death.



⚠ WARNING

Dangers for persons!

Non-observance can lead to irreversible injury and even death.



⚠ CAUTION

Dangers for persons!

Non-observance can cause minor injuries.

NOTICE

Material damage!

Information about avoiding material damage.

1.1.2 Applicable documents

- General terms of business *
- Catalog data sheet of the purchased product *
- Assembly and operating manuals of the accessories *
- For ATEX versions: Supplementary sheet "Installation and operating instructions - EX" *

The documents labeled with an asterisk (*) can be downloaded from schunk.com/downloads.

1.1.3 Sizes

This operating manual applies to the following sizes:

- SRU 8
- SRU 10
- SRU 12
- SRU 14

1.1.4 Variants

This operating manual applies to the following variations:

- SRU with elastomer dampening (S)
- SRU with hydraulic dampening (H)
- SRU without dampening (W)
- SRU With pneumatic center positioning (M)
- SRU With fluid feed-through
- SRU explosion-protected version (Ex)

1.2 Warranty

If the product is used as intended, the warranty is valid for 24 months from the ex-works delivery date under the following conditions:

- Observe the specified maintenance and lubrication intervals
- Observe the ambient conditions and operating conditions

Parts touching the workpiece and wear parts are not included in the warranty.

1.3 Scope of delivery

The scope of delivery includes

- Pneumatic Rotary Unit SRU in the version ordered
- Assembly and Operating Manual
- Accessory pack

1.3.1 Accessory pack

Content of the accessory pack:

- 2 x centering sleeves for mounting
- 2 x O-rings for hose-free direct connection
- 2 x locking screws for hose connections
- 2 x cylinder pin

Accessory pack for	Variants	ID number
SRU 8 SRU 10	W/H/S	1004955
	W/H/S-2	1004956
	W/H/S-M	1004957
	W/H/S-M-2	1004958
SRU 12		5524552
SRU 12 SRU 14	W/H/S	1004959
	W/H/S-4	1004960
	W/H/S-M	1004961
	W/H/S-M-4	1004962

Tab.: ID.-No. of the accessory pack

1.4 Accessories

A wide range of accessories are available for this product

For information regarding which accessory articles can be used with the corresponding product variants, see catalog data sheet.

1.4.1 Seal kit

Seal kit for	Variants	ID number
SRU 8 SRU 10	W/H/S	5517914
	W/H/S-M	5517915
	W/H/S-2/4	5517916
	W/H/S-2/4	5517917
SRU 12	W/H/S	5517918
	W/H/S-M	5517919
	W/H/S-2/4	5517920
	W/H/S-2/4	5517921
SRU 14	W/H/S	5517922
	W/H/S-M	5517923
	W/H/S-2/4	5517924
	W/H/S-2/4	5517925

Tab.: ID.-No. of the seal kit

contents of the sealing kit, ► 8.4.4 [38].

2 Basic safety notes

2.1 Intended use

The product may only be used for swiveling permissible attachment parts or workpieces.

- The product may only be used within the scope of its technical data, ▶ 3 [16].
- When implementing and operating components in safety-related parts of the control systems, the basic safety principles in accordance with DIN EN ISO 13849-2 apply. The proven safety principles in accordance with DIN EN ISO 13849-2 also apply to categories 1, 2, 3 and 4.
- The product is intended for installation in a machine/ automated system. The applicable guidelines for the machine/ automated system must be observed and complied with.
- The product is intended for industrial and industry-oriented use.
- Appropriate use of the product includes compliance with all instructions in this manual.

2.2 Not intended use

Inappropriate use includes using the product as a cutting tool or drilling tool, for example.

- Any utilization that exceeds or differs from the appropriate use is regarded as misuse.

2.3 Constructional changes

Implementation of structural changes

Modifications, changes or reworking, e.g. additional threads, holes, or safety devices, can damage the product or impair its functionality or safety.

- Structural changes should only be made with the written approval of SCHUNK.

2.4 Spare parts

Use of unauthorized spare parts

Using unauthorized spare parts can endanger personnel and damage the product or cause it to malfunction.

- Use only original spare parts or spares authorized by SCHUNK.

2.5 Environmental and operating conditions

Required ambient conditions and operating conditions

Incorrect ambient and operating conditions can make the product unsafe, leading to the risk of serious injuries, considerable material damage and/or a significant reduction to the product's life span.

2.6 Personnel qualification

Inadequate qualifications of the personnel

If the personnel working with the product is not sufficiently qualified, the result may be serious injuries and significant property damage.

- All work may only be performed by qualified personnel.
- Before working with the product, the personnel must have read and understood the complete assembly and operating manual.
- Observe the national safety regulations and rules and general safety instructions.

The following personal qualifications are necessary for the various activities related to the product:

Trained electrician

Due to their technical training, knowledge and experience, trained electricians are able to work on electrical systems, recognize and avoid possible dangers and know the relevant standards and regulations.

Qualified personnel

Due to its technical training, knowledge and experience, qualified personnel is able to perform the delegated tasks, recognize and avoid possible dangers and knows the relevant standards and regulations.

Instructed person

Instructed persons were instructed by the operator about the delegated tasks and possible dangers due to improper behaviour.

Service personnel of the manufacturer

Due to its technical training, knowledge and experience, service personnel of the manufacturer is able to perform the delegated tasks and to recognize and avoid possible dangers.

2.7 Personal protective equipment

Use of personal protective equipment

Personal protective equipment serves to protect staff against danger which may interfere with their health or safety at work.

- When working on and with the product, observe the occupational health and safety regulations and wear the required personal protective equipment.
- Observe the valid safety and accident prevention regulations.

- Wear protective gloves to guard against sharp edges and corners or rough surfaces.
- Wear heat-resistant protective gloves when handling hot surfaces.
- Wear protective gloves and safety goggles when handling hazardous substances.
- Wear close-fitting protective clothing and also wear long hair in a hairnet when dealing with moving components.

2.8 Notes on safe operation

Incorrect handling of the personnel

Incorrect handling and assembly may impair the product's safety and cause serious injuries and considerable material damage.

- Avoid any manner of working that may interfere with the function and operational safety of the product.
- Use the product as intended.
- Observe the safety notes and assembly instructions.
- Do not expose the product to any corrosive media. This does not apply to products that are designed for special environments.
- Eliminate any malfunction immediately.
- Observe the care and maintenance instructions.
- Observe the current safety, accident prevention and environmental protection regulations regarding the product's application field.

2.9 Transport

Handling during transport

Incorrect handling during transport may impair the product's safety and cause serious injuries and considerable material damage.

- When handling heavy weights, use lifting equipment to lift the product and transport it by appropriate means.
- Secure the product against falling during transportation and handling.
- Stand clear of suspended loads.

2.10 Malfunctions

Behavior in case of malfunctions

- Immediately remove the product from operation and report the malfunction to the responsible departments/persons.
- Order appropriately trained personnel to rectify the malfunction.
- Do not recommission the product until the malfunction has been rectified.
- Test the product after a malfunction to establish whether it still functions properly and no increased risks have arisen.

2.11 Disposal

Handling of disposal

The incorrect handling of disposal may impair the product's safety and cause serious injuries as well as considerable material and environmental harm.

- Follow local regulations on dispatching product components for recycling or proper disposal.

2.12 Fundamental dangers

General

- Observe safety distances.
- Never deactivate safety devices.
- Before commissioning the product, take appropriate protective measures to secure the danger zone.
- Disconnect power sources before installation, modification, maintenance, or calibration. Ensure that no residual energy remains in the system.
- If the energy supply is connected, do not move any parts by hand.

- Do not reach into the open mechanism or movement area of the product during operation.

2.12.1 Protection during handling and assembly

Incorrect handling and assembly

Incorrect handling and assembly may impair the product's safety and cause serious injuries and considerable material damage.

- Have all work carried out by appropriately qualified personnel.
- For all work, secure the product against accidental operation.
- Observe the relevant accident prevention rules.
- Use suitable assembly and transport equipment and take precautions to prevent jamming and crushing.

Incorrect lifting of loads

Falling loads may cause serious injuries and even death.

- Stand clear of suspended loads and do not step into their swiveling range.
- Never move loads without supervision.
- Do not leave suspended loads unattended.

2.12.2 Protection during commissioning and operation

Falling or violently ejected components

Falling and violently ejected components can cause serious injuries and even death.

- Take appropriate protective measures to secure the danger zone.
- Never step into the danger zone during operation.

2.12.3 Protection against dangerous movements

Unexpected movements

Residual energy in the system may cause serious injuries while working with the product.

- Switch off the energy supply, ensure that no residual energy remains and secure against inadvertent reactivation.
- Never rely solely on the response of the monitoring function to avert danger. Until the installed monitors become effective, it must be assumed that the drive movement is faulty, with its action being dependent on the control unit and the current operating condition of the drive. Perform maintenance work, modifications, and attachments outside the danger zone defined by the movement range.

- To avoid accidents and/or material damage, human access to the movement range of the machine must be restricted. Limit/prevent accidental access for people in this area due through technical safety measures. The protective cover and protective fence must be rigid enough to withstand the maximum possible movement energy. EMERGENCY STOP switches must be easily and quickly accessible. Before starting up the machine or automated system, check that the EMERGENCY STOP system is working. Prevent operation of the machine if this protective equipment does not function correctly.

2.12.4 Protection against electric shock

Possible electrostatic energy

Components or assembly groups may become electrostatically charged. When the electrostatic charge is touched, the discharge may trigger a shock reaction leading to injuries.

- The operator must ensure that all components and assembly groups are included in the local potential equalisation in accordance with the applicable regulations.
- While paying attention to the actual conditions of the working environment, the potential equalisation must be implemented by a specialist electrician according to the applicable regulations.
- The effectiveness of the potential equalisation must be verified by executing regular safety measurements.

2.13 Notes on particular risks



⚠ DANGER

Risk of fatal injury from suspended loads!

Falling loads can cause serious injuries and even death.

- Stand clear of suspended loads and do not step within their swiveling range.
- Never move loads without supervision.
- Do not leave suspended loads unattended.
- Wear suitable protective equipment.



⚠ WARNING

Risk of injury from objects falling and being ejected!

Falling and ejected objects during operation can lead to serious injury or death.

- Take appropriate protective measures to secure the danger zone.



⚠ WARNING

Risk of injury due to unexpected movements!

If the power supply is switched on or residual energy remains in the system, components can move unexpectedly and cause serious injuries.

- Before starting any work on the product: Switch off the power supply and secure against restarting.
- Make sure, that no residual energy remains in the system.



⚠ WARNING

Risk of injury from sharp edges and corners!

Sharp edges and corners can cause cuts.

- Use suitable protective equipment.



⚠ WARNING

Risk of burns through contact with hot surfaces!

Surfaces of components can heat up severely during operation. Skin contact with hot surfaces causes severe burns to the skin.

- For all work in the vicinity of hot surfaces, wear safety gloves.
- Before carrying out any work, make sure that all surfaces have cooled down to the ambient temperature.



⚠ WARNING

Risk of injury from parts coming loose!

If the shock absorbers are faulty, the product can become damaged. Parts coming loose in this way can lead to injuries.

- Regularly check the components for wear and damage.



⚠ WARNING

Risk of injury if the condition or behavior of the product is undefined!

Cutting off the compressed air supply in an uncontrolled manner could lead to undefined states and behavior. This may cause personal injury or material damage.

- The operator must define suitable emergency stop and restarting strategies.
 - ⇒ Emergency stop strategies: e.g. by means of controlled shut down
 - ⇒ Restarting strategies: e.g. using pressure build-up valves or suitable valve switching sequences

3 Technical data

3.1 Type key

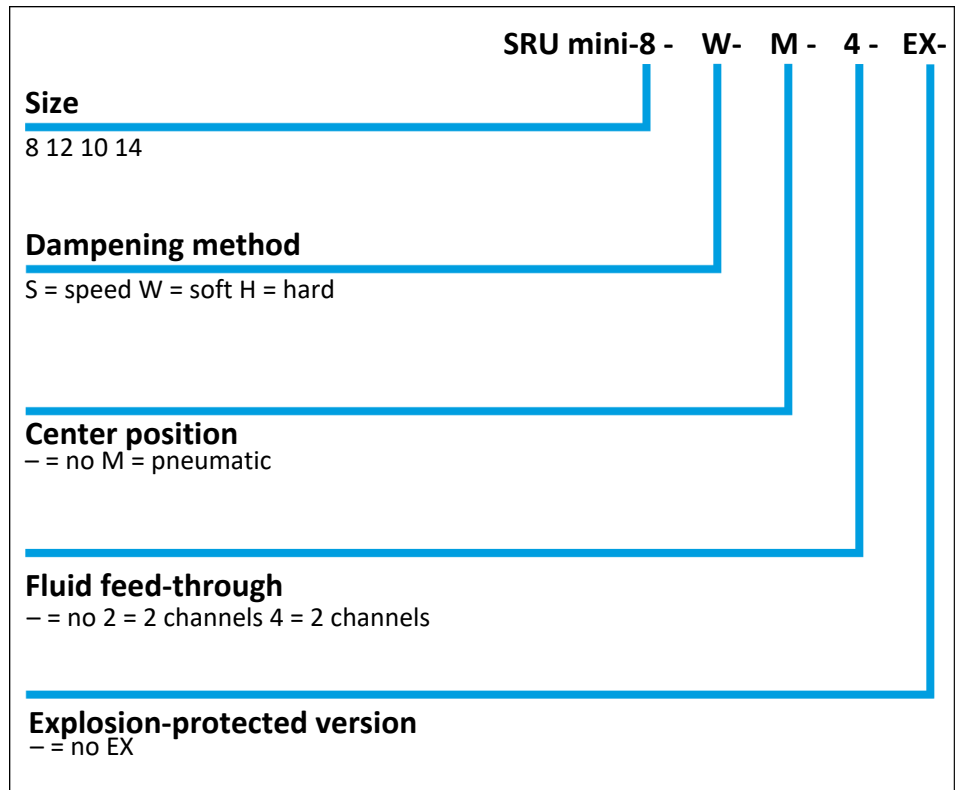

3.2 Basic data

Operating data

Designation	SRU 8, 10, 12, 14 S/H/W
Angle of rotation [°]	180
End position adjustability [°]	
Min.	-3
Max.	+90
Repeatability [mm]	< 0.07
Pressure medium	Compressed air, compressed air quality according to ISO 8573- 1:2010 [7:4:4]
Nominal operating pressure [bar]	6
Min. pressure [bar]	4.5
Max. pressure [bar]	8

More technical data is included in the catalog data sheet.
Whichever is the latest version.

Ambient conditions and operating conditions

Designation	SRU 8, 10, 12, 14 variant S/H	SRU 8, 10, 12, 14 variant W
Ambient temperature [°C]		
min.	+5	+5
max.	+60	+90
Relative air humidity [%]		
min.		35
max. (free from condensation)		85
Protection class IP *		65
Noise emission [dB(A)]		≤ 70

* For use in dirty ambient conditions (e.g. sprayed water, vapors, abrasion or processing dust) SCHUNK offers corresponding product options as standard. SCHUNK also offers customized solutions for special applications in dirty ambient conditions.

4 Design and description

4.1 Design

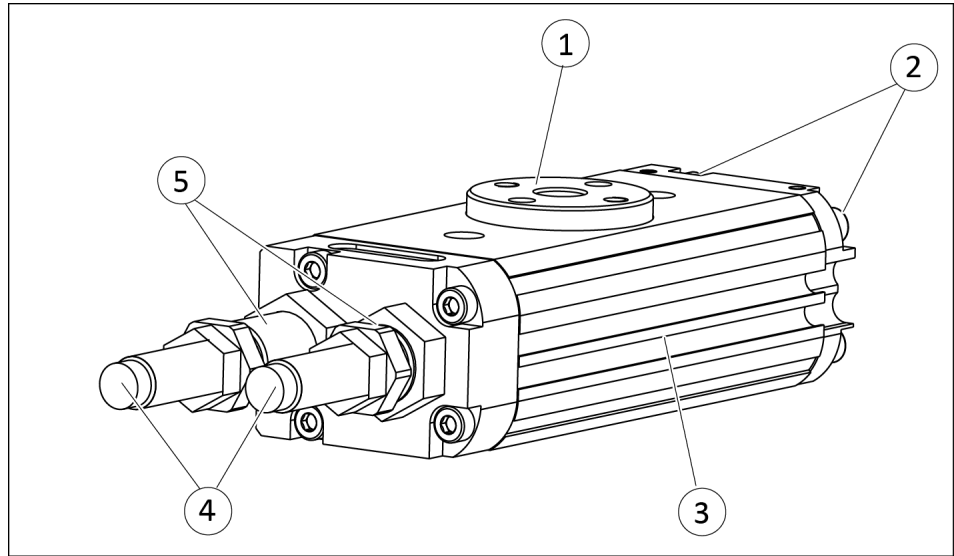

Pneumatic Rotary Unit, variant "S" displayed

1	Pinion
2	Main air connections
3	Housing with grooves for sensors
4	Shock absorbers
5	Sleeve for adjusting the end positions

4.2 Description

The product is a pneumatic miniature swivel unit for rotating and swiveling movements with various options.

- Hydraulic dampening (variant H)
- Elastomer dampening (variant S)
- Without dampening (variant W)
- Pneumatic center position (variant M)
- Fluid feed-through

5 Assembly

5.1 Assembling and connecting



⚠ DANGER

Danger of explosion in potentially explosive areas!

- Observe supplementary sheet for products with explosion-resistant versions "SRU -...-EX".



⚠ WARNING

Risk of injury due to unexpected movements!

If the power supply is switched on or residual energy remains in the system, components can move unexpectedly and cause serious injuries.

- Before starting any work on the product: Switch off the power supply and secure against restarting.
- Make sure, that no residual energy remains in the system.

NOTICE

Material damage due to faulty settings and assembly.

If the end position is approached too abruptly, the product may be damaged.

- Ensure the turning / swiveling movement is carried out without bouncing or bumping.
- Therefore provide sufficient throttling and damping.
- Please observe the information in the catalog data sheet.

NOTICE

Material damage due to opened exhaust air throttle valves!

If during first actuation the exhaust throttle valves are open, the product may move in an uncontrolled manner.

- Close the exhaust air throttle valves completely before applying pressure.

NOTE

- Observe the requirements for the compressed air supply, ▶ 3 [□ 16].
 - In case of compressed air loss (cutting off the energy line), the product loses its dynamic effects and does not remain in a secure position. However, the use of a SDV-P pressure maintenance valve is recommended in this case in order to maintain the dynamic effect for some time.
-

1. Screw the product to the machine/system, ▶ 5.2.1 [□ 20].

- ⇒ Use centering sleeves.
- ⇒ Observe the tightening torque for the mounting screws, see the following table.

2. Fasten attachment with two cylindrical pins and two fastening screws to the pinion, ▶ 5.2.1 [□ 20].

NOTICE! Insert the cylindrical pins by hand. Do not hammer the pinion.

3. In the main air connections "A" and "B", screw in throttle valves and connect compressed air lines, ▶ 5.2.2 [□ 22].

OR with hose-free direct connection:

- ⇒ Mount throttle valves in the supply lines "a" and "b".
- ⇒ Use O-rings from the accessory pack.

4. Check that all of the throttle valves are closed.

5. Screw in locking screws in open and not required air connections where appropriate.

6. Adjust end positions, ▶ 5.3.1 [□ 23].

7. Adjust center position if necessary, ▶ 5.3.2 [□ 24].

8. Mount sensor if necessary, ▶ 5.4 [□ 25].

9. Adjust swiveling speed, ▶ 6.1 [□ 28].

10. Adjust shock absorber stroke, ▶ 6.2 [□ 30].

5.2 Connections

5.2.1 Mechanical connection

Evenness of the mounting surface

The values apply to the whole mounting surface to which the product is mounted.

Edge length	Permissible unevenness
< 100	< 0.02
> 100	< 0.05

Tab.: Requirements for evenness of the mounting surface (Dimensions in mm)

Mounting

The module can be mounted from the top, from the bottom or from the side.

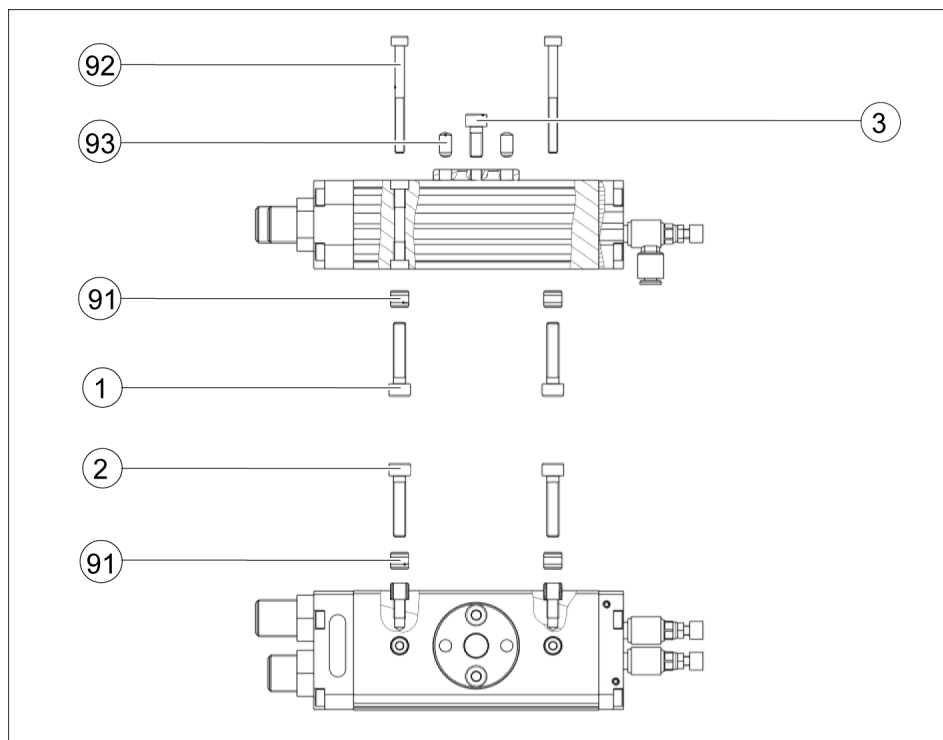

Assembly options

Item	Designation	SRU			
		8	10	12	14
91	Centering sleeves	Ø5	Ø5	Ø6	Ø6
92	Screws for fastening from above (output side)	M2.5 / 25 deep	M2.5 / 25 deep	M3 / 35 deep	M3 / 35 deep
	Max. tightening torque [Nm]	0.75	0.75	1.3	1.3
1	Screws for fastening from below (underside)	M3 / 4.5 deep	M3 / 4.5 deep	M4 / 6 deep	M4 / 6 deep
	Max. tightening torque [Nm]	1.3	1.3	3	3
2	Screws for fastening on the side	M3 / 4.5 deep	M3 / 4.5 deep	M4 / 6 deep	M4 / 6 deep
	Max. tightening torque [Nm]	1.3	1.3	3	3
3	Screws for fastening the adapter plate	M3 / 4 deep	M3 / 4 deep	M4 / 5 deep	M4 / 5 deep
	Max. tightening torque [Nm]	1.3	1.3	3	3
93	Cylindrical pin for securing the adapter plate	Ø3 x 8	Ø3 x 8	Ø4 x 8	Ø4 x 8

Tab.: Mounting material

5.2.2 Pneumatic connection

NOTICE

Avoid causing damage by approaching the end positions softly.

- Attach the one-way control valve to the product when connecting to the center position.

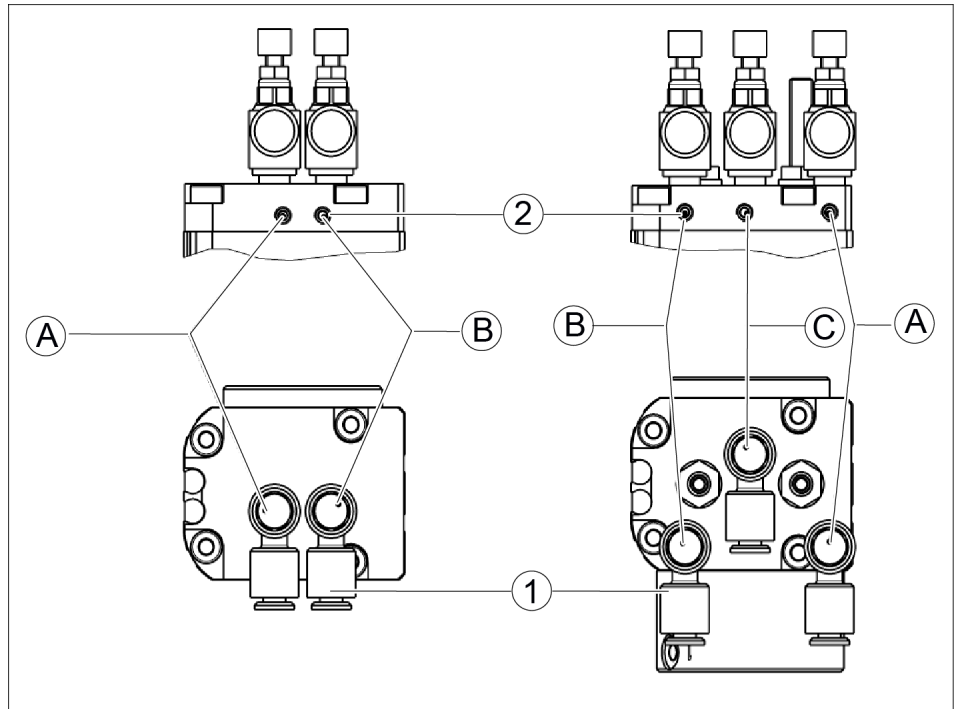

Air connections

Item	Designation	SRU			
		8	10	12	14
1	Thread diameter hose connection (A ; B ; C)			M3	
2	Thread diameter hose-free direct connection on base side (a ; b ; c)			M3	
A	Hose connection für swiveling clockwise				
B	Hose connection für swiveling counter-clockwise				
C	Hose connection for swiveling in center position				

Tab.: Thread diameter of the air connections

Further information on the hose-free direct connection contains the catalog data sheet.

5.3 Settings

5.3.1 Adjustment of the end positions

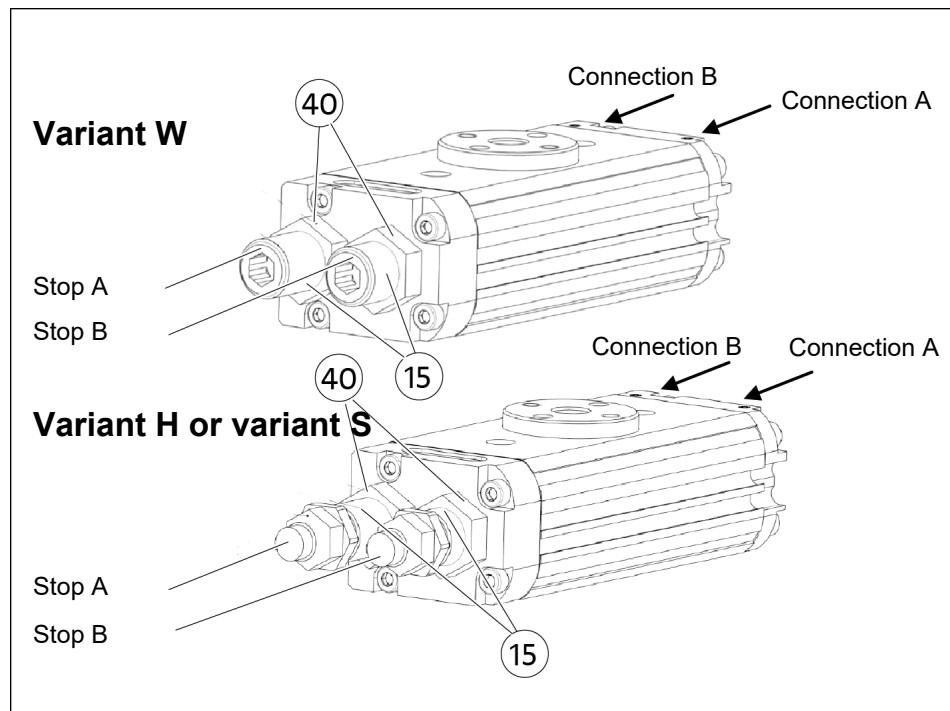

Adjustment of the end positions

1. Apply pressure to connection A until the rotary unit has reached its end position.
2. Loosen the lock nut (40) at stop B.
3. Set the end position with sleeve B (5) and stop B (15).
4. Hold sleeve B (5) and stop B (15) tight and tighten the lock nut (40).
5. Check the end positions.
6. Apply pressure to connection B until the rotary unit has reached its end position.
7. Loosen the lock nut (40) at stop A.
8. Set the end position with sleeve A (5) and stop A (15).
9. Hold sleeve A (5) and stop A (15) tight and tighten the lock nut (40).
10. Check the end positions.

NOTE

When the lock nut (40) is loosened, air can escape at the sleeve (5) and at the stop (15). This is due to the design and is normal.

5.3.2 Adjustment of the central position (Variant M)

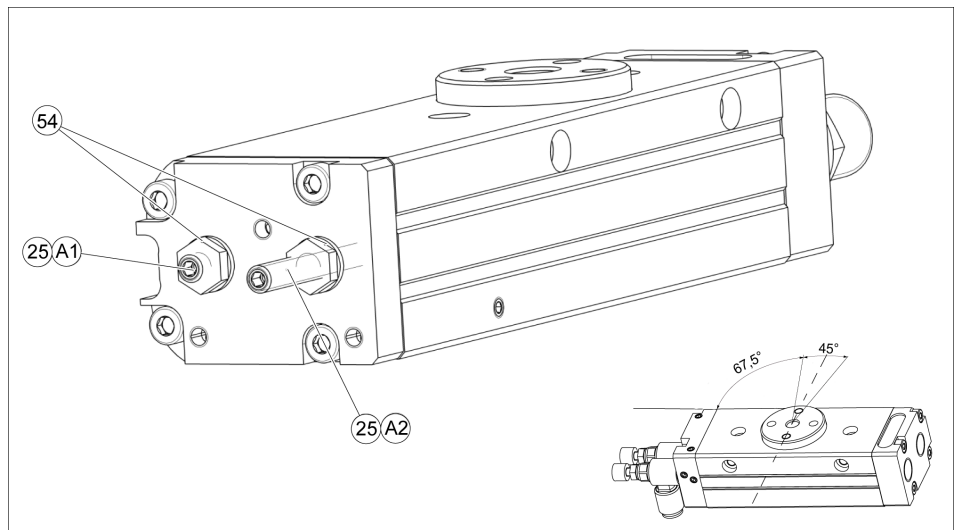

Adjustment of the central position

- 1.** Depressurize connections A and B.
- 2.** Apply air pressure to connection C.
- 3.** Loosen the lock nuts (54) of the stop spindles (25).
- 4.** Unscrew stop A2 as far as possible.
- 5.** Turn the pinion clockwise and keep it pressed against stop A1.
- 6.** Turn stop A1 until the desired central position has been reached.
- 7.** Turn stop A2 until there is no more play in the pinion in the central position.
- 8.** Retighten the lock nuts (54) of the stop spindles (25).
- 9.** Rotate several times to check the correct setting of the central position.

5.4 Installing the sensors



⚠ DANGER

Danger of explosion in potentially explosive areas!

- Observe supplementary sheet for products with explosion-resistant versions "SRU -...-EX".

NOTE

Observe the assembly and operating manual of the sensor for mounting and connecting.

The product is prepared for the use of sensors.

- For the exact type designations of suitable sensors, please see catalog datasheet and ▶ 5.4.1 [📄 25].
- For technical data for the suitable sensors, see assembly and operating manual and catalog datasheet.
 - The assembly and operating manual and catalog datasheet are included in the scope of delivery for the sensors and are available at schunk.com.
- Information on handling sensors is available at schunk.com or from SCHUNK contact persons.

5.4.1 Overview of sensors

Designation	SRU			
	8	10	12	14
Magnetic switch MMS 22	X	X	X	X
Programmable magnetic switch MMS 22-PI1	X	X	X	X

5.4.2 Mounting MMS 22 magnetic switch

NOTICE

Material damage due to an incorrect tightening torque!

If the threaded pin is tightened with an incorrect tightening torque, the product may be damaged.

- Observe a maximum tightening torque of 10 Ncm for the set-screws.

Two groves have been worked into the housing to mount the sensors.

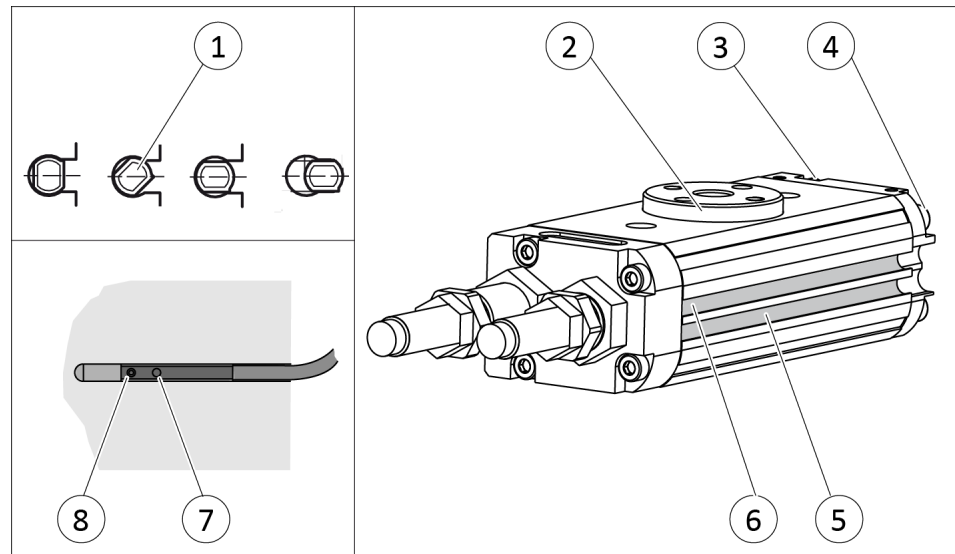

1. Connect sensor and secure cable, see the Sensor Assembly and Operating Manual.
2. Apply air pressure to connection "A" (4).
⇒ Pinion (2) swivels towards the end position.
3. Insert or screw the first sensor (1) into the groove (5).
4. Move the sensor along the groove until it actuates.
5. Tighten set screw (8).
⇒ Tightening torque: 10 Ncm
6. Bleed connection "A" (4).
7. Actuate connection "B" (3).
⇒ Pinion (2) swivels into the other end position.
8. Insert or screw the second sensor (1) into the groove (6).
9. Move the sensor along the groove until it actuates.
10. Tighten set screw (8).
⇒ Tightening torque: 10 Ncm
11. Check the switching position and test its function.

Center position variant

Rotate unit in the center position and mount sensor analogously.

5.4.3 Mounting MMS 22-PI1 programmable magnetic switch

NOTICE

Material damage due to an incorrect tightening torque!

If the threaded pin is tightened with an incorrect tightening torque, the product may be damaged.

- Observe a maximum tightening torque of 10 Ncm for the set-screws.

Two groves have been worked into the housing to mount the sensors.

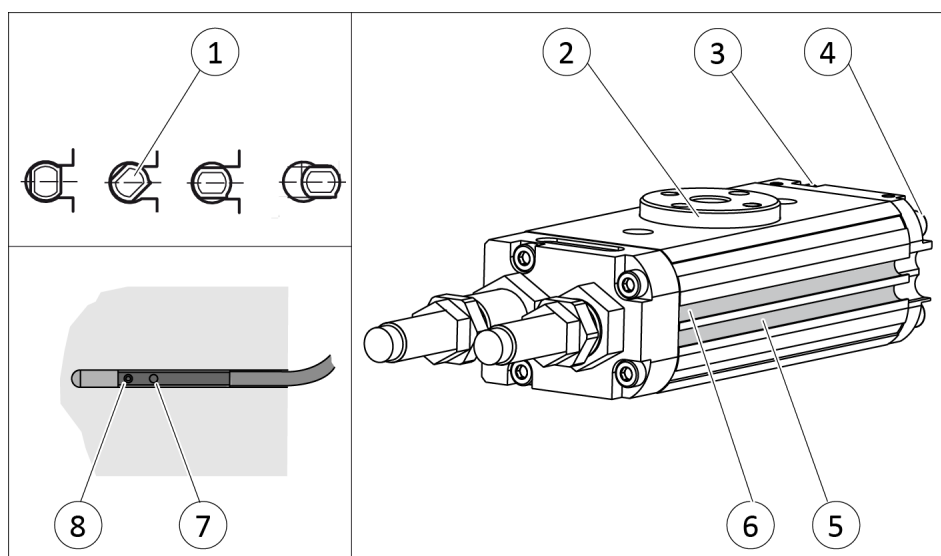

1. Connect sensor and secure cable, see the Sensor Assembly and Operating Manual.
2. Apply air pressure to connection "A" (4).
⇒ Pinion (2) swivels towards the end position.
3. Hold teaching tool to the sensor (1) until the sensor flashes.
4. Insert or screw the sensor (1) into the groove (5), until the sensor flashes rapidly.
5. Tighten set screw (8).
⇒ Tightening torque: 10 Ncm
6. Bleed connection "A" (4).
7. Actuate connection "B" (3).
⇒ Pinion (2) swivels into the other end position.
8. Repeat steps for the second sensor.
9. Check the switching position and test its function.

Center position variant

Rotate unit in the center position and mount sensor analogously.

6 Commissioning

NOTICE

Damage to the rotary module possible!

The rotary module can be damaged if it arrives too abruptly in the end position.

- The rotary motion must reach the end position without jerk or bounce.
- Therefore flow control valves and shock absorbers must be used, ▶ 6.1 [28] and ▶ 6.2 [30].
- Please observe the information in the catalog pages.

6.1 Setting the speed

NOTICE

Material damage due to erroneous settings!

If the end position is approached too hard, the product may be damaged.

- Adjust exhaust throttle valve and shock absorber so that the movement is braked smoothly.

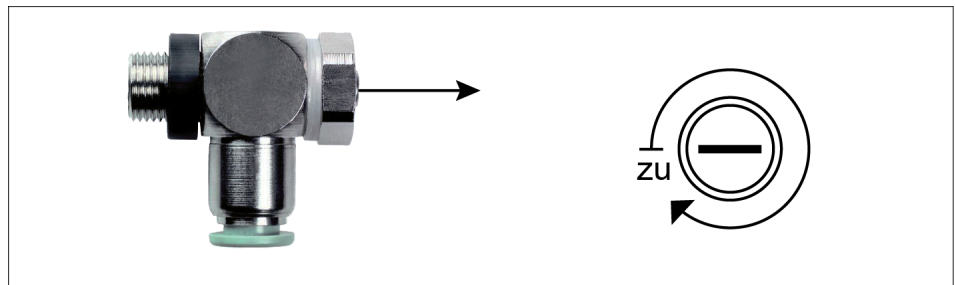

1. Close exhaust throttle valve completely.

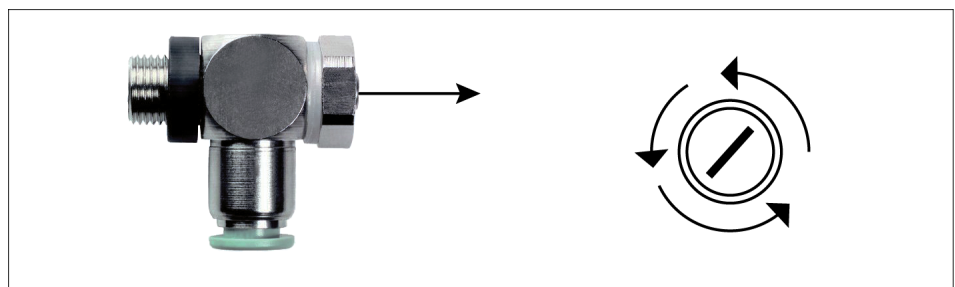

2. Open exhaust throttle valve until the product starts to move.

3. Continue to open the exhaust throttle valve incrementally until the movement decelerates smoothly.
 - ⇒ If the speed is too low, the product will brake too soon and the end position will be reached too slowly.
 - ⇒ If the speed is too high, the product will impact against the end position and the shock absorber will be overloaded.

NOTE

A smooth motion may also be too slow in many use-cases. Further settings can be made via the shock absorbers, ► [6.2 \[30\]](#).

6.2 Adjustment of the shock absorber stroke

NOTE

When received from the factory, the unit is set to utilize the maximum shock absorber stroke.

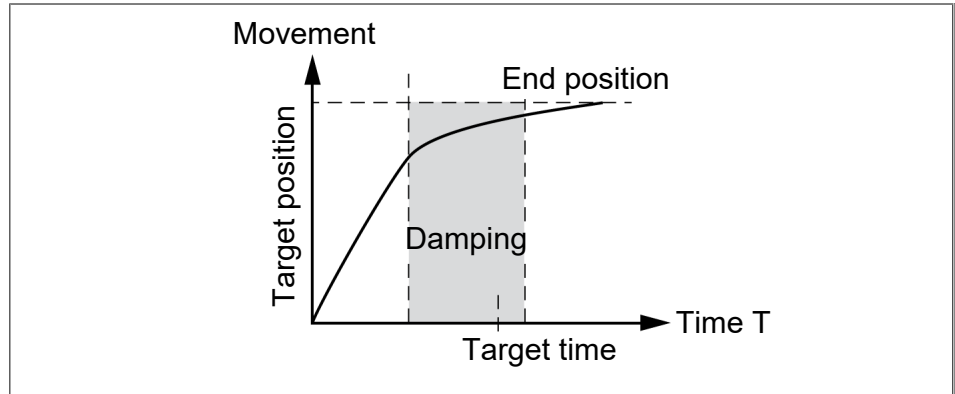

The shock absorber stroke is too long and the end position is reached too slowly.



The shock absorber stroke is too short and the unit arrives in the end position too abruptly.

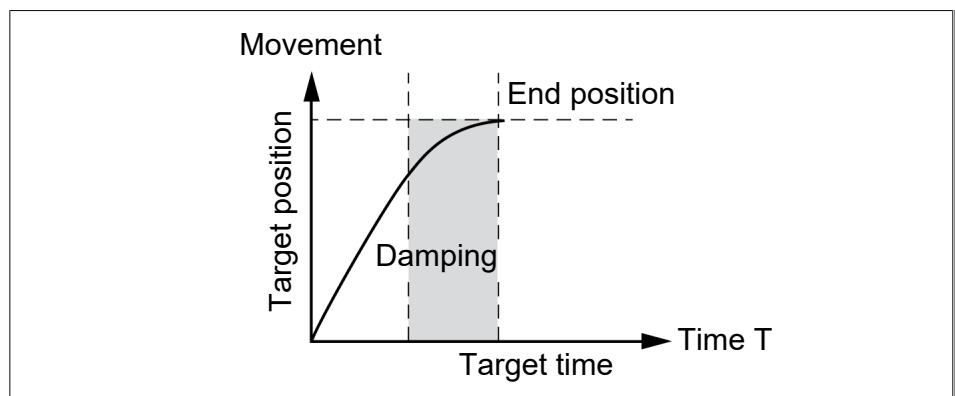

Optimal shock absorber stroke.

6.2.1 Shock absorber stroke (variant H)

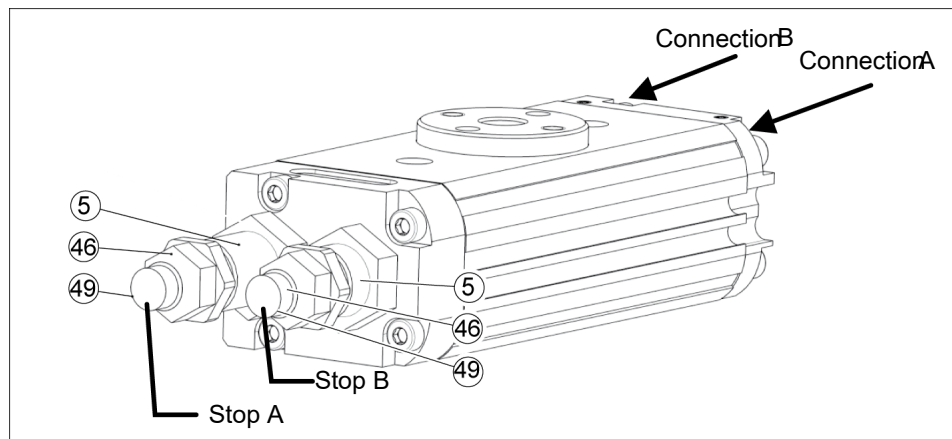

Adjusting the shock absorber

Adjusting the dampening for end position 0°

1. Apply air pressure to connection A.
2. Loosen the counter nut (46) from the stop B, by holding the sleeve (5).
3. Unscrew the shock absorber (49) to decrease dampening and swiveling time.
4. Load and rotate the product to check the shock absorption effect. **NOTICE! The end position must be reached gently, ▶ 6.2 [30].**
5. Hold on to the sleeve (5) and shock absorber (49) and tighten the counter nut (46).

Adjusting the dampening for end position 180°

1. Apply air pressure to connection B.
2. Loosen the counter nut (46) from the stop A, by holding the sleeve (5).
3. Unscrew the shock absorber (49) to decrease dampening and swiveling time.
4. Load and rotate the product to check the shock absorption effect. **NOTICE! The end position must be reached gently, ▶ 6.2 [30].**
5. Hold on to the sleeve (5) and shock absorber (49) and tighten the counter nut (46).

NOTE

Air can escape from the shock absorber (49) if the counter nut (40) is loosened. This is normal and part of the design.

6.2.2 Shock absorber stroke (variant S)

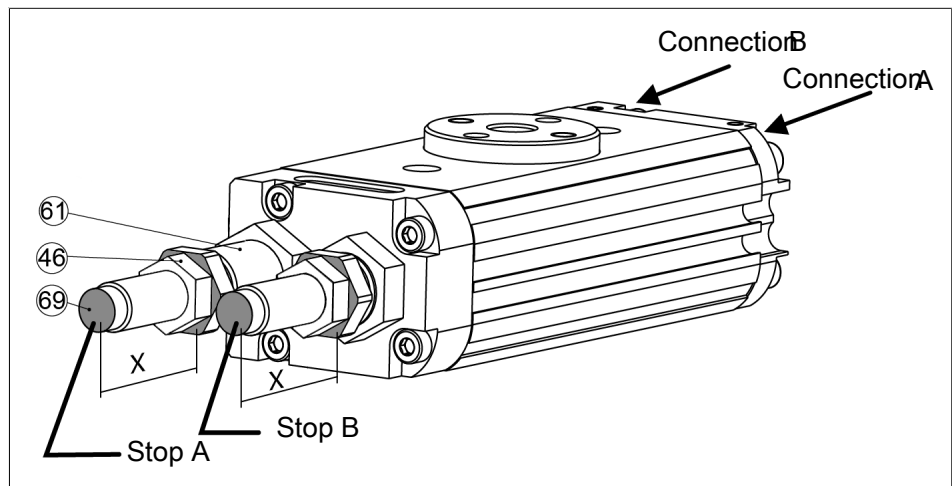

Adjustment of the shock absorber

Pos. X	SRU		
	10	12	14
Maximum screw-in depth of the shock absorber [mm]	20.5	24	34

Setting the shock absorption for end position 0°

1. Apply air pressure to connection A.
2. Loosen lock nut (46) on stop B, providing counter support for the sleeve (61).
3. Unscrew the shock absorber (69) to decrease shock absorption and rotation time.
4. Load and swivel module to check damping effect. **NOTICE!** The end position must be approached softly, ▶ 6.2 [30]
5. Hold sleeve (61) and shock absorber (69) tight and retighten the lock nut (46).

Setting the shock absorption for end position 180°

1. Apply air pressure to connection B.
2. Loosen lock nut (46) on stop A, providing counter support for the sleeve (61).
3. Unscrew the shock absorber (69) to decrease shock absorption and rotation time.
4. Load and swivel module to check damping effect. **NOTICE!** The end position must be approached softly, ▶ 6.2 [30]
5. Hold sleeve (61) and shock absorber (69) tight and retighten the lock nut (46) firmly.

NOTE

When the lock nut (40) is loosened, air can escape at the shock absorber (49). This is due to the design and is normal.

7 Troubleshooting

7.1 Product does not move

Possible cause	Corrective action
Pressure drops below minimum.	Check air supply. ▶ 5.2.2 [22]
Compressed air lines switched.	Check compressed air lines. ▶ 5.2.2 [22]
Proximity switch defective or set incorrect.	Readjust or change sensor.
Unused air connections open.	Close unused air connections.
Flow control valve closed.	Open the flow control valve.
Component part defective.	Replace component or send it to SCHUNK for repair.

7.2 Product does not travel through the entire stroke

Possible cause	Corrective action
Accumulation of dirt between stop / sleeve and pistons.	Clean and if necessary re-lubricate. ▶ 8 [35]
End positions are adjusted incorrectly.	Adjust end position. ▶ 5.3.1 [23]
Pressure drops below minimum.	Check air supply. ▶ 3 [16]
Mounting surface is not sufficiently flat.	Check the evenness of the mounting surface. ▶ 5.2.1 [20]
Component part defective.	Send product with a SCHUNK repair order or dismantle product.

7.3 Product rotates jerkily

Possible cause	Corrective action
Too little grease in the mechanical guiding areas.	Clean and lubricate product., ▶ 8 [35]
Compressed air lines blocked.	Check compressed air lines of damage.
Mounting surface is not sufficiently flat.	Check the evenness of the mounting surface.
One-way flow control valve is missing or adjustet incorrectly.	Install and adjust one-way flow control valve.
Loading too large.	Check the permissible weight., ▶ 5.2.1 [20]

7.4 Torque diminishes?

Possible cause	Corrective action
Compressed air can escape.	Check seals, if necessary, disassemble the product and replace seals. ▶ 8.4.1 [37]
Too much grease in the mechanical movement space.	Clean and lubricate product. ▶ 8 [35]
Pressure drops below minimum.	Check air supply. ▶ 5.2.2 [22]

8 Maintenance

8.1 Notes



⚠ DANGER

Danger of explosion in potentially explosive areas!

- Observe supplementary sheet for products with explosion-resistant versions "SRU -...-EX".

Original spare parts

Use only original spare parts of SCHUNK when replacing spare and wear parts.

8.2 Maintenance interval

NOTICE

Material damage due to hardening lubricants!

Lubricants harden more quickly at temperatures above 60°C, leading to possible product damage.

- Reduce the lubricant intervals accordingly.

Interval (million cycles) for SRU 8 - 14	Maintenance work
2	Clean all parts thoroughly, check for damage and wear, if necessary replace seals and wearing parts, ▶ 8.4 [□ 37]. <ul style="list-style-type: none"> • Position of the wearing parts, ▶ 8.4.4 [□ 38] • Seal kit, ▶ 1.4.1 [□ 7]
2	Treat all grease areas with lubricant. Oil or grease external steel parts. ▶ 8.3 [□ 36].
2	For H variant: Check that the shock absorber is working, if necessary replace the shock absorber, ▶ 8.4 [□ 37].
2	For S variant: Check that the elastomer is working, if necessary replace the elastomer, ▶ 8.4 [□ 37].

8.3 Lubricants/Lubrication points (basic lubrication)

During maintenance, treat all greased areas with lubricant. Thinly apply lubricant with a lint-free cloth.

SCHUNK recommends the lubricants listed.

Lubricant point	Lubricant
The teeth and the pinion	SCHUNK grease 9
Seals and sealing surfaces	SCHUNK grease 9

Details regarding SCHUNK lubricant designations are available at [schunk.com/lubricants](https://www.schunk.com/lubricants).

The product contains food-compliant lubricants as standard. Components such as rolling bearings, linear guides, or shock absorbers are not provided with food-compliant lubricants.

The requirements of standard EN 1672-2:2020 are not fully met.

NOTE

- Change contaminated food-compliant lubricant.
 - Observe information in the safety data sheet from the lubricant manufacturer.
-

8.4 Disassembly and assembly

8.4.1 Dismantle product

Position of the item numbers ▶ 8.4.4 [38]



⚠ WARNING

Risk of injury due to unexpected movements!

If the power supply is switched on or residual energy remains in the system, components can move unexpectedly and cause serious injuries.

- Before starting any work on the product: Switch off the power supply and secure against restarting.
- Make sure, that no residual energy remains in the system.

1. Remove the compressed air lines.
2. Unscrew the screws (34) and remove cover 1 (3).
3. Unscrew the screws (60) and remove cover 2 (14).
4. Mark the installation position of the piston (2) and the pinion (6 / 16).
5. Version with media feed-through: Unscrew screws (41) and remove cover (18).
6. Disassemble the safety ring (33) from the pinion.
7. SRU 8 and SRU 10: remove washer (7).
8. Push the pinion (6 / 16) out of the housing.
9. Service the module.

8.4.2 Notes for assembly

Assembly takes place in the opposite order to disassembly. Observe the following:

- Unless otherwise specified, secure all screws and nuts with Loctite no. 243 and tighten with the appropriate tightening torque. ▶ 8.4.3 [38]

NOTICE

Material damage due to incorrect assembly!

The O-rings (42) can become damaged during assembly.

- Install the cover for the internal air feed-through (18) carefully.
- The cover for the internal air feed-through (18) can be installed rotated by 180°, if required.

8.4.3 Tightening torque for screws

Position of the item numbers ▶ 8.4.4 [📄 38]

Item	SRU			
	8	10	12	14
34	0.75	0.75	1.3	1.3
41	0.75	0.75	1.3	1.3
60	0.75	0.75	1.3	1.3

Tab.: Specified in Nm

8.4.4 Assembly drawing

The following figures are example images.

They serve for illustration and assignment of the spare parts.

Variations are possible depending on size and variant.

- * Wearing part, replace during maintenance. Included in the seal kit. Seal kit can only be ordered completely.
- ** only for SRU 8 and SRU 10

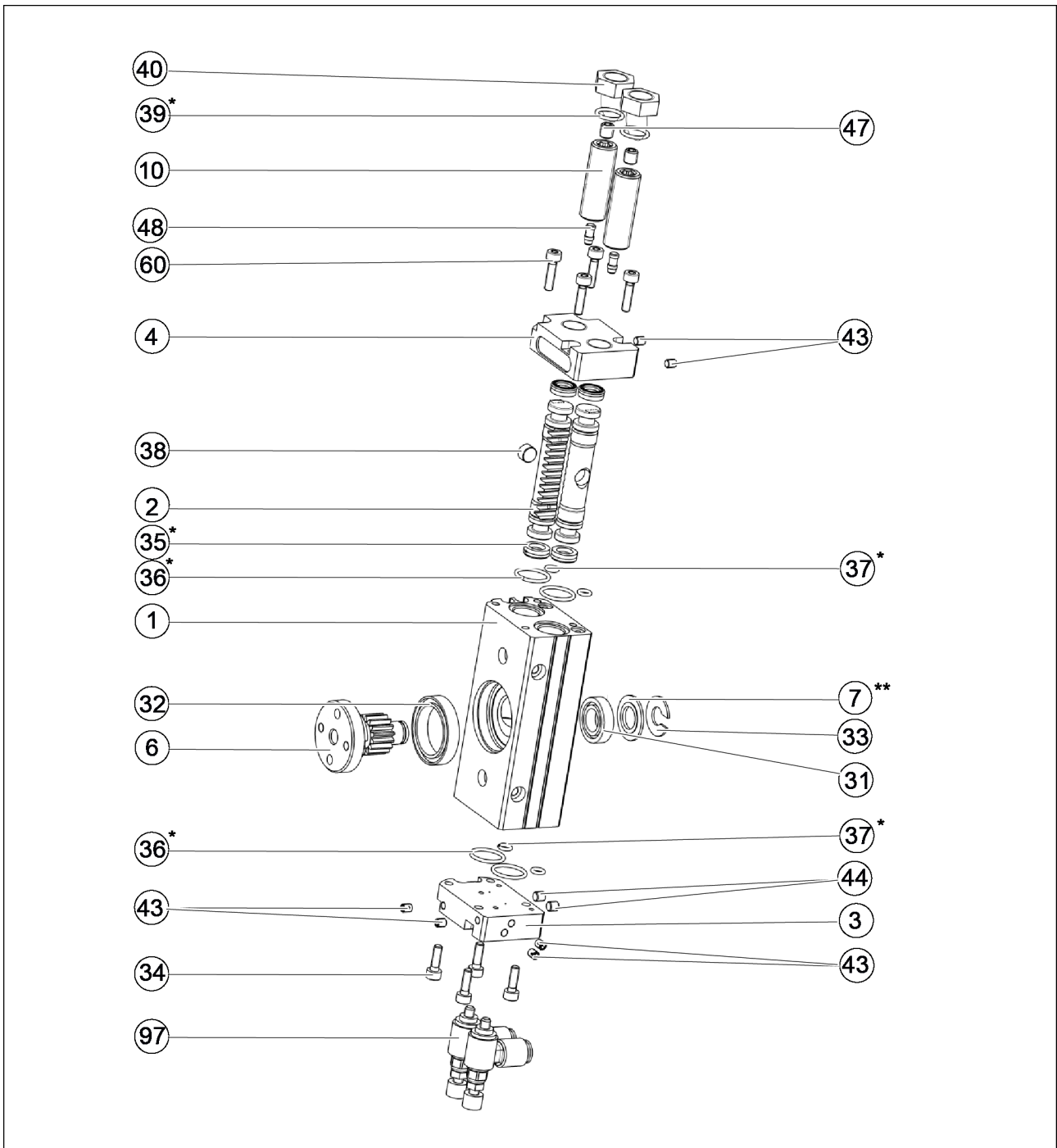

Assembly of swivel unit

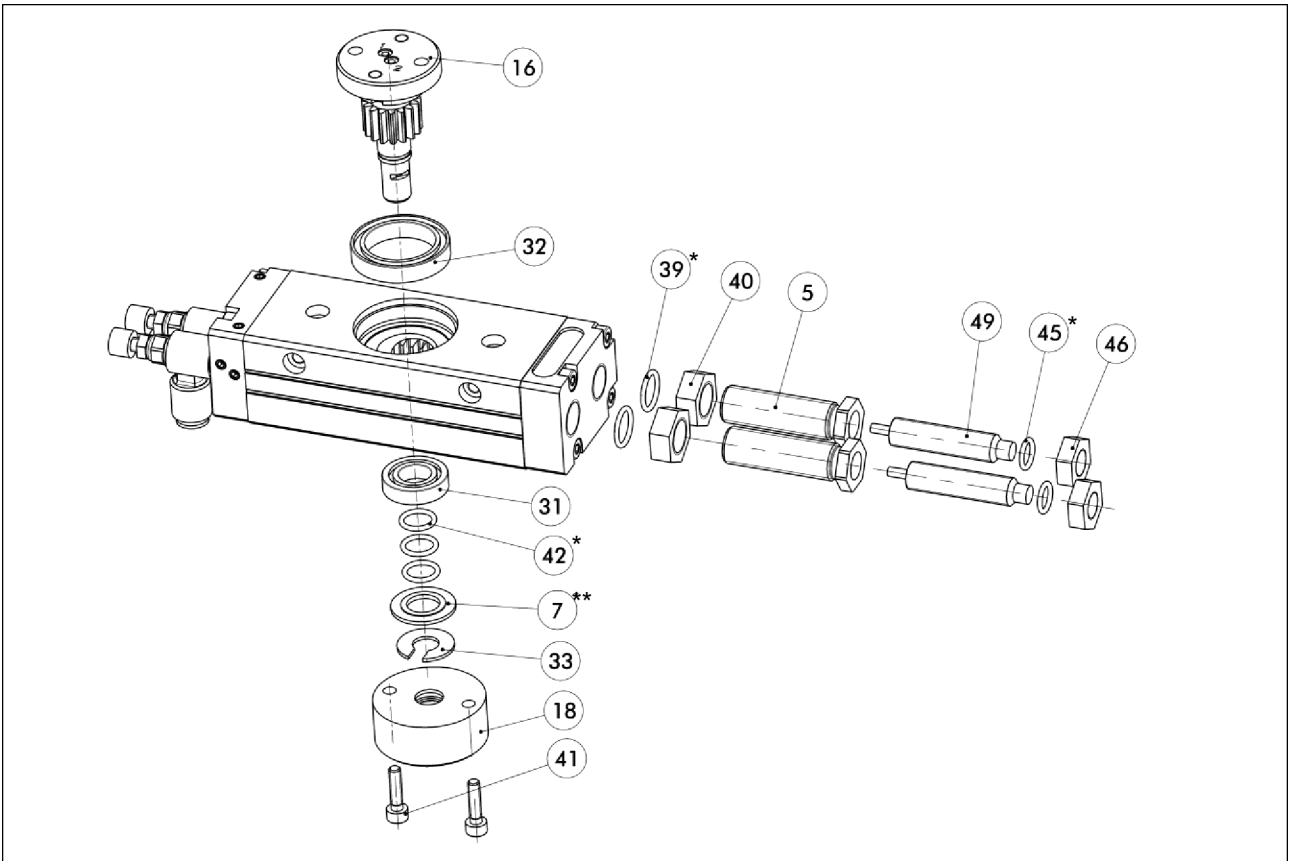

Assembly of fluid feed-through and hydraulic damping

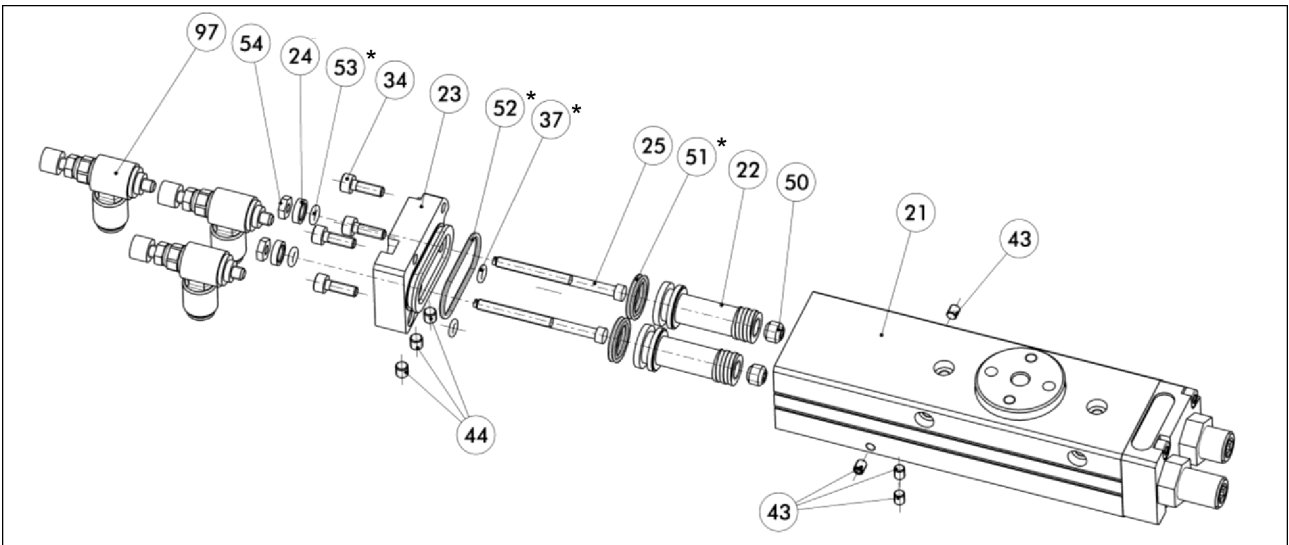

Assembly of swivel unit with center position

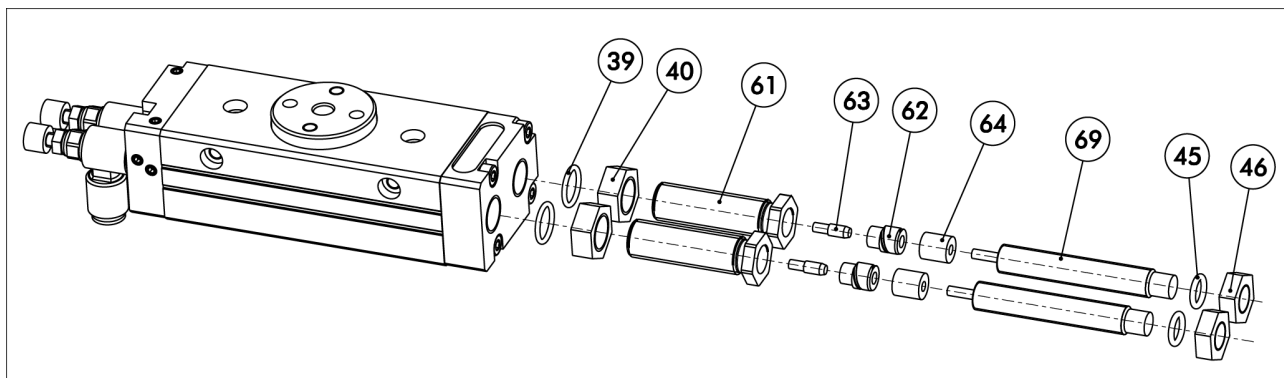

Assembly of swivel unit with damper elastomer damping

9 Translation of the original declaration of incorporation

in terms of the Directive 2006/42/EG, Annex II, Part 1 Section B.

Manufacturer/
Distributor SCHUNK SE & Co. KG
Spanntechnik | Greiftechnik | Automatisierungstechnik
Bahnhofstr. 106 – 134
D-74348 Lauffen/Neckar

We hereby declare that the partly completed machine described below

Product designation: Pneumatic Rotary Unit / SRU /pneumatic
ID number 0356810...0356877; 0356930...0356973

meets the following basic occupational health and safety of the Machinery Directive 2006/42/EC:

No. 1.1.1, No. 1.1.2, No. 1.1.3, No. 1.1.5, No. 1.3.2, No. 1.5.3, No. 1.5.4, No. 1.5.6, No. 1.5.8, No. 1.5.10, No. 1.5.11, No. 1.5.13

The partly completed machinery may not be put into operation until it has been confirmed that the machine into which the partly completed machinery is to be installed complies with the provisions of the Machinery Directive (2006/42/EC). The declaration shall be rendered invalid if modifications are made to the product.

Applied harmonized standards, especially:

EN ISO 12100:2010 Safety of machinery – General principles for design –
Risk assessment and risk reduction

The special technical documentation according to Annex VII, Part B, belonging to the partly completed machine, has been created.

Person authorized to compile the technical documentation:
Stefanie Walter, Address: see manufacturer's address

Signature: see original declaration

Lauffen/Neckar, March 2024

Dr.-Ing. Manuel Baumeister,
Head of Systems Engineering,
Technology & Innovation

10 UKCA declaration of incorporation

in accordance with the Supply of Machinery (Safety) Regulations 2008.

Manufacturer/ Distributor	SCHUNK Intec Limited Clamping and gripping technology 3 Drakes Mews, Crownhill MK8 0ER Milton Keynes
------------------------------	---

We hereby declare that on the date of the declaration the following partly completed machine complied with all basic safety and health regulations found in the "Supply of Machinery (Safety) Regulations 2008".

The declaration shall be rendered invalid if modifications are made to the product.

Product designation:	Pneumatic Rotary Unit / SRU / pneumatic
ID number	0356810...0356877; 0356930...0356973

The partly completed machine may not be put into operation until it has been confirmed that the machine into which the partly completed machine is to be installed complies with the provisions of the "Supply of Machinery (Safety) Regulations 2008".

Applied harmonized standards, especially:

EN ISO 12100:2010	Safety of machinery – General principles for design – Risk assessment and risk reduction
-------------------	---

The special technical documentation according to Annex VII, Part B, belonging to the partly completed machine, has been created.

Person authorized to compile the technical documentation:
Marcel Machado, address: refer to manufacturer's address



Lauffen/Neckar, March 2024

Dr.-Ing. Manuel Baumeister,
Head of Systems Engineering,
Technology & Innovation

11 Information on the RoHS Directive, REACH Regulation and Substances of Very High Concern (SVHC)

RoHS Directive

SCHUNK products are classified as "large-scale stationary installations" or as "large-scale stationary industrial tools" within the meaning of Directive 2011/65/EU and its extension 2015/863/EU "on the restriction of the use of certain hazardous substances in electrical and electronic equipment (RoHS)", or fulfill their intended function only as part of one. Therefore products from SCHUNK do not fall within the scope of the directive at this time.

REACH Regulation

Products from SCHUNK fully comply with the regulations of Regulation (EC) No. 1907/2006 "concerning the Registration, Evaluation, Authorization and Restriction of Chemicals (REACH)" and its amendment 2022/477. SCHUNK attaches great importance to completely avoiding chemicals of concern to humans and the environment wherever possible.

Only in rare exceptional cases do SCHUNK products contain SVHC substances on the candidate list with a mass content above 0.1%. In accordance with Article. 33 (1) of Regulation (EC) No. 1907/2006, SCHUNK complies with its duty to "communicate information on substances in articles" and lists the components concerned and the substances used in an overview that can be viewed at [schunk.com/SVHC](https://www.schunk.com/SVHC).

Signature: see original declaration

Lauffen/Neckar, March 2024

Dr.-Ing. Manuel Baumeister,
Head of Systems Engineering,
Technology & Innovation

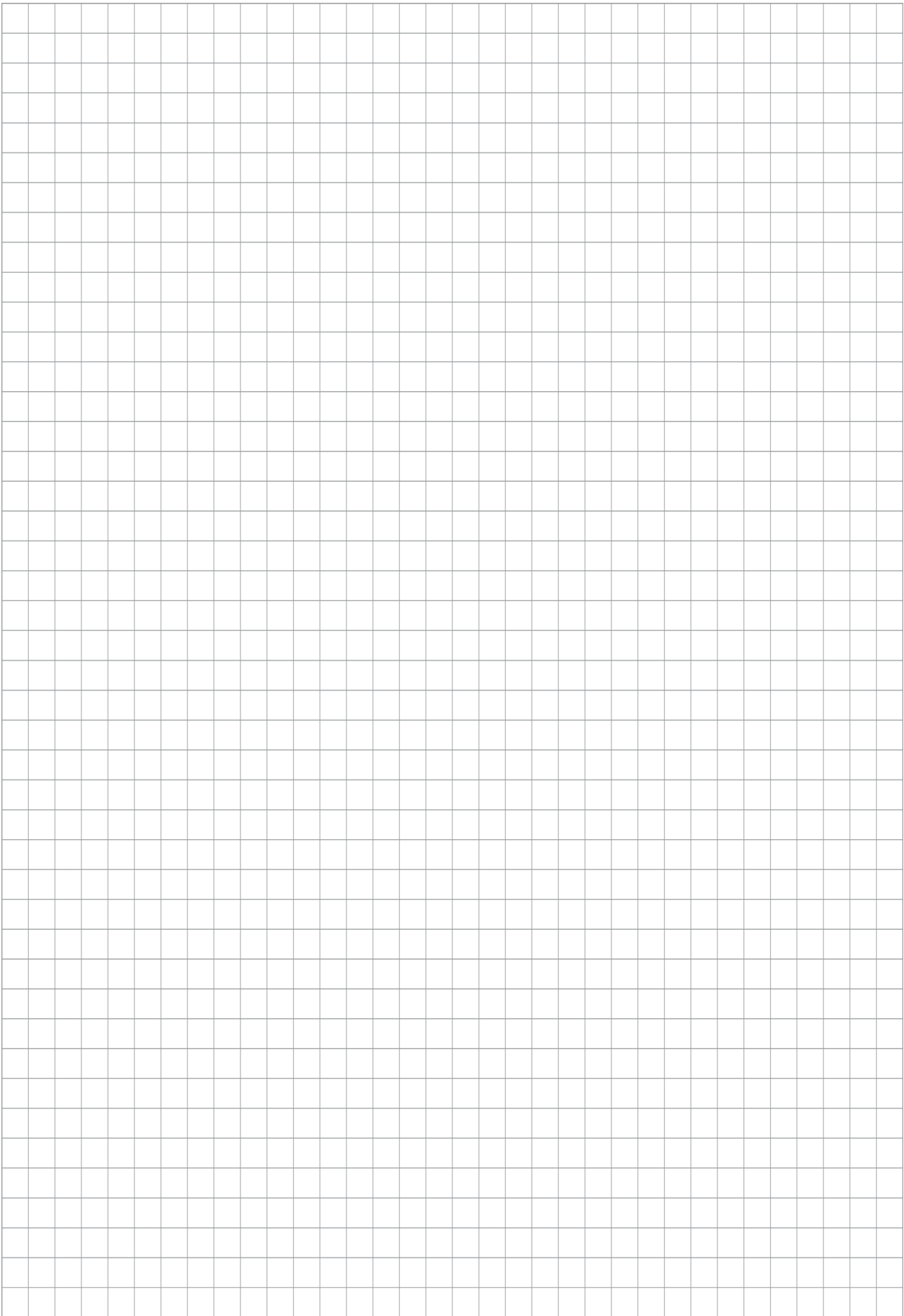

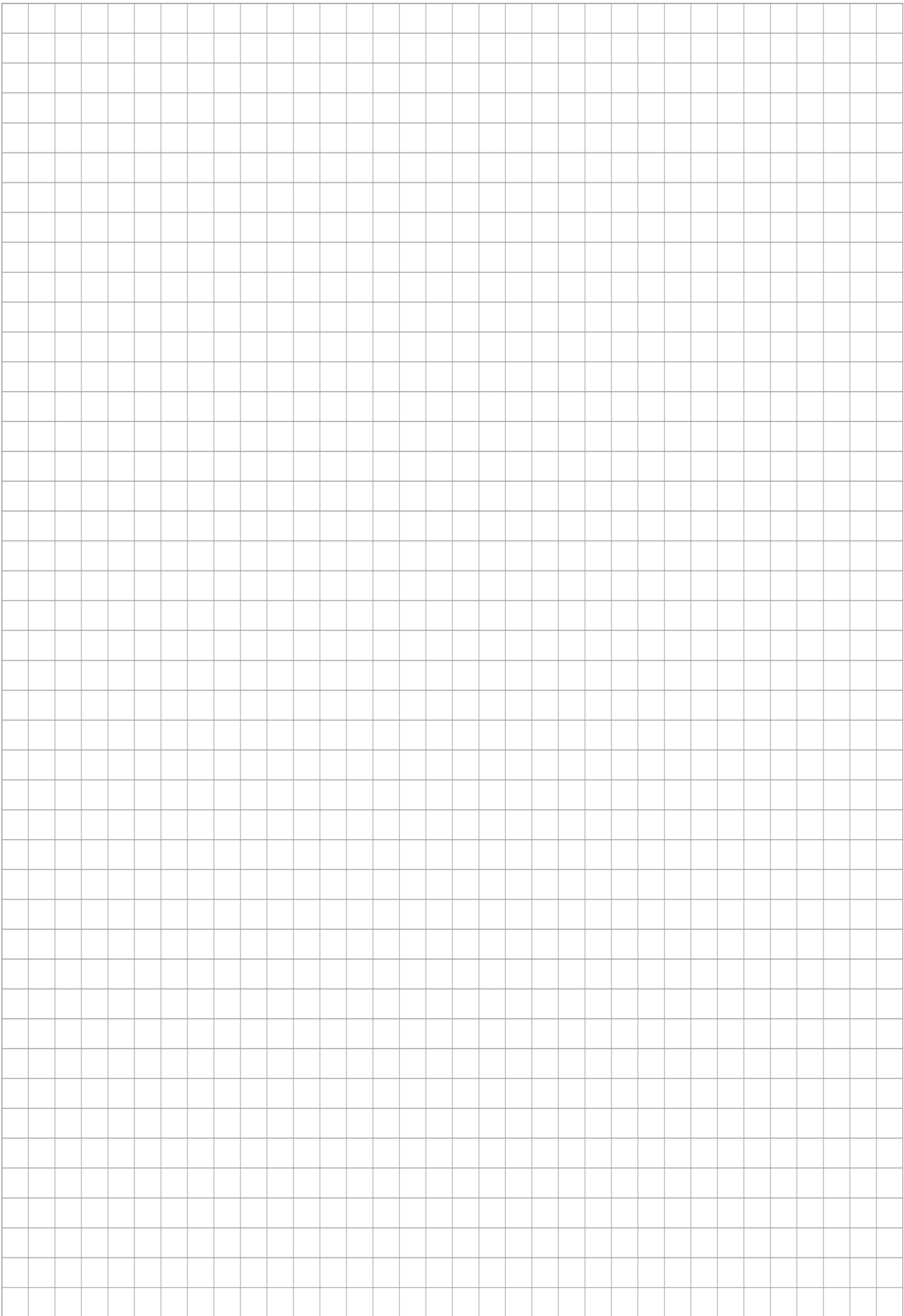





SCHUNK SE & Co. KG
Spanntechnik | Greiftechnik | Automatisierungstechnik

Bahnhofstr. 106 - 134
D-74348 Lauffen/Neckar
Tel. +49-7133-103-0
info@de.schunk.com
schunk.com

Folgen Sie uns | *Follow us*



Wir drucken nachhaltig | *We print sustainable*