

Assembly and operating manual

KONEX H

Plastic pneumatic linear unit



Imprint

Copyright:

This manual is protected by copyright. The author is SCHUNK GmbH & Co. KG. All rights reserved. Any reproduction, processing, distribution (making available to third parties), translation or other usage - even excerpts - of the manual is especially prohibited and requires our written approval.

Technical changes:

We reserve the right to make alterations for the purpose of technical improvement.

Document number: 389175

Version: 06.00 | 12/05/2020 | en

© SCHUNK GmbH & Co. KG

All rights reserved.

Dear Customer,

thank you for trusting our products and our family-owned company, the leading technology supplier of robots and production machines.

Our team is always available to answer any questions on this product and other solutions. Ask us questions and challenge us. We will find a solution!

Best regards,

Your SCHUNK team

SCHUNK GmbH & Co. KG
Clamping and gripping technology

Bahnhofstr. 106 - 134
D-74348 Lauffen/Neckar

Tel. +49-7133-103-0
Fax +49-7133-103-2399

info@de.schunk.com
schunk.com

Table of Contents

1	General	5
1.1	About this manual	5
1.1.1	Presentation of Warning Labels	5
1.1.2	Applicable documents	6
1.2	Warranty	6
1.3	Scope of delivery	6
1.3.1	Accessory pack.....	6
1.4	Accessories	7
1.4.1	Sensors	7
1.4.2	Seal kit	7
2	Basic safety notes	8
2.1	Intended use.....	8
2.2	Not intended use	8
2.3	Constructional changes	8
2.4	Spare parts	8
2.5	Ambient conditions and operating conditions	8
2.6	Personnel qualification	9
2.7	Personal protective equipment.....	9
2.8	Notes on safe operation	10
2.9	Transport	10
2.10	Malfunctions.....	10
2.11	Disposal	11
2.12	Fundamental dangers.....	11
2.12.1	Protection during handling and assembly	11
2.12.2	Protection during commissioning and operation	12
2.12.3	Protection against dangerous movements.....	12
2.12.4	Protection against electric shock.....	13
2.13	Notes on particular risks.....	14
3	Technical data	15
4	Assembly	16
4.1	Connections.....	16
4.1.1	Mechanical connection.....	16
4.1.2	Pneumatic connection	17
4.2	Mounting the sensor	18
4.2.1	MMS 30 magnetic switch	18

5	Maintenance	20
5.1	Notes	20
5.2	Maintenance and lubrication intervals.....	20
5.3	Lubricants/Lubrication points (basic lubrication)	20
5.4	Disassembly of the module	20
5.5	Servicing and assembling the module	21
5.6	Disposal	21
5.7	Assembly drawing.....	22
6	Connection technique	23
6.1	Assembly / Disassembly of the Module	23
6.2	Connection	23
6.3	Loosen the connection in a „one second“- cycle time	24
7	Translation of original declaration of incorporation	25
7.1	Annex to Declaration of Incorporation.....	26

1 General

1.1 About this manual

This manual contains important information for a safe and appropriate use of the product.

This manual is an integral part of the product and must be kept accessible for the personnel at all times.

Before starting work, the personnel must have read and understood this operating manual. Prerequisite for safe working is the observance of all safety instructions in this manual.

Illustrations in this manual are provided for basic understanding and may differ from the actual product design.

In addition to these instructions, the documents listed under [Applicable documents](#) [► 6] are applicable.

1.1.1 Presentation of Warning Labels

To make risks clear, the following signal words and symbols are used for safety notes.



⚠ DANGER

Danger for persons!

Non-observance will inevitably cause irreversible injury or death.



⚠ WARNING

Dangers for persons!

Non-observance can lead to irreversible injury and even death.



⚠ CAUTION

Dangers for persons!

Non-observance can cause minor injuries.

CAUTION

Material damage!

Information about avoiding material damage.

1.1.2 Applicable documents

- General terms of business *
- Catalog data sheet of the purchased product *
- Assembly and operating manuals of the accessories *

The documents marked with an asterisk (*) can be downloaded on our homepage **schunk.com**

1.2 Warranty

If the product is used as intended, the warranty is valid for 24 months from the ex-works delivery date under the following conditions:

- Observe the specified maintenance and lubrication intervals
- Observe the ambient conditions and operating conditions

Parts touching the workpiece and wear parts are not included in the warranty.

1.3 Scope of delivery

The scope of delivery includes

- Plastic pneumatic linear unit KONEX H in the version ordered
- Assembly and Operating Manual
- Accessory pack

1.3.1 Accessory pack

Content of the accessory pack:

- 2x cylindrical pin DIN 6325 - Ø6m6x12
- 2x T-nut 29x12x4

ID.-No. of the accessory pack

Accessory pack for	ID number
KONEX H 50	5510624

1.4 Accessories

A wide range of accessories are available for this product
For information regarding which accessory articles can be used with the corresponding product variants, see catalog data sheet.

1.4.1 Sensors

Overview of the compatible sensors

Designation	Type
Magnetic switch	MMS

- Exact type designation of the compatible sensors see catalog.
- Information on handling sensors is available at schunk.com or from SCHUNK contact persons.

1.4.2 Seal kit

Content of the sealing kit:

- 1x complete piston
- 1x wiper ring 10.0x16.2x6
- 1x O-ring DIN 3771 16.0x1.50

ID.-No. of the seal kit

Seal kit for	ID number
KONEX H 50	0370781

Contents of the sealing kit, [Assembly drawing](#) [▶ 22].

2 Basic safety notes

2.1 Intended use

The product is exclusively designed for linear movement of useful loads into any desired position.

- The product may only be used within the scope of its technical data, [Technical data](#) [► 15].
- When implementing and operating components in safety-related parts of the control systems, the basic safety principles in accordance with DIN EN ISO 13849-2 apply. The proven safety principles in accordance with DIN EN ISO 13849-2 also apply to categories 1, 2, 3 and 4.
- The product is intended for installation in a machine/system. The applicable guidelines must be observed and complied with.
- The product is intended for industrial and industry-oriented use.
- Appropriate use of the product includes compliance with all instructions in this manual.

2.2 Not intended use

It is not intended use if the product is used, for example, as a pressing tool, stamping tool, lifting gear, guide for tools, cutting tool, clamping device or a drilling tool.

- Any utilization that exceeds or differs from the appropriate use is regarded as misuse.

2.3 Constructional changes

Implementation of structural changes

By conversions, changes, and reworking, e.g. additional threads, holes, or safety devices can impair the functioning or safety of the product or damage it.

- Structural changes should only be made with the written approval of SCHUNK.

2.4 Spare parts

Use of unauthorized spare parts

Using unauthorized spare parts can endanger personnel and damage the product or cause it to malfunction.

- Use only original spare parts or spares authorized by SCHUNK.

2.5 Ambient conditions and operating conditions

Required ambient conditions and operating conditions

Incorrect ambient and operating conditions can make the product unsafe, leading to the risk of serious injuries, considerable material damage and/or a significant reduction to the product's life span.

- Make sure that the product is used only in the context of its defined application parameters, [Technical data](#) [► 15].

2.6 Personnel qualification

Inadequate qualifications of the personnel

If the personnel working with the product is not sufficiently qualified, the result may be serious injuries and significant property damage.

- All work may only be performed by qualified personnel.
- Before working with the product, the personnel must have read and understood the complete assembly and operating manual.
- Observe the national safety regulations and rules and general safety instructions.

The following personal qualifications are necessary for the various activities related to the product:

Trained electrician	Due to their technical training, knowledge and experience, trained electricians are able to work on electrical systems, recognize and avoid possible dangers and know the relevant standards and regulations.
Qualified personnel	Due to its technical training, knowledge and experience, qualified personnel is able to perform the delegated tasks, recognize and avoid possible dangers and knows the relevant standards and regulations.
Instructed person	Instructed persons were instructed by the operator about the delegated tasks and possible dangers due to improper behaviour.
Service personnel of the manufacturer	Due to its technical training, knowledge and experience, service personnel of the manufacturer is able to perform the delegated tasks and to recognize and avoid possible dangers.

2.7 Personal protective equipment

Use of personal protective equipment

Personal protective equipment serves to protect staff against danger which may interfere with their health or safety at work.

- When working on and with the product, observe the occupational health and safety regulations and wear the required personal protective equipment.
- Observe the valid safety and accident prevention regulations.
- Wear protective gloves to guard against sharp edges and corners or rough surfaces.
- Wear heat-resistant protective gloves when handling hot surfaces.
- Wear protective gloves and safety goggles when handling hazardous substances.
- Wear close-fitting protective clothing and also wear long hair in a hairnet when dealing with moving components.

2.8 Notes on safe operation

Incorrect handling of the personnel

Incorrect handling and assembly may impair the product's safety and cause serious injuries and considerable material damage.

- Avoid any manner of working that may interfere with the function and operational safety of the product.
- Use the product as intended.
- Observe the safety notes and assembly instructions.
- Do not expose the product to any corrosive media. This does not apply to products that are designed for special environments.
- Eliminate any malfunction immediately.
- Observe the care and maintenance instructions.
- Observe the current safety, accident prevention and environmental protection regulations regarding the product's application field.

2.9 Transport

Handling during transport

Incorrect handling during transport may impair the product's safety and cause serious injuries and considerable material damage.

- When handling heavy weights, use lifting equipment to lift the product and transport it by appropriate means.
- Secure the product against falling during transportation and handling.
- Stand clear of suspended loads.

2.10 Malfunctions

Behavior in case of malfunctions

- Immediately remove the product from operation and report the malfunction to the responsible departments/persons.
- Order appropriately trained personnel to rectify the malfunction.
- Do not recommission the product until the malfunction has been rectified.
- Test the product after a malfunction to establish whether it still functions properly and no increased risks have arisen.

2.11 Disposal

Handling of disposal

The incorrect handling of disposal may impair the product's safety and cause serious injuries as well as considerable material and environmental harm.

- Follow local regulations on dispatching product components for recycling or proper disposal.

2.12 Fundamental dangers

General

- Observe safety distances.
- Never deactivate safety devices.
- Before commissioning the product, take appropriate protective measures to secure the danger zone.
- Disconnect power sources before installation, modification, maintenance, or calibration. Ensure that no residual energy remains in the system.
- If the energy supply is connected, do not move any parts by hand.
- Do not reach into the open mechanism or movement area of the product during operation.

2.12.1 Protection during handling and assembly

Incorrect handling and assembly

Incorrect handling and assembly may impair the product's safety and cause serious injuries and considerable material damage.

- Have all work carried out by appropriately qualified personnel.
- For all work, secure the product against accidental operation.
- Observe the relevant accident prevention rules.
- Use suitable assembly and transport equipment and take precautions to prevent jamming and crushing.

Incorrect lifting of loads

Falling loads may cause serious injuries and even death.

- Stand clear of suspended loads and do not step into their swiveling range.
- Never move loads without supervision.
- Do not leave suspended loads unattended.

2.12.2 Protection during commissioning and operation

Falling or violently ejected components

Falling and violently ejected components can cause serious injuries and even death.

- Take appropriate protective measures to secure the danger zone.
- Never step into the danger zone during operation.

2.12.3 Protection against dangerous movements

Unexpected movements

Residual energy in the system may cause serious injuries while working with the product.

- Switch off the energy supply, ensure that no residual energy remains and secure against inadvertent reactivation.
- Never rely solely on the response of the monitoring function to avert danger. Until the installed monitors become effective, it must be assumed that the drive movement is faulty, with its action being dependent on the control unit and the current operating condition of the drive. Perform maintenance work, modifications, and attachments outside the danger zone defined by the movement range.
- To avoid accidents and/or material damage, human access to the movement range of the machine must be restricted. Limit/prevent accidental access for people in this area due through technical safety measures. The protective cover and protective fence must be rigid enough to withstand the maximum possible movement energy. EMERGENCY STOP switches must be easily and quickly accessible. Before starting up the machine or automated system, check that the EMERGENCY STOP system is working. Prevent operation of the machine if this protective equipment does not function correctly.

2.12.4 Protection against electric shock

Possible electrostatic energy

Components or assembly groups may become electrostatically charged. When the electrostatic charge is touched, the discharge may trigger a shock reaction leading to injuries.

- The operator must ensure that all components and assembly groups are included in the local potential equalisation in accordance with the applicable regulations.
- While paying attention to the actual conditions of the working environment, the potential equalisation must be implemented by a specialist electrician according to the applicable regulations.
- The effectiveness of the potential equalisation must be verified by executing regular safety measurements.

2.13 Notes on particular risks



⚠ DANGER

Risk of fatal injury from suspended loads!

Falling loads can cause serious injuries and even death.

- Stand clear of suspended loads and do not step within their swiveling range.
- Never move loads without supervision.
- Do not leave suspended loads unattended.
- Wear suitable protective equipment.



⚠ WARNING

Risk of injury from objects falling and being ejected!

Falling and ejected objects during operation can lead to serious injury or death.

- Take appropriate protective measures to secure the danger zone.



⚠ WARNING

Risk of injury due to unexpected movements!

If the power supply is switched on or residual energy remains in the system, components can move unexpectedly and cause serious injuries.

- Before starting any work on the product: Switch off the power supply and secure against restarting.
- Make sure, that no residual energy remains in the system.



⚠ WARNING

Risk of injury from sharp edges and corners!

Sharp edges and corners can cause cuts.

- Use suitable protective equipment.

3 Technical data

Size	KONEX H 50
Piston force [N]	250.0
Stroke [N]	60.0
Noise emission [dB(A)]	≤ 70
Weight [kg]	0.45
IP rating	42
Nominal working pressure [bar]	6.0
Max. pressure [bar]	6.5
Ambient temperature [°C]	
Min. ambient temperature [°C]	+ 5
Max. ambient temperature [°C]	+ 60

More technical data is included in the catalog data sheet.
Whichever is the latest version.

4 Assembly

4.1 Connections

4.1.1 Mechanical connection

Evenness of the mounting surface

The values apply to the whole mounting surface to which the product is mounted.

Requirements for evenness of the mounting surface (Dimensions in mm)

Edge length	Permissible unevenness
< 100	< 0.02
> 100	< 0.05

Assembly of the adapter plates

Adapter plates can be fastened to the lifting plate (3) from below or above. Appropriate internal threads or through-holes are provided for this purpose in the lifting plate.

Use the cylindrical pins from the accessory pack for centering.

Assembly of the snap connectors

The snap connectors can be snapped onto the lifting plate or bottom cover.

They are removed with the supplied removal key.

4.1.2 Pneumatic connection

CAUTION

Damage to the gripper is possible!

If the maximum permissible finger weight or the permissible mass moment of inertia of the fingers is exceeded, the gripper can be damaged.

- A jaw movement always has to be without jerks and bounce.
- You must therefore implement sufficient reduction and/or damping.
- Observe the diagrams and information in the catalog data sheet.

NOTE

- Observe the requirements for the compressed air supply, [Technical data](#) [▶ 15].
- In case of compressed air loss (cutting off the energy line), the components lose their dynamic effects and do not remain in a secure position. However, the use of a SDV-P pressure maintenance valve is recommended in this case in order to maintain the dynamic effect for some time. Product variants are also offered with mechanical gripping force via springs, which also ensure a minimum clamping force in the event of a pressure drop.

The air connections for the stroke movement are arranged on the side of the stroke unit.

Connection	Function
A	Extend stroke unit
B	Retract stroke unit

Further information on the hose-free direct connection contains the catalog data sheet.

4.2 Mounting the sensor

NOTE

Observe the assembly and operating manual of the sensor for mounting and connecting.

The product is equipped for the use of sensors.

- For the exact type designations of suitable sensors, please see the catalog data sheet.
- For technical data for the suitable sensors, see Assembly and Operating Manual and catalog data sheet.
 - The Assembly and Operating Manual and catalog data sheet are included in the scope of delivery for the sensors and are available at schunk.com.
- Information on handling sensors is available at schunk.com or from SCHUNK contact persons.

4.2.1 MMS 30 magnetic switch

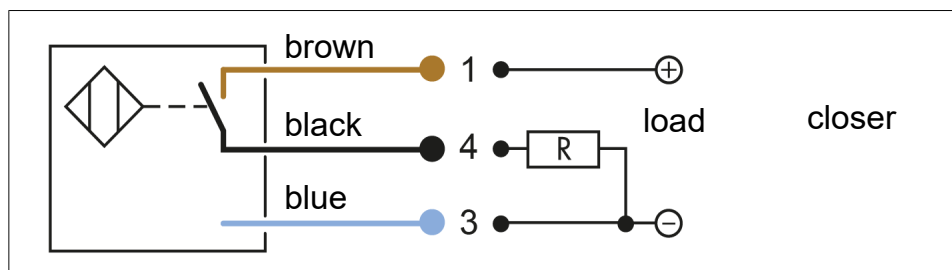
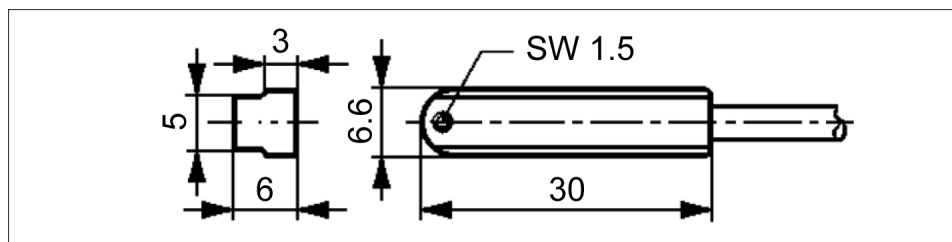

CAUTION

Risk of damage to the sensor during the assembly.

Observe a maximum tightening torque of 0.2 Nm for the set-screws.

NOTE

Ferromagnetic material changes the switching positions of the sensor. For example: Adapter plate made of ordinary steel.

At ferromagnetic adapter plates:

- First mount the product on the adapter plate.
 - Then set the position of the magnetic switch.
-

Assembly and adjustment of the magnetic switches**Linear unit "extended"**

- Set the linear unit to "extended" position.
- Push magnetic switch 1 from above into the T-slot intended for this purpose with the cable downwards until it switches.
- Mount the magnetic switch by tightening the set-screw.
- Retract and extend the lifting plate to test the function.

Linear unit "retracted"

- Set the linear unit to "extended" position.
- Push magnetic switch 2 from above into the T-slot intended for this purpose with the cable downwards until it switches.
- Set the linear unit to "retracted" position.
- Push magnetic switch 2 downwards into the T-slot. The magnetic switch must pass two switching points.
- Push magnetic switch 2 back again slowly until it switches.
- Mount magnetic switch 2 in this position by tightening the set-screw.
- Retract and extend the lifting plate to test the function.

5 Maintenance

5.1 Notes

Original spare parts

Use only original spare parts of SCHUNK when replacing spare and wear parts.

5.2 Maintenance and lubrication intervals

CAUTION

Material damage due to hardening lubricants!

Lubricants harden more quickly at temperatures above 60°C, leading to possible product damage.

- Reduce the lubricant intervals accordingly.

Size	50
Interval [Mio. cycles]	2

5.3 Lubricants/Lubrication points (basic lubrication)

SCHUNK recommends the lubricants listed.

During maintenance, treat all greased areas with lubricant. Thinly apply lubricant with a lint-free cloth.

Lubricant point	Lubricant
Sliding surfaces	microGLEIT GSV 790
All seals	Sealgood 1
Bore hole at the piston	Sealgood 1

5.4 Disassembly of the module

Position of the item numbers [Assembly drawing](#) [▶ 22]



⚠ WARNING

Risk of injury due to unexpected movements!

If the power supply is switched on or residual energy remains in the system, components can move unexpectedly and cause serious injuries.

- Before starting any work on the product: Switch off the power supply and secure against restarting.
- Make sure, that no residual energy remains in the system.



⚠ WARNING

Positions 4, 5 and 6 should not be loosened from the lifting plate, since otherwise the lifting plate would have to be readjusted.

- Remove the compressed air lines.
- Remove the screws (14) and detach the bottom cover (2).
- Loosen the screw (13) and remove the complete piston (16) from the piston rod (4).
- Pull out the lifting plate (3) with the piston rod (4), guide rods (5) and monitoring rod (6). **WARNING Positions 4, 5 and 6 should not be loosened from the lifting plate, since otherwise the lifting plate would have to be readjusted.**
- Remove all seals.

5.5 Servicing and assembling the module

Maintenance

- Clean all parts thoroughly and check for damage and wear.
- Treat all greased areas with lubricant.
[Lubricants/Lubrication points \(basic lubrication\)](#) [▶ 20]
- Oil or grease bare external steel parts.
- Replace all wear parts / seals.
 - Position of the wearing parts [Assembly drawing](#) [▶ 22]
 - Seal kit [Seal kit](#) [▶ 7]

Assembly

Assembly takes place in the opposite order to disassembly. Observe the following:

- Unless otherwise specified, secure all screws and nuts with Loctite no. 243 and tighten with the appropriate tightening torque.

5.6 Disposal

The plastics which had been used to manufacture this gripper can be recycled very easily.

You can send it back to SCHUNK

SCHUNK will take care of a proper disposal of the material.

5.7 Assembly drawing

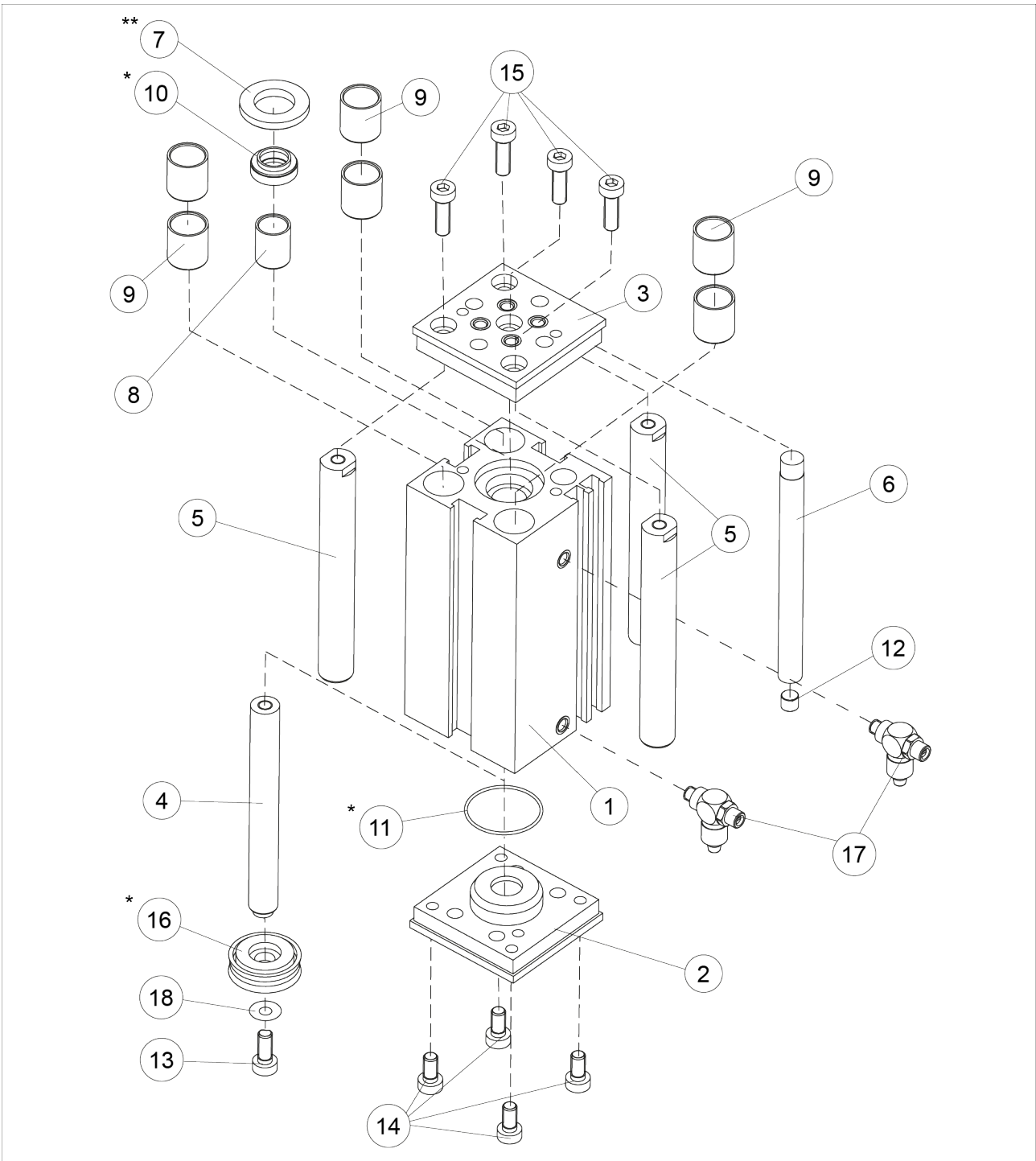

Assembly

- * Wearing part, replace during maintenance. Included in the seal kit. Seal kit can only be ordered completely.
- *** Glued, cannot be disassembled

6 Connection technique

6.1 Assembly / Disassembly of the Module

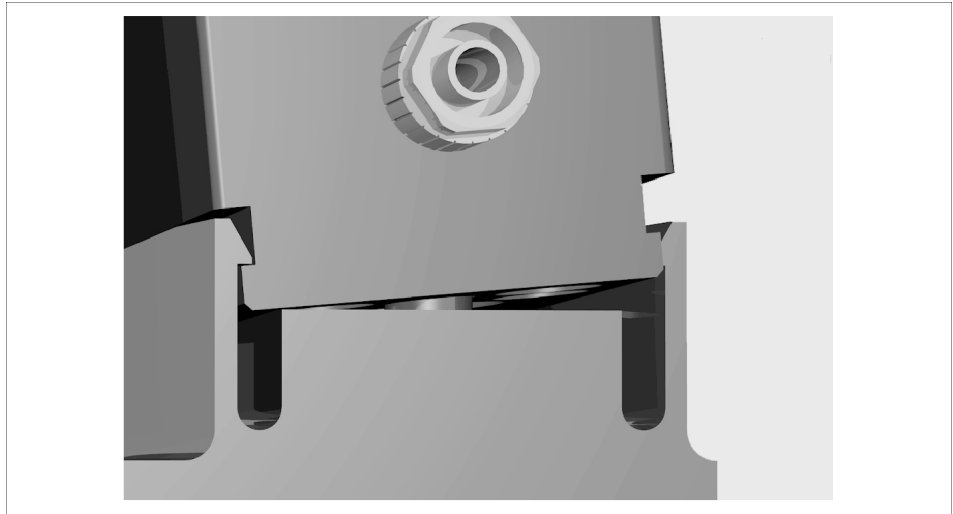

Every interface of the module is equipped with undercuts, which allow to snap in the connector. Therefore, the modules may be connected 90° offset.

6.2 Connection



The snap connector as a component, takes over the functions centering and fastening of the module.

For connection, the components are jammed, until the snap connector snaps into the undercut.

6.3 Loosen the connection in a „one second“- cycle time

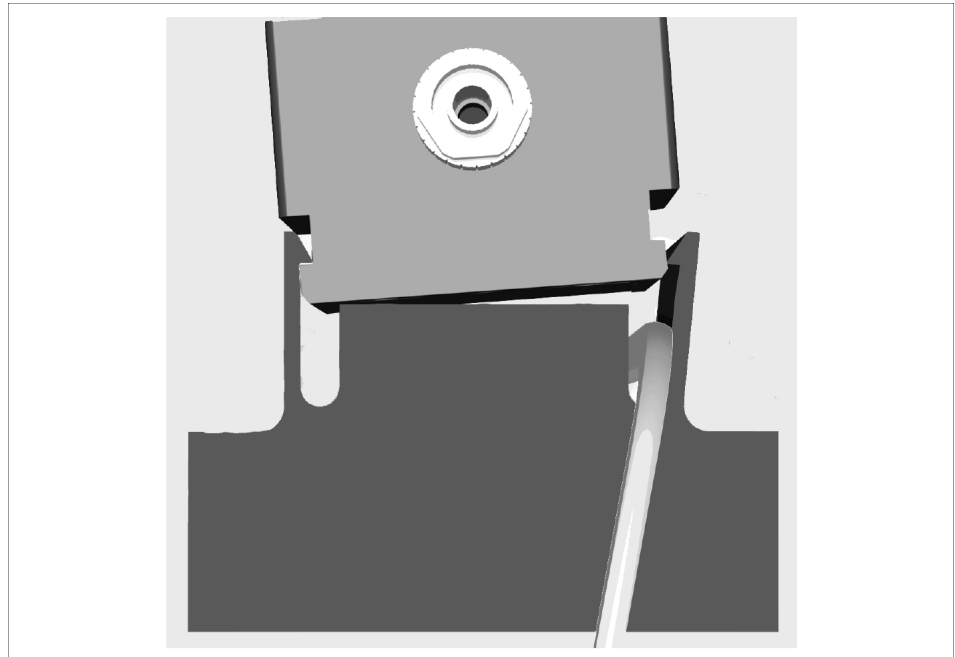

For disassembling you do not have to cope with damaged or jammed screws.

Just use the tool which is adjusted to the rate of expansion of the snapconnector and that is included in the delivery of every module.

Insert the key into the provided groove of the snap connector and turn the key by 90° in order to loosen the snap connector.

7.1 Annex to Declaration of Incorporation

according 2006/42/EG, Annex II, No. 1 B

1. Description of the essential health and safety requirements pursuant to 2006/42/EC, Annex I that are applicable and that have been fulfilled with:

Product designation	Plastic pneumatic linear unit
Type designation	KONEX H
ID number	0305350

To be provided by the System Integrator for the overall machine	↓
Fulfilled for the scope of the partly completed machine	↓
Not relevant	↓

1.1	Essential Requirements			
1.1.1	Definitions		X	
1.1.2	Principles of safety integration		X	
1.1.3	Materials and products		X	
1.1.4	Lighting		X	
1.1.5	Design of machinery to facilitate its handling		X	
1.1.6	Ergonomics		X	
1.1.7	Operating positions			X
1.1.8	Seating			X

1.2	Control Systems			
1.2.1	Safety and reliability of control systems		X	
1.2.2	Control devices		X	
1.2.3	Starting		X	
1.2.4	Stopping		X	
1.2.4.1	Normal stop		X	
1.2.4.2	Operational stop		X	
1.2.4.3	Emergency stop		X	
1.2.4.4	Assembly of machinery		X	
1.2.5	Selection of control or operating modes		X	
1.2.6	Failure of the power supply			X

1.3	Protection against mechanical hazards			
1.3.1	Risk of loss of stability			X
1.3.2	Risk of break-up during operation			X
1.3.3	Risks due to falling or ejected objects			X
1.3.4	Risks due to surfaces, edges or angles		X	
1.3.5	Risks related to combined machinery			X
1.3.6	Risks related to variations in operating conditions			X

1.3	Protection against mechanical hazards			
1.3.7	Risks related to moving parts		X	
1.3.8	Choice of protection against risks arising from moving parts			X
1.3.8.1	Moving transmission parts		X	
1.3.8.2	Moving parts involved in the process			X
1.3.9	Risks of uncontrolled movements			X
1.4	Required characteristics of guards and protective devices			
1.4.1	General requirements			X
1.4.2	Special requirements for guards			X
1.4.2.1	Fixed guards			X
1.4.2.2	Interlocking movable guards			X
1.4.2.3	Adjustable guards restricting access			X
1.4.3	Special requirements for protective devices			X
1.5	Risks due to other hazards			
1.5.1	Electricity supply		X	
1.5.2	Static electricity		X	
1.5.3	Energy supply other than electricity		X	
1.5.4	Errors of fitting		X	
1.5.5	Extreme temperatures			X
1.5.6	Fire			X
1.5.7	Explosion			X
1.5.8	Noise			X
1.5.9	Vibrations			X
1.5.10	Radiation	X		
1.5.11	External radiation	X		
1.5.12	Laser radiation	X		
1.5.13	Emissions of hazardous materials and substances			X
1.5.14	Risk of being trapped in a machine	X		
1.5.15	Risk of slipping, tripping or falling	X		
1.5.16	Lightning			X
1.6	Maintenance			
1.6.1	Machinery maintenance		X	
1.6.2	Access to operating positions and servicing points		X	
1.6.3	Isolation of energy sources		X	
1.6.4	Operator intervention		X	
1.6.5	Cleaning of internal parts		X	

Translation of original declaration of incorporation

1.7	Information			
1.7.1	Information and warnings on the machinery		X	
1.7.1.1	Information and information devices		X	
1.7.1.2	Warning devices		X	
1.7.2	Warning of residual risks		X	
1.7.3	Marking of machinery	X		
1.7.4	Instructions	X		
1.7.4.1	General principles for the drafting of instructions	X		
1.7.4.2	Contents of the instructions	X		
1.7.4.3	Sales literature	X		
	The classification from Annex 1 is to be supplemented from here forward.			
2	Supplementary essential health and safety requirements for certain categories of machinery			X
2.1	Foodstuffs machinery and machinery for cosmetics or pharmaceutical products			X
2.2	Portable hand-held and/or guided machinery			X
2.2.1	Portable fixing and other impact machinery			X
2.3	Machinery for working wood and material with similar physical characteristics			X
3	Supplementary essential health and safety requirements to offset hazards due to the mobility of machinery		X	
4	Supplementary essential health and safety requirements to offset hazards due to lifting operations		X	
5	Supplementary essential health and safety requirements for machinery intended for underground work			X
6	Supplementary essential health and safety requirements for machinery presenting particular hazards due to the lifting of persons		X	