



Assembly and Operating Manual

EGN

2-finger parallel gripper

Translation of Original Operating
Manual

Hand in hand for tomorrow

Imprint

Copyright:

This manual is protected by copyright. The author is SCHUNK SE & Co. KG.
All rights reserved.

Technical changes:

We reserve the right to make alterations for the purpose of technical improvement.

Document number: 389056

Version: 16.00 | 25/11/2024 | en

Dear Customer,

Thank you for trusting our products and our family-owned company, the leading technology supplier of robots and production machines.

Our team is always available to answer any questions on this product and other solutions. Ask us questions and challenge us. We will find a solution!

Best regards,

Your SCHUNK team

Customer Management

Tel. +49-7133-103-2503

Fax +49-7133-103-2189

cmg@de.schunk.com



Please read the operating manual in full and keep it close to the product.

Table of Contents

1	General	5
1.1	About this manual.....	5
1.1.1	Presentation of Warning Labels	5
1.1.2	Applicable documents	6
1.2	Sizes.....	6
1.3	Variants	6
1.4	Warranty	6
1.5	Scope of delivery.....	6
1.6	Accessories	7
2	Basic safety notes	8
2.1	Intended use.....	8
2.2	Constructional changes.....	8
2.3	Spare parts	8
2.4	Gripper fingers	9
2.5	Ambient conditions and operating conditions	9
2.6	Personnel qualification	9
2.7	Personal protective equipment	10
2.8	Notes on safe operation.....	11
2.9	Transport.....	11
2.10	Malfunctions.....	11
2.11	Disposal	12
2.12	Fundamental dangers	12
2.12.1	Protection during handling and assembly	12
2.12.2	Protection during commissioning and operation	13
2.12.3	Protection against dangerous movements	13
2.12.4	Protection against electric shock.....	14
2.12.5	Protection against magnetic and electromagnetic fields	15
2.13	Notes on particular risks	16
3	Technical data	18
3.1	Name plate	18
3.2	Basic data	19
3.3	Technical data for the integrated resolver.....	20
3.4	Technical data for the integrated motor	21
3.5	SCHUNK power and sensor cable	22

4 Design and description	23
4.1 Design	23
4.2 Description	24
4.3 Functional principle.....	24
5 Assembly.....	25
5.1 Assembling and connecting.....	25
5.2 Connections	27
5.2.1 Mechanical connection.....	27
5.2.2 Electrical connection to the ECM controller.....	29
5.3 Connecting the ground cable (functional ground).....	35
5.4 Air purge connection for dust-tight (SD) variant.....	36
6 Start-up and system integration via ECM controller.....	37
7 Troubleshooting.....	38
7.1 Behavior in case of product malfunctions	38
7.1.1 Product does not move.....	38
7.1.2 Gripping force gets weaker.....	38
7.1.3 Product does not execute a complete stroke.....	38
7.1.4 Product opens or closes jerkily	38
7.1.5 Motor rotates but does not move gripper.....	38
7.1.6 The module's motor is not turning.....	38
7.2 Behavior in event of malfunctions on the ECM controller	39
8 Maintenance	40
8.1 Maintenance intervals.....	40
8.2 Grease/greasing areas	40
8.3 Maintaining gripper without disassembling	41
8.4 Disassembly and assembling	41
8.5 Disassembling and assembling dust-proof variant	42
9 Translation of the original declaration of incorporation	44
10 UKCA declaration of incorporation	45
11 Information on the RoHS Directive, REACH Regulation and Substances of Very High Concern (SVHC)	46

1 General

1.1 About this manual

This manual contains important information for a safe and appropriate use of the product.

This manual is an integral part of the product and must be kept accessible for the personnel at all times.

Before starting work, the personnel must have read and understood this operating manual. Prerequisite for safe working is the observance of all safety instructions in this manual.

In addition to these instructions, the documents listed under ▶ 1.1.2 [6] are applicable.

NOTE: The illustrations in this manual are intended to provide a basic understanding and may deviate from the actual version.

1.1.1 Presentation of Warning Labels

To make risks clear, the following signal words and symbols are used for safety notes.



⚠ DANGER

Dangers for persons!

Non-observance will inevitably cause irreversible injury or death.



⚠ WARNING

Dangers for persons!

Non-observance can lead to irreversible injury and even death.



⚠ CAUTION

Dangers for persons!

Non-observance can cause minor injuries.

CAUTION

Material damage!

Information about avoiding material damage.

1.1.2 Applicable documents

- General terms of business *
- Catalog data sheet of the purchased product *
- Assembly and operating manuals of the accessories *
- "SCHUNK Drive Protocol (SDP)" software manual *
- "SCHUNK Motion Protocol (SMP)" software manual *
- Wiring diagram *

The documents labeled with an asterisk (*) can be downloaded from schunk.com/downloads.

1.2 Sizes

This operating manual applies to the following sizes:

- EGN 80
- EGN 100
- EGN 160

1.3 Variants

This operating manual applies to the following variations:

- EGN with hybrid cable
- EGN-S with Y-plug
- EGN Dust-tight version (SD)
- EGN-S Dust-tight version (SD)

1.4 Warranty

If the product is used as intended, the warranty is valid for 24 months from the ex-works delivery date under the following conditions:

- Observe the maximum service life. ▶ 3 [18]
- Observe the ambient conditions and operating conditions, ▶ 2.5 [9]
- Observe the specified maintenance and lubrication intervals, ▶ 8 [40]

Parts touching the workpiece and wear parts are not included in the warranty.

1.5 Scope of delivery

The scope of delivery includes

- 2-finger parallel gripper EGN in the version ordered
- Safety information (product-specific instructions available online)
- Accessory pack

1.6 Accessories

The following accessories, which must be ordered separately, are required for the product:

- Controller ECM
- Power and sensor cables for variant EZN-S

Contents of the DVD enclosed with the ECM controller:

- "Motion Tool Schunk (MTS)" configuration and commissioning tool
- EEPROM files for the ECM controller
- Assembly and Operating Manual
- FB20 function module for Siemens S7 300/400 for controlling SCHUNK products
- "Schunk Motion Tool (MTS)" software manual

A wide range of accessories are available for this product

For information regarding which accessory articles can be used with the corresponding product variants, see catalog data sheet.

2 Basic safety notes

2.1 Intended use

The product is designed exclusively for gripping and temporarily holding workpieces or objects.

- The product may only be used within the scope of its technical data, ▶ 3 [18].
- The product is intended for installation in a machine/ automated system. The applicable guidelines for the machine/ automated system must be observed and complied with.
- The product is intended for industrial and industry-oriented use. Its use outside enclosed spaces is only permitted if suitable protective measures are taken against outdoor exposure. The product is not suitable for use in salty air.
- The product can be used within the permissible load limits and technical data for holding workpieces during simple machining operations, but is not a clamping device according to EN 1550:1997+A1:2008.
- Appropriate use of the product includes compliance with all instructions in this manual.
- Any utilization that exceeds or differs from the appropriate use is regarded as misuse.

2.2 Constructional changes

Implementation of structural changes

Modifications, changes or reworking, e.g. additional threads, holes, or safety devices, can damage the product or impair its functionality or safety.

- Structural changes should only be made with the written approval of SCHUNK.

2.3 Spare parts

Use of unauthorized spare parts

Using unauthorized spare parts can endanger personnel and damage the product or cause it to malfunction.

- Use only original spare parts or spares authorized by SCHUNK.

2.4 Gripper fingers

Requirements of gripper fingers

Accumulated energy can make the product unsafe and risk the danger of serious injuries and considerable material damage.

- Execute the gripper fingers in such a way that the product reaches either the "open" or "closed" position in a de-energized state.
- Only change gripper fingers if no residual energy can be released.
- Make sure that the product and the top jaws are a sufficient size for the application.

2.5 Ambient conditions and operating conditions

Required ambient conditions and operating conditions

Incorrect ambient and operating conditions can make the product unsafe, leading to the risk of serious injuries, considerable material damage and/or a significant reduction to the product's life span.

- Make sure that the product is used only in the context of its defined application parameters, ▶ 3 [📄 18].

2.6 Personnel qualification

Inadequate qualifications of the personnel

If the personnel working with the product is not sufficiently qualified, the result may be serious injuries and significant property damage.

- All work may only be performed by qualified personnel.
- Before working with the product, the personnel must have read and understood the complete assembly and operating manual.
- Observe the national safety regulations and rules and general safety instructions.

The following personal qualifications are necessary for the various activities related to the product:

Trained electrician	Due to their technical training, knowledge and experience, trained electricians are able to work on electrical systems, recognize and avoid possible dangers and know the relevant standards and regulations.
Qualified personnel	Due to its technical training, knowledge and experience, qualified personnel is able to perform the delegated tasks, recognize and avoid possible dangers and knows the relevant standards and regulations.
Instructed person	Instructed persons were instructed by the operator about the delegated tasks and possible dangers due to improper behaviour.
Service personnel of the manufacturer	Due to its technical training, knowledge and experience, service personnel of the manufacturer is able to perform the delegated tasks and to recognize and avoid possible dangers.

2.7 Personal protective equipment

Use of personal protective equipment

Personal protective equipment serves to protect staff against danger which may interfere with their health or safety at work.

- When working on and with the product, observe the occupational health and safety regulations and wear the required personal protective equipment.
- Observe the valid safety and accident prevention regulations.
- Wear protective gloves to guard against sharp edges and corners or rough surfaces.
- Wear heat-resistant protective gloves when handling hot surfaces.
- Wear protective gloves and safety goggles when handling hazardous substances.
- Wear close-fitting protective clothing and also wear long hair in a hairnet when dealing with moving components.

2.8 Notes on safe operation

Incorrect handling of the personnel

Incorrect handling and assembly may impair the product's safety and cause serious injuries and considerable material damage.

- Avoid any manner of working that may interfere with the function and operational safety of the product.
- Use the product as intended.
- Observe the safety notes and assembly instructions.
- Do not expose the product to any corrosive media. This does not apply to products that are designed for special environments.
- Eliminate any malfunction immediately.
- Observe the care and maintenance instructions.
- Observe the current safety, accident prevention and environmental protection regulations regarding the product's application field.

2.9 Transport

Handling during transport

Incorrect handling during transport may impair the product's safety and cause serious injuries and considerable material damage.

- When handling heavy weights, use lifting equipment to lift the product and transport it by appropriate means.
- Secure the product against falling during transportation and handling.
- Stand clear of suspended loads.

2.10 Malfunctions

Behavior in case of malfunctions

- Immediately remove the product from operation and report the malfunction to the responsible departments/persons.
- Order appropriately trained personnel to rectify the malfunction.
- Do not recommission the product until the malfunction has been rectified.
- Test the product after a malfunction to establish whether it still functions properly and no increased risks have arisen.

2.11 Disposal

Handling of disposal

The incorrect handling of disposal may impair the product's safety and cause serious injuries as well as considerable material and environmental harm.

- Follow local regulations on dispatching product components for recycling or proper disposal.

2.12 Fundamental dangers

General

- Observe safety distances.
- Never deactivate safety devices.
- Before commissioning the product, take appropriate protective measures to secure the danger zone.
- Disconnect power sources before installation, modification, maintenance, or calibration. Ensure that no residual energy remains in the system.
- If the energy supply is connected, do not move any parts by hand.
- Do not reach into the open mechanism or movement area of the product during operation.

2.12.1 Protection during handling and assembly

Incorrect handling and assembly

Incorrect handling and assembly may impair the product's safety and cause serious injuries and considerable material damage.

- Have all work carried out by appropriately qualified personnel.
- For all work, secure the product against accidental operation.
- Observe the relevant accident prevention rules.
- Use suitable assembly and transport equipment and take precautions to prevent jamming and crushing.

Incorrect lifting of loads

Falling loads may cause serious injuries and even death.

- Stand clear of suspended loads and do not step into their swiveling range.
- Never move loads without supervision.
- Do not leave suspended loads unattended.

2.12.2 Protection during commissioning and operation

Falling or violently ejected components

Falling and violently ejected components can cause serious injuries and even death.

- Take appropriate protective measures to secure the danger zone.
- Never step into the danger zone during operation.

2.12.3 Protection against dangerous movements

Unexpected movements

Residual energy in the system may cause serious injuries while working with the product.

- Switch off the energy supply, ensure that no residual energy remains and secure against inadvertent reactivation.
- The faulty actuation of connected drives may cause dangerous movements.
- Operating mistakes, faulty parameterization during commissioning or software errors may trigger dangerous movements.
- Never rely solely on the response of the monitoring function to avert danger. Until the installed monitors become effective, it must be assumed that the drive movement is faulty, with its action being dependent on the control unit and the current operating condition of the drive. Perform maintenance work, modifications, and attachments outside the danger zone defined by the movement range.
- To avoid accidents and/or material damage, human access to the movement range of the machine must be restricted. Limit/prevent accidental access for people in this area due through technical safety measures. The protective cover and protective fence must be rigid enough to withstand the maximum possible movement energy. EMERGENCY STOP switches must be easily and quickly accessible. Before starting up the machine or automated system, check that the EMERGENCY STOP system is working. Prevent operation of the machine if this protective equipment does not function correctly.

2.12.4 Protection against electric shock

Work on electrical equipment

Touching live parts may result in death.

- Work on the electrical equipment may only be carried out by qualified electricians in accordance with the electrical engineering regulations.
- Lay electrical cables properly, e. g. in a cable duct or a cable bridge. Observe standards.
- Before connecting or disconnecting electrical cables, switch off the power supply and check that the cables are free of voltage. Secure the power supply against being switched on again.
- Before switching on the product, check that the protective earth conductor is correctly attached to all electrical components according to the wiring diagram.
- Check whether covers and protective devices are fitted to prevent contact with live components.
- Do not touch the product's terminals when the power supply is switched on.

Possible electrostatic energy

Components or assembly groups may become electrostatically charged. When the electrostatic charge is touched, the discharge may trigger a shock reaction leading to injuries.

- The operator must ensure that all components and assembly groups are included in the local potential equalisation in accordance with the applicable regulations.
- While paying attention to the actual conditions of the working environment, the potential equalisation must be implemented by a specialist electrician according to the applicable regulations.
- The effectiveness of the potential equalisation must be verified by executing regular safety measurements.

2.12.5 Protection against magnetic and electromagnetic fields

Work in areas with magnetic and electromagnetic fields

Magnetic and electromagnetic fields can lead to serious injuries.

- Persons with pace-makers, metal implants, metal shards, or hearing aids require the consent of a physician before entering areas in which components of the electric drive and control systems are mounted, started up, and operated.
- Persons with pace-makers, metal implants, metal shards, or hearing aids require the consent of a physician before entering areas in which magnetic grippers or motor parts with permanent magnets are stored, repaired, or assembled.
- Do not operate high-frequency or radio devices in the proximity of electric components of the drive system and their feed lines.

If the use of such devices is necessary:

When starting up the electric drive and control system, check the machine or automated system for possible failures when such systems are used at different intervals and in different states of the control system. A special additional EMC test may be necessary if the system has a high risk potential.

2.13 Notes on particular risks



⚠ DANGER

Danger from electric voltage!

Touching live parts may result in death.

- Switch off the power supply before any assembly, adjustment or maintenance work and secure against being switched on again.
- Only qualified electricians may perform electrical installations.
- Check if de-energized, ground it and hot-wire.
- Cover live parts.



⚠ DANGER

Risk of fatal injury from suspended loads!

Falling loads can cause serious injuries and even death.

- Stand clear of suspended loads and do not step within their swiveling range.
- Never move loads without supervision.
- Do not leave suspended loads unattended.
- Wear suitable protective equipment.



⚠ WARNING

Risk of injury from objects falling and being ejected!

Falling and ejected objects during operation can lead to serious injury or death.

- Take appropriate protective measures to secure the danger zone.



⚠ WARNING

Risk of injury due to unexpected movements!

If the power supply is switched on or residual energy remains in the system, components can move unexpectedly and cause serious injuries.

- Before starting any work on the product: Switch off the power supply and secure against restarting.
- Make sure, that no residual energy remains in the system.



⚠ WARNING

Risk of injury from crushing and impacts!

Serious injury could occur during movement of the base jaw, due to breakage or loosening of the gripper fingers or if the workpiece is lost.

- Wear suitable protective equipment.
- Do not reach into the open mechanism or the movement area of the product.



⚠ WARNING

Risk of injury from sharp edges and corners!

Sharp edges and corners can cause cuts.

- Use suitable protective equipment.



⚠ WARNING

Risk of injury from objects falling in the event of an energy supply failure

In case of an energy supply failure, the gripping force decreases and a secure hold on the gripped workpiece cannot be guaranteed.

- Take suitable protective measures to secure the danger zone.

3 Technical data

3.1 Name plate

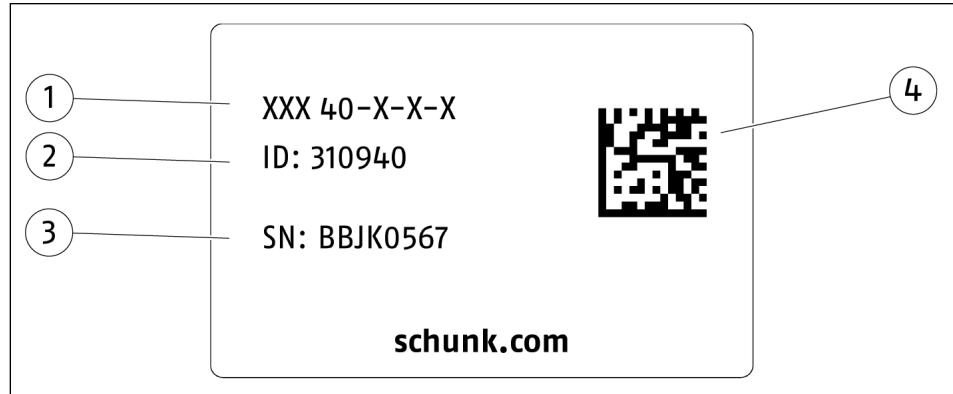

1 Product designation

2 ID

3 Serial number

4 Data matrix code

Scan code or enter serial number on the web and get all the product information: operating manuals, spare parts packages, software updates and much more.

For further information, visit [schunk.com/serialisierung](https://www.schunk.com/serialisierung)

A separate app may be required for scanning with a mobile phone.

3.2 Basic data

Designation	EGN		
	80	100	160
Mechanical operating data			
Weight [kg]	0.84	1.35	3
Noise emission [dB(A)]		≤ 70	
IP rating		41	
Ambient temperature [°C]			
Min.		+5	
Max.		+55	
Stroke per jaw [mm]	8	10	16
Min. adjustable gripping force [N]		≈ 170	
Max. gripping force [N]	400	720	1000
Opening time/closing time for a complete stroke [s]	0.35	0.35	0.5
Max. acceleration [mm/s ²] a		1500	
Max. permissible finger length [mm]	100	125	200
Repeatability [mm] in power mode (end position spread after 100 consecutive strokes)		±0.01	
Brake			
Brake		not present	
Electrical operating data			
Nominal voltage [VDC]		24	
Nominal power current [A]	1.0	1.8	2.6
Max. current [A]		4.0	
Designation	EGN		
	80	100	160
Mechanical operating data for dust-tight (SD) variant			
Weight [kg]	0.94	1.53	3.4
IP rating		64	
Pressure range for air purge [bar]		0.5 – 1.0	
Designation	EGN		
	80	100	160
Warranty duration [months]	24	24	24
Or maximum cycles [piece]	10,000,000	10,000,000	10,000,000

More technical data is included in the catalog data sheet.
Whichever is the latest version.

3.3 Technical data for the integrated resolver

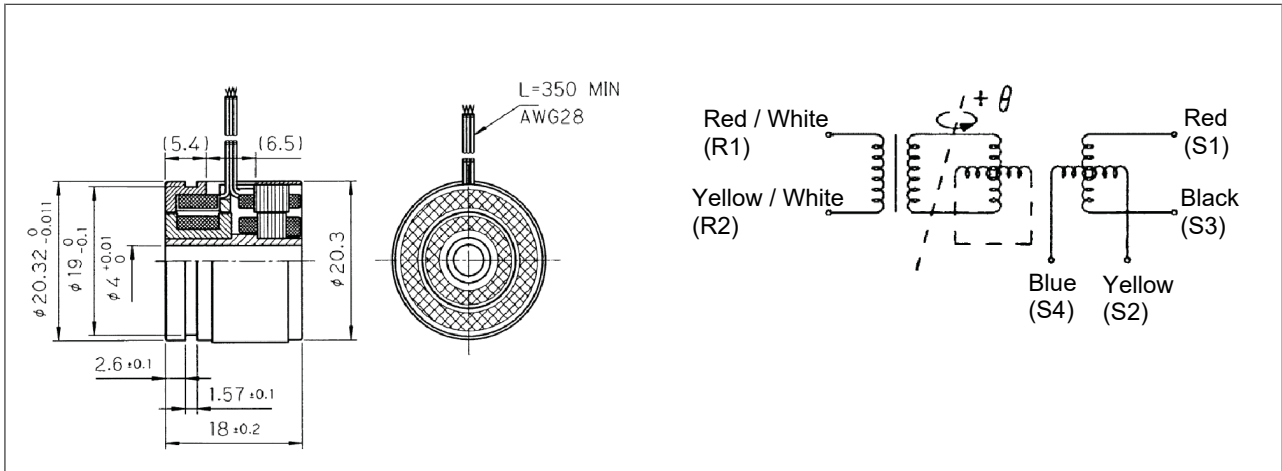

Dimension of resolver and schematic diagram

- Dimensions (mm)
- Dimensions without tolerances ± 0.4 mm
- Output equation
 - $ES1-S3 = KER1-R2 \cos \ominus$
 - $ES2-S4 = KER1-R2 \sin \ominus$
 - $+\ominus$: Rotor turns CCW from the attachment side

Characteristics	Specification:	Note
Function	1X – BRX	
Primary	Runner	
Transmission ratio	$0.5 \pm 5\%$	
Zero voltage	20 mV max.	
Input impedance Z_{RO}	$140 \Omega \pm 20\%$	
Output impedance Z_{SS}	$120 \Omega \pm 20\%$	
Electric strength	AC 500 Vms 1 min.	60Hz
Leakage resistance	100 m Ω min.	DC 500V
Weight	0.03 kg nom.	
Operating temperature	-50°C +155°C	

3.4 Technical data for the integrated motor

Designation	Constant	Indication of value
Clamping voltage [V]	U_{KL}	24
Rated torque [Nm]	M_n	0.41
Nominal power current [A]	I_n	▶ 3.2 [19]
Peak current [A]	I_{eff}	▶ 3.2 [19]
Torque constant [Nm/A]	K	0.069
Rated speed [rpm]	U_n	1700
Max. rotation speed [rpm]	U_{max}	2200
Max. frequency [Hz]	F_{max}	256.7
Power loss at M_n [W]	P_v	9
Motor constant [N/w]	K_m	0.1
Intermediate circuit voltage [V]	U_{zk}	24
Counter-voltage (phase-phase) [V]	Electromotive force	0.00642 at 1 rpm
Resistance (phase-phase) [Ω]	$R_{\pi 20}$	1.5
Inductivity (phase-phase) [mH]	L_{π}	1.4
Time constant [ms]	T_{ξ}	0.93
Number of pole pairs	N	7

Useful formula Finger stroke = $\tan(40^\circ) \times \text{motor angle}[\text{rad}]/\Phi$

Technical recommendation

Type	80	100	160
I [A]	1.0	1.8	2.6
Gripping force [N]	400	720	1000
Max. V [mm stroke/sec.]	80	80	80
Max. A [mm stroke/sec.]	3000	3000	3000

NOTE

- The tolerances of M, I, n may be up to $\pm 20\%$.
- All temperatures correspond to insulation class F.
- M_{max} is limited by the maximum current.

3.5 SCHUNK power and sensor cable

Cable type	Power	Transducer
Number of wires/cross-section	4 x 0.75 mm ² + 2 x 0.25 mm ²	8 x 0.25 mm ²
Max. voltage [V]	600	24
Shielded	yes	yes
Shield around individual wire strands	no	yes
Twisted	no	yes
Temperature application range [°C]	+5 to +55	+5 to +55
Max. cable length [m]	20	20
Max. conductor resistance		
0.25 mm ²	78 0hm/km	78 0hm/km
0.75 mm ²	26 0hm/km	-

Cable type	Power	Transducer
Cable track		
Bending radius [x times the cable diameter]		
once		3 x D
several times		7.5 x D
permanently (cable track)		10 x D

Cable type	Power	Transducer
Torsion		
Bending radius [x times the cable diameter]		
once		5 x D
several times		8.5 x D
permanently (torsion)		12 x D
Torsion range		±180 °/m

The catalog data sheet contains further information on the cable as well as a drawing of it.

4 Design and description

4.1 Design

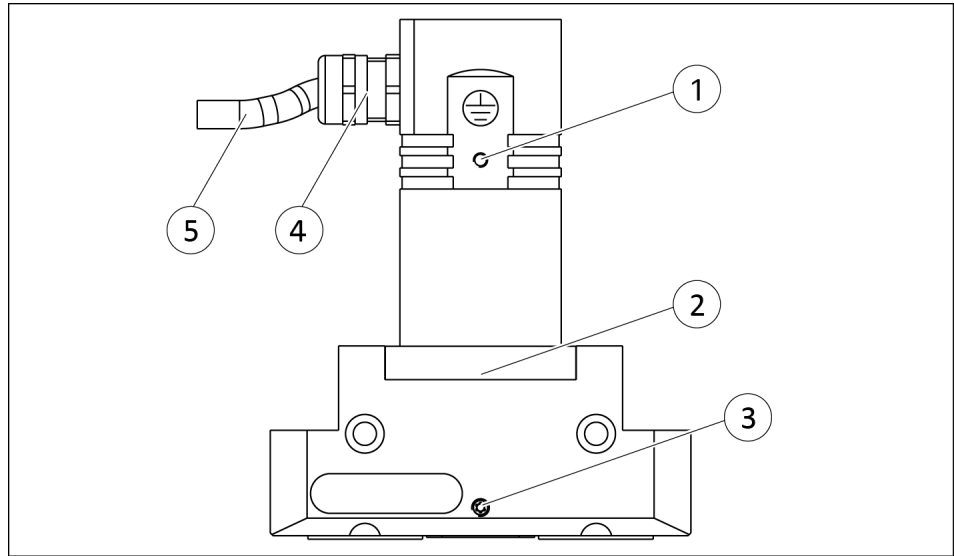

2-finger parallel gripper with hybrid cable

1	Ground connection	4	EMC fitting
2	Housing	5	Hybrid cable for connection to controller
3	Air purge connection		

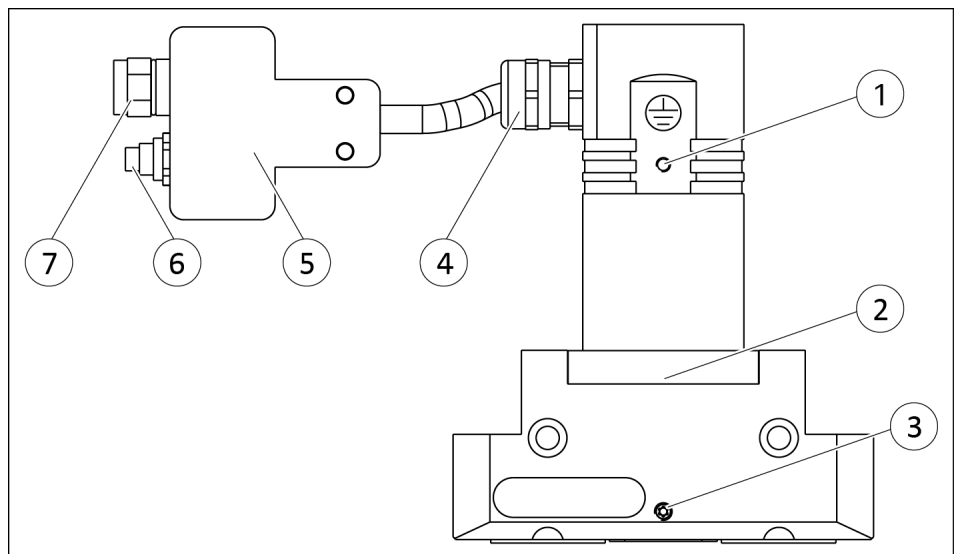

2-finger parallel gripper with Y-plug

1	Ground connection	5	Y-plug
2	Housing	6	Encoder connection
3	Air purge connection	7	Power connection
4	EMC fitting		

4.2 Description

The product is a servo-electric 2-finger parallel gripper with high gripping force and payloads due to multi-tooth guidance.

The product is controlled by an external controller. Optimal application utilization is achieved with the SCHUNK ECM controller.

4.3 Functional principle

All possible parameters are described in the document relating to the SCHUNK Drive Protocol, see *Drive Protocol* document.

5 Assembly

5.1 Assembling and connecting



⚠ DANGER

Risk of fatal injury due to electric current!

Touching live parts possess an immediate risk of fatal injury by electrocution.

- Prior to commencing work, restore the regulator to a de-energized state.
 - ⇒ Disconnect the logic and motor voltages.
- Wait until the intermediate circuit voltage has dropped to a residual voltage of less than 10 V.
 - ⇒ LED "UMOT" goes out.
 - ⇒ Check "supply voltage" between U_{Mot} and GND on the terminal strip.

CAUTION

Material damage due to mechanical forces!

If the cable, which is fixed to the product, or the plug is exposed to mechanical forces (e. g. turn or bend), this may lead to a cable break.

- Fasten the plug so to the product, that the plug is always in the quite same position to the gripper and is no subjected to mechanical stress.

NOTE

See Assembly and Operating Manual "ECM Controller" for instructions on the electrical connection of the product to the ECM controller.

Both variants

- Logic and motor voltage are disconnected from the controller.
 - The intermediate circuit voltage has dropped to a residual voltage of less than 10 V.
1. Check the flatness of the mounting surface, ▶ 5.2.1 [27].
 2. Screw the product to the machine/system, ▶ 5.2.1 [27].
 - ⇒ Use suitable connecting elements (adapter plates) if necessary.
 - ⇒ Observe the permissible depth of engagement.
 - ⇒ Observe the tightening torque for the mounting screws.

Variant with hybrid cable

3. Connect the ground cable between the product and the machine/system, ▶ 5.3 [📄 35].
- Connect the connection cable, ▶ 5.2.2 [📄 29].
 - ⇒ Encoder connection cable on the controller to the "Resolver" terminal strip.
 - ⇒ Power connection cable on the controller to the "Motor" terminal strip.

Variant with Y-plug

1. Plug encoder and power connection cables into the Y-plug and screw in.
2. Connect the connection cable, ▶ 5.2.2 [📄 29].
 - ⇒ Encoder connection cable on the controller to the "Resolver" terminal strip.
 - ⇒ Power connection cable on the controller to the "Motor" terminal strip.
3. Fasten the connection plug to the machine/system via the assembly bores.
 - ⇒ **IMPORTANT! The cable between gripper and Y-plug may not be subjected to any mechanical load.**

**Both variants
Variant dust-tight (SD)**

- Protect the power circuit of the controller, ▶ 5.2.2.3 [📄 33].
- Connect air purge connection, ▶ 5.4 [📄 36].

5.2 Connections

5.2.1 Mechanical connection

Evenness of the mounting surface

The values apply to the whole mounting surface to which the product is mounted.

Edge length	Permissible unevenness
< 100	< 0.02
> 100	< 0.05

Tab.: Requirements for evenness of the mounting surface (Dimensions in mm)

Choose the installation position so that connection cables are not damaged or cannot wrap around the product when swiveling.

Preconditions for installing the connection cables:

- The cables are without tensile and torsion loads. Use cable guide chains.
- The minimum bending radius (7.5 times the cable diameter) is complied with.

Assembly of the top jaws

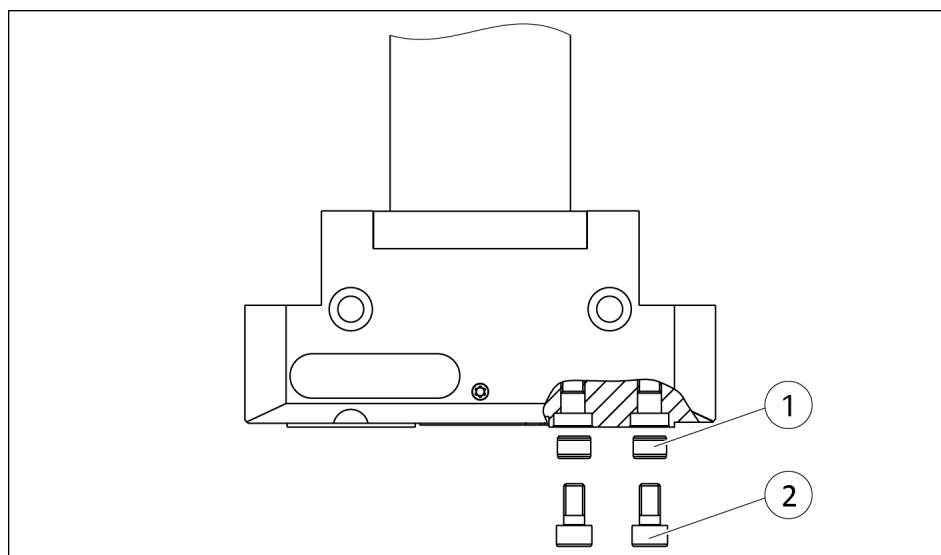

Assembly of the top jaws

Item	Mounting	EGN		
		80	100	160
1	Centering sleeve	Ø 8	Ø 10	Ø 12
2	Thread in the base jaws	M5	M6	M10
	Max. depth of engagement [mm]	10	13	17
	Mounting screws as per standard	DIN EN ISO 4762		

Tab.: Depth of engagement and tightening torque

Assembly of the product

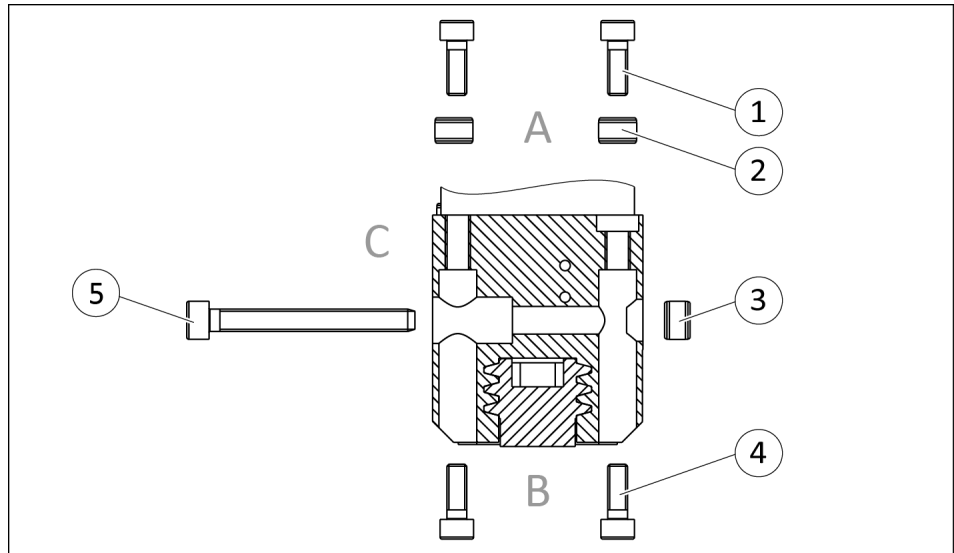

Assembly options

Item	Mounting	EGN		
		80	100	160

Side A

1	Mounting screws	M5	M6	M8
	Max. depth of engagement [mm]	15	41	20
	Mounting screws as per standard	DIN EN ISO 4762		
2	Centering sleeve	∅ 8	∅ 10	∅ 14

Side B

1	Bore hole for mounting screws	M4	M5	M6
2	Centering sleeve	∅ 8	∅ 10	∅ 14

Side C

1	Bore hole for mounting screws	M5	M6	M8
2	Centering sleeve	∅ 8	∅ 10	∅ 14

Tab.: Depth of engagement and tightening torque

5.2.2 Electrical connection to the ECM controller



⚠ DANGER

Danger from electric voltage!

Touching live parts can result in death.

- Switch off energy supply before carrying out all assembly, adjustment and maintenance work and secure against re-connection.
- Only allow qualified electricians to work on electrical automated systems.
- Disconnect the controller from the power supply. The intermediate circuit capacitors must be discharged. Wait for approx. 5 minutes for the capacitors to discharge.
- Ensure that there is no voltage, earth and short-circuit the system.
- Cover up live parts.

CAUTION

Risk of damage to the electronics!

A faulty connection can cause damage to the internal electronics.

- The supply network must be a network of type "PELV" for power and logic.
- Observe the PIN assignment of the connecting terminals.
- Make sure that all components are grounded correctly.

5.2.2.1 Pin allocation

Hybrid cable variant

Terminal	Wire color *	
SHD		Shield (shield connection via cable clamp below the motor terminal strip)
U	Black	Motor phases
V	Red	
W	White	

(*) Wire color of the supplied SCHUNK cable, otherwise according to customer specifications

Tab.: Pin allocation terminal strip motor at drive regulator ECM

Phoenix terminal	Wire color (*)	Resolver signals
1 Sin+	Yellow	+ Sin

Variant with Y-plug

Phoenix terminal	Wire color (*)	Resolver signals	
2	Sin-	Blue	- Sin
3	Cos+	Black	+ Cos
4	Cos-	Red	- Cos
5	Osz+	White/Red	+ Ref
6	GND	White/Yellow	- Ref

(*) Wire color of the supplied SCHUNK cable, otherwise according to customer specifications

Tab.: Pin allocation terminal strip resolver at drive regulator ECM

Connection	Plug connector EGN-S
Encoder connection	M12-A connector, 8-pin
Power connection	Connection plug M17, 7-pin

Tab.: used plug connector

The product is supplied with pre-assembled adapter cables in lengths of 5, 10, 15 or 20 m, which must be ordered separately, ▶ 1.6 [7].

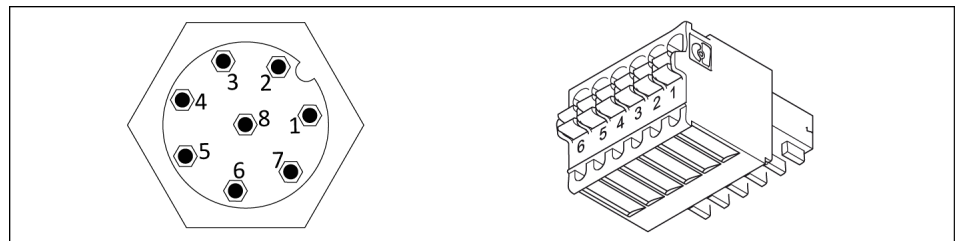

M12 connector and Phoenix terminal

M12-cable socket	Wire color (*)	Phoenix terminal	
1	Sin-	Green	2
2	Sin+	Yellow	1
3	Cos-	Brown	4
4	Cos+	White	3
5	Inner shield and on housing		
6	unassigned		
7	GND	Grey	6
8	Osz+	Pink	5

(*) Wire color of the supplied SCHUNK cable, otherwise according to customer specifications

Tab.: Pin allocation M12-connector to Phoenix terminal

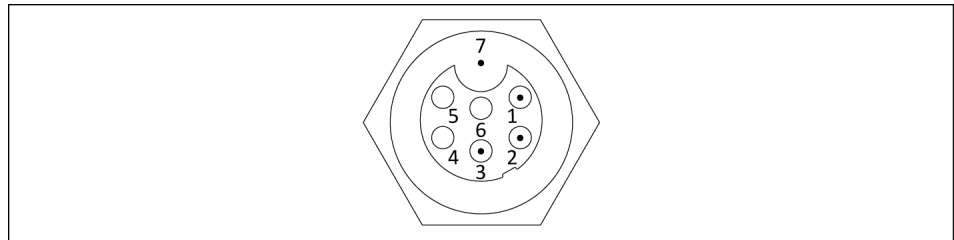

Connection plug M17

Connection plug M17	Wire color (*)	Motor terminal strip	
1	Motor phase U	Black	U
2	Motor phase V	Red	V
3	Motor phase W	White	W
4	unassigned		
5	unassigned		
6	unassigned		
7	Outer shield		

(*) Wire color of the supplied SCHUNK cable, otherwise according to customer specifications

Tab.: Pin allocation connection plug M17 on stranded wires

5.2.2.2 Wiring diagram

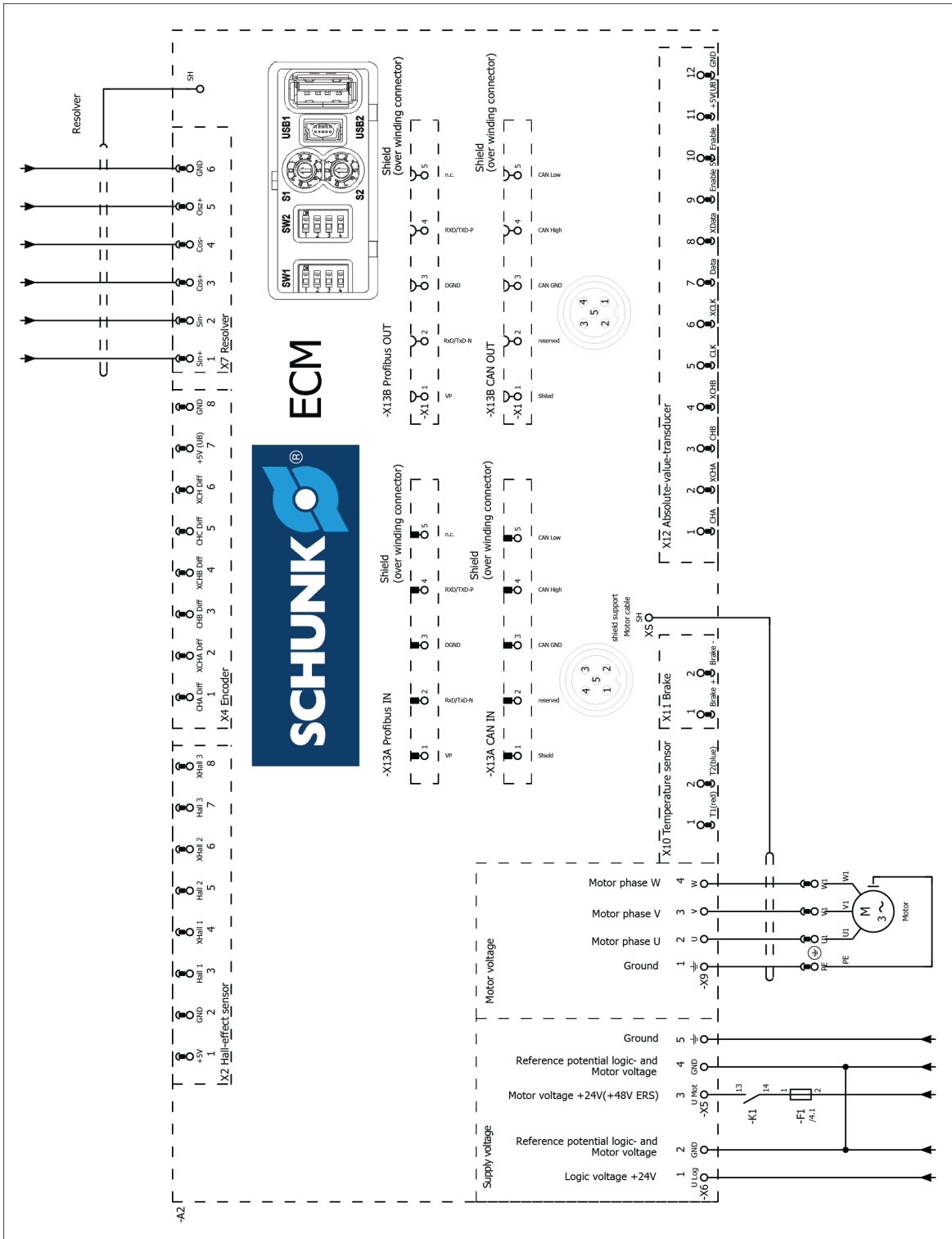

Wiring diagram

5.2.2.3 External protection

CAUTION

Risk of damage to the controller!

If the power circuit of the controller is too high or not protected, the controller may be damaged.

- Protect the power circuit of the ECM controller with maximum 6 A.

The power circuit of the ECM controller must be protected by the customer.

The following three alternatives for ensuring external fuse protection are possible:

- Protection by means of an external, fixed fuse.
- Protection via current limiting of the supplying power supply unit
- Protection via a motor protection switch

Protection by means of an external, fixed fuse.

The fuse must comply with the technical data given in the following table.

The following fuse manufactured by ESKA is recommended:

Manufacturer's code	520.525
Symbol	ZCS-6.3A
Type	safety fuse
Characteristics	fast-acting
Type:	ceramic, miniature fuse
Switching capability [kA]	1.5
Rated current [A]	6.3
Rated voltage [VAC]	250
Tripping characteristic	2.1 I _n : max. 30 Min. 2.75 I _n : min. 10 ms, 2.75 I _n : max. 2 s, 4 I _n : min. 3 ms, 4 I _n : max. 300 ms, 10 I _n : max. 20 ms
Maximum voltage drop [mV]	200

Protection via current limiting of the supplying power supply unit

The power supply unit must comply with the technical data given in the following table.

The following power supply unit manufactured by PULS is recommended:

Manufacturer's code	DIMENSION QS5.241
Type	Clocked
Connections	Spring terminal
Number of outputs	1
Phases	1
Input voltage	85 – 264 VAC, 88 – 360 VDC
Input voltage (nominal)	115 VAC, 230 VAC, 88 – 360 VDC
Output voltage [VDC]	24
Output current [A]	5
Power [W]	120

Protection via a motor protection switch

NOTE

Adjust the response of the current-sensing tripping device to 6 A.

Protection via a motor protection switch is practical where multiple controllers are to be operated on a 24 V bus and the products are to be used in continuous operation, e.g., driving linear axes.

The following motor protection switch manufactured by SIEMENS is recommended:

Type	3RU2116-1Hxx overload protection relay 5.5–8.0 A motor protection switch
------	---

5.3 Connecting the ground cable (functional ground)

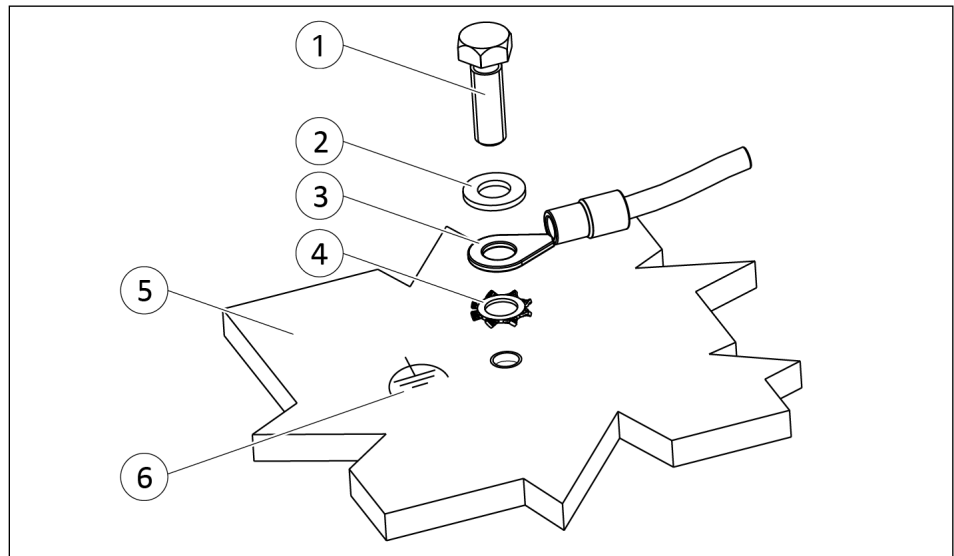

Ground connection

1	Screw *	4	Toothed lock washer
2	Washer	5	Product
3	Cable lug	6	Ground marking

*) M4x60; Tightening torque: 5 Nm



A ground connection with a sufficient cross-section must be established between the product and the machine on the customer's premises.

Mount the ground cable (functional ground) on the threaded hole marked with the ground marking.

NOTE

Only connect the ground cable (functional ground) at the location intended for this purpose.

Always mount the ground cable individually. A green-yellow wire strand color is not permitted.

Always use all components to fasten the ground cable (functional ground) and install them in this order: toothed lock washer, cable lug, washer and screw. See "Ground connection" diagram. Observe the tightening torque.

5.4 Air purge connection for dust-tight (SD) variant

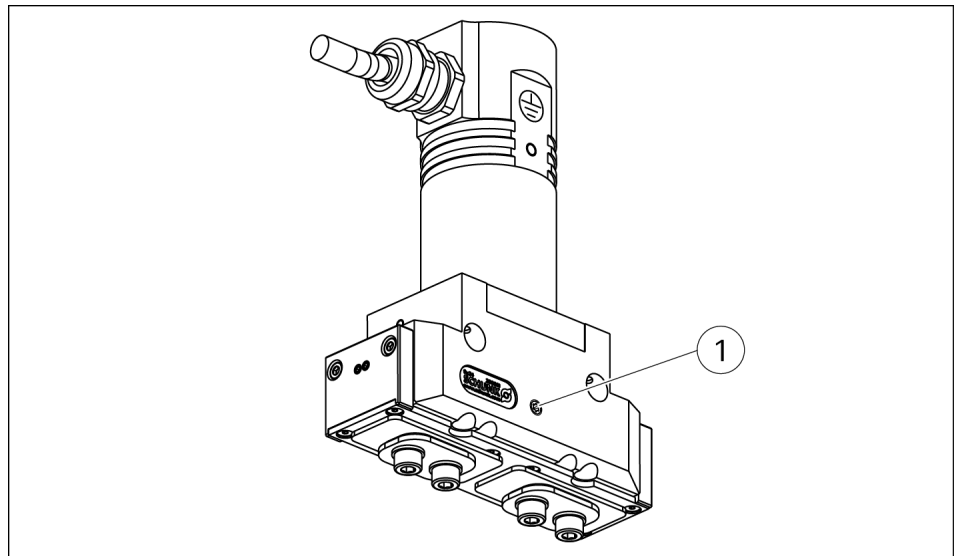

Item	Mounting	EGN		
		80	100	160
1	Thread in air purge connection	M4	M5	M5
	Maximum depth of engagement [mm] (from locating surface)		6	

CAUTION

Property damage due to incorrect assembly!

If the dust-tight (SD) variant is operated without air purge, neither the function nor permanent tightness can be guaranteed. This can result in damage to the product.

- Connect the air purge to the air purge connection prior to starting-up the product.

The air purge is connected to the air purge connection via a pneumatic line. The air purge pressure should be between 0.2 and 0.5 bar.

The air purge serves to compensate for changing volumes within the gripper during the gripping motion. This ensures that no vacuum is created in the interior of the gripper and therefore no dirt is drawn into the gripper.

6 Start-up and system integration via ECM controller

NOTE

See Assembly and Operating Manual "ECM Controller" for instructions on start-up and system integration of the product via the ECM controller.

7 Troubleshooting

7.1 Behavior in case of product malfunctions

7.1.1 Product does not move

Possible cause	Corrective action
Spindle defective.	Open the product cover (cable connection) and attempt to move it. If the shaft now rotates but the jaws do not move, then the spindle is damaged. The product can only be repaired at the factory! Send the product to SCHUNK with a repair order.
Motor connected incorrectly.	Check connections on the motor.

7.1.2 Gripping force gets weaker

Possible cause	Corrective action
dirt deposits	Clean and if necessary re-lubricate.

7.1.3 Product does not execute a complete stroke

Possible cause	Corrective action
Dirt deposits between basic jaws and guidance.	Clean and if necessary re-lubricate.

7.1.4 Product opens or closes jerkily

Possible cause	Corrective action
dirt deposits	Clean and if necessary re-lubricate.

7.1.5 Motor rotates but does not move gripper

Possible cause	Corrective action
Fingers are mechanically jammed.	Check demands on evenness. ▶ 5.2.1 [27] Check whether the adapter plate is stepped (only in the case of lateral attachment).

7.1.6 The module's motor is not turning

Possible cause	Corrective action
Defective motor cables.	Check winding resistances: Motor cables to each other: approx 2.2 Ω Resolver cables: red/white to yellow/white: 24 – 48 Ω yellow to blue: 56 – 68 Ω black to red: 56 – 68 Ω

7.2 Behavior in event of malfunctions on the ECM controller

Identified errors are shown as hexadecimal code on the seven-segment display of the controller.

Information about the error codes are included in the software manual, see the "Controller ECM" Assembly and Operating Manual.

8 Maintenance

8.1 Maintenance intervals

CAUTION

Material damage due to hardening lubricants!

Lubricants harden more quickly at temperatures above 60°C, leading to possible product damage.

- Reduce the lubricant intervals accordingly.

For extreme ambient and application conditions, shortened maintenance cycles can ensure the lifespan is maintained.

Interval [Mio. cycles] for EGN 50 – 125	Maintenance work
2	Check wearing parts for damage and check wear, change O-rings, ▶ 8.4 [□ 41].
2	Supply greasing areas via a lubrication nipple on the air purge connection, ▶ 8.2 [□ 40].

8.2 Grease/greasing areas

Lubricate the product at every maintenance interval so that every greasing area is optimally lubricated with grease.

SCHUNK recommends the lubricants listed.

Lubricant point	Lubricant
Seals and sealing surfaces	SCHUNK grease 1
Metallic sliding surfaces	SCHUNK grease 3

Details regarding SCHUNK lubricant designations are available at schunk.com/lubricants.

The product contains food-compliant lubricants as standard. Components such as rolling bearings, linear guides, or shock absorbers are not provided with food-compliant lubricants.

The requirements of standard EN 1672-2:2020 are not fully met.

NOTE

- Change contaminated food-compliant lubricant.
- Observe information in the safety data sheet from the lubricant manufacturer.

8.3 Maintaining gripper without disassembling

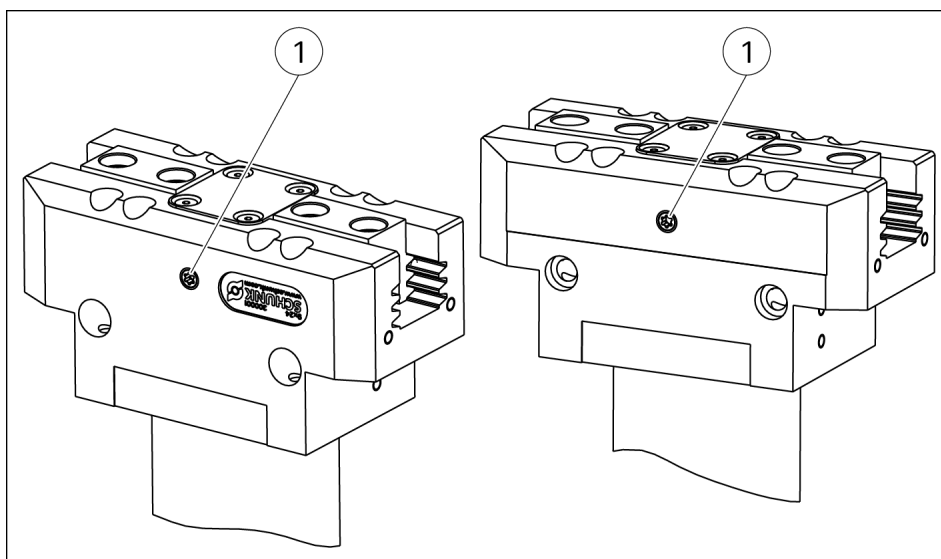

1. Remove set-screw on an air purge connection (1).
2. Screw in lubrication nipple.
3. Apply a layer of grease to metallic sliding surfaces of the gripper using the lubrication nipple, ► 8.2 [40].
 - ⇒ While lubricating, completely open and close the gripper alternately.
4. Unscrew the lubrication nipple.
5. Screw set-screw into the air purge connection (1).

8.4 Disassembly and assembling

This product must not be disassembled for maintenance.

CAUTION

Material damage due to improper disassembly!

Incorrect works can cause damage to the mechanics and internal electronics.

- Disassembly or opening of the product is not permitted.
- Only allow SCHUNK to repair the product.

8.5 Disassembling and assembling dust-proof variant

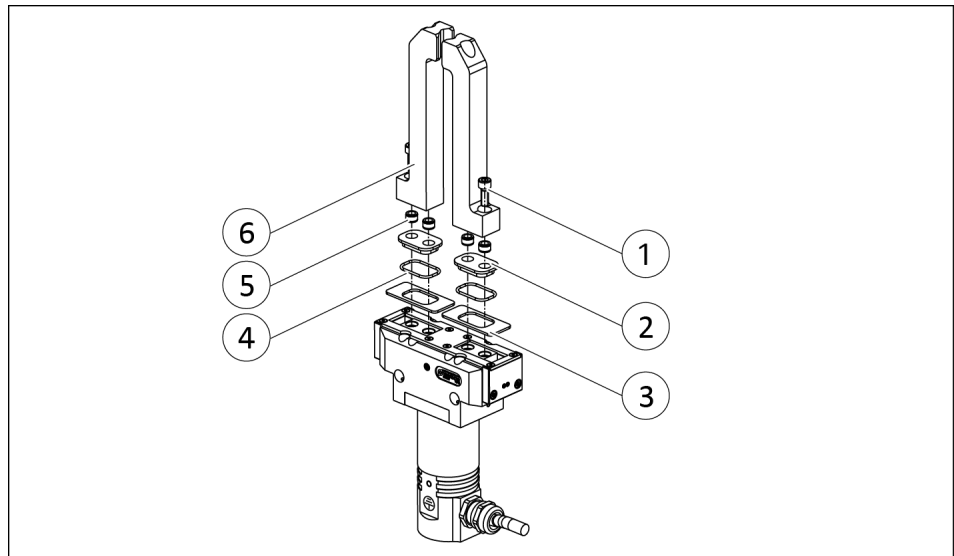

1. Unscrew screws (1) together with centering sleeves (5).
2. Remove intermediate jaw (2) with O-rings (4) and intermediate cover (3).
3. Lubricate sliding surfaces of the intermediate cover (3).
⇒ Apply a thin film of lubrication oil using a lint-free cloth.
4. Lubricate metallic sliding surfaces in the gripper via the lubrication nipple on the air purge connection, ▶ 8.3 [□ 41].
5. Replace intermediate cover (3) and apply the intermediate jaw (2) together with centering sleeves (5).
6. **IMPORTANT! Always use new O-rings (4) when installing the intermediate jaw (2).**
Measure the installation height of the O-ring (4) between the intermediate jaw (2) recess and intermediate cover (3). Select the appropriate O-ring from the "Size of the O-rings" table. O-rings are contained in the accessory pack or available from SCHUNK.
7. Remove the intermediate jaw (2) again and press the O-ring (4) onto the intermediate jaw (2).
8. Fasten intermediate jaw (2) together with gripper finger (6).
9. Carry out functional test of the gripper.

Sealing kit	ID no.	2 x O-ring [mm]	Installation dimension min. [mm]	Installation dimension max. [mm]
EGN 80-SD	1316610	∅ 22 x 1.5	0.95	1.35
		∅ 22 x 1.0	0.65	0.9

Sealing kit	ID no.	2 x O-ring [mm]	Installation dimension s min. [mm]	Installation dimension s max. [mm]
EGN 100-SD	1304644	∅ 25 x 1.5	0.95	1.35
		∅ 26 x 1.2	0.8	1.05
		∅ 25 x 1.0	0.65	0.9
EGN 160-SD	1304653	∅ 37.82 x 1.78	1.2	1.6
		∅ 37.10 x 1.6	1.05	1.4
		∅ 40 x 1.5	0.95	1.35

Tab.: Size of the O-rings

Testing the function of the gripper

1. Test function of the gripper with the "Motion Tool SCHUNK (MTS)" configuration and commissioning tool, see enclosed DVD.
 - ⇒ Carry out speed movement with parameters according to the following table.
 - ⇒ For installation and operation, see "Motion Tool SCHUNK (MTS)" software manual.
 - ⇒ The gripper must reach the end positions "opened" and "closed".
2. If the gripper does not reach the end positions, contact SCHUNK Service.

Gripper	End positions [mm]	Speed [mm/s]	Current [A]
EGN 80-SD	0 ... 16	2.0	1.2
EGN 100-SD	0 ... 20	2.0	1.3
EGN 160-SD	0 ... 32	2.0	1.8

Tab.: Test parameters

9 Translation of the original declaration of incorporation

in terms of the Directive 2006/42/EG, Annex II, Part 1 Section B.

Manufacturer/
Distributor SCHUNK SE & Co. KG
Spanntechnik | Greiftechnik | Automatisierungstechnik
Bahnhofstr. 106 – 134
D-74348 Lauffen/Neckar

We hereby declare that the partly completed machine described below

Product designation: 2-finger parallel gripper / EGN /electric
ID number 0306100 ... 0306106

meets the following basic occupational health and safety of the Machinery Directive 2006/42/EC:

No. 1.1.1, No. 1.1.2, No. 1.1.3, No. 1.1.5, No. 1.3.2, No. 1.5.1, No. 1.5.2; No. 1.5.4, No. 1.5.6, No. 1.5.8, No. 1.5.10, No. 1.5.11, No. 1.5.13

The partly completed machinery may not be put into operation until it has been confirmed that the machine into which the partly completed machinery is to be installed complies with the provisions of the Machinery Directive (2006/42/EC). The declaration shall be rendered invalid if modifications are made to the product.

Applied harmonized standards, especially:

EN ISO 12100:2010 Safety of machinery – General principles for design –
Risk assessment and risk reduction

The special technical documentation according to Annex VII, Part B, belonging to the partly completed machine, has been created.

Person authorized to compile the technical documentation:
Stefanie Walter, Address: see manufacturer's address

Signature: see original declaration

Lauffen/Neckar, November 2024

Dr.-Ing. Manuel Baumeister,
Head of Systems Engineering,
Technology & Innovation

11 Information on the RoHS Directive, REACH Regulation and Substances of Very High Concern (SVHC)

RoHS Directive

SCHUNK products are classified as "large-scale stationary installations" or as "large-scale stationary industrial tools" within the meaning of Directive 2011/65/EU and its extension 2015/863/EU "on the restriction of the use of certain hazardous substances in electrical and electronic equipment (RoHS)", or fulfill their intended function only as part of one. Therefore products from SCHUNK do not fall within the scope of the directive at this time.

REACH Regulation

Products from SCHUNK fully comply with the regulations of Regulation (EC) No. 1907/2006 "concerning the Registration, Evaluation, Authorization and Restriction of Chemicals (REACH)" and its amendment 2022/477. SCHUNK attaches great importance to completely avoiding chemicals of concern to humans and the environment wherever possible.

Only in rare exceptional cases do SCHUNK products contain SVHC substances on the candidate list with a mass content above 0.1%. In accordance with Article. 33 (1) of Regulation (EC) No. 1907/2006, SCHUNK complies with its duty to "communicate information on substances in articles" and lists the components concerned and the substances used in an overview that can be viewed at [schunk.com\SVHC](https://www.schunk.com/SVHC).

Signature: see original declaration

Lauffen/Neckar, November 2024

Dr.-Ing. Manuel Baumeister,
Head of Systems Engineering,
Technology & Innovation





SCHUNK SE & Co. KG
Spanntechnik | Greiftechnik | Automatisierungstechnik

Bahnhofstr. 106 - 134
D-74348 Lauffen/Neckar
Tel. +49-7133-103-0
info@de.schunk.com
schunk.com

Folgen Sie uns | *Follow us*



Wir drucken nachhaltig | *We print sustainable*