



Assembly and Operating Manual

WSG 50

Servo-electric 2-finger parallel gripper

Translation of the original manual

Hand in hand for tomorrow

Imprint

Copyright:

This manual is protected by copyright. The author is SCHUNK SE & Co. KG.
All rights reserved.

Technical changes:

We reserve the right to make alterations for the purpose of technical improvement.

Document number: 389474

Version: 07.00 | 29/05/2024 | en

Dear Customer,

Thank you for trusting our products and our family-owned company, the leading technology supplier of robots and production machines.

Our team is always available to answer any questions on this product and other solutions. Ask us questions and challenge us. We will find a solution!

Best regards,

Your SCHUNK team

Customer Management

Tel. +49-7133-103-2503

Fax +49-7133-103-2189

cmg@de.schunk.com



Please read the operating manual in full and keep it close to the product.

Table of Contents

1	General	6
1.1	About this manual	6
1.1.1	Presentation of Warning Labels	6
1.1.2	Applicable documents	6
1.2	Warranty	7
1.3	Scope of delivery	7
1.4	Accessories	7
2	Basic safety notes	8
2.1	Intended use	8
2.2	Not intended use	8
2.3	Constructional changes	8
2.4	Special standards	8
2.5	Spare parts	9
2.6	Gripper fingers	9
2.7	Environmental and operating conditions	9
2.8	Personnel qualification	9
2.9	Personal protective equipment	10
2.10	Notes on safe operation	11
2.11	Transport	11
2.12	Malfunctions	11
2.13	Disposal	12
2.14	Fundamental dangers	12
2.15	Notes on particular risks	13
3	Technical data	14
3.1	Outer dimensions	14
3.2	Nominal mechanical data	14
3.2.1	Permitted finger load	15
3.2.2	Gripping force	16
3.3	Nominal electrical data	19
3.4	Interfaces and connections	20
3.4.1	Assignments for the internal terminal strip	20
3.4.2	Connection of own lines	21
3.4.3	Termination resistors	22
3.4.4	Fuse	22
3.4.5	PROFIBUS	22
3.4.6	Power supply and RS 232 (serial interface)	23
3.4.7	Ethernet	24
3.4.8	Digital inputs/outputs	25

3.4.9	Base jaw with a sensor port	27
3.5	Name plate	29
4	Design and description	30
4.1	Design	30
4.2	Description	31
5	Assembly.....	32
5.1	Safety notes	32
5.2	Mechanical connection.....	32
5.3	Electrical connection.....	34
5.4	Installation of the fingers	36
6	Start-up	37
6.1	Initial commissioning.....	37
6.2	Changing the IP address and using DHCP	40
7	Operation.....	41
7.1	Operating software	41
7.2	Memory card	41
7.3	The boot process	42
7.4	Display of operating state	43
7.5	Status word and gripper state	44
7.5.1	Status word	44
7.5.2	Gripper state	45
7.6	Homing the product	47
7.7	Gripping, detecting parts to be gripped and monitoring the gripping	48
7.8	Software limit switch	50
7.9	Fast stops requiring acknowledgment.....	51
7.10	Log memory	52
7.11	Thermal monitoring.....	52
7.12	Monitoring the motor current	53
7.13	Monitoring the supply voltage	54
7.14	Overdrive mode	55
7.15	Configuration and diagnosis via the web interface	55
7.15.1	Access restrictions for the web user interface.....	57
7.16	Command interface	58
7.17	Scripting	58
7.18	Resetting the configuration	58
7.19	Implementing the gripping process.....	59
8	Maintenance and cleaning	61

9 Troubleshooting	62
9.1 The gripper jaws don't move	62
9.2 Gripper stops abruptly.....	62
9.3 No connection to the web interface	62
10 Translation of the original declaration of incorporation	63
11 Information on the RoHS Directive, REACH Regulation and Substances of Very High Concern (SVHC)	64

1 General

1.1 About this manual

This manual contains important information for a safe and appropriate use of the product.

This manual is an integral part of the product and must be kept accessible for the personnel at all times.

Before starting work, the personnel must have read and understood this operating manual. Prerequisite for safe working is the observance of all safety instructions in this manual.

In addition to these instructions, the documents listed under ▶ 1.1.2 [📄 6] are applicable.

NOTE: The illustrations in this manual are intended to provide a basic understanding and may deviate from the actual version.

1.1.1 Presentation of Warning Labels

To make risks clear, the following signal words and symbols are used for safety notes.



⚠ DANGER

Dangers for persons!

Non-observance will inevitably cause irreversible injury or death.



⚠ WARNING

Dangers for persons!

Non-observance can lead to irreversible injury and even death.



⚠ CAUTION

Dangers for persons!

Non-observance can cause minor injuries.

CAUTION

Material damage!

Information about avoiding material damage.

1.1.2 Applicable documents

- General terms of business *
- Catalog data sheet of the purchased product *
- Assembly and operating manuals of the accessories *

- WSG Command Set Reference – Description of the binary command protocol (RS-232, TCP/IP) *
- WSG GCL Reference Manual – Description of the text-based command protocol (TCP/IP) *
- WSG Documentation for the fieldbus interface – Description of the fieldbus interface (PROFIBUS, PROFINET, Modbus/TCP) *
- WSG Scripting Reference Manual – Description of the script interpreter for the gripper control system *

The documents labeled with an asterisk (*) can be downloaded from [schunk.com/downloads](https://www.schunk.com/downloads).

1.2 Warranty

If the product is used as intended, the warranty is valid for 24 months from the ex-works delivery date under the following conditions:

- Observe the specified maintenance and lubrication intervals
- Observe the ambient conditions and operating conditions

Parts touching the workpiece and wear parts are not included in the warranty.

The product is considered defective if its basic function "gripping" is no longer given.

1.3 Scope of delivery

The scope of delivery includes

- Servo-electric 2-finger parallel gripper WSG 50 in the version ordered
- 3 m network cable 4-pole M8 to RJ-45
- EMC screw connection M12x1,5

1.4 Accessories

The following accessories, which must be ordered separately, are required for the product:

- Ethernet-Kabel 5 m, 4-pole M8-plug straight, angular to RJ-45, for WSG gripper
- Power supply cable 5 m, 4-pole M8-socket straight, angular to free wire ends
- Centering sleeves, $\varnothing 6.0 \times 5.35$, outer diameter 6h6
- Technology package PROFINET TR (software license)
- Universal finger ABF WSG32/50-GV
- Force measurement finger ABF WSG32/50-DV

2 Basic safety notes

2.1 Intended use

The product is designed exclusively for gripping and temporarily holding workpieces or objects.

- The product may only be used within the scope of its technical data, ▶ 3 [14].
- The product is intended for installation in a machine/ automated system. The applicable guidelines for the machine/ automated system must be observed and complied with.
- The product is intended for industrial and industry-oriented use. Its use outside enclosed spaces is only permitted if suitable protective measures are taken against outdoor exposure. The product is not suitable for use in salty air.
- The product can be used within the permissible load limits and technical data for holding workpieces during simple machining operations, but is not a clamping device according to EN 1550:1997+A1:2008.
- Appropriate use of the product includes compliance with all instructions in this manual.
- Any utilization that exceeds or differs from the appropriate use is regarded as misuse.

2.2 Not intended use

It is not intended use if the product is used, for example, as a pressing tool, stamping tool, lifting gear, guide for tools, cutting tool, clamping device or a drilling tool.

- Any utilization that exceeds or differs from the appropriate use is regarded as misuse.

2.3 Constructional changes

Implementation of structural changes

Modifications, changes or reworking, e.g. additional threads, holes, or safety devices, can damage the product or impair its functionality or safety.

- Structural changes should only be made with the written approval of SCHUNK.

2.4 Special standards

The following standards are met:

- Fast transients on supply and I/O lines (burst) to IEC / EN 61000-4-4
- HF power supply to IEC/EN 61000-4-6

- HF radiation according to IEC/EN 61000-4-3
- Emissions according to EN 55011:2009 Class A (corresponds to EN 61000-6-4:2007)
- Magnetic field with energy technical frequency according to EN 61000-4-8

2.5 Spare parts

Use of unauthorized spare parts

Using unauthorized spare parts can endanger personnel and damage the product or cause it to malfunction.

- Use only original spare parts or spares authorized by SCHUNK.

2.6 Gripper fingers

Requirements of gripper fingers

Accumulated energy can make the product unsafe and risk the danger of serious injuries and considerable material damage.

- Execute the gripper fingers in such a way that the product reaches either the "open" or "closed" position in a de-energized state.
- Only change gripper fingers if no residual energy can be released.
- Make sure that the product and the top jaws are a sufficient size for the application.

2.7 Environmental and operating conditions

Required ambient conditions and operating conditions

Incorrect ambient and operating conditions can make the product unsafe, leading to the risk of serious injuries, considerable material damage and/or a significant reduction to the product's life span.

- Make sure that the product is used only in the context of its defined application parameters, ▶ 3 [14].
- Observe Maintenance intervals, ▶ 8 [61].
- Make sure that the environment is clean and the ambient temperature corresponds to the specifications per the catalog.

2.8 Personnel qualification

Inadequate qualifications of the personnel

If the personnel working with the product is not sufficiently qualified, the result may be serious injuries and significant property damage.

- All work may only be performed by qualified personnel.

- Before working with the product, the personnel must have read and understood the complete assembly and operating manual.
- Observe the national safety regulations and rules and general safety instructions.

The following personal qualifications are necessary for the various activities related to the product:

Trained electrician

Due to their technical training, knowledge and experience, trained electricians are able to work on electrical systems, recognize and avoid possible dangers and know the relevant standards and regulations.

Qualified personnel

Due to its technical training, knowledge and experience, qualified personnel is able to perform the delegated tasks, recognize and avoid possible dangers and knows the relevant standards and regulations.

Instructed person

Instructed persons were instructed by the operator about the delegated tasks and possible dangers due to improper behaviour.

Service personnel of the manufacturer

Due to its technical training, knowledge and experience, service personnel of the manufacturer is able to perform the delegated tasks and to recognize and avoid possible dangers.

2.9 Personal protective equipment

Use of personal protective equipment

Personal protective equipment serves to protect staff against danger which may interfere with their health or safety at work.

- When working on and with the product, observe the occupational health and safety regulations and wear the required personal protective equipment.
- Observe the valid safety and accident prevention regulations.
- Wear protective gloves to guard against sharp edges and corners or rough surfaces.
- Wear heat-resistant protective gloves when handling hot surfaces.
- Wear protective gloves and safety goggles when handling hazardous substances.
- Wear close-fitting protective clothing and also wear long hair in a hairnet when dealing with moving components.

2.10 Notes on safe operation

Incorrect handling of the personnel

Incorrect handling and assembly may impair the product's safety and cause serious injuries and considerable material damage.

- Avoid any manner of working that may interfere with the function and operational safety of the product.
- Use the product as intended.
- Observe the safety notes and assembly instructions.
- Do not expose the product to any corrosive media. This does not apply to products that are designed for special environments.
- Eliminate any malfunction immediately.
- Observe the care and maintenance instructions.
- Observe the current safety, accident prevention and environmental protection regulations regarding the product's application field.

2.11 Transport

Handling during transport

Incorrect handling during transport may impair the product's safety and cause serious injuries and considerable material damage.

- When handling heavy weights, use lifting equipment to lift the product and transport it by appropriate means.
- Secure the product against falling during transportation and handling.
- Stand clear of suspended loads.

2.12 Malfunctions

Behavior in case of malfunctions

- Immediately remove the product from operation and report the malfunction to the responsible departments/persons.
- Order appropriately trained personnel to rectify the malfunction.
- Do not recommission the product until the malfunction has been rectified.
- Test the product after a malfunction to establish whether it still functions properly and no increased risks have arisen.

2.13 Disposal

Handling of disposal

The incorrect handling of disposal may impair the product's safety and cause serious injuries as well as considerable material and environmental harm.

- Follow local regulations on dispatching product components for recycling or proper disposal.

2.14 Fundamental dangers

General

- Observe safety distances.
- Never deactivate safety devices.
- Before commissioning the product, take appropriate protective measures to secure the danger zone.
- Disconnect power sources before installation, modification, maintenance, or calibration. Ensure that no residual energy remains in the system.
- If the energy supply is connected, do not move any parts by hand.
- Do not reach into the open mechanism or movement area of the product during operation.

2.15 Notes on particular risks



⚠ WARNING

Risk of injury from objects falling and being ejected!

Falling and ejected objects during operation can lead to serious injury or death.

- Take appropriate protective measures to secure the danger zone.



⚠ WARNING

Risk of injury from crushing and impacts!

Serious injury could occur during movement of the base jaw, due to breakage or loosening of the gripper fingers or if the workpiece is lost.

- Wear suitable protective equipment.
- Do not reach into the open mechanism or the movement area of the product.



⚠ WARNING

Risk of injury due to unexpected movements!

If the power supply is switched on or residual energy remains in the system, components can move unexpectedly and cause serious injuries.

- Before starting any work on the product: Switch off the power supply and secure against restarting.
- Make sure, that no residual energy remains in the system.

3 Technical data

3.1 Outer dimensions

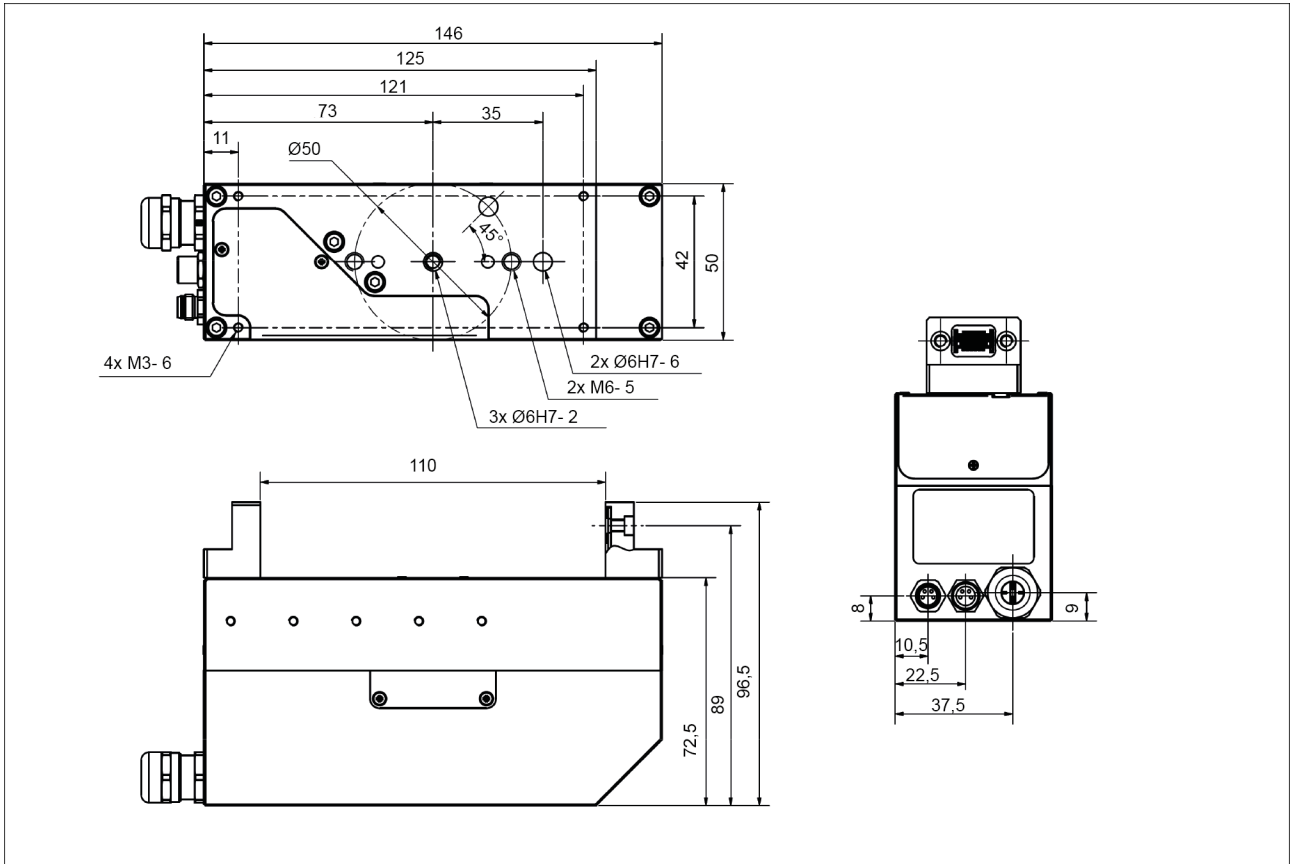

Outer dimensions

3.2 Nominal mechanical data

CAUTION

Exceeding the specified nominal data can damage the product.

- If in doubt, please discuss your application with SCHUNK.

Mechanical operating data	Value	Note
Stroke per finger [mm]	55	
Nominal gripping force [N]	80	
Min. Gripping force [N]	5	gripping speed 5 mm/s, finger length 170 mm, steel on steel
Max. Gripping force [N]	80	gripping speed 50 mm/s, finger length 170 mm, steel on steel
Max. Gripping force [N] (overdrive mode)	120	Overdrive mode activated, gripping speed 50 mm/s, finger length 80 mm, steel on steel
Weight [kg]	1.15	
Recommended workpiece weight [kg]	0.8	

Mechanical operating data	Value	Note
Max. permissible finger length [mm]	170	At nominal force, definition finger length see following figure "Determining the clamping height"
Max. permitted weight per finger [kg]	0.3	
IP rating	20	DIN EN 60529
Ambient temperature [°C]		
Min.	5	
Max.	50	
Air humidity [%]		Non condensing
Min.	0	
Max.	90	
Repeatability [mm]	±0.03	3σ-deviation
Gripping speed [mm/s]		Finger to finger
Min.	5	
Max.	420	
Finger acceleration [mm/s ²]		Finger to finger
Min.	100	
Max.	5000	

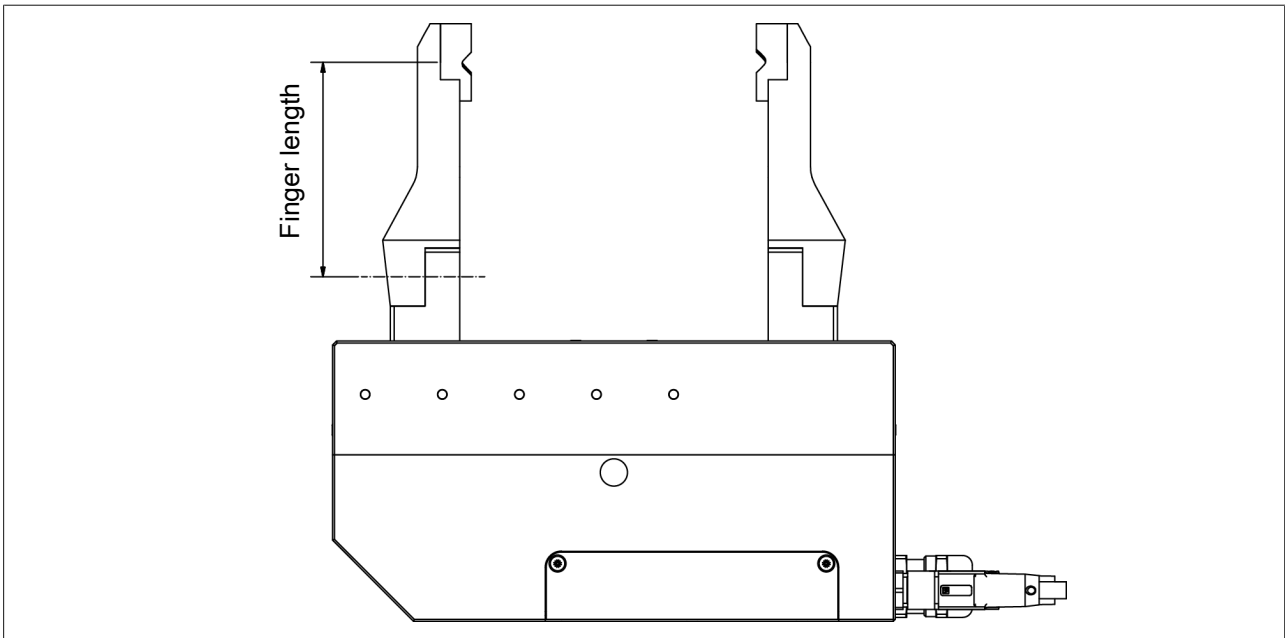

Determining the clamping height

3.2.1 Permitted finger load

The following table shows the permitted load of the finger. The specified load may be applied simultaneously and in addition to the gripping force.

Mechanical Load	Value
Fz [N], max.	80
Mx [Nm], max.	3
My [N], max.	3
Mz [N], max.	2

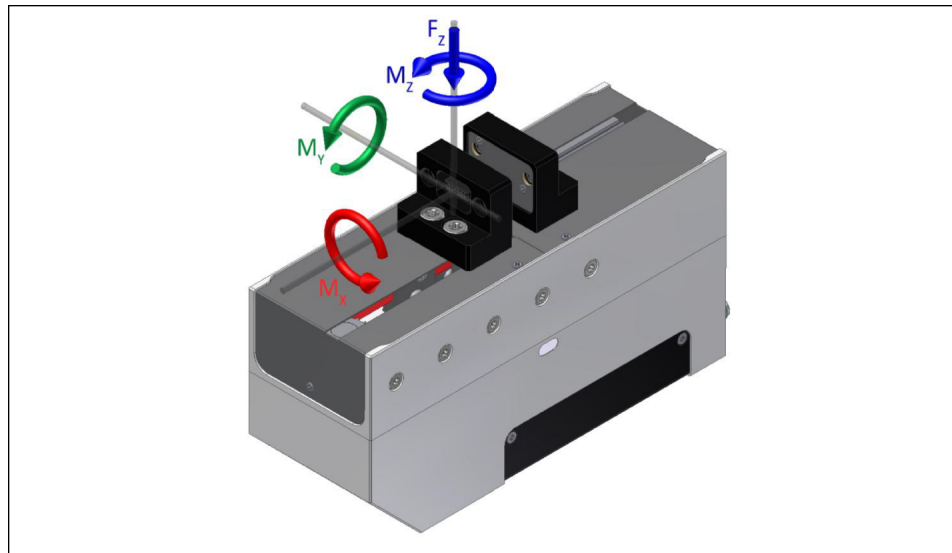

Finger load

3.2.2 Gripping force

The maximum permissible gripping force depends upon the selected clamping height. The clamping height is the clearance between the finger fixing screws and the force point, as shown in the figure above "Determining the clamping height".

NOTE

The actual gripping force is influenced by external factors like clamping height, motor temperature or gripping speed. To make sure the gripping force does not exceed a given force limit, please measure the actual gripping force when setting up the product or use the force measurement finger.

To operate the product without a force measurement finger, the force is factory calibrated. The gripping force depends on the speed and this is shown in following figure for various force values against speed, as an example.

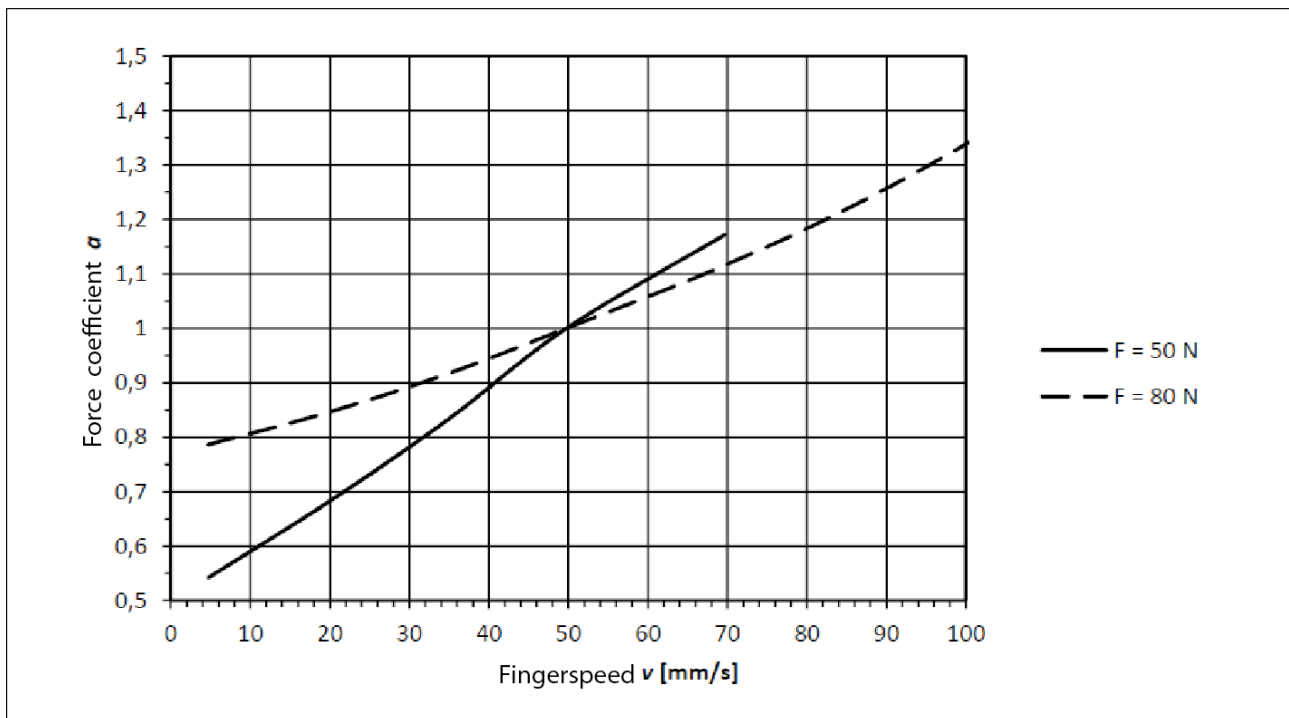

Influence of the gripping speed to the set of gripping force

The clamping height has also influence on the actual gripping force.

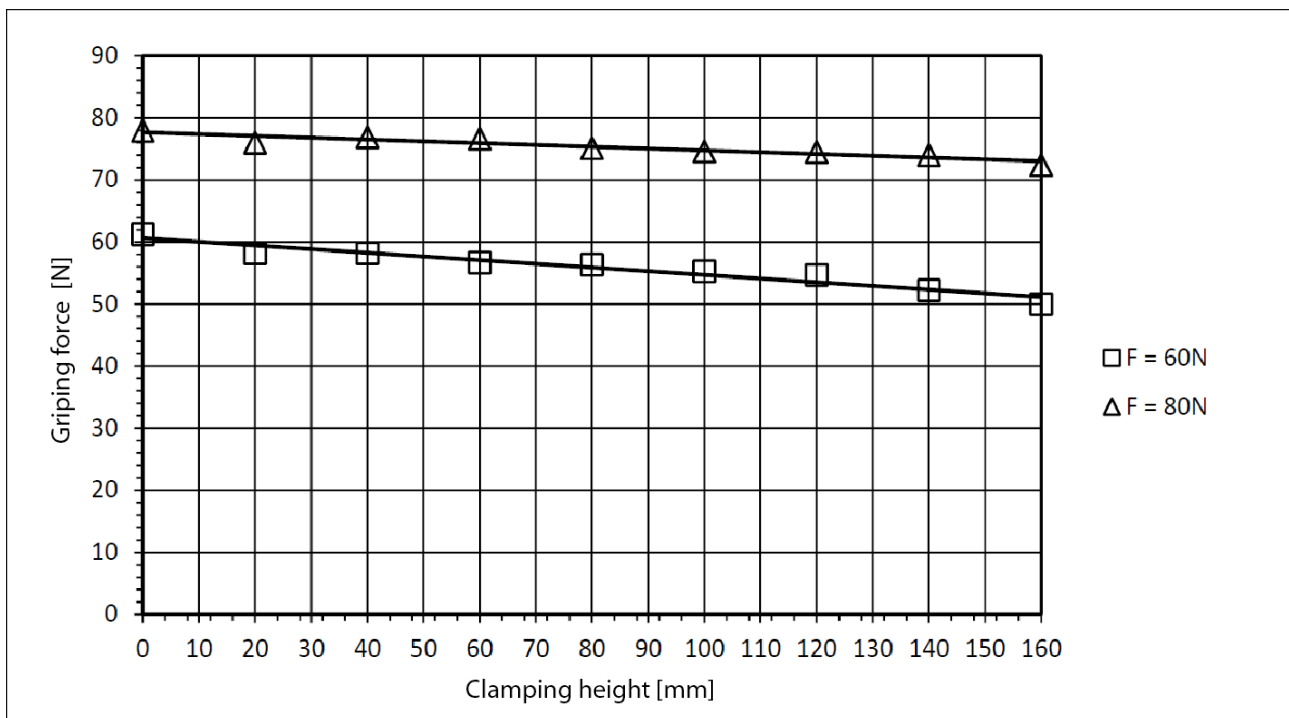

Gripping force in dependence of the clamp height

Definition of the nominal gripping force

To determine the nominal gripping force, the product is non-positively mounted to an aluminum plate, see following figure. The plate itself is thermally insulated from the underlying surface. With an ambient temperature of 22° C the product can hold with the nominal gripping force for at least 5 hours.

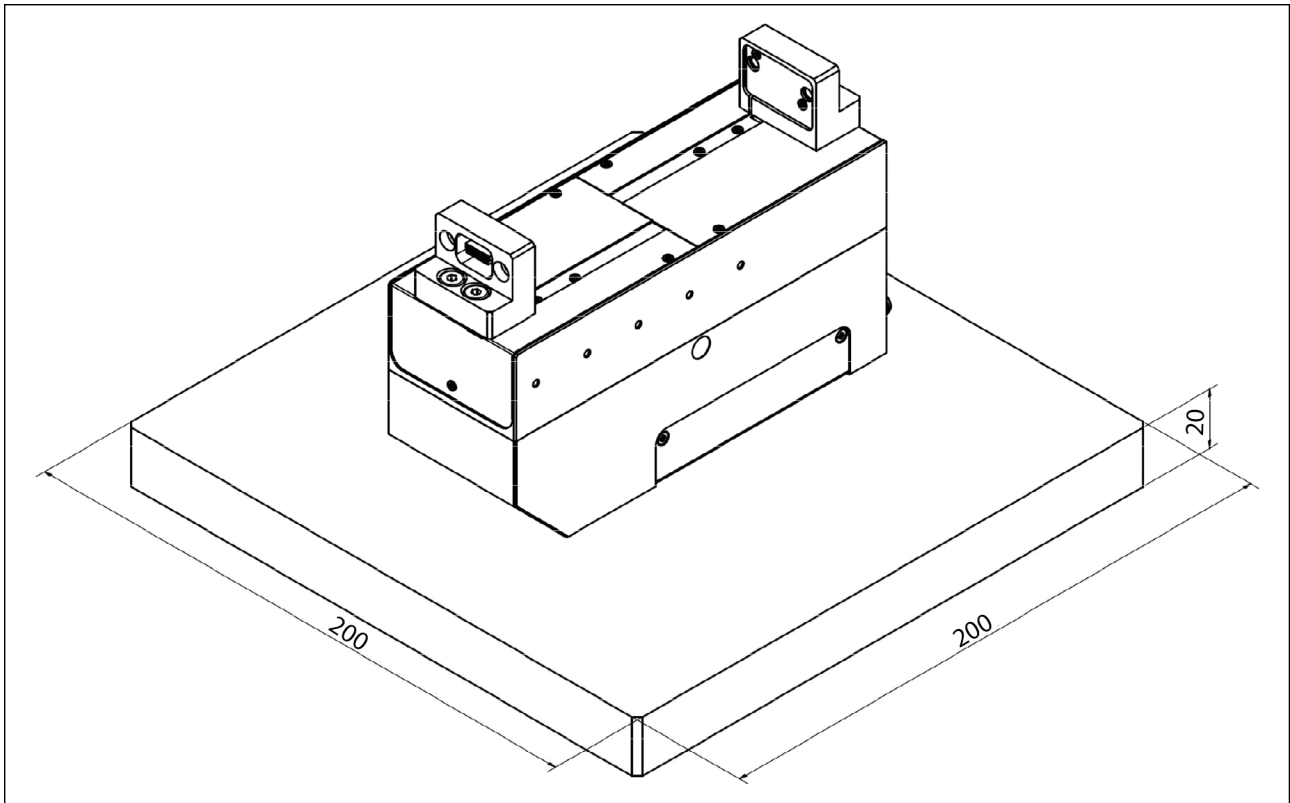

Arrangement for ascertaining the nominal gripping force

CAUTION

For high gripping forces or long holding cycles, make sure that heat is well dissipated via the screw contact surface. Damage to the product is possible!

3.3 Nominal electrical data

CAUTION

Exceeding the specified nominal data can damage the product.

- If in doubt, please discuss your application with SCHUNK.

Electrical operating data	Value	Note
Terminal voltage [V DC]		
Min.	22	
Typical	24	
Max.	28	
Current input in idle state [A]	0.1	
Current input during clamping [A]	0.85	Gripping force=80 N
Position resolution [μm]	1.09	
Controller	integrated	
Fieldbus interface	Ethernet PROFIBUS DPv0 PROFINET RT (optional) RS-232 IO	
Parametrized interface	web-based	

3.4 Interfaces and connections

The product has various interfaces for control. The communications interface is selected and configured via the web-based user interface, ▶ 7.15 [📄 55].

3.4.1 Assignments for the internal terminal strip

All interfaces are accessible via the product's integrated terminal strip, which is located underneath the connector cover.

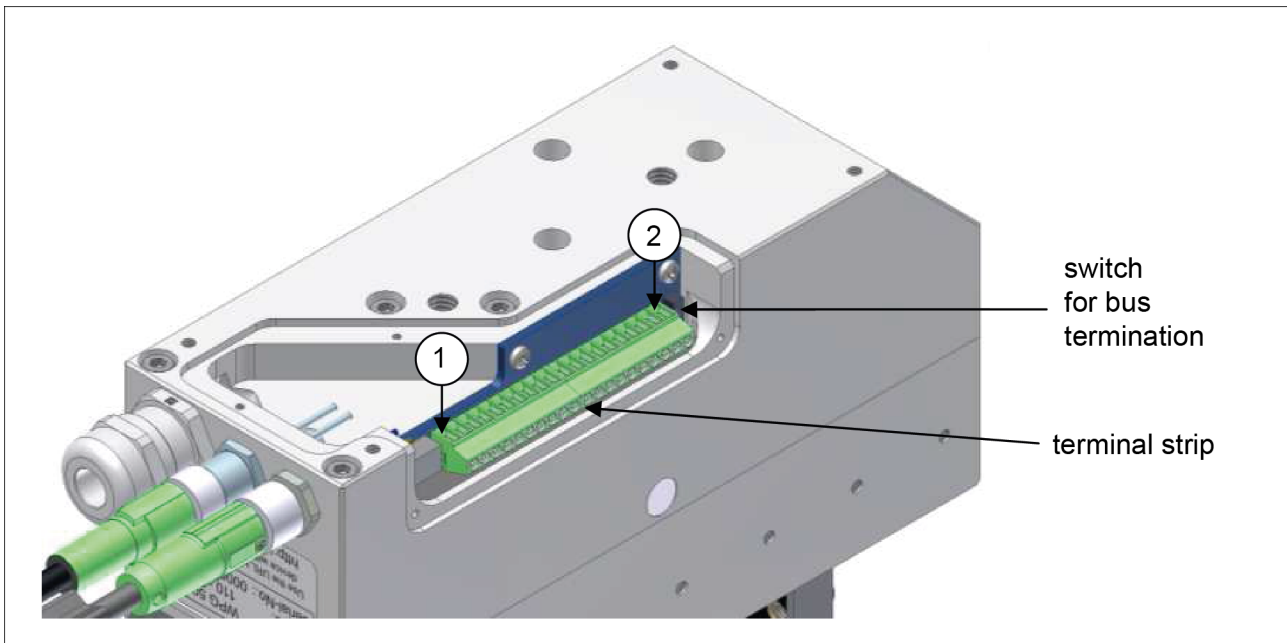

Integrated terminal strip and termination resistors

Terminal	Designation	Function
1	CASE	Housing (protective conductor)
2	+24V LOGIC	Supply voltage for the logic parts: +24V DC optional, connection options, ▶ 5.3 [📄 34]
3	+24V POWER	Supply voltage for the logic parts: +24V DC or common supply connection for power and logic
4	GND	Supply voltage: ground
5	ENTD+	Ethernet: Transmission line +
6	ENTD-	Ethernet: Transmission line -
7	ENRD+	Ethernet: Receiving line +
8	ENRD-	Ethernet: Receiving line -
9	TXD	RS-232: Data output

Terminal	Designation	Function
10	RXD	RS-232: Data input
11	GND	Ground, reference voltage for RS-232
12	GND ₁₀	Ground, reference voltage for Profibus and digital I/O
13	-	not assigned
14	-	not assigned
15	PROFI-A	Profibus: A line, RxD/TxD-N (pin 8 of the 9-way SUB-D connector)
16	PROFI-B	Profibus: B line, RxD/TxD-P (pin 3 of the 9-way SUB-D connector)
17	OUT0	digital output
18	OUT1	digital output
19	IN0	digital input
20	IN1	digital input

With the exception of the RS-232 interface, the interfaces are electrically isolated from the control system. The interfaces use the same reference voltage GND₁₀, which is accessible via the integrated terminal strip. Should isolating the interface lines not be desired, then the GND and GND₁₀ pins can be bridged.

3.4.2 Connection of own lines

A separate line can be connected to facilitate use of the integrated interface for Profibus as well as for the I/O pins. Please note that only shielded cables can be used, and the supplied threaded EMC cable gland is used to feed the cable through the intended hole in the housing. This is the only way to ensure that the module still conforms to the EMC standards and meets the given interface specifications, even after you have connected your own cables. When screwing in the EMC cable gland, ensure that the metal springs in the cable gland are in clean contact with the cable's braided shield as shown in the following illustration.

EMC cable gland:

Manufacturer: U.I. Lapp GmbH, Stuttgart, Type: SKINTOP MS-SC-M, Item number: 53112610.

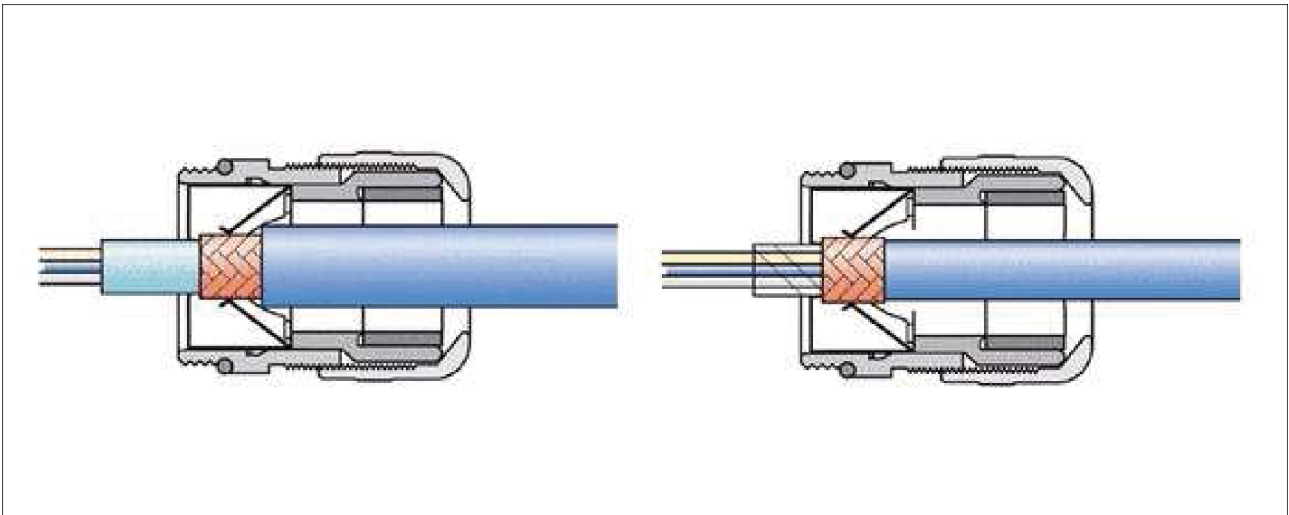

Installation of the EMC cable gland

NOTE

SCHUNK recommends only using shielded cables and EMC cable glands.

3.4.3 Termination resistors

The product has a switchable terminating resistor. The terminating resistor must be set for the first and last device on the bus. For termination, the two switches (3) and (4) must be switched on.

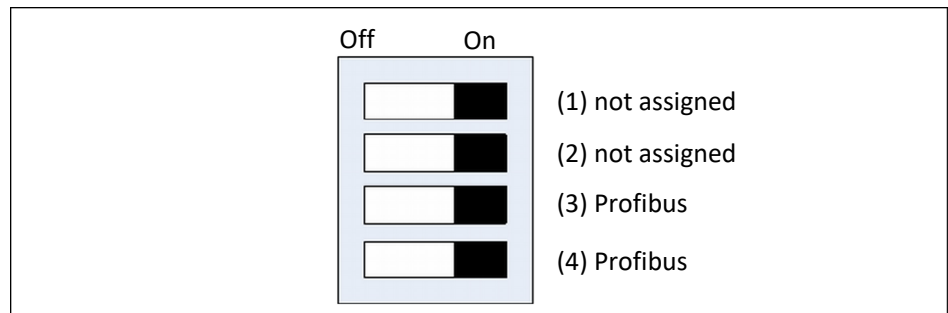

Settings of the switches to terminate the bus

3.4.4 Fuse

The product has an integrated fuse to protect against short circuits and incorrect polarity.

To have the fuse changed, please contact SCHUNK (Tel. +49 7133-103-2333).

3.4.5 PROFIBUS

The electrically isolated PROFIBUS interface is accessible via the integrated terminal strip. It has a switchable termination conforming to EIA RS485. Bus activity is shown via a separate light emitting diode in the memory card slot.

Parameter	Unit	Min.	Typical	Max.	Remark
Bus standard		PROFIBUS DP-V0			EN 50170
Supported bit rates	kBit/s	9.6; 19.2; 45.45; 93.75; 187.5; 500; 3000; 6000; 12000			
Insulation voltage	V_{peak}		560		VDE 0884, rev. 2
Voltage on A/B cable	V_{peak}	-7		12	relative to GND_{10}

3.4.6 Power supply and RS 232 (serial interface)

Power is supplied via a 4-way M8 plug connector on the product's housing, which also carries the RS 232 serial interface. This can be used to give commands to the product. The serial interface is not electrically isolated and uses the product's GND connection as its reference voltage. The connection assignments are shown in the following illustration.

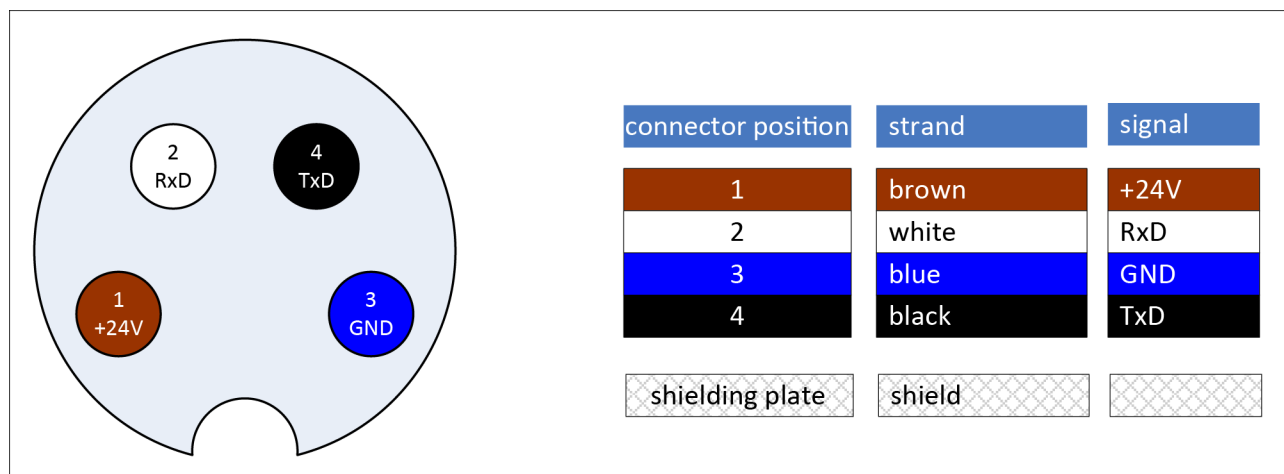

Connection assignments for the connector carrying the power supply and RS 232 signal (view of connection plug)

Requirement for the power supply

- Voltage supply: 24 V DC $\pm 10\%$
- Ripple $< 150 \text{ mV}_{SS}$
- Available output current: at least 3 A

The following cables from SCHUNK are suitable for connecting the voltage supply:

- Type: KA GLN0804-LK-00500-A power cable 5 m, 4 pole. M8 connector straight on open wire strands, ID. no. 0307767

- Type: KA WLN0804-LK-00500-A power cable 5 m, 4 pole. M8 connector at an angle on open wire strands, ID. no. 0307765

CAUTION

Please note that the maximum cable length of 15 m for communication via RS 232 must not be exceeded. In an environment with severe electromagnetic disturbances, e.g. areas near large electric drives, this length must be further reduced in some circumstances. If in doubt, perform some tests.

Interface specification RS 232:

Parameter	Unit	Min.	Type	Max.	Remark
Output level (TxD)	V	±5.0	±5.7		Load resistance = 3 kΩ
Input voltage range (RxD)	V	-30		30	relative to GND
High input level	V	-30		1.3	relative to GND
Low input level	V	2.4		30	relative to GND
Supported bit rates	kBit/s	1.2; 2.4; 4.8; 9.6; 19.2; 38.4; 57.6; 115.2; 230.4; 460.8			
Data format		8 data bits, no parity, 1 stop bit (8n1)			
Flow control		none			

3.4.7 Ethernet

The Ethernet interface can be used both for commands as well as for configuration via the integrated web server. It is presented via a 4-way M8 connector (socket).

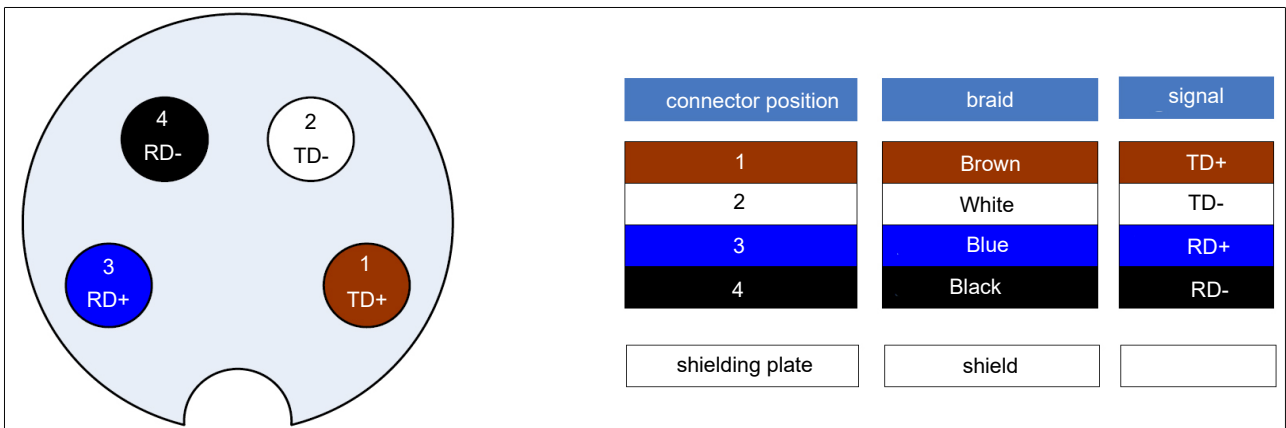

Pin assignment of the Ethernet connector (view on the socket).

The following cables are suitable to connect the Ethernet interface:

- Type: KA GGN0804-PG-00500-R Ethernet cable, length 5m, 4 pole M8 connector straight to RJ-45, Ident-No. 0349621
- Type: KA GGN0804-PG-00500-R Ethernet cable, length 5m, 4 pole M8 connector at an angle to RJ-45, Ident-No. 0349623

Commands are sent to the product via TCP/IP connections, using the TCP or UDP protocol. For further information, please see the "WSG Command Set Reference Manual" (can be called up via the web interface).

The product currently also supports the following network services:

- DHCP (dynamic IP addresses)
- SNTP (network time)
- HTTP (web user interface)
- Multicast DNS (decentralized resolution of host names)

Interface specification:

Parameter	Value	Note
Transmission standard	IEEE 802.3	
Communication standard	TCP/IP (IPv4)	
Transmission speed [MBit/s]	10; 100	Auto-Negotiated
Transmission type	Half duplex	
Auto-MDIX	yes	

3.4.8 Digital inputs/outputs

The product has two electrically isolated inputs and two outputs on the integrated terminal strip. The equivalent circuits for the input and output stages are shown in the following figures.

Interface specification:

Parameter	Unit	Min.	Typ.	Max.	Remark
Insulation voltage	V_{peak}		560		VDE 0884, Rev. 2
High input voltage	V	3.4	24	28	relative to GND_{10}
Low input voltage	V	-0.5	0	1.1	relative to GND_{10}
Output type		Open drain			
External voltage on the output	V			30	relative to GND_{10}
Increase in voltage on the output	V	0.032	0.1	0.3	Output current = 20mA
Increase in voltage on the output	V	0.16	0.5	1.5	Output current = 100mA

Parameter	Unit	Min.	Typ.	Max.	Remark
permissible output current	mA		100		

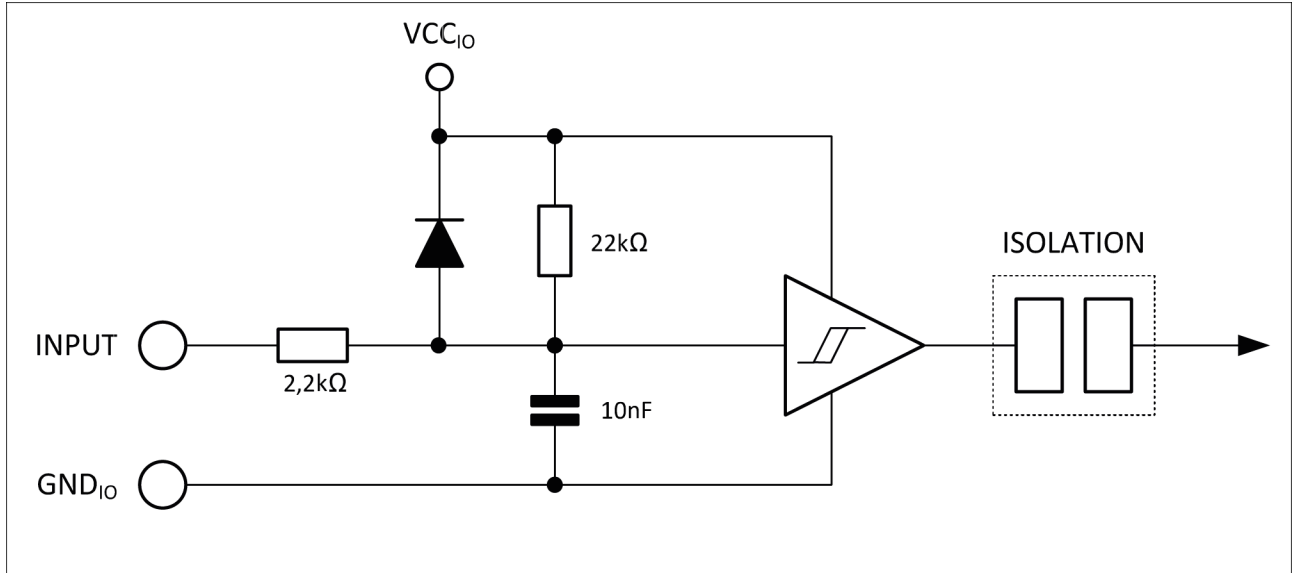

Equivalent circuit of the input stage

NOTE

$VCC_{10}(5V)$ is a intern generated, isolated supply voltage.

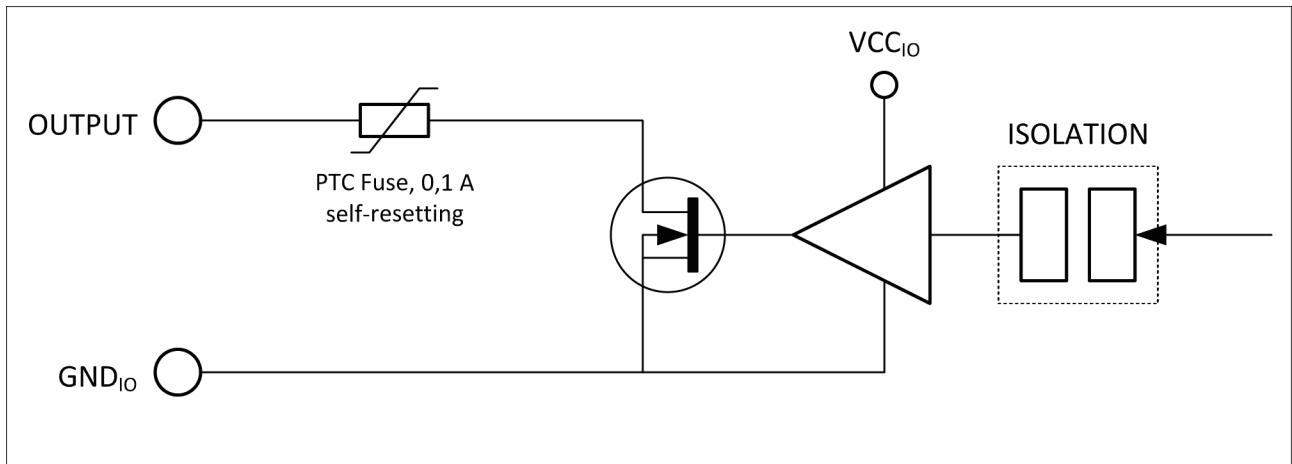

Equivalent circuit of the output stage

NOTE

$VCC_{10}(5V)$ is a intern generated, isolated supply voltage.

CAUTION

Inductive loads can damage the output stages.

- Wire a protective diode antiparallel to the output.

3.4.9 Base jaw with a sensor port

The product has an integrated sensor port in each of the base jaws which makes it easy to connect intelligent gripper fingers. The sensor port makes the following interfaces available:

- UART (LVTTTL levels)
- SPI (LVTTTL levels)
- Analog input (0 to 2.5 V)

The sensor port supports the automatic configuration of the connected fingers. To use this function, a configuration memory must be integrated into the fingers. All of the intelligent fingers offered by SCHUNK for this gripper (e.g. force measurement finger) already have this memory integrated and are completely configured, so that you just have to fit this finger to the product. The fingers will then be automatically detected the next time the system starts.

The sensor port supplies an operating voltage of 5 V \pm 10% at max. 200 mA. The supply voltage is protected against short circuits and can be switched on and off from the gripper control system. A short circuit in the supply voltage will trigger an error state which must be acknowledged.

NOTE

The power supply from the sensor port is not suitable to supply actuators.

CAUTION

The gripper control system may be destroyed by excess voltage on the sensor port pins!

The digital pins on the sensor port are protected against electrostatic discharge. However, SCHUNK still recommends that you should not directly touch the pins on the connector with fingers, to avoid damage from electrostatic discharge. The SPI and UART digital interfaces share transmit and receive pins. The configuration memory determines which function is active.

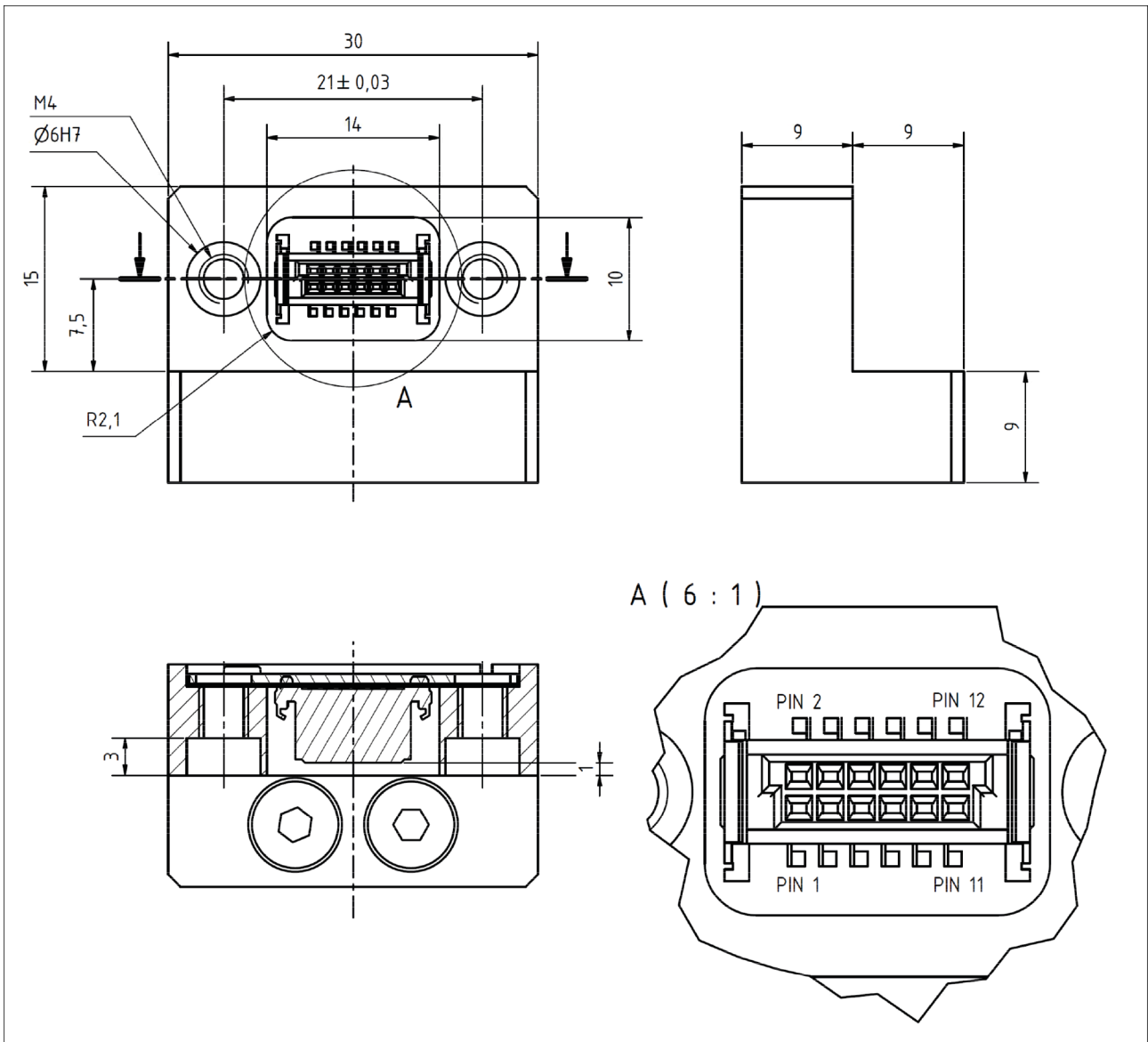

Sensor port

Should you require detailed specifications of the sensor port to implement your own fingers, please contact SCHUNK.

Matching centering sleeves

Matching centering sleeves are supplied with the fingers. For your own designs or as a spare part, please use the centering sleeves which are available as accessories, described as: centering sleeve $\varnothing 6.0 \times 5.35$ (outer diameter: 6h6).

Sensorport connector type

Manufacturer: ERNI, type: SMC-B-12 (terminal strip), part number: 154805

Counterpiece: SMC-Q-12 (male, low-profile connector), part number: 154818

Sensor port connector pin assignments

Pin number	Name	Direction	Function
1	MOSI/TXD	OUT	SPI/UART: Transmit data from the manual controller
2	nSSEL	OUT	Only SPI: A low signal selects the slave
3	AN	IN	Analog input. Voltage range: 0 to 2.5 V
4	SCLK	OUT	Only SPI: Clock for transmit and receive data
5	CFG-SDA	I/O	Configuration bus – data line
6	MISO/RXD	IN	SPI/UART: Received data
7	CFG-SCL	OUT	Configuration bus – clock line
8	NC	-	not connected
9	+5V	OUT	Operating voltage output 5V/200mA max.
10	+5V		
11	GND	OUT	Mass
12	GND		

3.5 Name plate

The name plate is on the narrow side of the product above the connector. It shows the type and the serial number of the product.

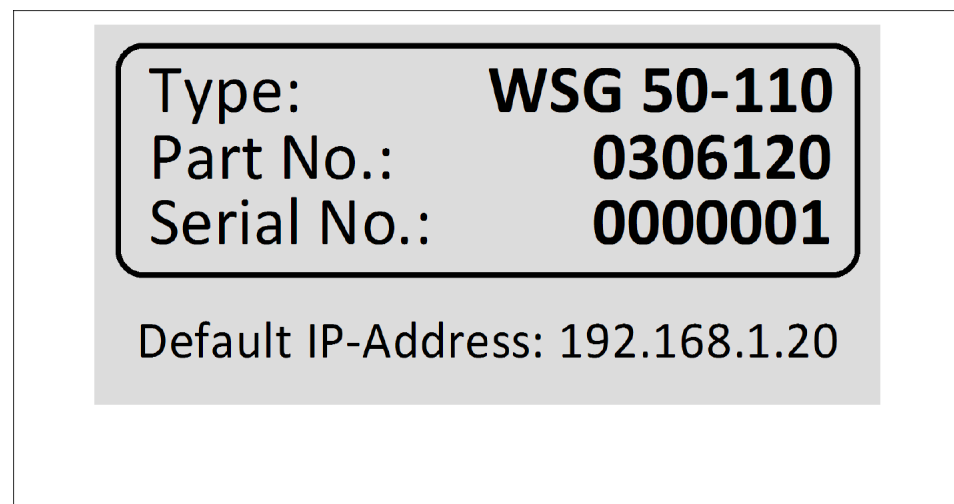

4 Design and description

4.1 Design

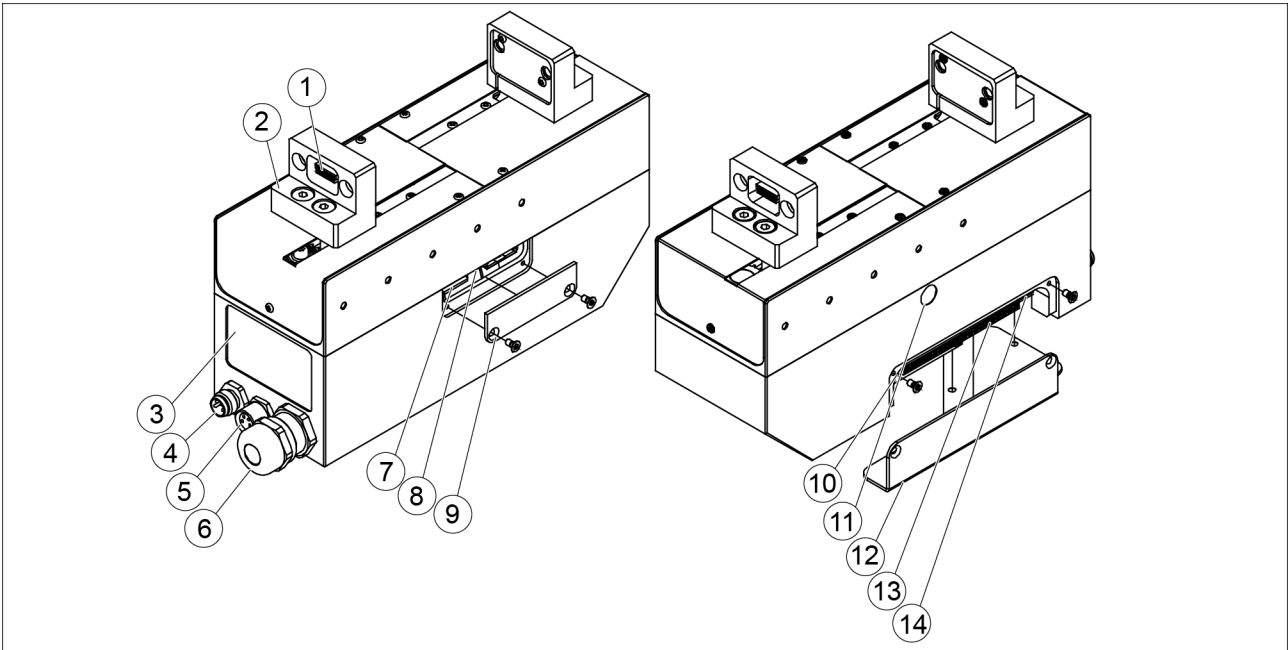

Components and connectors of the WSG 50

Item	Designation	Description / Hinweis
1	Sensor port	▶ 3.4.9 [27]
2	Base jaw	with standard sensor interface for gripper fingers with integrated sensors, direct detection and evaluation by gripper control system
3	Name plate	Information on name plate, ▶ 3.5 [29]
4	Connector for power supply and RS 232	▶ 3.4.6 [23]
5	Connector Ethernet	▶ 3.4.7 [24]
6	Cable gland	EMC-fitting, ▶ 3.4.2 [21]
7	Memory card	▶ 7.2 [41]
8	Communication-LEDs	▶ 7.4 [43]
9	Cover plate serviceinterface	
10	Switch for terminalbus	▶ 3.4.3 [22]
11	Display of the operating state	▶ 7.4 [43]
12	Cover plate terminal strip	
13	Terminal strip	Assignments, ▶ 3.4.1 [20]
14	Fuse	2A time lag, ▶ 3.4.4 [22]

4.2 Description

The product is a servo-electric parallel gripper. It is equipped with an integrated gripper control system that supports the following interfaces: Ethernet TCP/IP, RS 232, PROFIBUS DP, PROFINET (optional), Modbus/TCP (optional).

The previous illustration shows the connections and components of the product. The product is configured via a web interface and can be used with any standard browser. Furthermore, the product is equipped with a sensor port in the base jaws as standard. Gripper fingers with integrated sensor technology can be connected here, and can be directly evaluated by the gripper control. SCHUNK offers standardized fingers as accessories, which also work in direct coordination with the gripper controller. For more information, please contact SCHUNK.

5 Assembly

5.1 Safety notes



⚠ DANGER

Risk of fatal injury due to electric current!

Touching live parts poses an immediate risk of fatal injury by electrocution.

- Only allow a qualified electrician to perform work on electrical components.
- Prior to commencing work on electric components, restore to a de-energized state.
- In case of damage to the insulation, switch off the power supply immediately and arrange for a repair.
- Keep humidity away from live parts.



⚠ WARNING

Risk of injury due to unexpected movements!

If the power supply is switched on or residual energy remains in the system, components can move unexpectedly and cause serious injuries.

- Before starting any work on the product: Switch off the power supply and secure against restarting.
- Make sure, that no residual energy remains in the system.



⚠ WARNING

Risk of burns through contact with hot surfaces!

Surfaces of components can heat up severely during operation. Skin contact with hot surfaces causes severe burns to the skin.

- For all work in the vicinity of hot surfaces, wear safety gloves.
- Before carrying out any work, make sure that all surfaces have cooled down to the ambient temperature.

5.2 Mechanical connection

The threads and centering holes which can be used to mount the product are shown in the following figure.

The product has M3 and M6 threads for fixing on the rear of housing, as well as \varnothing 6 mm centering holes. The M6 threads together with the centering holes form part of the 50 mm ISO standard flange for industrial robots. When in holding mode, the

product constantly adjusts the gripping force, to ensure a constant gripping force. The surfaces which are screwed together must be capable of dissipating the resulting heat.

CAUTION

Risk of overheating!

- Please ensure that the thermal coupling is good, especially if the product is to apply high gripping forces over longer periods of time.
- Prevent exposure to external sources of heat, such as from your robot's pan-tilt unit, as this can reduce the product's performance.
- Poor dissipation of heat or exposure to additional heat will require the gripping force to be reduced.

NOTE

To ensure fault-free operation and to minimize the radiation of electromagnetic interference (EMC) the product's housing must be properly earthed.

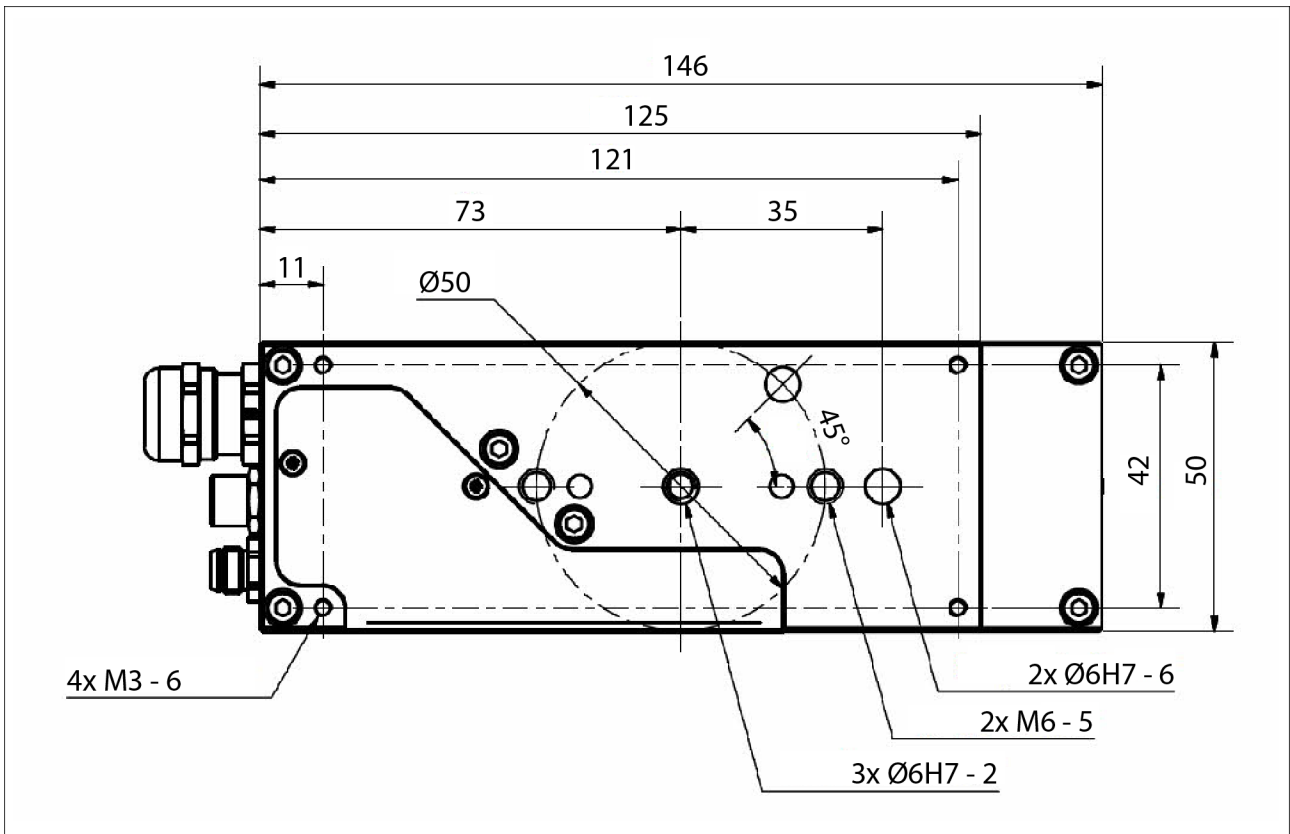

CAUTION

Material damage due to incorrect tightening torques!

Observe the maximum tightening torque:

- Screw M3: 1.0 Nm
- Screw M6: 3.0 Nm

5.3 Electrical connection

As supplied, the product is configured so that the M8 connector carries both the power as well as the logic parts for the integrated gripper control system. If your application requires the power and logic parts to be separated, for instance if you would like to use an external relay to ensure that the gripping force is safely switched off (cf. "safe torque off", STO), then the power and logic parts can be supplied separately (see Fig. "Equivalent circuit for the power supply"). The power and logic supply are not electrically isolated so they must use the same power supply unit (see Fig. "Connection type common supply to load and logic"). If the supply to the load is to be switchable in operation, then the connection can be arranged as shown in "Connection type supply to load separate from supply to logic".

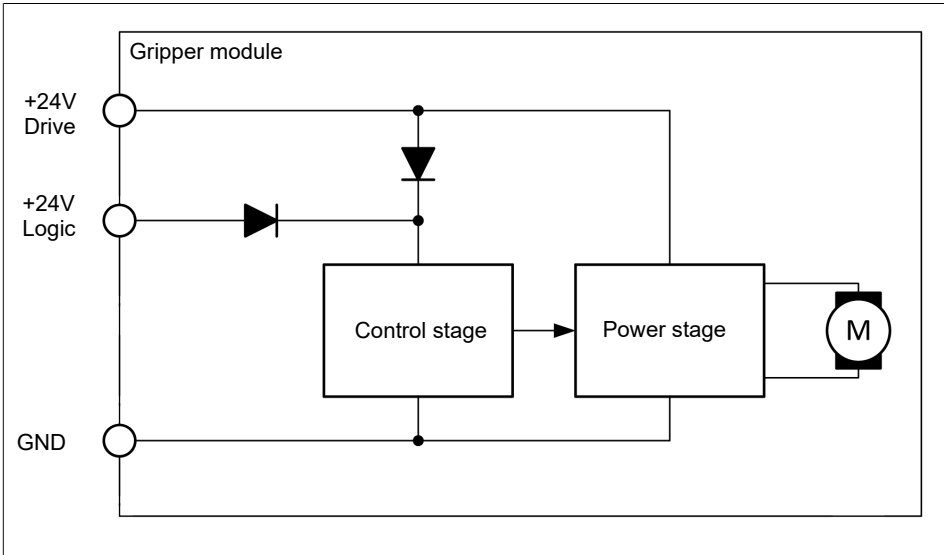

Equivalent circuit for the power supply

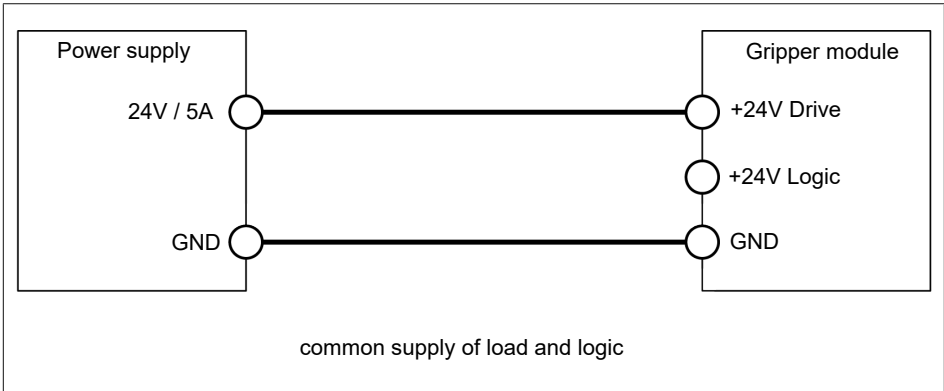

Connection type common supply to load and logic

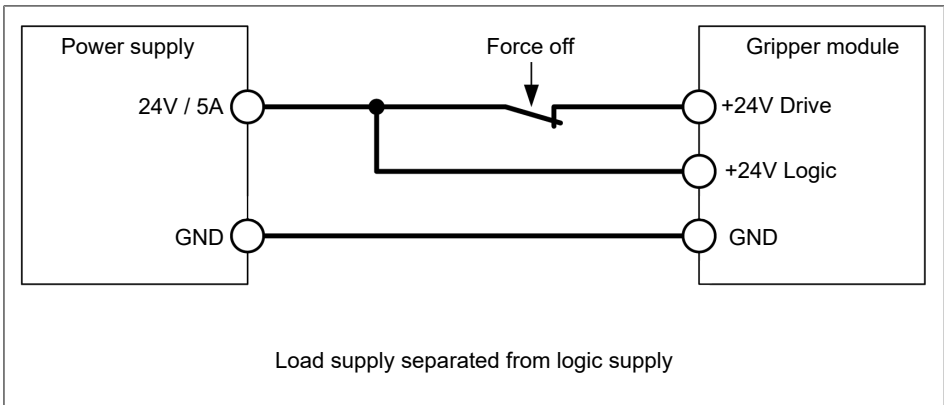

Connection type supply to load separate from supply to logic

NOTE
If load and logic are operated separately, always use the same power supply!

5.4 Installation of the fingers

To install the standard fingers, please use the fixing material supplied with the fingers. The centering sleeves supplied with the fingers must be used during the installation. This is particularly necessary if the finger has an electrical interface to the sensor port as otherwise the sensor port's connector can be damaged.

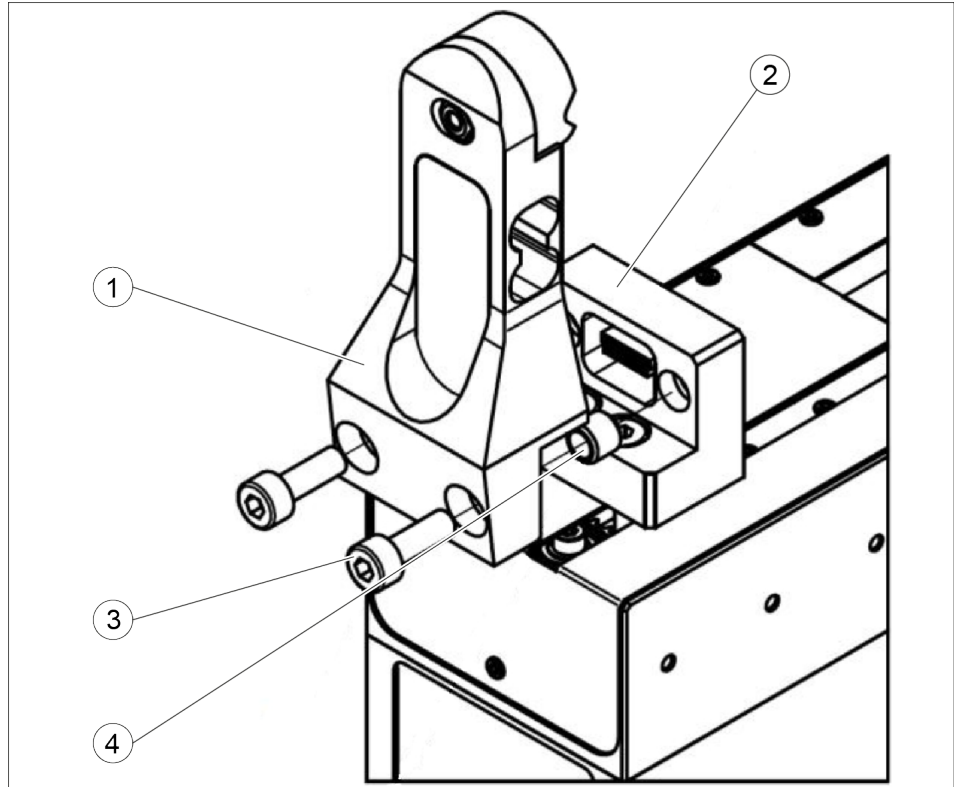

Installation of the fingers

1	Force measurement finger ABF WSG32/50-DV	2	Base jaw
3	Screw M4, ISO 4762	4	Centering sleeve

Tightening torque, max.: 2.5 Nm!

6 Start-up

6.1 Initial commissioning

NOTE

To ensure fault-free operation and to minimize the radiation of electromagnetic interference (EMC) the product's housing must be properly earthed.

When starting up the product for the first time, please follow the steps below:

1. Using the Ethernet/Power cable, connect the product to the existing Ethernet network or alternatively to the network card in your PC or laptop.
-

NOTE

- The product's IP address is factory-set to a static value of 192.168.1.20. Should you wish to operate several products in the same network and/or if this address is already in use, then you will have to change the product's IP address accordingly (e.g. set the 2nd product's IP address to 192.168.1.21). To do that, first connect the product directly to computer's network connection, to avoid address conflicts in the network. For more information about changing the IP address: ▶ 6.2 [□ 40]
 - To directly operate the product on your computer's network connection, you may have to alter your computer's network configuration. If in doubt, contact your system administrator.
-

2. Connect your product with the power supply (24 V, 3 A).
 - ⇒ The product will now start up. The indicator for the operating state will light up blue and after about 5 seconds it will start flashing quickly blue. This signals that the product is booting.
 - ⇒ After about 15 seconds the indicator will slowly flash white. The product is ready for use
3. On your computer, open the Internet browser and enter the address **<http://192.168.1.20>**.
 - ⇒ You will be presented with the product's configuration interface

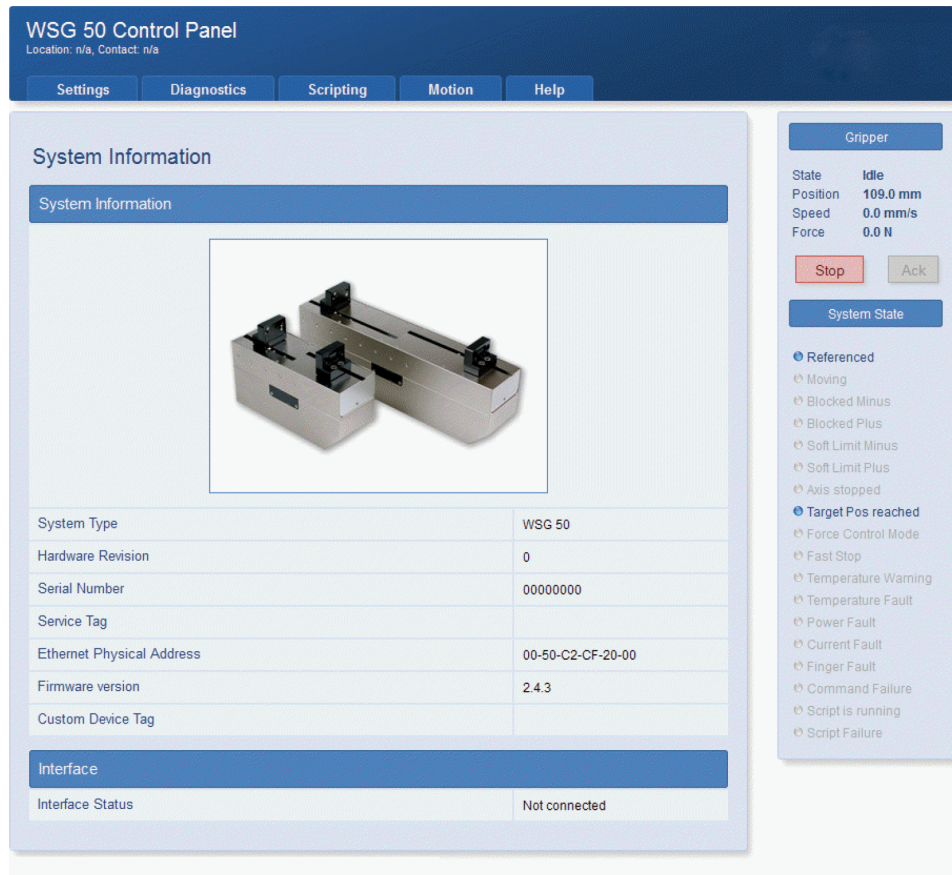

The starting page of the web-based interface

4. From the menu, select the *Motion* -> *Manual Control* option and click on the "Home" button
 - ⇒ The product will now zero itself.

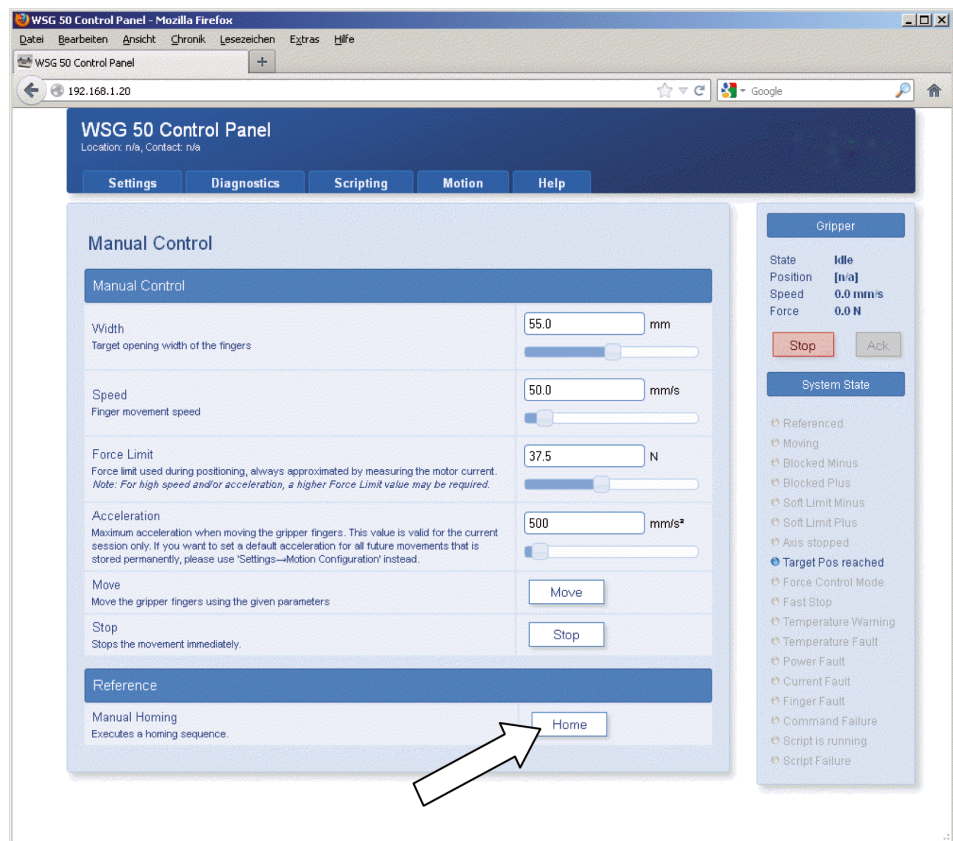

"Manual Control" configuration page

5. Once the homing sequence has been finished, for test purposes, you can move the product via the web interface. For this, select the movement parameters about the adjuster and then click on the "Move" button.

Important: The product must have been zeroed to be able to execute movement commands.

Other steps which you should take during the commissioning:

1. Call up the *Diagnostics* -> *System State* page, to check the product's supply voltage.
2. On the *Settings* -> *Command Interface* page, select the protocol on which your product is to be operated.
3. If necessary, on the *Settings* -> *Motion Configuration* page enable automatic homing during startup („Homing on Startup“)
4. On the *Settings* -> *System* page, create a user with corresponding rights and activate the web interface's security function, to prevent changes to your setting by unauthorized persons.

6.2 Changing the IP address and using DHCP

To change the product's IP address, in the web interface, select the *Settings* -> *Network* option menu. Adjust the IP address, subnet masks and any gateway or DNS server addresses for your local network and confirm the changes by clicking on the "Apply" button.

NOTE

After changing the network configuration you will have to restart the product.

To use addresses dynamically assigned via DHCP, check the corresponding box. In this case the product will automatically take its network configuration from a DHCP server.

NOTE

Please note that if you use DHCP to dynamically allocate IP addresses, there is no integrated way of finding out what IP address has been allocated. This is why the DHCP server should be configured so that the product is issued with an IP address which is known in advance

For further information, please contact your network administrator.

7 Operation

A high performance gripper control unit is integrated into the product. Access to the gripper control unit is possible by removing the cover with the SCHUNK logo.

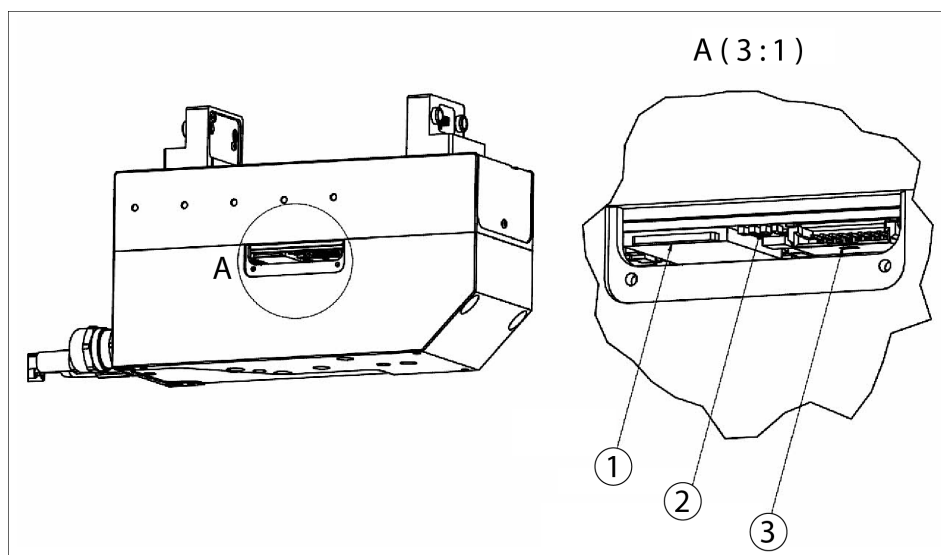

Opening to access the gripper control unit

1	Micro SD memory card	3	Test interface (For use only by Manufacturer)
2	Communication LEDs		

Via this opening you can see some other indicator LEDs as well as the control unit's memory card. The test interface is only used by the manufacturer for programming and test purposes and is not needed during the unit's production process.

7.1 Operating software

The software needed to operate the product is already installed in the unit.

NOTE

- To guarantee proper operation, the latest version of firmware should always be installed in the product.

⇒ The latest firmware can be obtained from the SCHUNK.

7.2 Memory card

The gripper control unit has a slot to insert a MicroSD memory card. Although all common variants are supported (SD and SDHC), we recommend the use of the following memory cards:

MicroSD card:

Made by: SANDISK, type: SDSDQM-002G-B35, capacity: 2 GB

The memory cards hold the following data:

- Software needed to operate the product
- Configuration data
- Documentation and software tools (can be called up via the web interface)
- Scripts and other user-specific data in the /user directory

The card installed by the manufacturer has a capacity of 2 GB. The required operating software is already installed on the card. User-specific data and scripts can be saved in the "user" subdirectory. Please do not change or delete any files outside of this directory as, otherwise, fault-free operation of the product can no longer be guaranteed.

NOTE

The memory card and the software which it contains are needed to operate the product. Should you wish to replace the memory card, please copy the contents of the original card onto the new one using a suitable card reader.

7.3 The boot process

The product has a boot loader, which loads and runs the unit's software from the memory card when the unit is powered up. The indicator for the operating state will light up blue during this. If there is an error, the indicator will light up red for 5 seconds. After this the boot loader will automatically be restarted. This will continue until the firmware can be loaded correctly.

If there is a VT100 compatible terminal connected to the serial interface, the boot loader prints a status messages to this interface and the indicator will turn to violett. The terminal adapter must be configured to 115200 bps, 8 data bits, no parity, 1 stop bit.

NOTE

To identify the terminal adapter, the module will output the byte sequence „ESC [?1;“ during startup with the interface settings described above. If using the serial interface as command interface, the host application must be configured in a way that doesn't cause any problems when receiveing this byte sequence.

7.4 Display of operating state

The product has a multi-colored indicator for the operating state. The current operating state is shown by both the color of the indicator as well as by the flash rate.

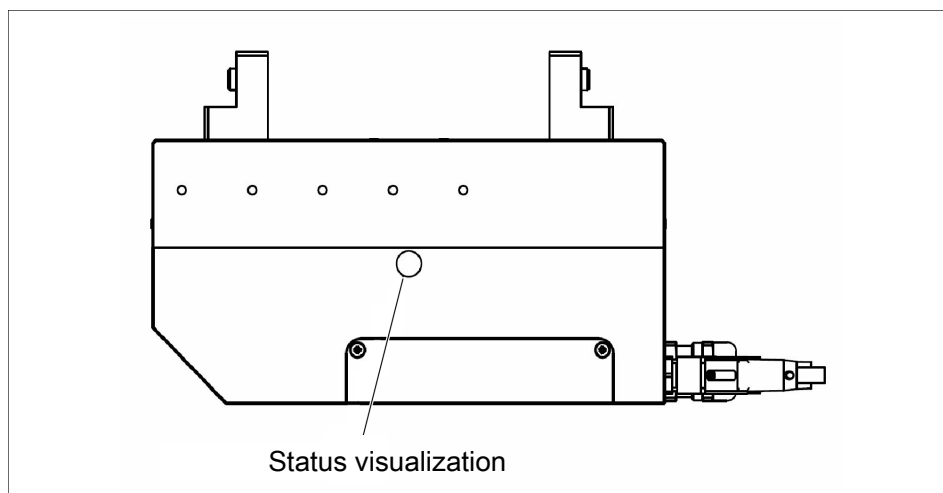

Display of operating state

The following operating states are indicated:

Status	Display
Loading the operating software The product loads the firmware and prepares for the launch.	Blue, constantly on
There was an error loading the operating software The boot process is automatically restarted.	Red for about 5 seconds, then blue again
Boot process for the operating software The operating software will be started and the control system will be configured.	Blue, flashing
Wait state The product is ready for operation and waiting for a command.	White, slowly pulsating
Busy The product is in the initialization phase or is executing a command.	White, quickly pulsating
Not available	Green, quickly pulsating
Warning One or more parameters have reached warning limits. Check the system's status via the web interface.	Yellow, quickly pulsating
Command received with no errors The product has received an error-free command.	Green, pulses once
Error carrying out a command An error has occurred while receiving or executing a command.	Red, pulses once
Critical fault	Red, pulses quickly

Status	Display
--------	---------

An error has occurred (e.g. excess temperature, loss of communication, etc.) The error must be acknowledged before the product can process new motion commands.

Critical software fault

A serious exception error has occurred and the execution of the software in the device has been stopped. The product starts again after a short period of time.

Red, flash code: 2x short, long break

More LEDs indicating SD card and communication activity can be found next to the SD card slot under the cover plate with the SCHUNK logo.

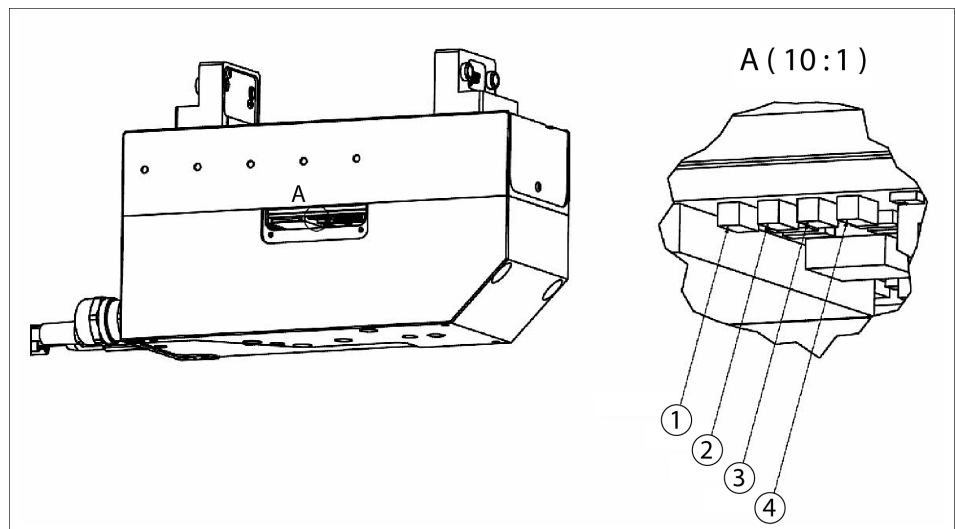

Communication LEDs

1	SD access	3	not assigned
2	Profibus	4	Ethernet

A constant lighting of the respective LED indicates that the interface is active. The LEDs flash in the rhythm of the interface activity or data traffic.

7.5 Status word and gripper state

The product's current state can be called up at any time via the status word and the gripper state.

7.5.1 Status word

The current state of the product is summarized in the so-called status word. This can be read out via the command interface (using the command: Get System State, 40h), via the web interface or via a script (using the command: Read System State flags, gripper.state()). Following figure shows the display of the status word via the side bar in the web interface. The status

word includes both pure status messages (e.g. zeroed, execution of script, etc.) as well as warnings and errors (e.g. temperature warning, power failure, etc.).

NOTE

You will find the documentation for the status word in the manual “WSG Command Set Reference”

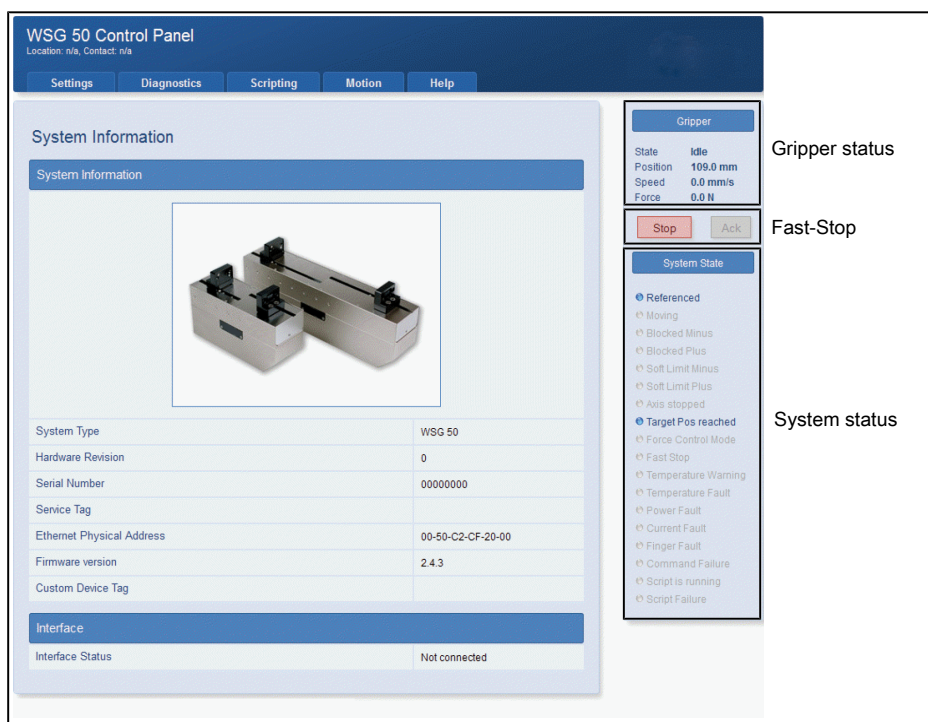

Web Interface side bar with system state

7.5.2 Gripper state

The gripper state reflects the current state of the gripper and is used to control the process of gripping. It can take the following states:

State	Description
IDLE	The gripper is in its idle state No gripping process is currently in progress
GRIPPING	The gripper is closing A part is being gripped, the fingers are moving towards the part. The detection of gripped items is active.
HOLDING	A part is being held A part is being held with the configured force. The monitoring of the gripped part has been activated.
PART LOST	A part has been lost

State	Description
	The pre-configured gripping force can no longer be applied, presumably because the part to be gripped has been lost.
NO PART FOUND	<p>No part has been found</p> <p>When closing the gripper at the configured position, no part was found to be gripped.</p>
RELEASING	<p>The gripper is opening</p> <p>The gripped part is being released, the fingers are moving.</p>
POSITIONING	<p>Pre-positioning</p> <p>The gripper is being pre-positioned and the fingers are moving.</p>
ERROR	<p>Error</p> <p>An error occurred carrying out the last command. For errors which require acknowledgment, the SF_FAST_STOP flag is also set in the system status word.</p> <p>After any acknowledgment required, the movement can be restarted.</p>

NOTE

The gripper's state does not indicate whether the gripper is referenced or not. Instead, the system state flags (SF_REFERENCED) must be read to check this.

The gripper's state is shown like the status word in the side bar of the web interface. The following diagram shows the possible transitions between the gripper's states.

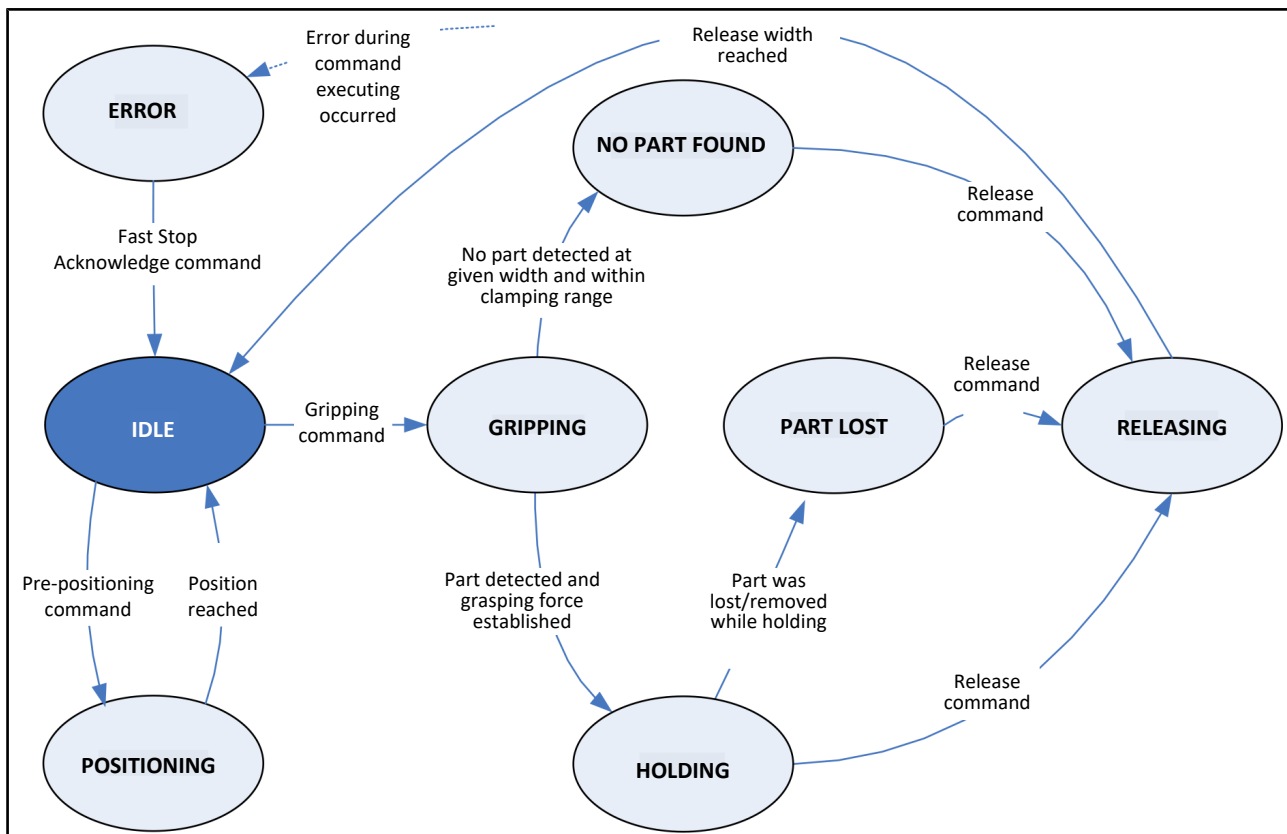

Transitions between the gripping states

Stop command: Issuing a Stop command in any state (except ERROR) will abort the current action and immediately return to IDLE state.

7.6 Homing the product

To detect the product's position, it is equipped with a measuring system which can detect the finger's spatial location at a high resolution. Due to the incremental method of position detection, the product has to be homed before motion commands can be executed.

The product has a special command for homing which can be issued via the command interface, by a script or via the web interface. It then moves its fingers to the inner or outer physical limit and saves the measured position as a reference value. To offer maximum flexibility, the product can be referenced to the inner as well as to the outer limit. For outer homing, a factory-calibrated value is used to shift the reference position, so that both variants end up with the same direction and the same origin for the axis coordinates.

NOTE

- Make sure that the fingers can actually move freely in the reference drive direction up to the product's mechanical limit.
 - The homing movement should be carried out in the direction of the required positioning accuracy.
 - To automatically execute a homing sequence on start up, activate the "Homing on Start up" option via the web interface *Settings -> Motion Configuration*).
-

7.7 Gripping, detecting parts to be gripped and monitoring the gripping

The product is equipped with an integrated detector for parts to be gripped and a grip monitor, which allows reliable handling even for difficult parts without the use of external sensors. To configure these functions, the following parameters are available on the web interface *Settings -> Motion Configuration*:

Parameter	Description
Part Width Tolerance ("Part Width Tolerance")	The tolerance of the specified nominal gripper width which is sent to the product with the grasp command. This is measured as the relative gap between two fingers moving towards one another.
Clamping travel ("Clamping Travel")	If a part to be gripped has been detected, the product will attempt to apply the required gripping force by moving the fingers within this range. This is measured as the relative gap between two fingers moving towards one another.

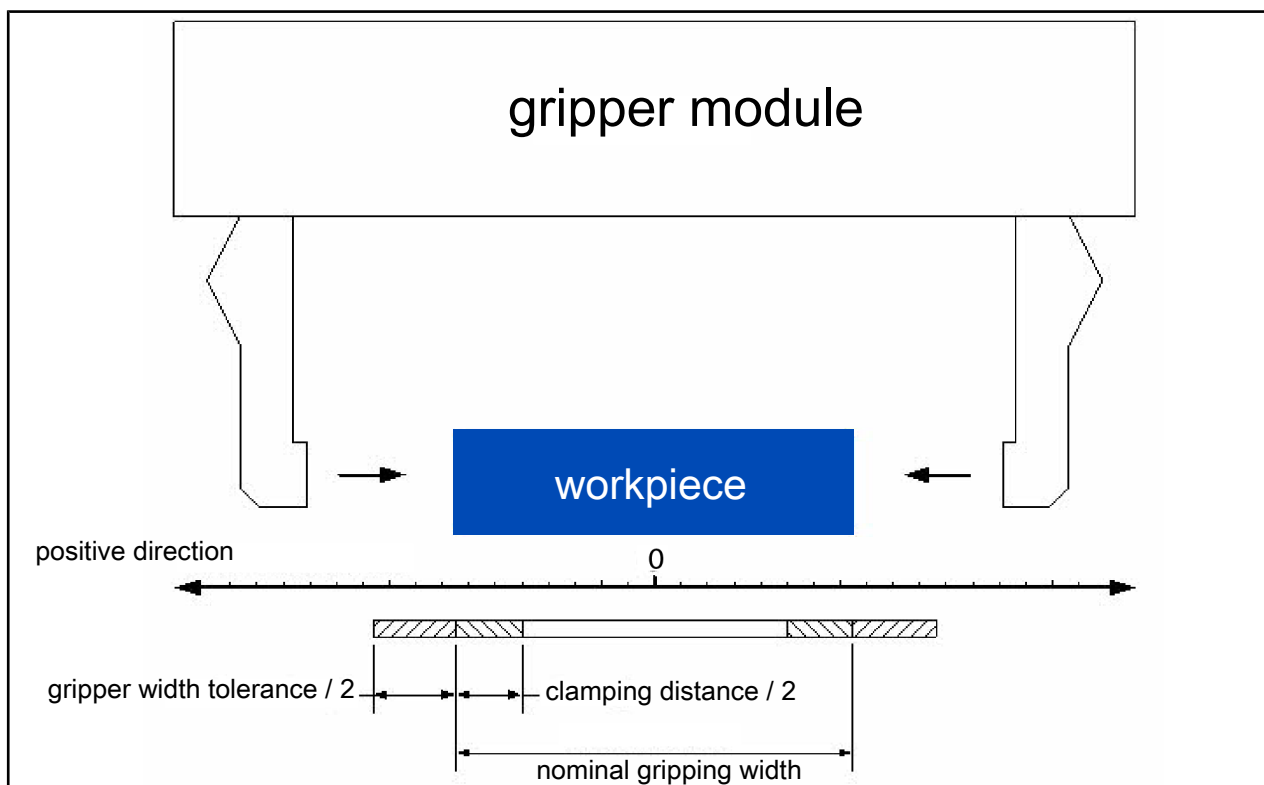

Parameters defining a grip

The figure clarifies the function of these two parameters. A grip is only valid (which means it doesn't create an error) if the detected width of the part lies within the hatched area consisting of the part width tolerance and the clamping travel. If no part is detected, then the gripper state will change to "NO PART FOUND". If a contact is detected outside of the defined range, this will be detected as an axis block and the gripper's state will change to "ERROR".

NOTE

The detector of parts to be gripped and the grip monitoring are not running in pre-position mode ("Pre-position" command).

CAUTION

Material damage due to insufficient lubrication!

In the case of long-term short travel, it is possible to dry the product.

- Every 1000 movements or at least once per day the product should be moved through its full range of travel.

NOTE

- For soft parts to be gripped, it may be necessary to increase the clamping travel.
- Setting the part width tolerance to the full range of movement of the product (maximum settings) will deactivate the detection of axis blocking when gripping.

7.8 Software limit switch

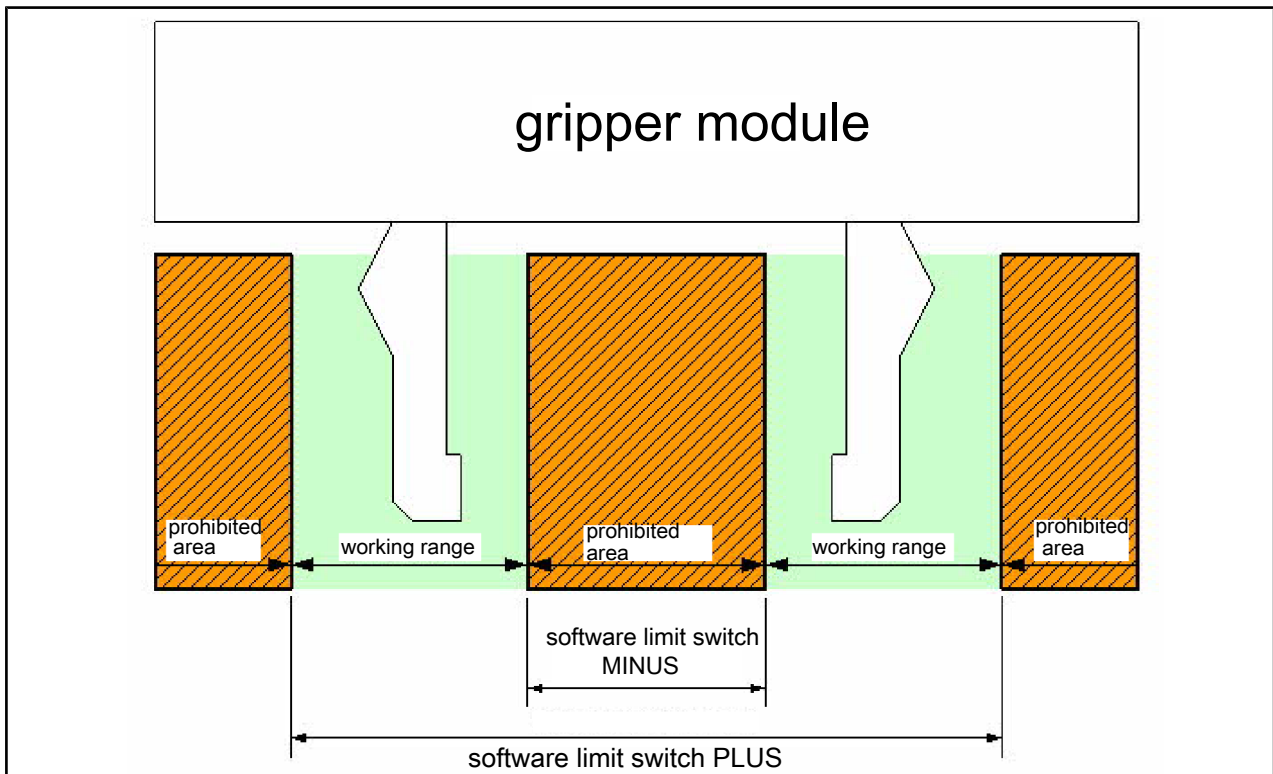

Software limit switch

The product's travel can be limited via the software limit switch. There is one limit switch for an inner range ("MINUS") and one for an outer range ("PLUS"). If the software limit switches have been activated, then positioning commands to move fingers into this range will get a range error response and the command will not be executed. There is also protection from crossing the edges of these ranges. The monitoring will trigger a fast stop which requires acknowledgment if the fingers should be moved into these areas.

The software limits can be set via the command interface, a script or the web interface (*Settings -> Motion Configuration*).



⚠ WARNING

These software limits do not represent a safety function as understood by the machine directive!

CAUTION

The software limit switches are always related to the reference position of the base jaws. Bodies on the base jaws or on the gripper jaws are not included!

NOTE

- If the fingers are within the forbidden area when the software limit switches are activated, then only movements to leave this area will be possible.
- More information on this subject are in the manuals "WSG Command Set Reference Manual" and "WSG Scripting Reference Manual".

7.9 Fast stops requiring acknowledgment

The product offers a so-called Fast Stop to put the product into a defined state in case of an error or malfunction. Fast Stops are displayed by setting the SF_FAST_STOP flag in the status word. If a fast stop is triggered, for example due to an insufficient voltage error, then all movement commands will be rejected until the error is acknowledged and any fault condition has been cleared, with corresponding error codes being returned (access denied). If the product is in Fast Stop state, power will be removed from the drives but the position reference will be retained.

The error can be acknowledged both via the command interface (the command is: Acknowledging a Fast Stop or fault Condition, 24h) as well as manually by clicking on the "Ack" button in the side bar of the web interface ▶ [7.5.1 \[44 \]](#).

Fast stops are recorded in the product's event log ▶ [7.10 \[52 \]](#).



⚠ WARNING

Loss of gripping power on fast stop!

Workpieces can fall down and cause serious injury.

The fast stop does not represent a safety function as understood by the machine directive.

NOTE

A fast stop can also be triggered via the command interface, by a script or manually via the web interface.

NOTE

More information on this subject are in the manuals "WSG Command Set Reference Manual" and "WSG Scripting Reference Manual".

7.10 Log memory

The product has a non-volatile log memory in which important events can be recorded. The events can be saved with a timestamp and they are sorted in chronological order. If no time of day is available via the network, then the time in milliseconds since the system was started will be used. When the memory is full, the oldest events will be overwritten. The log memory can be read out via the web interface (*Diagnostics ->System State*). For diagnostic purposes, it can also be copied to the internal SD card and can be downloaded via the file manager integrated in the web interface:

1. Open the web interface.
2. Go to *Diagnostics -> System Information*.
3. Click on the "Dump" button underneath the log.
 - ⇒ A file "logfile.txt" will be created in the user directory on the SD card.
4. Download the file using the file manager. To do that, select "File Manager" in the in the menu "Scripting". Click on the

file and start the download via the button. 

7.11 Thermal monitoring

To protect the product from overheating, its housing is constantly monitored during operation. The current housing temperature can be checked both via the web interface as well as the command interface.

If the temperature measured exceeds the limit of 65 °C, then a temperature warning will be issued. From a housing temperature of 70 °C the product will change into temperature error mode and will switch the power output stage off via a fast stop. This temperature error must be acknowledged via the "Fast Stop

Acknowledge" command.

Temperature warnings and errors are recorded in the product's event log memory ▶ 7.10 [52].



⚠ WARNING

Loss of gripping force on temperature error!

Workpieces can fall down and cause serious injury.

NOTE

- This error can only be acknowledged if there is no longer a temperature error.
- The command to read out the current housing temperature and the command to acknowledge the Fast Stop via the command interface are documented in the "WSG Command Set Reference Manual".

7.12 Monitoring the motor current

The drive current is continuously measured and monitored during operation. An integrated motor model is used to check whether the drive is being overloaded or not. In this case, the power output stage will be switched off via a fast stop and a "current fault" will be displayed. The current error must be acknowledged. This can either be done via the web interface or via the command interface using the "Fast Stop Acknowledge" command.

Current errors are recorded in the product's event log ▶ 7.10 [52].



⚠ WARNING

Loss of gripping force when there is a current error!

Workpieces can fall down and cause serious injury.

NOTE

- This error can only be acknowledged if there is no longer a current error.
- For the documentation of the command to acknowledge the "Fast Stop" via the command interface, see the "WSG Command Set Reference Manual".

7.13 Monitoring the supply voltage

To ensure the correct functioning of the product, the supply voltage to its power section is continuously monitored. If this is outside a defined range, a warning or an error will be issued. The following limits apply:

Threshold	Consequence
$V_{DRIVE} \leq 20 \text{ V}$	Low voltage fault SF_POWER_FAULT will be set in the system's status word and the status indicator will show the error state.
$V_{DRIVE} \leq 22 \text{ V}$	Low voltage warning SF_POWER_WARNING will be set in the system's status word and the status indicator will show the warning state.
$V_{DRIVE} \geq 26 \text{ V}$	Excess voltage warning SF_POWER_WARNING will be set in the system's status word and the status indicator will show the warning state.
$V_{DRIVE} \geq 28 \text{ V}$	Excess voltage error SF_POWER_FAULT will be set in the system's status word and the status indicator will show the error state.

Hysteresis is used to prevent the states chattering to and fro. If there is a voltage error, the power output stage will be switched off using a fast stop and a voltage error will be indicated. This must be acknowledged, but will only be possible when the operating voltage is back in its permissible range. You can do this either via the web interface or via the command interface via the "Fast Stop Acknowledge" command.



⚠ WARNING

Loss of gripper power following an error due to the voltage being too high or too low!

Workpieces can fall down and cause serious injury.

NOTE

- The low voltage fault will also be triggered if the power supply is interrupted when switching the force off, e.g. via an emergency stop relay.
- This error can only be acknowledged when there is no longer a high/low voltage error.
- Further information of the system status word and of the command to acknowledge the "Fast Stop" via the command interface, see the "WSG Command Set Reference Manual".

7.14 Overdrive mode

The product is equipped with an overdrive mode, in which for grasping cycles with short holding times (max. 2 seconds) and long opening times (more than 10 seconds) grasping forces higher than the nominal grasping force can be achieved. The overdrive mode must be activated using a special command on the command interface and will be displayed in the system state („Overdrive Mode“).

Activating the overdrive mode will be noted in the system log ▶ 7.10 [52].

CAUTION

Despite to thermal protection, the product can be damaged when overloading. For further information, please contact our technical distributor.

NOTE

For a documentation of the overdrive mode, please check the „WSG Command Set Reference Manual“.

7.15 Configuration and diagnosis via the web interface

The product has an integrated web server, with an user interface for configuration and diagnosis. To use this, the product must be connected via Ethernet. To get to the configuration user interface, open a browser and enter the product's IP address (on delivery this is 192.168.1.20) into the browser's address line:

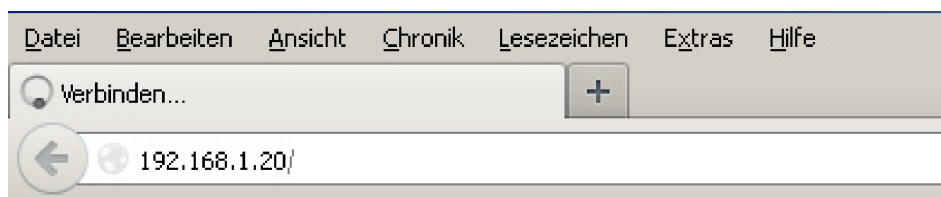

Entering the IP address to start web-based configuration

The following browsers have been tested and support the product's web interface:

- Mozilla Firefox 16 and above
- Google Chrome 23 and above
- Apple Safari 5 and above
- Mobile Safari (iOS 4.3 and above)
- Internet Explorer 8 and above

NOTE

To display the web user interface, JavaScript must be enabled in your browser.

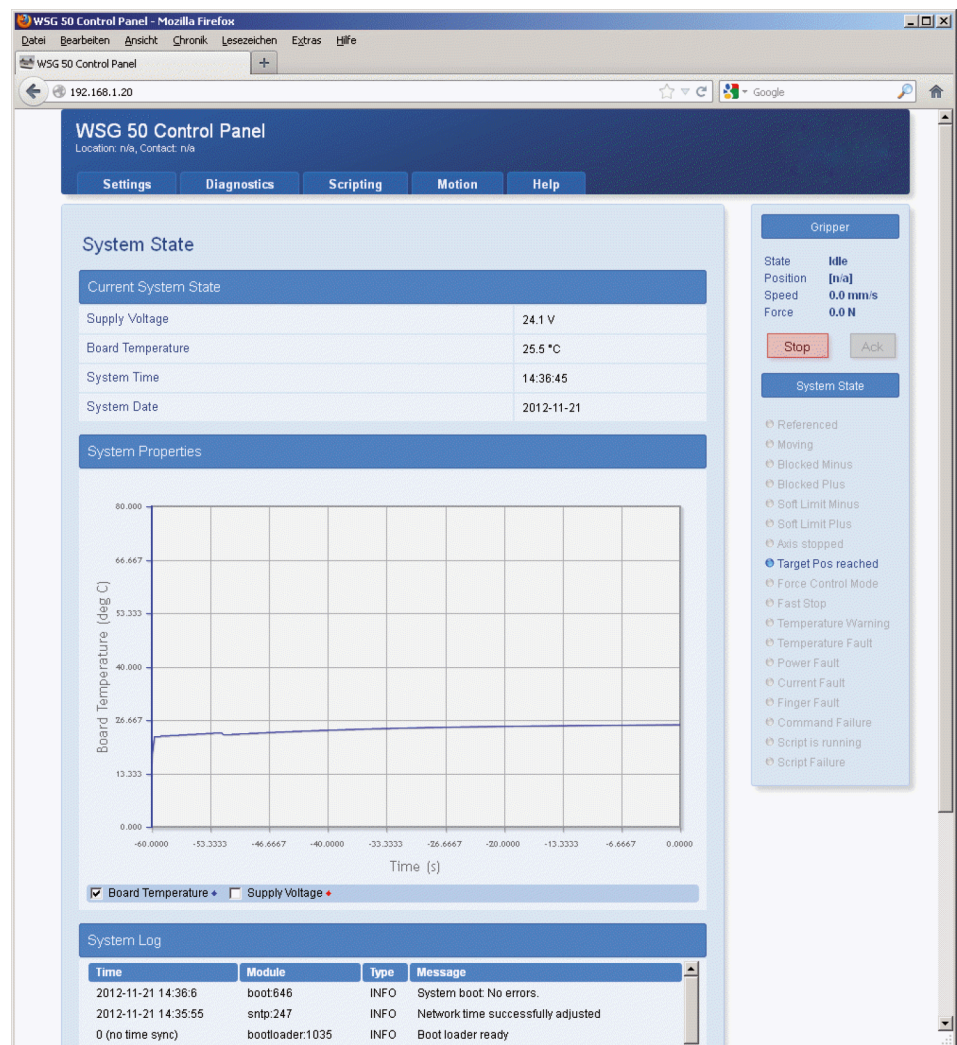

Web interface for configuration and diagnosis

Via integrated help texts, the product's web interface is intuitive to use. In the upper area you will find a menu bar via which the individual pages can be called up.

7.15.1 Access restrictions for the web user interface

Depending on the network configuration, the product will be visible to everyone in the entire network and the configuration can thus be altered unchecked.

To restrict access to the product's web interface, under *Settings* -> *System Configuration* you can activate access restrictions for the interface and create users with differing access rights.

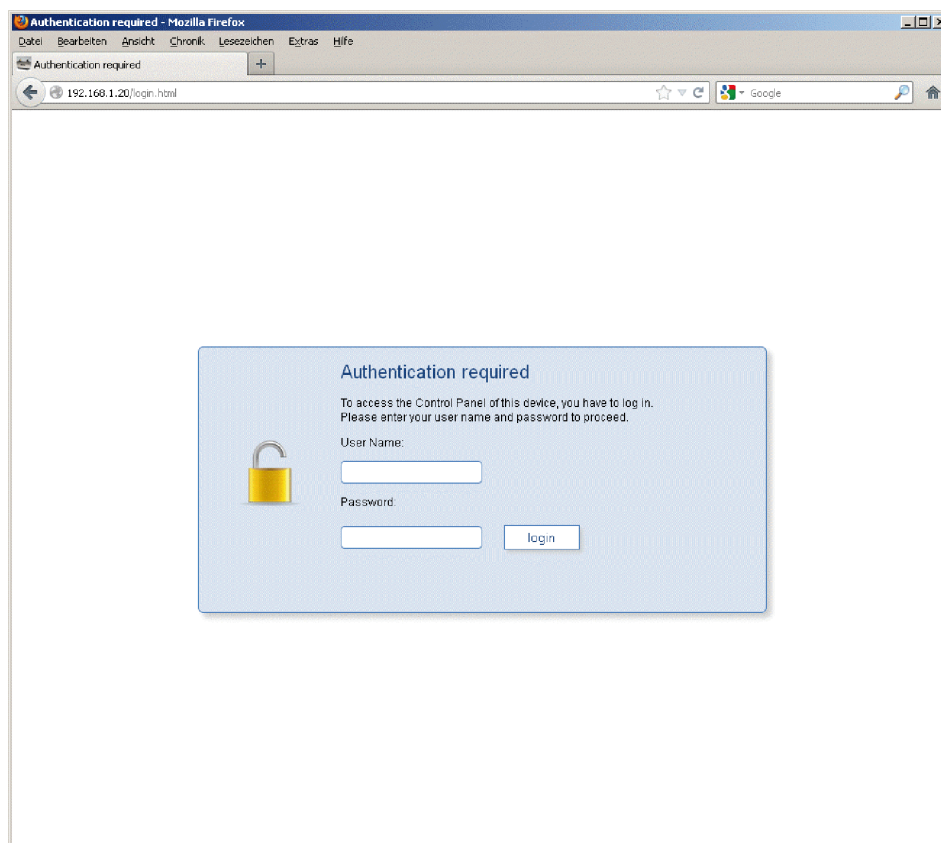

Login screen

If this is activated, each user must be identified with a login name and personal password.

Every user is assigned to one of the following user groups:

- **User**
Standard user: Cannot adjust settings, but can only access the pages under the menu options "Diagnostics" and "Help".
- **Administrator**
Administrator: Can adjust all of the product's settings without restriction.

NOTE

If access restrictions have been activated, then the product will record which user logs in and when.

7.16 Command interface

The product supports the control system via RS 232, TCP/IP, UDP, PROFIBUS, PROFINET (optional) and Modbus/TCP (optional). TCP/IP and UDP can be used to communicate with a text-based communication protocol (Gripper Command Language - GCL), which is specified in the document "GCL Reference Manual". The interface RS 232 supports a binary communication protocol, which is described in detail in the document "WSG Command Set Reference".

The binary protocol can also be used via TCP/IP and UDP. For control via the PROFIBUS, PROFINET and Modbus/TCP fieldbus interfaces, a DPv0-compatible input/output area is available, which can be used to control the product by setting discrete values and to read the current product parameters. For details, refer to the "WSG Fieldbus Interface Documentation".

The command interface is selected and configured via the product's web interface, via the menu option *Settings* -> *Command Interface*.

7.17 Scripting

The product includes an integrated interpreter for the Lua programming language, via which you can adapt the product's software to your application. The programs (scripts) are saved on the integrated memory card and can be run automatically when the product starts. The interpreter is configured via the web interface. You will find the reference information for the commands as well as notes about creating and using scripts in the document "WSG Scripting Reference Manual".

7.18 Resetting the configuration

Via the "Settings → System" page, the product's configuration can be reset to its state on delivery. Should the configuration interface no longer be accessible, for example if the network configuration is faulty or if you have forgotten your password, you can restore the state on delivery by renaming the file "config\system.cfg" to "config\system.old".

CAUTION

Manually editing the configuration file can lead to unwanted behavior.

7.19 Implementing the gripping process

In the following section, the steps are described which are needed for a simple handling cycle (preposition – grip – release). The specified commands relate to the command interface. You will find a detailed description of the commands and parameters in the "WSG Command Set Reference Manual".

Preparatory work:

1. Adjust the "Clamping Travel" and "Part Width Tolerance" to the application.

Description: ▶ 7.7 [48]

2. Perform a test grip.

You can do this for example via the web interface, menu option *Motion* -> *Grasping*

Executing the gripping cycle:

1. Check whether the gripper has been zeroed (optional)

If not, run the command "Homing (20h)" and wait until SF_REFERENCED is set in the status word. Request the status word with the command "Get System State (40h)". Error? then error handling.

2. Pre-position finger

Execute the command "Pre-Position Fingers (21h)".

Parameters: Opening width and speed. The gripper state changes to "POSITIONING". Wait until the gripper state is "IDLE". Request the gripper state with the command "Get Gripping State (41h)".

3. Execute the grip

Command "Grasp Part (25h)". Parameters: Nominal gripping width, gripping speed, gripping force. The gripper state changes to "GRIPPING". Wait until the gripper state is "HOLDING". Deal with errors if gripper state is "NO PART FOUND" or "ERROR".

4. Handling the part

Periodically request the gripper state and check whether it is still "HOLDING". Deal with errors for "PART LOST" or "ERROR". The periodical requests will not be required if spontaneous messages (see "WSG Command Set Reference Manual") have been activated.

5. Releasing the part

Command "Release Part (26h)". Parameters: Opening width, speed. The gripper state changes to "RELEASING". Wait until the gripper state is "IDLE". Deal with errors on "ERROR".

6. Start again at 2.

Dealing with errors

What to do in case of an error actually depends a lot on the application, but in general requires the user to do something. The following section gives some hints:

- 1. Does the returned status code differ from E_SUCCESS?**
Evaluate the returned status code and eventually request user intervention.
- 2. Gripper status „ERROR“**
Request user intervention. Also: Test whether SF_FAST_STOP is set in the status word. If it is, then request acknowledgment.
- 3. Gripper status „NO PART FOUND“**
Depending on the task, jump over the processing and fetch a new part.
- 4. Gripper status „PART LOST“**
Part lost. If necessary, abort processing and fetch new part or request user intervention.

NOTE

- For the implementation of gripping processes via PROFINET and Modbus / TCP see instructions "WSG Documentation of fieldbus interface".
 - Gripper cycles can also be mapped via a script. For this purpose, please see the "WSG Scripting Reference Manual".
-

CAUTION

Material damage due to insufficient lubrication!

In the case of long-term short travel, it is possible to dry the product.

- Every 1000 movements or at least once per day the product should be moved through its full range of travel.
-

8 Maintenance and cleaning

The maintenance and lubrication intervals must be adapted to the ambient and operating conditions. The following factors should be taken into account here:

- Extreme operating temperatures
- The effects of condensation
- High vibration loading
- Use in a vacuum
- Very dynamic operation
- The effect of foreign substances (e.g. steam, acids, etc.)

Clean the product at regular intervals with a dry cloth to remove all soiling and metal chips. These typically collect in the depressions, on the linear guides for the base jaws and on the edges of the housing.

CAUTION

Material damage due to insufficient lubrication!

In the case of long-term short travel, it is possible to dry the product.

- Every 1000 movements or at least once per day the product should be moved through its full range of travel.
-

9 Troubleshooting

9.1 The gripper jaws don't move

Possible cause	Corrective action
Base jaws jam in housing, e.g. mounting surface is not sufficiently even.	Check the evenness of the mounting surface. Loosen the mounting screws of the product and actuate the product again.
A component is broken e.g. due to overloading.	Replace component or send it to SCHUNK for repair. Make sure that the product was only used in the context of its defined application parameters.
Operating voltage is not sufficient.	Check the power supply. Check requirements on power supply.
Communication not possible.	Check the connections and communications cables. interface addressing. Check (e.g. IP address, Profibus station address) Check the connection parameters.
Error message in the system (LEDs on the product are lamping yellow or red).	Check operating state of the product.

9.2 Gripper stops abruptly

Possible cause	Corrective action
Supply voltage is not connected.	Check the power supply.
Communication not possible.	Check the connections and communications cables.
Fast stop	Check the status of the gripper control system. Determine the cause of the fast stop and remedy if necessary. Acknowledge the fast stop, Fast stops requiring acknowledgment
Error message in the system (the operating state indicators of the product illuminate yellow or red)	Check operating state of the product.

9.3 No connection to the web interface

Possible cause	Corrective action
Supply voltage is not connected.	Check the power supply.
Communication not possible.	Check the connections and communications cables. Check network settings on the product. Check network settings on the computer.

10 Translation of the original declaration of incorporation

in terms of the Directive 2006/42/EG, Annex II, Part 1 Section B.

Manufacturer/
Distributor SCHUNK SE & Co. KG
Spanntechnik | Greiftechnik | Automatisierungstechnik
Bahnhofstr. 106 – 134
D-74348 Lauffen/Neckar

We hereby declare that the partly completed machine described below

Product designation: Servo-electric 2-finger parallel gripper / WSG 50 /electric
ID number 0306120

meets the following basic occupational health and safety of the Machinery Directive 2006/42/EC:

No. 1.1.1, No. 1.1.2, No. 1.1.3, No. 1.1.5, No. 1.3.2, No. 1.5.1, No. 1.5.2; No. 1.5.4, No. 1.5.6, No. 1.5.8, No. 1.5.10, No. 1.5.11, No. 1.5.13

The partly completed machinery may not be put into operation until it has been confirmed that the machine into which the partly completed machinery is to be installed complies with the provisions of the Machinery Directive (2006/42/EC). The declaration shall be rendered invalid if modifications are made to the product.

Applied harmonized standards, especially:

EN ISO 12100:2010 Safety of machinery – General principles for design –
Risk assessment and risk reduction

The special technical documentation according to Annex VII, Part B, belonging to the partly completed machine, has been created.

Person authorized to compile the technical documentation:
Stefanie Walter, Address: see manufacturer's address

Signature: see original declaration

Lauffen/Neckar, May 2024

Dr.-Ing. Manuel Baumeister,
Head of Systems Engineering,
Technology & Innovation

11 Information on the RoHS Directive, REACH Regulation and Substances of Very High Concern (SVHC)

RoHS Directive

SCHUNK products are classified as "large-scale stationary installations" or as "large-scale stationary industrial tools" within the meaning of Directive 2011/65/EU and its extension 2015/863/EU "on the restriction of the use of certain hazardous substances in electrical and electronic equipment (RoHS)", or fulfill their intended function only as part of one. Therefore products from SCHUNK do not fall within the scope of the directive at this time.

REACH Regulation

Products from SCHUNK fully comply with the regulations of Regulation (EC) No. 1907/2006 "concerning the Registration, Evaluation, Authorization and Restriction of Chemicals (REACH)" and its amendment 2022/477. SCHUNK attaches great importance to completely avoiding chemicals of concern to humans and the environment wherever possible.

Only in rare exceptional cases do SCHUNK products contain SVHC substances on the candidate list with a mass content above 0.1%. In accordance with Article. 33 (1) of Regulation (EC) No. 1907/2006, SCHUNK complies with its duty to "communicate information on substances in articles" and lists the components concerned and the substances used in an overview that can be viewed at [schunk.com/SVHC](https://www.schunk.com/SVHC).

Signature: see original declaration

Lauffen/Neckar, May 2024

Dr.-Ing. Manuel Baumeister,
Head of Systems Engineering,
Technology & Innovation

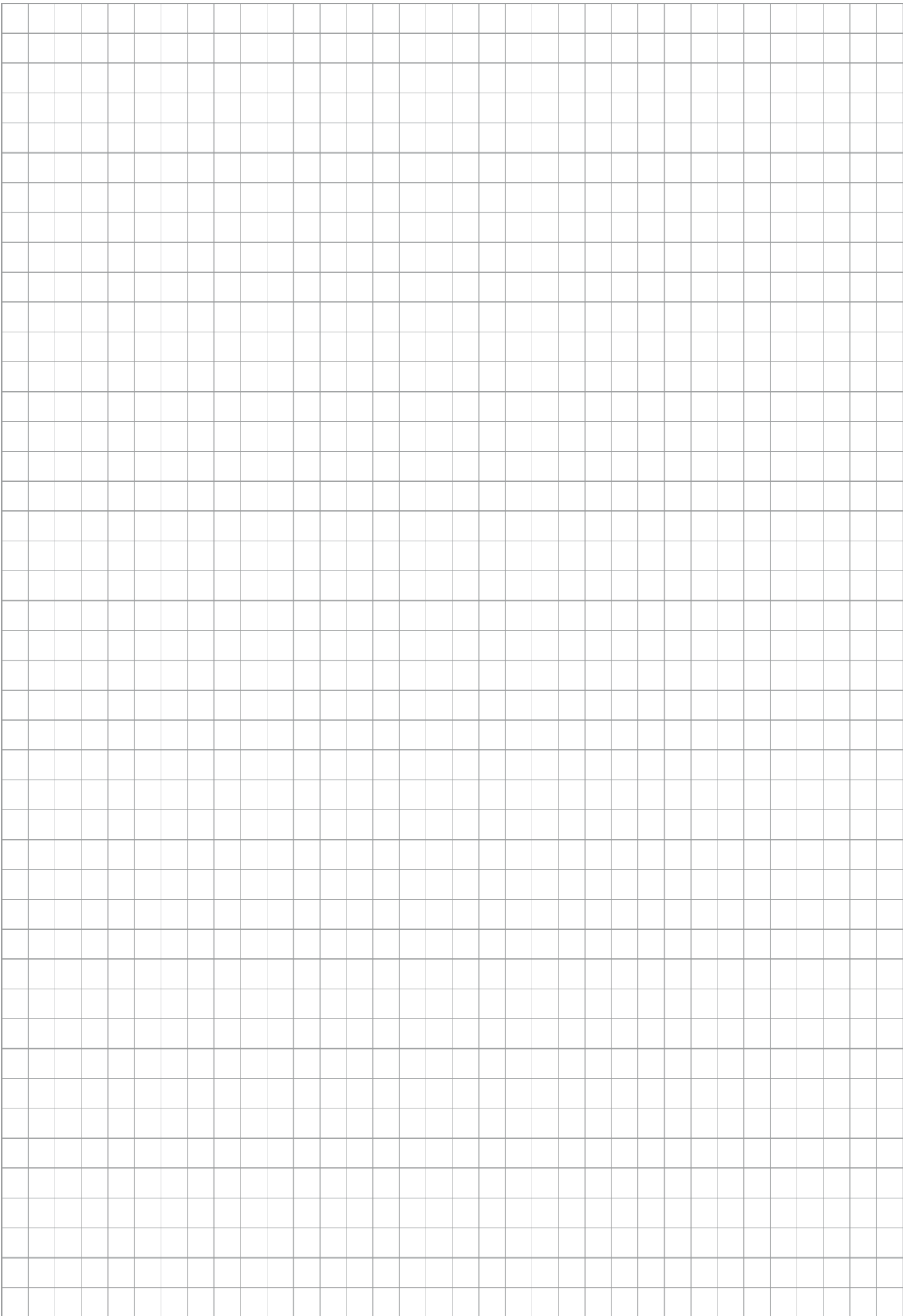

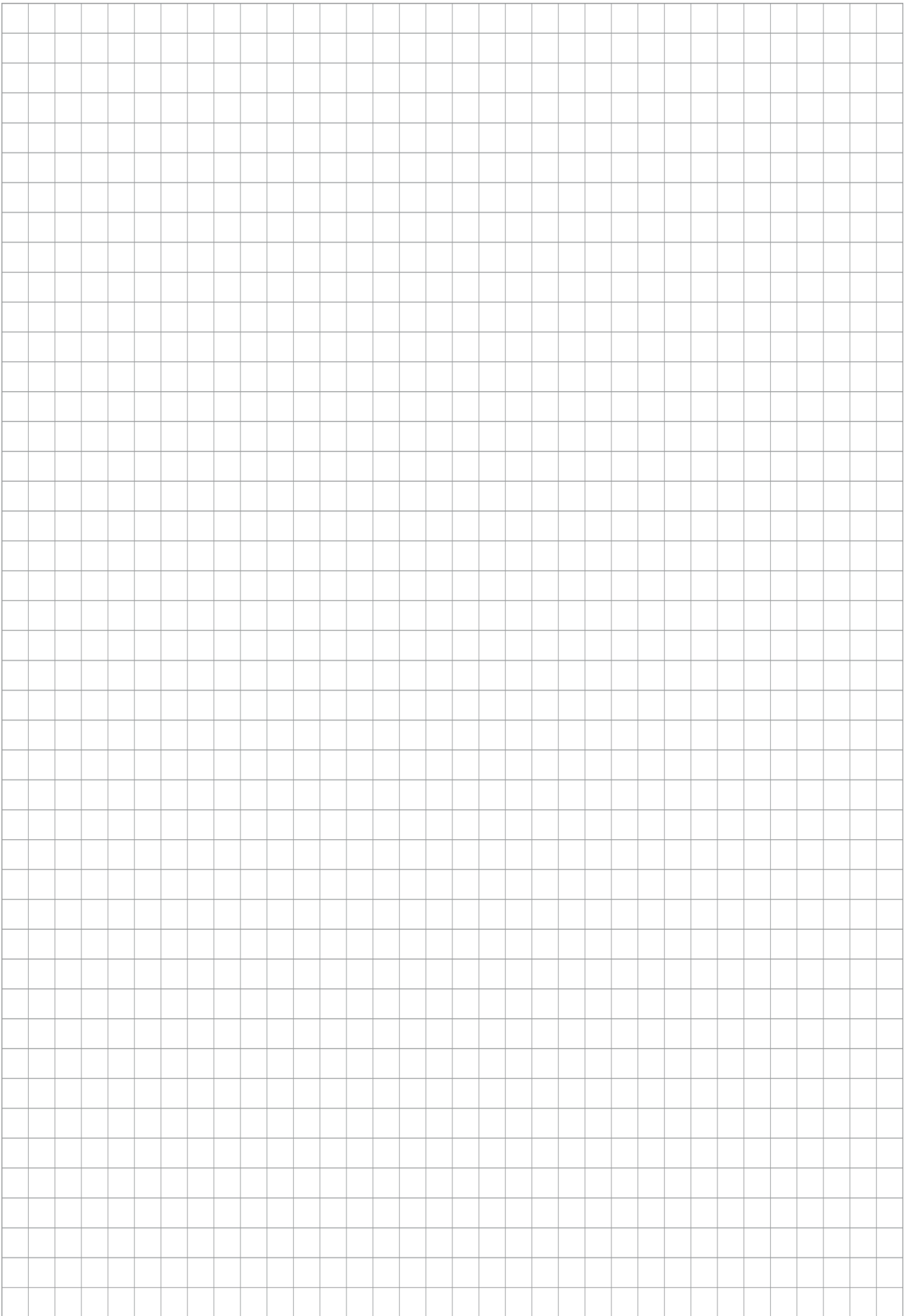

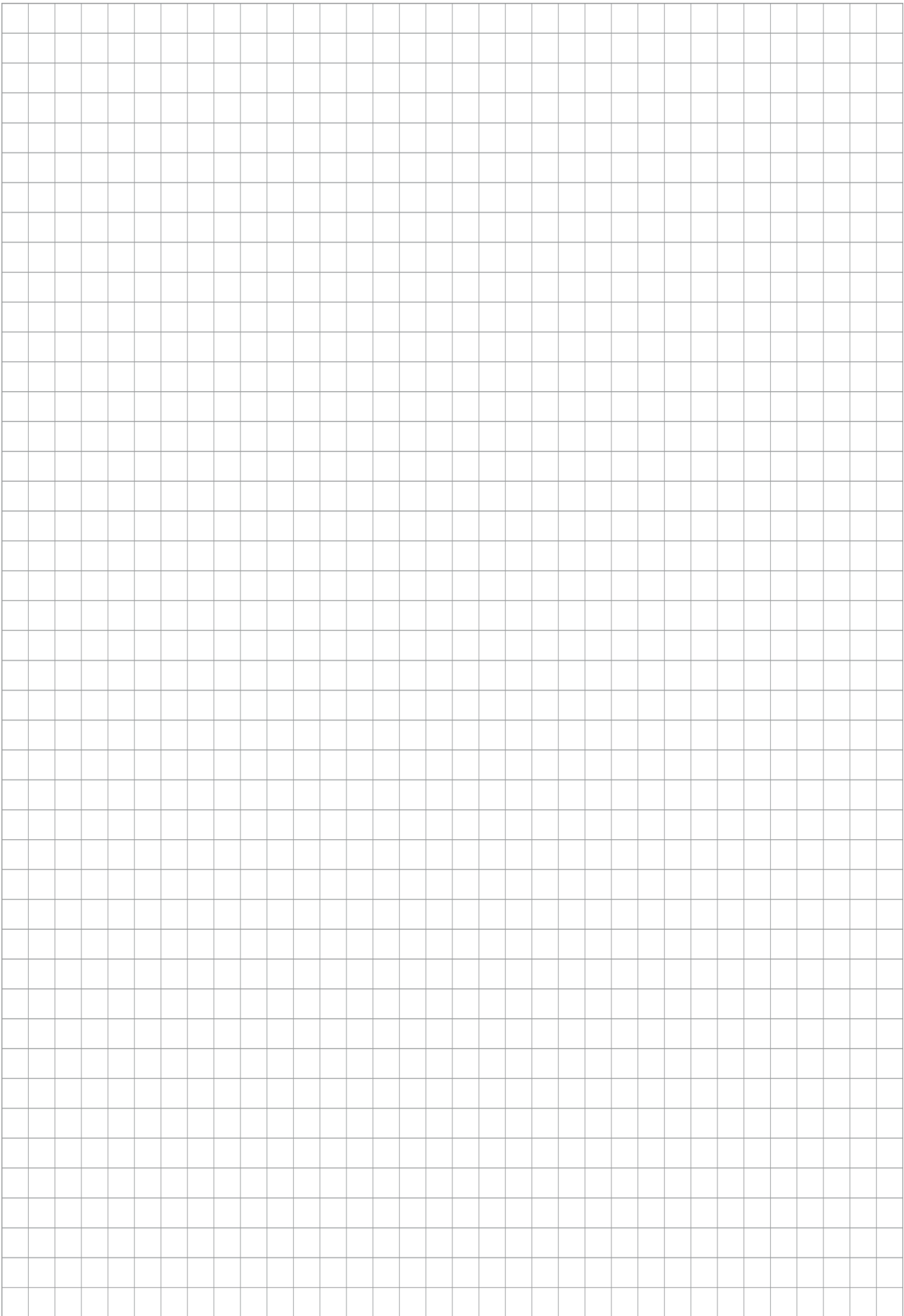



SCHUNK SE & Co. KG
Spanntechnik | Greiftechnik | Automatisierungstechnik

Bahnhofstr. 106 - 134
D-74348 Lauffen/Neckar
Tel. +49-7133-103-0
info@de.schunk.com
schunk.com

Folgen Sie uns | *Follow us*



Wir drucken nachhaltig | *We print sustainable*