

Assembly and operation manual

SRU 20 - 60

Pneumatic Swivel Unit



Imprint

Copyright:

This manual is protected by copyright. The author is SCHUNK GmbH & Co. KG. All rights reserved. Any reproduction, processing, distribution (making available to third parties), translation or other usage - even excerpts - of the manual is especially prohibited and requires our written approval.

Technical changes:

We reserve the right to make alterations for the purpose of technical improvement.

Document number: 389430

Version: 13.00 | 16/04/2019 | en

© SCHUNK GmbH & Co. KG

All rights reserved.

Dear Customer,

thank you for trusting our products and our family-owned company, the leading technology supplier of robots and production machines.

Our team is always available to answer any questions on this product and other solutions. Ask us questions and challenge us. We will find a solution!

Best regards,

Your SCHUNK team

SCHUNK GmbH & Co. KG
Spann- und Greiftechnik

Bahnhofstr. 106 – 134
D-74348 Lauffen/Neckar

Tel. +49-7133-103-0

Fax +49-7133-103-2399

info@de.schunk.com

schunk.com

Table of contents

1	General	5
1.1	About this manual	5
1.1.1	Presentation of Warning Labels	5
1.1.2	Applicable documents	5
1.2	Warranty	6
1.3	Scope of delivery	6
1.3.1	Accessories pack.....	6
1.4	Accessories	7
1.4.1	Seal kit	7
2	Basic safety notes	8
2.1	Intended use.....	8
2.2	Not intended use.....	8
2.3	Constructional changes	8
2.4	Spare parts	8
2.5	Ambient conditions and operating conditions	9
2.6	Personnel qualification.....	9
2.7	Personal protective equipment.....	10
2.8	Notes on safe operation	10
2.9	Transport	10
2.10	Malfunctions.....	11
2.11	Disposal	11
2.12	Fundamental dangers.....	11
2.12.1	Protection during handling and assembly	11
2.12.2	Protection during commissioning and operation	12
2.12.3	Protection against dangerous movements.....	12
2.12.4	Protection against electric shock.....	12
2.13	Notes on particular risks.....	13
3	Technical data	15
4	Assembly and Commissioning	16
4.1	Mechanical connection	16
4.2	Pneumatic connection.....	18
4.3	Adjusting the end positions.....	21
4.4	Shock absorber travel - fine adjustment SRU 50 und SRU 60.....	22
4.5	Adjusting the center position (variant M)	23
4.6	Adjusting the center position (variant VM)	24
4.7	Mounting and adjusting the sensors	26
4.7.1	Magnetic switch MMS 22	26
4.7.2	Inductive proximity switches with male thread M8	27

5	Function and handling	29
5.1	Base unit	29
5.2	Center position (variant M)	30
5.3	Locked center position (variant VM)	31
5.3.1	Mounting the separating sleeve	34
6	Troubleshooting	35
6.1	Product does not move smoothly to the end positions	35
6.2	Product does not travel through the rotating angle	35
6.3	Product rotates jerkily	35
6.4	Product does not move	36
6.5	Torque drops?	36
7	Maintenance	37
7.1	Maintenance intervals	37
7.2	Lubricants/Lubrication points (basic lubrication)	37
7.3	Dismantling the module	38
7.3.1	Dismantling the rotary actuator	38
7.3.2	Disassemble and assemble center position (variants M and VM)	38
7.4	Replacing a shock absorber	38
7.4.1	How to use the shock absorbers and installation dimensions	41
7.4.2	Measuring instruction	42
7.5	Servicing the product	42
7.6	Assembly drawings	43
8	Translation of original declaration of incorporation	46
9	Annex to Declaration of Incorporation	47

1 General

1.1 About this manual

This manual contains important information for a safe and appropriate use of the product.

This manual is an integral part of the product and must be kept accessible for the personnel at all times.

Before starting work, the personnel must have read and understood this operating manual. Prerequisite for safe working is the observance of all safety instructions in this manual.

Illustrations in this manual are provided for basic understanding and may differ from the actual product design.

In addition to these instructions, the documents listed under [Applicable documents](#) [► 5] are applicable.

1.1.1 Presentation of Warning Labels

To make risks clear, the following signal words and symbols are used for safety notes.



⚠ DANGER

Danger for persons!

Non-observance will inevitably cause irreversible injury or death.



⚠ WARNING

Dangers for persons!

Non-observance can lead to irreversible injury and even death.



⚠ CAUTION

Dangers for persons!

Non-observance can cause minor injuries.

NOTICE

Material damage!

Information about avoiding material damage.

1.1.2 Applicable documents

- General terms of business*
- Catalog data sheet of the purchased product *

The documents marked with an asterisk (*) can be downloaded on our homepage schunk.com

1.2 Warranty

If the product is used as intended, the warranty is valid for 24 months from the ex-works delivery date under the following conditions:

- Observe the specified maintenance and lubrication intervals
- Observe the ambient conditions and operating conditions

Parts touching the workpiece and wear parts are not included in the warranty.

1.3 Scope of delivery

The scope of delivery includes

- Pneumatic Swivel Unit SRU in the version ordered
- Assembly and Operating Manual
- Accessory pack

1.3.1 Accessories pack

Id-No. Accessory pack SRU

20	25	30	35	40	50	60
Without fluid feed-through						
5514981		5518653	5514989	5514993	5514997	5515001
With fluid feed-through						
5514982		5518654	5514990	5514994	5514998	5515002
With center position						
5516590		5518657	5516594	5516596	5516598	5516600
With locked center position						
5514983		5518655	5514991	5514995	5514999	5515003
With fluid feed-through and center position						
5516591		5518658	5516595	5516597	5516599	5516601
With fluid feed-through and locked center position						
5514984		5518656	5514992	5514996	5515000	5515004

Content of the accessories pack: [Assembly drawings](#) [▶ 43].

1.4 Accessories

A wide range of accessories are available for this product
For information regarding which accessory articles can be used
with the corresponding product variants, see catalog data sheet.

1.4.1 Seal kit

ID.-No. of the seal kitSRU

Seal kit for						
SRU 20	SRU 25	SRU 30	SRU 35	SRU 40	SRU 50	SRU 60
Basic seal kit						
0371000	0371004	5518598	0371008	0371012	0371016	0371020
with center position						
0371001	0371005	5518600	0371009	0371013	0371017	0371021
with locked center position						
0371002	0371006	5518601	0371010	0371014	0371018	0371022
with media feed-through						
0371003	0371007	5518599	0371011	0371015	0371019	0371023
with center position and media feed-through						
5517804	5517805	5517806	5517807	5517808	5517809	5517810
with locked center position and media feed-through						
5517811	5517812	5517813	5517814	5517815	5517816	5517817

Contents of the sealing kit, [Assembly drawings](#) [▶ 43].

2 Basic safety notes

2.1 Intended use

The product may only be used for swiveling permissible attachment parts or workpieces.

- The product may only be used within the scope of its technical data, [Technical data](#) [► 15].
- When implementing and operating components in safety-related parts of the control systems, the basic safety principles in accordance with DIN EN ISO 13849-2 apply. The proven safety principles in accordance with DIN EN ISO 13849-2 also apply to categories 1, 2, 3 and 4.
- The product is intended for installation in a machine/system. The applicable guidelines must be observed and complied with.
- The product is intended for industrial and industry-oriented use.
- Appropriate use of the product includes compliance with all instructions in this manual.

2.2 Not intended use

- Any utilization that exceeds or differs from the appropriate use is regarded as misuse.

Inappropriate use includes using the product as a lifting tool, tool guide or drive tool, for example.

2.3 Constructional changes

Implementation of structural changes

By conversions, changes, and reworking, e.g. additional threads, holes, or safety devices can impair the functioning or safety of the product or damage it.

- Structural changes should only be made with the written approval of SCHUNK.

2.4 Spare parts

Use of unauthorized spare parts

Using unauthorized spare parts can endanger personnel and damage the product or cause it to malfunction.

- Use only original spare parts or spares authorized by SCHUNK.

2.5 Ambient conditions and operating conditions

Required ambient conditions and operating conditions

Incorrect ambient and operating conditions can make the product unsafe, leading to the risk of serious injuries, considerable material damage and/or a significant reduction to the product's life span.

- Make sure that the product is used only in the context of its defined application parameters, [Technical data](#) [▶ 15].
- Make sure that the product is a sufficient size for the application.
- Make sure that the environment is free from splash water and vapors as well as from abrasion or processing dust. Exceptions are products that are designed especially for contaminated environments.

2.6 Personnel qualification

Inadequate qualifications of the personnel

If the personnel working with the product is not sufficiently qualified, the result may be serious injuries and significant property damage.

- All work may only be performed by qualified personnel.
- Before working with the product, the personnel must have read and understood the complete assembly and operating manual.
- Observe the national safety regulations and rules and general safety instructions.

The following personal qualifications are necessary for the various activities related to the product:

Trained electrician	Due to their technical training, knowledge and experience, trained electricians are able to work on electrical systems, recognize and avoid possible dangers and know the relevant standards and regulations.
Qualified personnel	Due to its technical training, knowledge and experience, qualified personnel is able to perform the delegated tasks, recognize and avoid possible dangers and knows the relevant standards and regulations.
Instructed person	Instructed persons were instructed by the operator about the delegated tasks and possible dangers due to improper behaviour.
Service personnel of the manufacturer	Due to its technical training, knowledge and experience, service personnel of the manufacturer is able to perform the delegated tasks and to recognize and avoid possible dangers.

2.7 Personal protective equipment

Use of personal protective equipment

Personal protective equipment serves to protect staff against danger which may interfere with their health or safety at work.

- When working on and with the product, observe the occupational health and safety regulations and wear the required personal protective equipment.
- Observe the valid safety and accident prevention regulations.
- Wear protective gloves to guard against sharp edges and corners or rough surfaces.
- Wear heat-resistant protective gloves when handling hot surfaces.
- Wear protective gloves and safety goggles when handling hazardous substances.
- Wear close-fitting protective clothing and also wear long hair in a hairnet when dealing with moving components.

2.8 Notes on safe operation

Incorrect handling of the personnel

Incorrect handling and assembly may impair the product's safety and cause serious injuries and considerable material damage.

- Avoid any manner of working that may interfere with the function and operational safety of the product.
- Use the product as intended.
- Observe the safety notes and assembly instructions.
- Do not expose the product to any corrosive media. This does not apply to products that are designed for special environments.
- Eliminate any malfunction immediately.
- Observe the care and maintenance instructions.
- Observe the current safety, accident prevention and environmental protection regulations regarding the product's application field.

2.9 Transport

Handling during transport

Incorrect handling during transport may impair the product's safety and cause serious injuries and considerable material damage.

- When handling heavy weights, use lifting equipment to lift the product and transport it by appropriate means.
- Secure the product against falling during transportation and handling.
- Stand clear of suspended loads.

2.10 Malfunctions

Behavior in case of malfunctions

- Immediately remove the product from operation and report the malfunction to the responsible departments/persons.
- Order appropriately trained personnel to rectify the malfunction.
- Do not recommission the product until the malfunction has been rectified.
- Test the product after a malfunction to establish whether it still functions properly and no increased risks have arisen.

2.11 Disposal

Handling of disposal

The incorrect handling of disposal may impair the product's safety and cause serious injuries as well as considerable material and environmental harm.

- Follow local regulations on dispatching product components for recycling or proper disposal.

2.12 Fundamental dangers

General

- Observe safety distances.
- Never deactivate safety devices.
- Before commissioning the product, take appropriate protective measures to secure the danger zone.
- Disconnect power sources before installation, modification, maintenance, or calibration. Ensure that no residual energy remains in the system.
- If the energy supply is connected, do not move any parts by hand.
- Do not reach into the open mechanism or movement area of the product during operation.

2.12.1 Protection during handling and assembly

Incorrect handling and assembly

Incorrect handling and assembly can make the product unsafe and pose a risk of serious injuries and considerable material damage.

- Order all work to be performed only by appropriately qualified personnel.
- For all work, secure the product against accidental operation.
- Observe the relevant accident prevention regulations.

2.12.2 Protection during commissioning and operation

Falling or violently ejected components

Falling and violently ejected components can cause serious injuries and even death.

- Take appropriate protective measures to secure the danger zone.
- Never step into the danger zone during operation.

2.12.3 Protection against dangerous movements

Unexpected movements

Residual energy in the system may cause serious injuries while working with the product.

- Switch off the energy supply, ensure that no residual energy remains and secure against inadvertent reactivation.
- Never rely solely on the response of the monitoring function to avert danger. Until the installed monitors become effective, it must be assumed that the drive movement is faulty, with its action being dependent on the control unit and the current operating condition of the drive. Perform maintenance work, modifications, and attachments outside the danger zone defined by the movement range.
- To avoid accidents and/or material damage, human access to the movement range of the machine must be restricted. Limit/prevent accidental access for people in this area due through technical safety measures. The protective cover and protective fence must be rigid enough to withstand the maximum possible movement energy. EMERGENCY STOP switches must be easily and quickly accessible. Before starting up the machine or automated system, check that the EMERGENCY STOP system is working. Prevent operation of the machine if this protective equipment does not function correctly.

2.12.4 Protection against electric shock

Possible electrostatic energy

Components or assembly groups may become electrostatically charged. When the electrostatic charge is touched, the discharge may trigger a shock reaction leading to injuries.

- The operator must ensure that all components and assembly groups are included in the local potential equalisation in accordance with the applicable regulations.
- While paying attention to the actual conditions of the working environment, the potential equalisation must be implemented by a specialist electrician according to the applicable regulations.
- The effectiveness of the potential equalisation must be verified by executing regular safety measurements.

2.13 Notes on particular risks



⚠ DANGER

Risk of fatal injury from suspended loads!

Falling loads can cause serious injuries and even death.

- Stand clear of suspended loads and do not step within their swiveling range.
- Never move loads without supervision.
- Do not leave suspended loads unattended.
- Wear suitable protective equipment.



⚠ WARNING

Risk of injury from objects falling and being ejected!

Falling and ejected objects during operation can lead to serious injury or death.

- Take appropriate protective measures to secure the danger zone.



⚠ WARNING

Risk of injury due to unexpected movements!

If the power supply is switched on or residual energy remains in the system, components can move unexpectedly and cause serious injuries.

- Before starting any work on the product: Switch off the power supply and secure against restarting.
- Make sure, that no residual energy remains in the system.



⚠ WARNING

Risk of injury from sharp edges and corners!

Sharp edges and corners can cause cuts.

- Use suitable protective equipment.



⚠ WARNING

Risk of burns through contact with hot surfaces!

The product can heat up considerably during operation. Touching hot surfaces can cause burns.

- Do not touch hot surfaces.
- Let them cool down before working on the product.
- Wear appropriate safety equipment.



⚠ WARNING

Risk of injury from parts coming loose!

If the shock absorbers are faulty, the product can become damaged. Parts coming loose in this way can lead to injuries.

- Regularly check the components for wear and damage.
-



⚠ WARNING

Risk of injury if the condition or behavior of the product is undefined!

Cutting off the compressed air supply in an uncontrolled manner could lead to undefined states and behavior. This may cause personal injury or material damage.

- The operator must define suitable emergency stop and restarting strategies.
 - ✓ Emergency stop strategies: e.g. by means of controlled shut down
 - ✓ Restarting strategies: e.g. using pressure build-up valves or suitable valve switching sequences
-

3 Technical data

Basis data

Designation	Value
Noise emission [dB(A)]	≤70
Pressure medium	Compressed air, compressed air quality according to ISO 8573-1:7 4 4

More technical data is included in the catalog data sheet.
Whichever is the latest version.

4 Assembly and Commissioning

4.1 Mechanical connection



⚠ WARNING

Risk of injury when the machine/system moves unexpectedly!
Switch off power supply.

Assembly

The module can be mounted from the base.

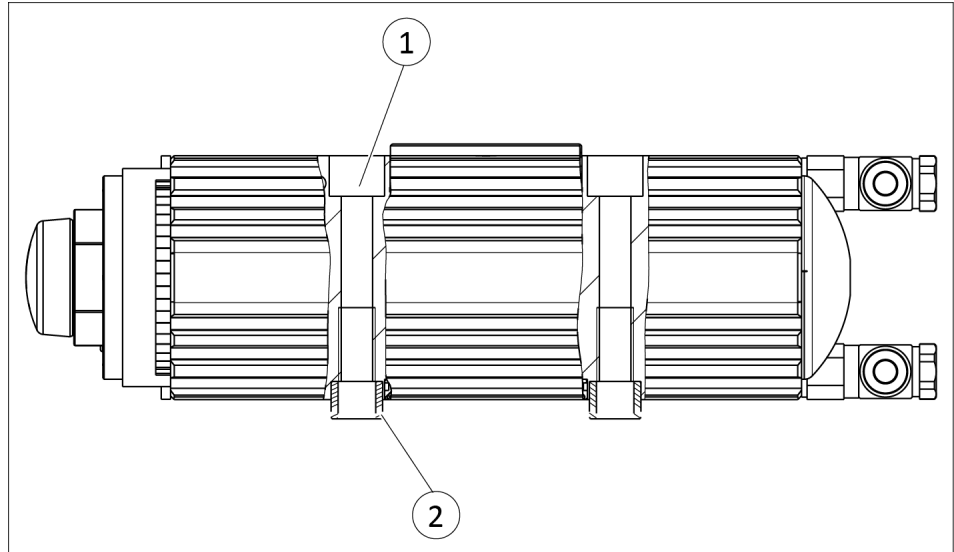

Mounting possibilities

mounting material (* provided by customer/ ** included in the enclosed pack)

Item	Designation	SRU						
		20	25	30	35	40	50	60
1*	Screw	M6	M6	M6	M8	M8	M10	M12
2**	Centering sleeve	Ø12	Ø12	Ø12	Ø12	Ø14	Ø16	Ø16

Fastening at the base

- Use the centering sleeves from the enclosed pack.
- Secure the module from the output side via the drill holes provided for this purpose, or at the base using the threads.

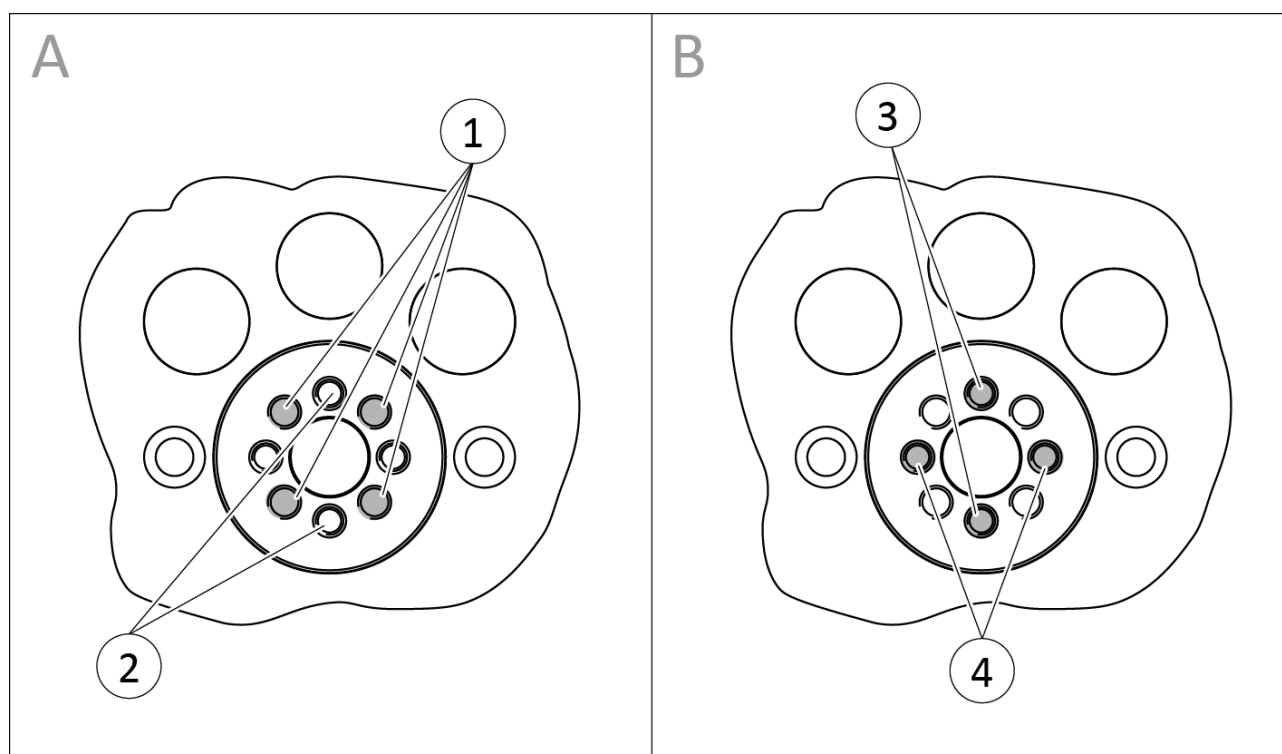

Mount attachment parts on the pinion

The following mounting materials must be provided by customer:

mounting material (* provided by customer/ ** included in the enclosed pack)

Item	Designation	SRU						
		20	25	30	35	40	50	60
1 *	Screw	M6	M6	M6	M16	M8	M10	M10
2 *	Screw	M5	M6	M6	M6	M8	M10	M10
3 *	Fitting screw	M5	M5	M5	M5	M6	M8	M8
4 **	Centering sleeve	Ø6,0	Ø6,0	Ø6,0	Ø6,0	Ø8,0	Ø10	Ø10

Pinion mounting

- Use the centering sleeves (1) from the enclosed pack.
- Fasten the attachment on the four threaded holes (2).
- For this, use the 2 counterbores for the centering sleeves (4).

Pinion mounting with optional inductive proximity switch

- The control cam retaining plate must be fixed with the centering sleeves (4) between the pinion and a customer side mounting plate.
- Attach the mounting plate via the 4 threaded holes (2).
- Secure attachment on the mounting plate.

4.2 Pneumatic connection



⚠ WARNING

Risk of injury when the machine/system moves unexpectedly!

Remove the energy supplies.

Make sure that no residual energy remains in the system.

NOTE

- Observe the requirements for the compressed air supply, [Technical data](#) [▶ 15].
 - In case of compressed air loss (cutting off the energy line), the components lose their dynamic effects and do not remain in a secure position. However, the use of a SDV-P pressure maintenance valve is recommended in this case in order to maintain the dynamic effect for some time. Product variants are also offered with mechanical gripping force via springs, which also ensure a minimum clamping force in the event of a pressure drop.
-
- Only open the air connections required.
 - Seal air connections not required using the locking screws from the enclosed pack.
 - For hose-free direct connections use the two O-rings from the enclosed pack.

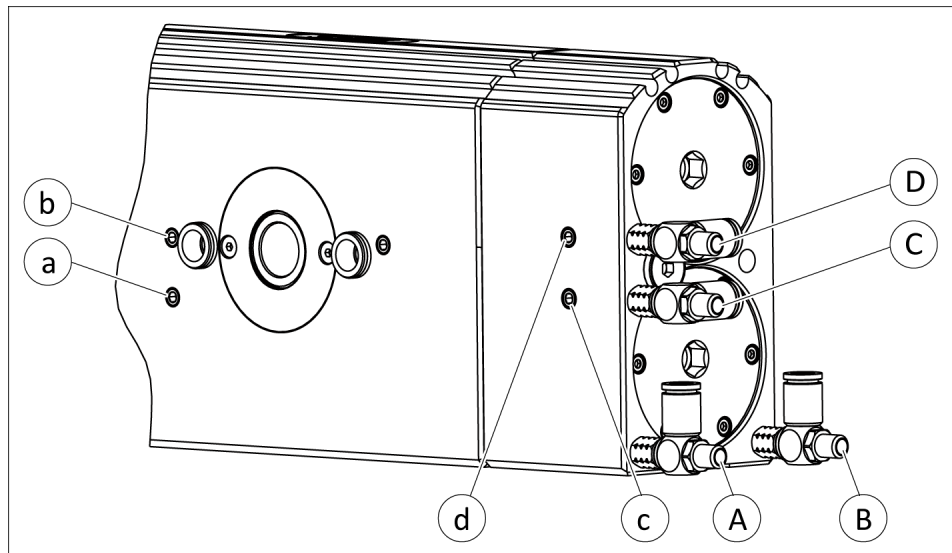

Air connections, variant with center position

Item	Designation	Description	Function
1	b	Hose-free direct connection	swiveling 90° - 0°/180° - 0°
2	a		swiveling 0° - 90°/0° - 180°
3	d		Approach center position (M)
4	c		Extend locking position (VM)
5	C	Hose connection	Approach center position (M)
6	D		Extend locking position (VM)
7	A		swiveling 0° - 90°/0° - 180°
8	B		swiveling 90° - 0°/180° - 0°

Pay attention to the following table when using throttles.

Air connection for variant with center position (M)

- The air connections labeled "C" and "D" must be pressurized together (with intersection).

NOTICE

In the variant with locked center position, this can cause malfunctions!

- Do not install an exhaust air throttle.
- Observe table [Use of throttles](#) [► 20].

Air connection for variant with locked center position (VM)

NOTE

The operating pressure of the lock must be between 4 and 6 bar.

- In addition, air connections that are marked "C" and "D" are available [Air connections, variant with center position](#) [▶ 19].
- The lock can be retracted smoothly using a supply air throttle. Tab. [Use of throttles](#) [▶ 20]

Variant with media feed-through

- Connections marked with numbers are provided for feed-through of the media on the pinion and the flange.

Use of throttles

Module variant	A		B		C	D
without center position	Exhaust air throttle/or no throttle		Exhaust air throttle/or no throttle		-	-
with center position (M)	Exhaust air throttle/or no throttle		Exhaust air throttle/or no throttle		Supply air throttle/or no throttle	Supply air throttle /or no throttle
with locked center position (VM)	Supply air throttle/or no throttle		Supply air throttle/or no throttle		Supply air throttle/or no throttle/or quick air relief valve	Supply air throttle/or no throttle/or quick air relief valve
with locked center position (VM) and separate main piston chambers	A1 Exhaust air throttle/or no throttle	A2 no throttle!	B1 Exhaust air throttle/or no throttle	B2 no throttle!	Supply air throttle/or no throttle	Supply air throttle/or no throttle

4.3 Adjusting the end positions

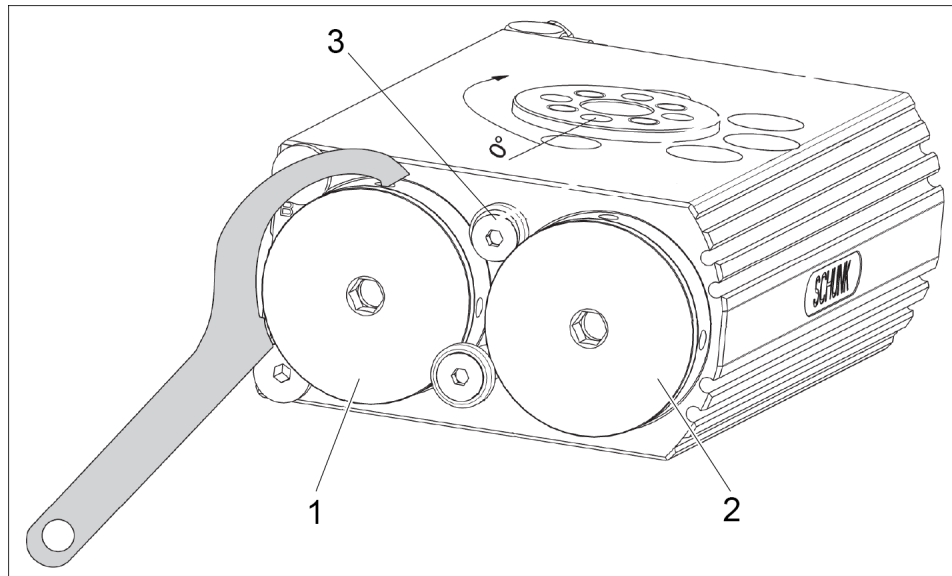

Basic setting

NOTICE

The end positions should not be changed by turning the axial hexagon socket at the face, or by turning the clamping nut or the shock absorber (VM-versions).



This way the individual components can be unscrewed.

- Please use a hook wrench, which is positioned in the radial bore of the adjustment sleeve

NOTICE

The end positions should not be changed by turning the axial hexagon socket at the face, or by turning the clamping nut or the shock absorber (VM-versions).

This way the individual components can be unscrewed.

- Please use a  19 (SRU 20 – 25) or 32 (SRU 30 – 60), which is positioned at the hexagon of the stop cover
- Loosen bolt (3) approx. one turn using hexagon socket wrench (SRU 20 – 40:  4, SRU 50 – 60:  5).
 - Apply air to connection "B". Unit swivels to stop A (1) (basic setting 0°).
 - Set the desired end position by turning stop A. (For SRU 50-60; depressurize before adjusting)
 - Vent connection B and apply air to A. The unit swivels to stop B (3)(basic setting 180°).
 - Set the required limit position by rotating stop B (3). (For SRU 50-60: depressurize before adjusting)

- Tighten Screws (2) fully.
(SRU 20-40: 10Nm; SRU 50-60: 24Nm)
- Swivel repeatedly to test the limit position setting.

NOTICE

The limiting sleeves (depending on the variant item 7, 10, 25) limit the adjustment range of the stops. For safety reasons, the unit should only be operated with mounted limiting sleeves.

4.4 Shock absorber travel - fine adjustment SRU 50 und SRU 60

NOTICE

The module can leak if the maximum adjustment range is exceeded:

- Note the maximum adjustment range of **3 mm** of the fine adjustment.

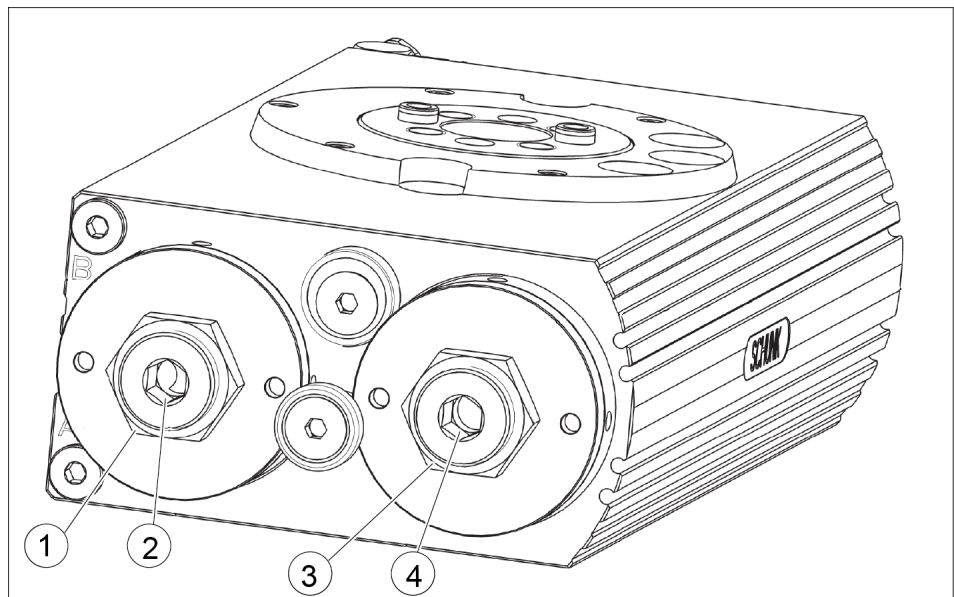

Shock absorber fine adjustment

1	Stop A	2	Stop B
---	--------	---	--------

Setting the dampening for end position 0°/180°

NOTICE

The maximum range for fine adjustment is 3 mm. After that, leakage begins in order to protect the unit.

- (a) To adjust the damping in the end position 0°, loosen the nut (1) at the limit A using a spanner 30mm while counterholding the striker pin (2) with a hexagon socket key 10mm.
- (b) To adjust the damping in the end position 180°, loosen the nut (item 101 b) at the limit B using a spanner 30mm while counterholding the striker pin (4) with a hexagon socket key 10mm.
- Turning out the striker pin shortens the damping travel by 1.5 mm per revolution (max. 3 mm).
- Swivel the loaded unit to check the damping effect.
 - ✓ The end positions must be arrived at gently.
- Retighten the nuts (1 and 2).

4.5 Adjusting the center position (variant M)

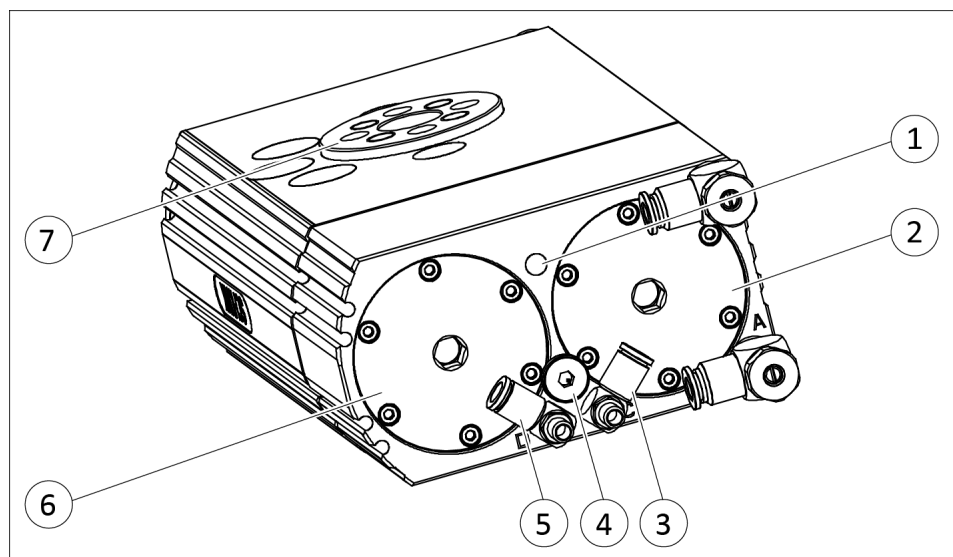

Adjusting the center position

1	Stop B	3	Interior screw	5	Limiting sleeve
2	Stop A	4	Stop C	6	Stop D

- Loosen the screw (3) with hexagon socket wrench (SRU 20-40: 4, SRU 50-60: 5) by approx. one turn.
- Unscrew stops C (4) and D (6) as far as the limiting sleeve (5)
- Apply air to the air connections marked C and D together
 - ✓ The unit swivels to approx. 90° and has approx. 6° play in this position
- Rotate the pinion clockwise and press it against stop C (4)
- Turn stop C (4) until the desired centre position is reached
- Turn stop D (6) until the pinion has no more play in centre position

- Tighten the screw (3) securely again (SRU 20-40: 10Nm, SRU 50 – 60: 24 Nm)
- Swivel the unit several times to check that the centre position is correctly set

4.6 Adjusting the center position (variant VM)

NOTICE

The lock could be damaged!

- Pay attention to the description of Locked center position (variant VM).

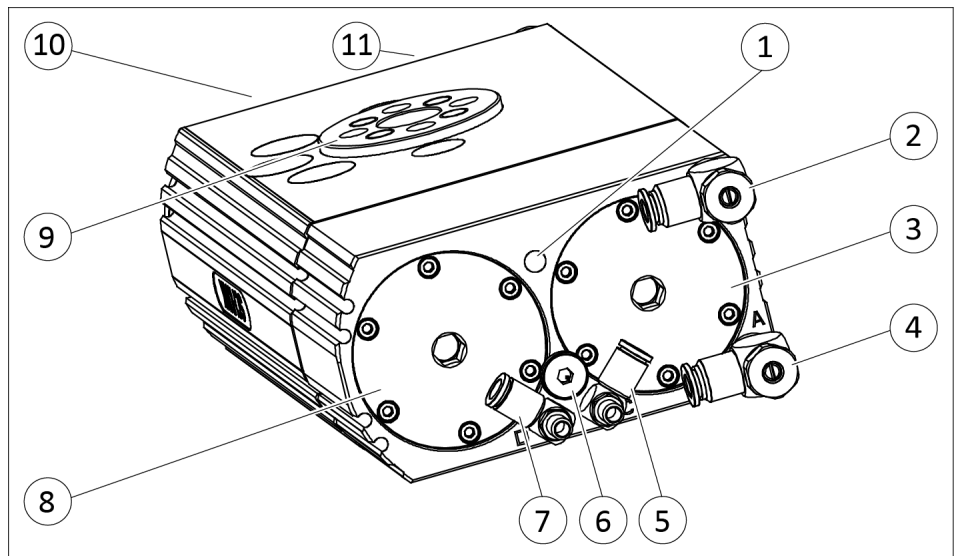

Adjusting of the center position locking

1	Stop B	5	Stop C
2	Stop A	6	Limiting sleeve
3	Bore hole for hexagon socket wrench		
4	Internal screw	7	Stop D

Depending on the start-up direction of (stop A (2) or stop B (1)), the center position can be set the same or differently.

- Ventilate all air connections.
- Loosen the screw (4) about one turn with hexagon socket wrench (SRU-plus 20-40:
◆ 4, SRU 50-60: ◆ 5)
- Actuate air connection "B".
 - ✓ The module swivels to stop A (2).
- Ventilate air connection "B" and pressurize air connection "C".
 - ✓ Stop C (5) locks.
- Actuate air connection "A".
 - ✓ The module swivels to stop C (5) (basic setting 90°).
- Turn stop C (5) to the required center position.
- Ventilate air connection "C".
 - ✓ The module swivels to stop B (1).
- Ventilate air connection "A" and actuate air connection "D".
 - ✓ Stop D (7) locks.
- Actuate air connection "B".
 - ✓ The module swivels to stop D (7) (basic setting 90°).
- Turn stop D (7) to the required center position.
- Re-tighten the screw (4) again (SRU 20-40: 10Nm, SRU 50-60: 24Nm).
- Swivel repeatedly to test the center position setting [Electrical circuit diagram actuation with two 5/3 directional control valves \(example\)](#) [▶ 32].

4.7 Mounting and adjusting the sensors

The module is prepared for the use of the sensors IN 80 and MMS 22.

- If you require further information on sensor operation, contact your SCHUNK contact person or download information from our homepage.
- Technical data of the sensors are contained in the data sheets (included in the scope of delivery).

4.7.1 Magnetic switch MMS 22

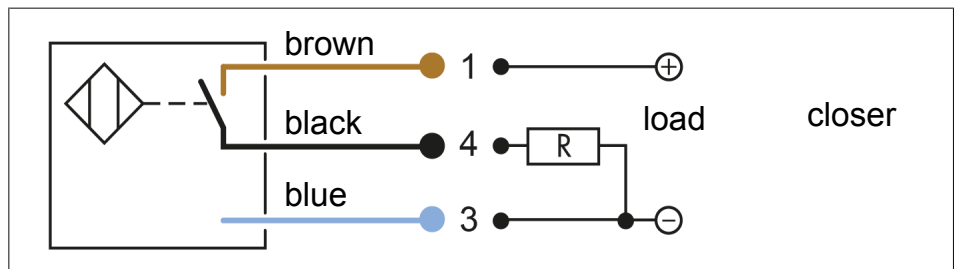
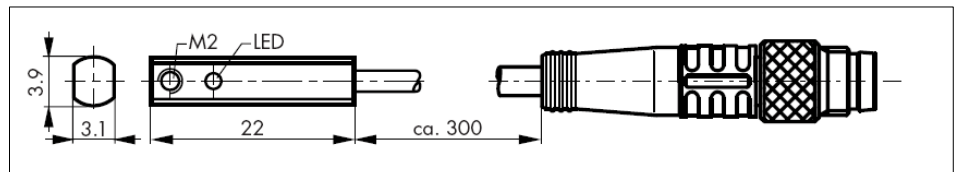

NOTICE

Material damage due to an incorrect tightening torque!

If the threaded pin is tightened with an incorrect tightening torque, the product may be damaged.

- Observe a maximum tightening torque of 10 Ncm for the set-screws.

NOTE

Ferromagnetic material changes the switching positions of the sensor. For example: Adapter plate made of ordinary steel.

At ferromagnetic adapter plates:

- First mount the product on the adapter plate.
- Then set the position of the magnetic switch.

Mounting of the magnetic switch

The magnetic switches can be mounted via four grooves in the module housing.

The setting of the switching positions must be done as follows:

- Turn the unit to the required swivel angle.
- Push the magnetic switch into the groove.
- Move the magnetic switch along the groove until it actuates.
- Secure the magnetic switch. (see enclosed data sheet)
- Check the switch position of the magnetic switch by swiveling the module repeatedly.

NOTE

We recommend the use of four magnetic switches to monitor the locked center position:

- One sensor each to monitor the two limit positions
- For monitoring approach to the center position from end position 0°
- For monitoring approach to the center position from end position 180°

4.7.2 Inductive proximity switches with male thread M8

NOTICE

Take care to ensure that the sensors do not collide with the control cams during swivel movements.

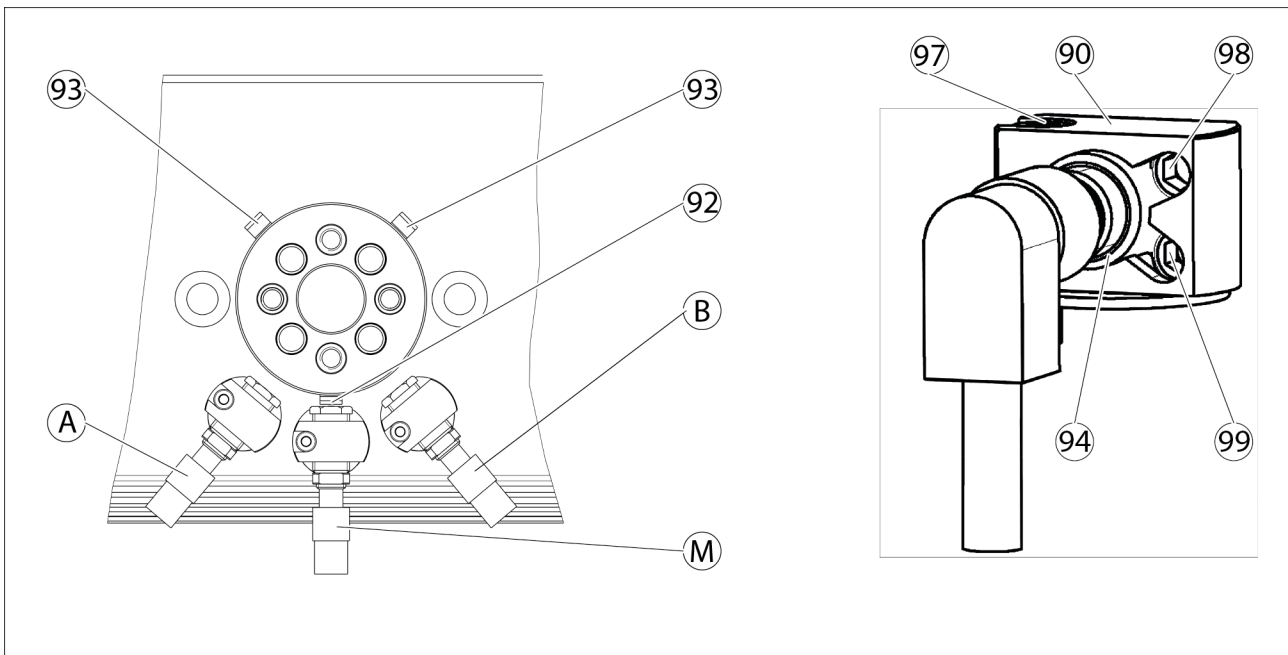

- Remove the round cover plates from the housing and fit the brackets (90) with the supplied hexagon socket screws (97). Ensure that the cylindrical collar of the holder is seated in the recess in the housing.
- Now screw the proximity switches (not included in mounting kit) into the brackets as far as they will go. Secure them in this position with the locking nut (94).
- Fit the control cams (92 and 93) to the control cam retaining plate (item 96) and mount these on the pinion using the centring sleeves.
- Turn the pinion anti-clockwise as far as stop A. Using a hexagon socket wrench, loosen the long control cam (93) and move it until it touches the proximity switch at stop A. Turn the pinion back again and fix the control cam in place. To set the sensing distance, turn the pinion to stop A once again (if necessary, facilitate this by applying air to connection B).
- With a hexagon socket wrench, loosen the locating bolt (98). Turn the setting screw until the proximity switch responds. Rotation clockwise (–) increases the distance, rotation anti-clockwise (+) reduces it. If larger adjustments are required, the locating bolt will have to be slackened off again.
- Once you have set the sensing distance, tighten the locating bolt fully by turning clockwise
- Proceed as above for setting the centre position and stop B. Take care to ensure that the sensors do not collide with the control cams during swivel movements.

5 Function and handling

5.1 Base unit

Move to basic setting 180° (end position B)

- Actuate air connection "A", pinion begins to move.
- ✓ Assembly swivels in clockwise direction until it reaches the end position "B".

Move to basic setting 0° (end position A)

- Actuate air connection "B", pinion begins to move.
- ✓ Assembly swivels until it reaches the end position "A".

Setting ranges of the variants

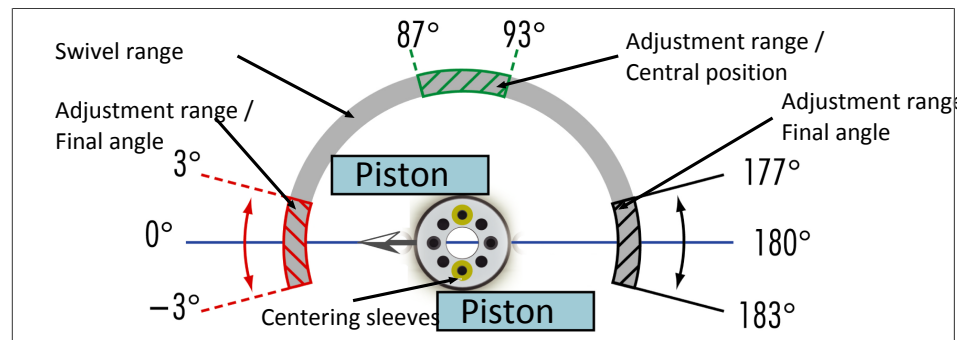

End position adjustability 3°

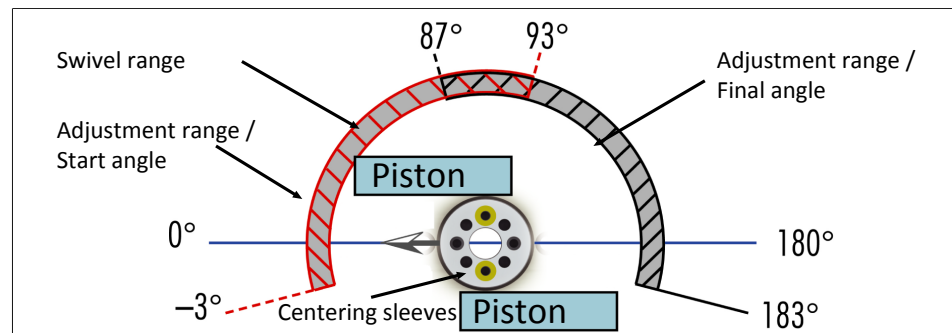

End position adjustability 90°

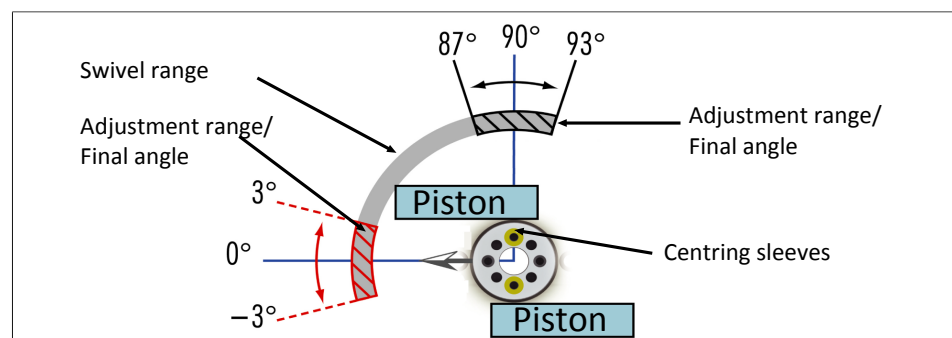

Angle of rotation 90° variant

5.2 Center position (variant M)

Basic setting 90°

➤ Actuate air connections "C" and "D".

✓ The pinion rotates to the centre position.

The centre position can be adjusted by $\pm 3^\circ$. Due to the way in which the unit works, overshoot may occur in the centre position.

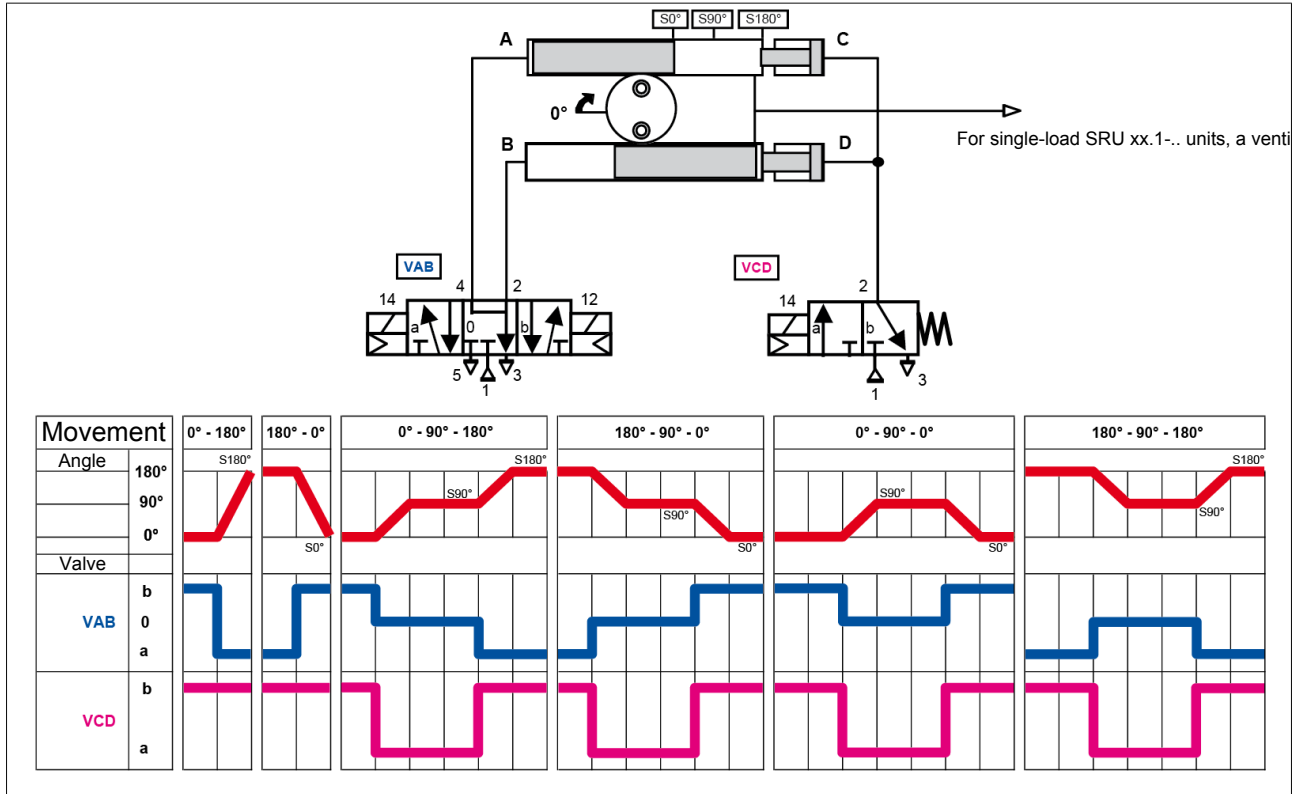

Actuation with a 5/3-way and a 3/2-way valve

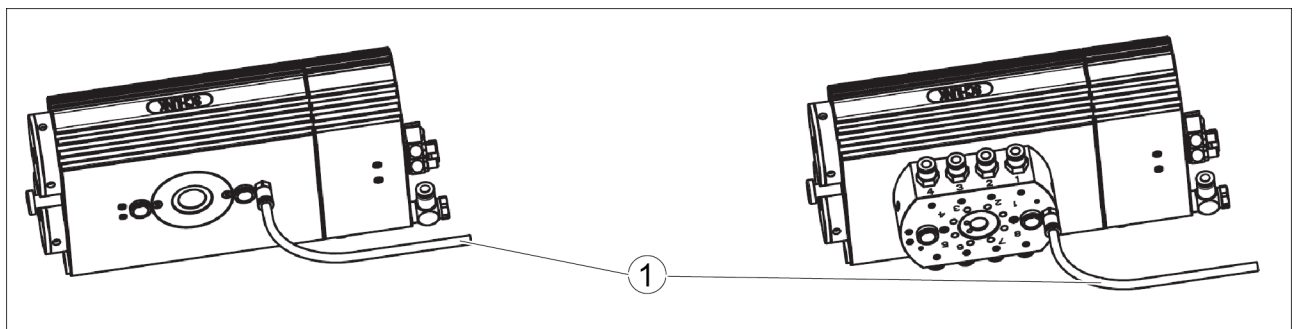

1	Exhaust line
---	--------------

5.3 Locked center position (variant VM)



⚠ WARNING

Risk of injury if the machine/system moves unexpectedly!

In an EMERGENCY STOP situation, the center position lock can come loose

- Swivel the module to one of the limit positions to restart.

NOTICE

The pistons can be damaged if incorrectly controlled.

- The locking pistons must be free to extend without striking the drive pistons.
- Note the circuit diagram [Electrical circuit diagram actuation with two 5/3 directional control valves \(example\)](#) [▶ 32].

If this option is selected, the locking pistons can stop the rotating motion in the center position and enable it again. The center position can be adjusted by $\pm 3^\circ$.

Move from the 0° position to the center position

- Extend locking piston C.
- Actuate connection A.

Move from the 180° position to the center position

- Extend locking piston D.
- Actuate air connection B.

NOTE

Before actuating C and D, connections A and B must be completely ventilated.

**Circuit diagram
control (example)**

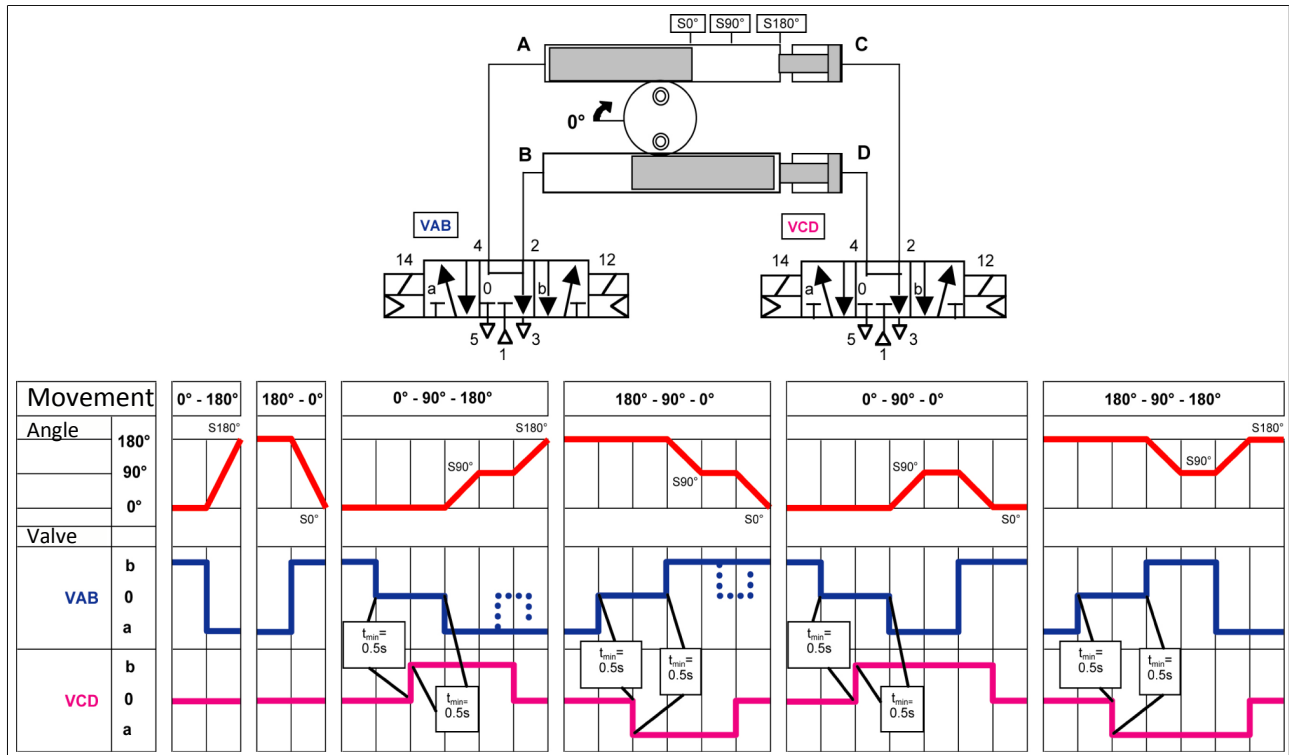

Electrical circuit diagram actuation with two 5/3 directional control valves (example)

If there is a danger that the unit might swivel unintentionally during the venting of the drive pistons (e.g. horizontal swivel axis with an asymmetrical load), the separator sleeves (item 96 in the enclosed pack) must be screwed into the air connections A1 and B1.

The two cylinder areas of connections A and B can then each be actuated separately. The following illustration shows holding the load at 0° by keeping B1 loaded until C is locked.

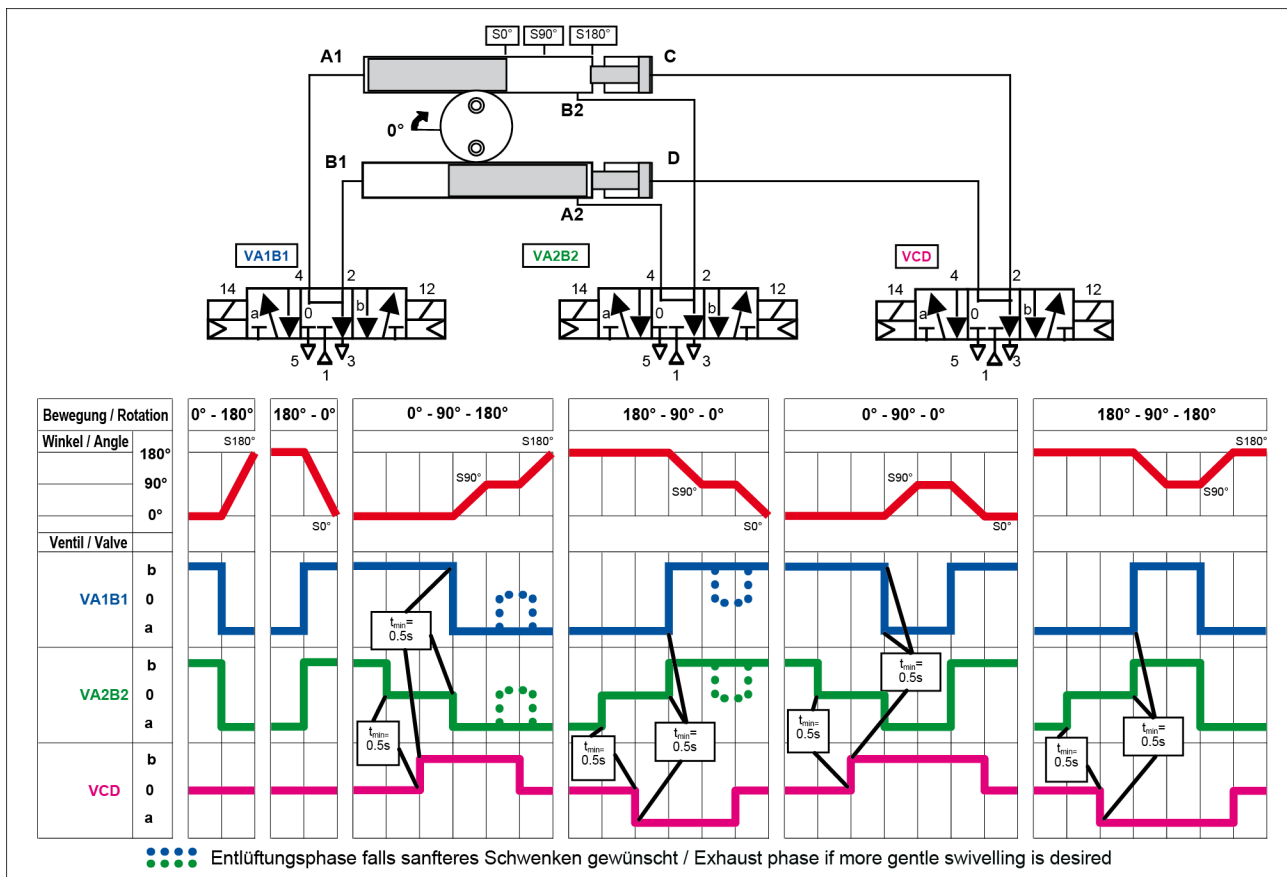

In order to reduce the drive torque during the swivel movement (e.g. unilateral load falling), it is possible to load just one piston area (1 or 2).

The following piston areas should be loaded at least in the end and / or centre position to avoid play in the output shaft:

- 0° B1
- 180° A1
- 90° A2 respectively B2

By installing the separator sleeve, it is also possible to insert exhaust flow controls in the connections A1 and B1. A2 and B2 then remain unrestricted.

5.3.1 Mounting the separating sleeve

NOTICE

The O-ring in the groove could be damaged!

- Screw the separating sleeve (2) very carefully until the end of the threads.

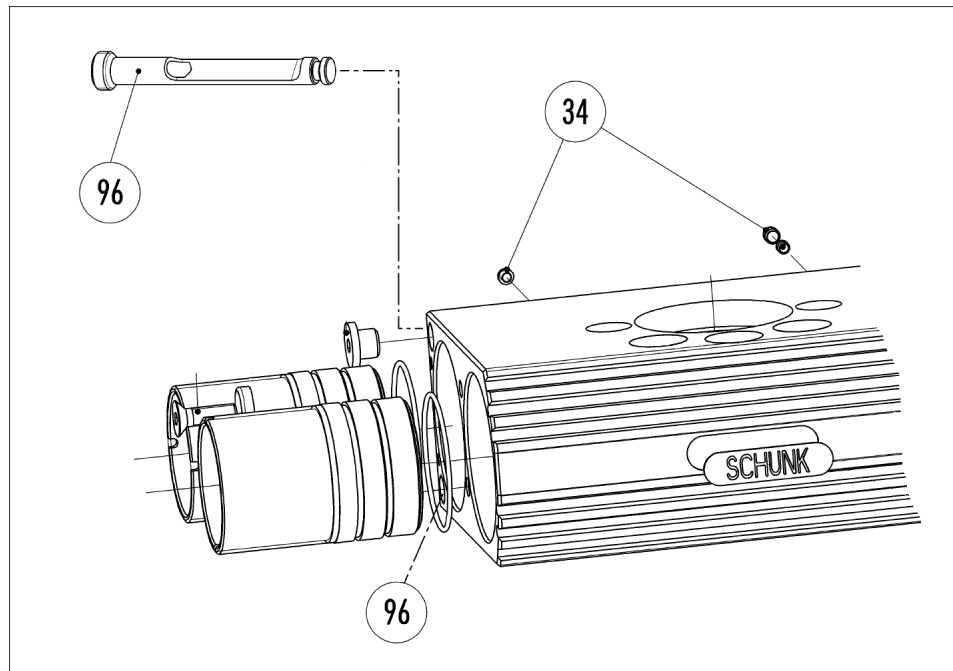

- Screw the separating sleeve 2x (2) from the accessory pack into hose connection holes A and B until the end of the threads.
- Screw back until the flattened side points towards the middle of the housing.
- Check the correct orientation:
 - ✓ With the orientation of the Allen key
 - ✓ After removing the set screw (34) via direct- air connections on the laterally mounting surface.
- Fit the hose connections A1, A2, B1 and B2.
Position of the hose connections
Position of the air connections

6 Troubleshooting

6.1 Product does not move smoothly to the end positions

Possible cause	Corrective action
Dampening stroke shifted.	Adjust absorber stroke.
Shock absorber defective.	Check or, if need be, replace the shock absorber. Maintenance [▶ 37]

6.2 Product does not travel through the rotating angle

Possible cause	Corrective action
Accumulation of dirt between stop / sleeve and pistons.	Clean and lubricate product. Maintenance [▶ 37]
End positions are adjusted incorrectly.	Adjust end position. Link Schwenkwinkel einstellen
Pressure drops below minimum.	Check air supply. Pneumatic connection [▶ 18]
Components have come loose e.g. due to overloading.	Send product with a SCHUNK repair order or dismantle product.
Shock absorber defective.	Check or, if need be, replace the shock absorber. Maintenance [▶ 37]

6.3 Product rotates jerkily

Possible cause	Corrective action
Too little grease in the mechanical guiding areas.	Clean and lubricate product. Maintenance [▶ 37]
Compressed air lines blocked.	Check compressed air lines of damage.
Swiveling speed set too fast	Adjust swiveling speed Link Geschwindigkeit einstellen

6.4 Product does not move

Possible cause	Corrective action
Component part defective.	Replace component or send it to SCHUNK for repair.
	Have Schunk check the application.
Pressure drops below minimum.	Check air supply. Pneumatic connection [▶ 18]
Compressed air lines switched.	Check compressed air lines.
Unused air connections open.	Close unused air connections. Pneumatic connection [▶ 18]
Both exhaust air throttle valves are closed.	Open one exhaust air throttle valve.
Proximity switch defective or set incorrect.	Adjust sensor or if necessary change sensor. Link Sensor montieren

6.5 Torque drops?

Possible cause	Corrective action
Compressed air can escape.	Test seals and, if need be, disassemble the module and replace the seals Maintenance [▶ 37]
Too much grease in the mechanical movement space.	Clean and lubricate product. Maintenance [▶ 37]
Pressure drops below minimum.	Check air supply. Pneumatic connection [▶ 18]

7 Maintenance

7.1 Maintenance intervals

NOTICE

Material damage due to hardening lubricants!

Lubricants harden more quickly at temperatures above 60°C, leading to possible product damage.

- Reduce the lubricant intervals accordingly.

Designation	SRU						
	20	25	30	35	40	50	60
Visual inspection of shock absorber function	Regular						
Recommended replacement of the shock absorber after [million cycles]	2					1	

To ensure the function, we recommend regular testing of the seals and the mechanism after around 4 million swivel movements, respectively 2 million cycles.

7.2 Lubricants/Lubrication points (basic lubrication)

SCHUNK recommends the lubricants listed.

During maintenance, treat all greased areas with lubricant. Thinly apply lubricant with a lint-free cloth.

Lubricant point	Lubricant
Metallic sliding surfaces	microGLEIT GP 360
All seals	Renolit HLT 2
Bore hole at the piston	Renolit HLT 2

7.3 Dismantling the module

7.3.1 Dismantling the rotary actuator

Position of the item numbers [Assembly drawings](#) [▶ 43]

- Remove all pressure and power lines
- Unscrew bolt (35), remove bolt and both stop covers
 - Without centre setting:**
 - Remove the curved cover (5)
 - With centre setting:**
 - Unscrew the bolt (35) on stops C and D by one revolution
 - Remove the fastening bolt (58) of the locating sleeve (25)
 - Unscrew stops C and D until the centre position housing (14) can be removed
- Mark the installation position of the pinion (2/ 19) and the piston (24)
- Disassemble the protective cover (22) and the snap ring on the pinion (49)
- **Media feed through option:**
 - Remove the flange (20)
- Push the pinion (2 / 19) out of the housing.

7.3.2 Disassemble and assemble center position (variants M and VM)



⚠ WARNING

Risk of injury due to spring forces!

In the interior of the centering housing (locked center position variant), a pre-loaded compression spring can be found.

- Carefully dismantle the product.

- Pull stops C and D out of the housing (14).
- Remove cover (18) of the adjusting sleeve (16).
- Remove stop piston (17).
- **Only locked center position:**
 - Remove the safety ring (51) on the stop piston (17).

7.4 Replacing a shock absorber

The shock absorbers have a limited life depending on the load. The shock absorbers are specially adjusted and can only be obtained from SCHUNK.

- Test the shock absorber for function regularly.
The shock absorber functions correctly when the module moves smoothly into the limit positions.

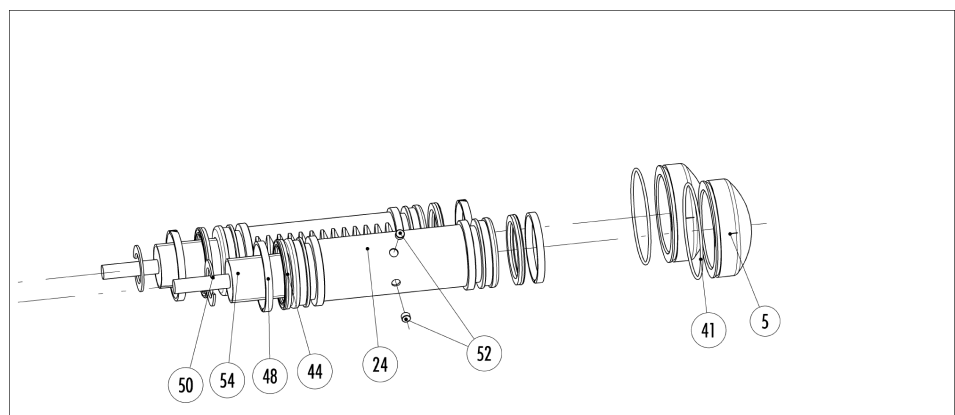
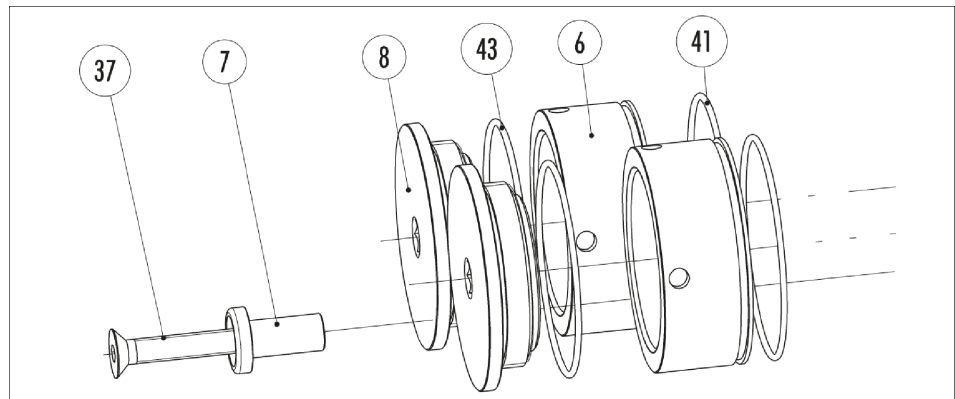
Base unit with internal shock absorber:

Position numbers not listed: [Assembly drawings](#) [► 43]

- Before turning, secure the adjusting sleeves (6) with a spanner wrench with pin (DIN 1810, form B). Should this key not be on hand, loose the clamping screw (35) about approx. 1 turn and remove the stop cover (8) and stop sleeve (6) together. After replacing the shock absorber the end position must be readjusted. [Adjusting the end positions](#) [► 21]
- Remove the safety rings (50) on the pistons.
- Pull out the shock absorber (54).
- Remove all fitting discs out of the drill hole.
- Insert a new shock absorber. **CAUTION:** Observe the shock absorber overhang, Shock absorber types and shock absorber overlap (h) and, if necessary, remove or add fitting discs.
- Add fitting discs to the safety rings until they can be mounted without play.
- Clean the threads of the stop cover (8)
- Reattach the stop cover (8), screw it into place and secure with Loctite Nr. 243.

with external absorbers

Option locked center position (VM variant)

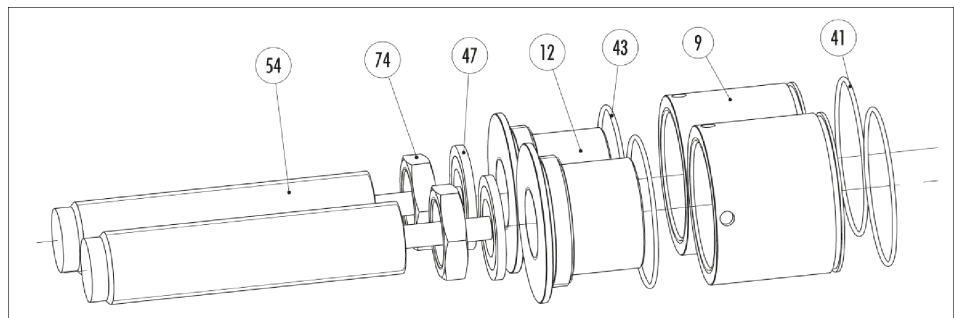

- Release the lock nuts (74) of the shock absorber
 - Unscrew the shock absorber from the thread.
 - Fully screw in the new shock absorber.
 - Fit the O-ring (47) on the shock absorber
 - Screw on the lock nuts (74) and tighten them.
 - Swivel repeatedly to test the setting.
- [Electrical circuit diagram actuation with two 5/3 directional control valves \(example\)](#) ▶ 32

with internal absorbers

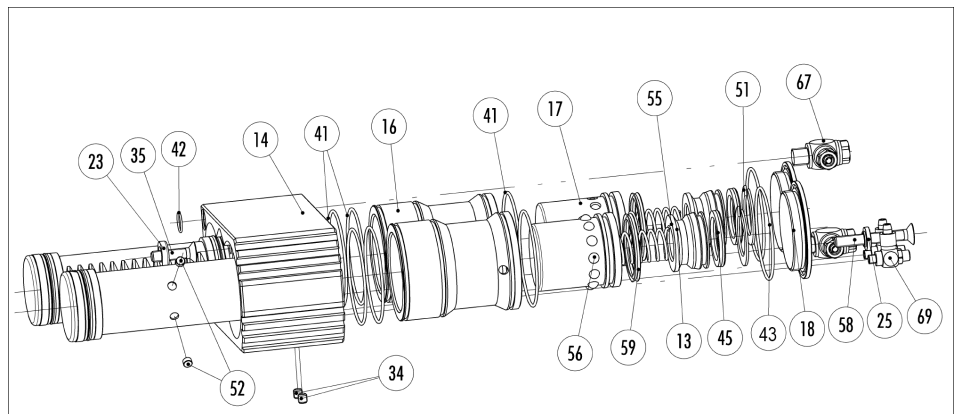

- Unscrew the countersunk screw (35) on stops C and D by one turn.
- Remove the countersunk screw (58).
- Unscrew stops C and D until the centering housing (14) can be removed.
- Remove the safety rings (50).
- Pull out the shock absorber (54).

NOTICE

During mounting, it is possible to damage the O-rings (41).

- Mount the shock absorbers carefully.

- Insert the new shock absorbers. **CAUTION:** Note the shock absorber distance [Measuring instruction \[▶ 42\]](#); if need be, insert or remove the fitting disks.
- Add fitting discs to the safety rings until they can be mounted without play.

7.4.1 How to use the shock absorbers and installation dimensions

SRU	Base			Locked centre position		
	Shock absorber	Overhang of the shock absorber		Shock absorber	Overhang of the shock absorber	
20,1	MC 150 MH2	Measuring instruction [▶ 42]	±0,1			
20,2	MC 150 MH2		±0,1	MC 150 MH2	Measuring instruction [▶ 42]	±0,1
25,1	MC 150 MH2		±0,1			
25,2	WP-M 0.25-456	9,2	±0,05	MC 150 MH2	Measuring instruction [▶ 42]	±0,1
35,1	MC 225 MH2	Measuring instruction [▶ 42]	±0,1			
35,2	MC 225 MH2		±0,1	MC 225 MH2	Measuring instruction [▶ 42]	±0,1
40,1	MC 600 MH		±0,1			
40,2	Mc 600 MH2		±0,1	MC 600 MH2	Measuring instruction [▶ 42]	±0,1
50,1	Mc 600 MH2		±0,1			
50,2	WP-M 1.0-166	17,5	±0,05	MC 600 MH2	Measuring instruction [▶ 42]	±0,1
60,1	WP-M 1.0-166	17,5	±0,05			
60,2	WP-M 1.0-166	17,5	±0,05	MC 600 MH2	Measuring instruction [▶ 42]	±0,1

7.4.2 Measuring instruction

Installation is done as follows:

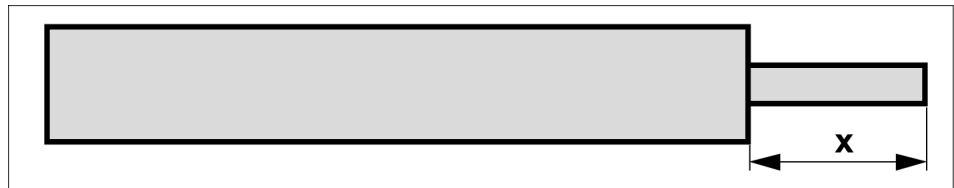

Shock absorber

- Measure the overhang (**x**) of the shock absorber's plunger.

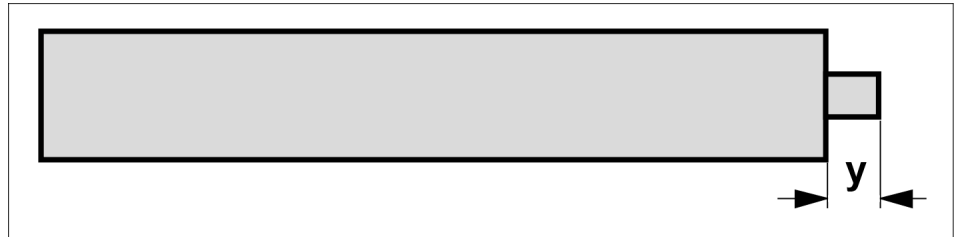

Shock absorber with shock absorber's plunger in pushed-in position

- Measure the overhang (**y**) of the shock absorber's plunger in pushed-in position.

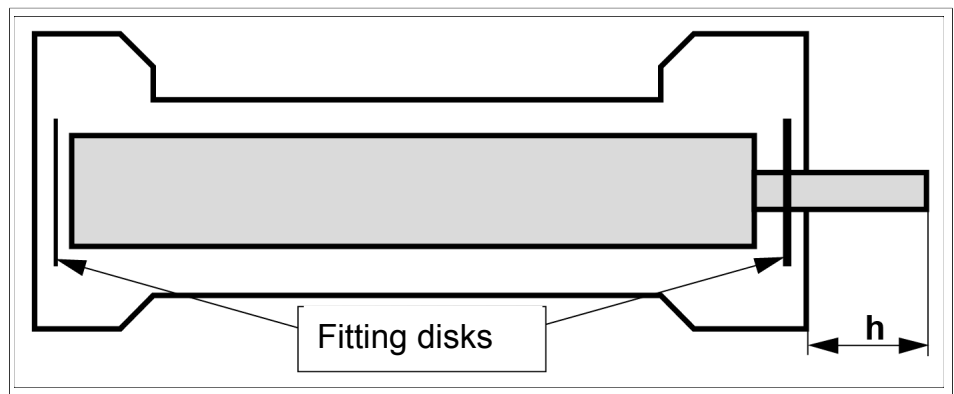

Shock absorber

- Calculate the stroke of the shock absorber (**h**). $h = x - y - 0,2 \text{ mm}$
- Adjust the overhang (**h**) of the shock absorber.

7.5 Servicing the product

Position of the item numbers, [Assembly drawings](#) [▶ 43]

- Clean all parts thoroughly and check for damage and wear.
- Replace all wearing parts and seals.
- Treat all greasing areas with lubricant.
- Oil or grease bare, external steel parts.

7.6 Assembly drawings

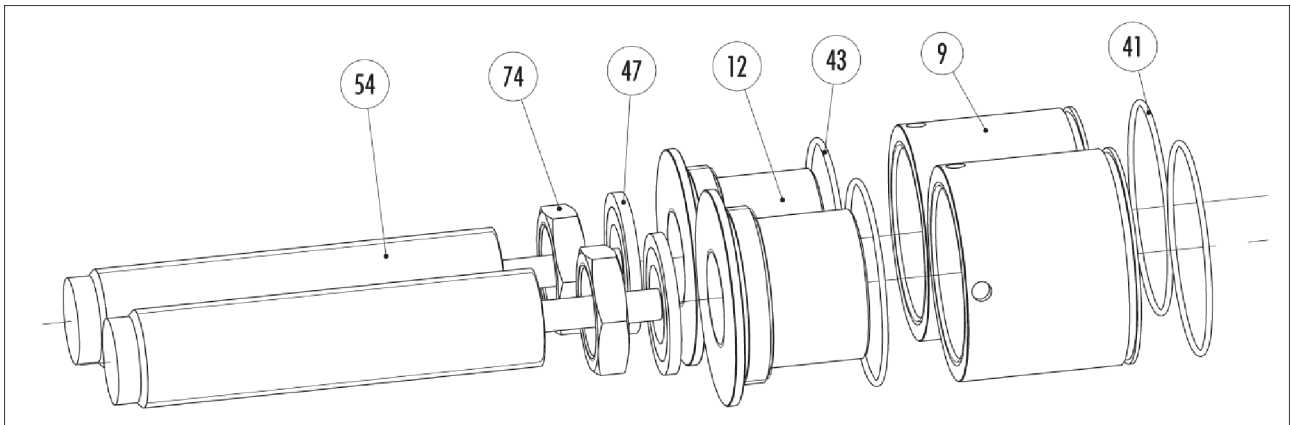

Stop side locked centre position (version VM)

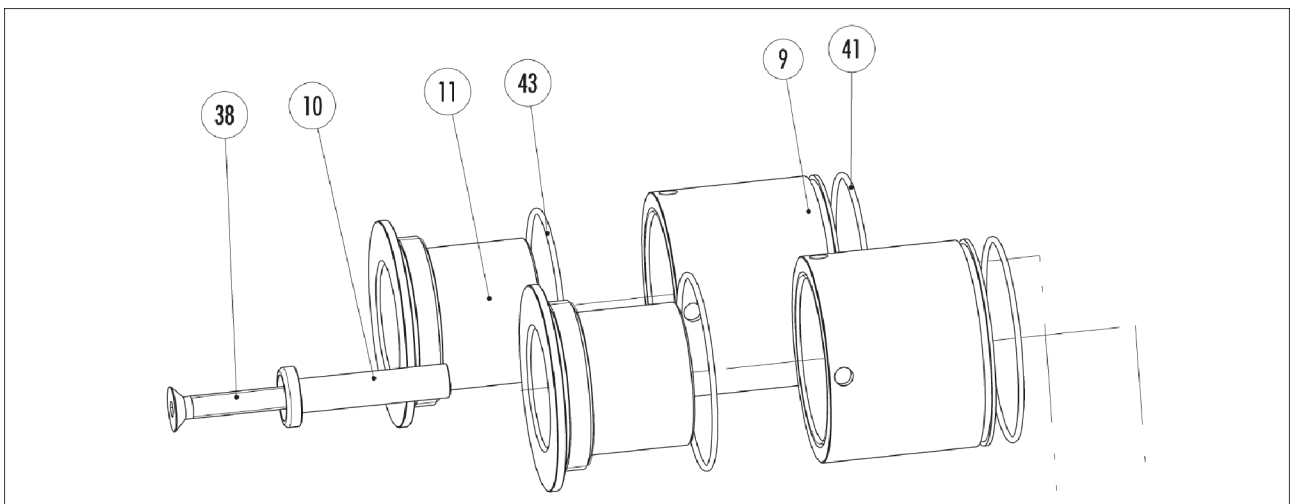

Stop side adjustability of final position 90°

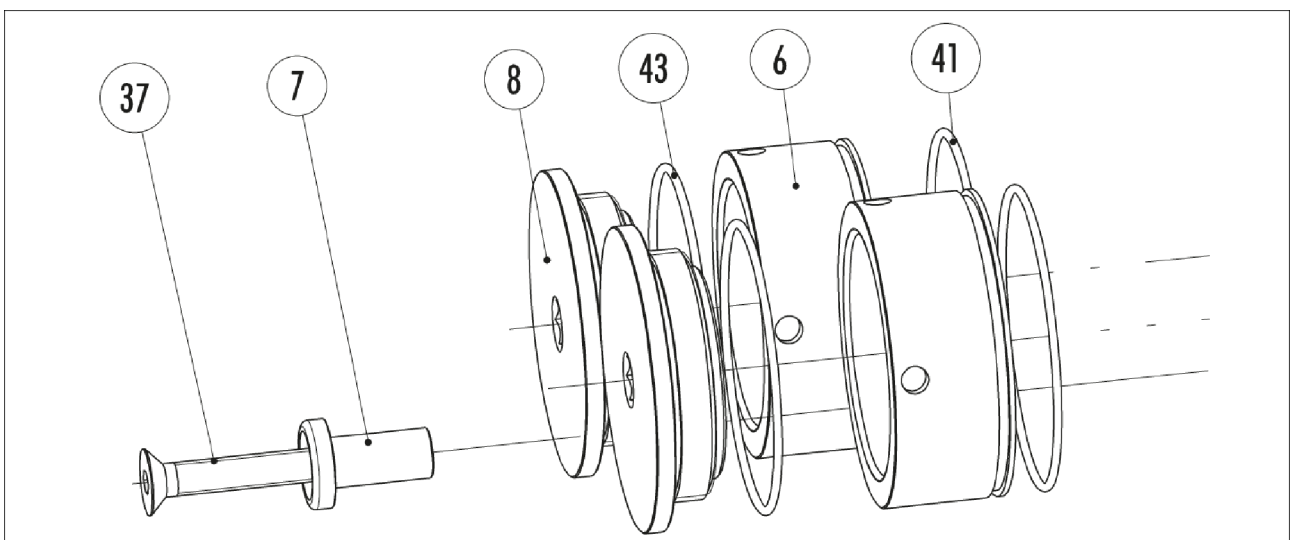

Stop side adjustability of final position 3°

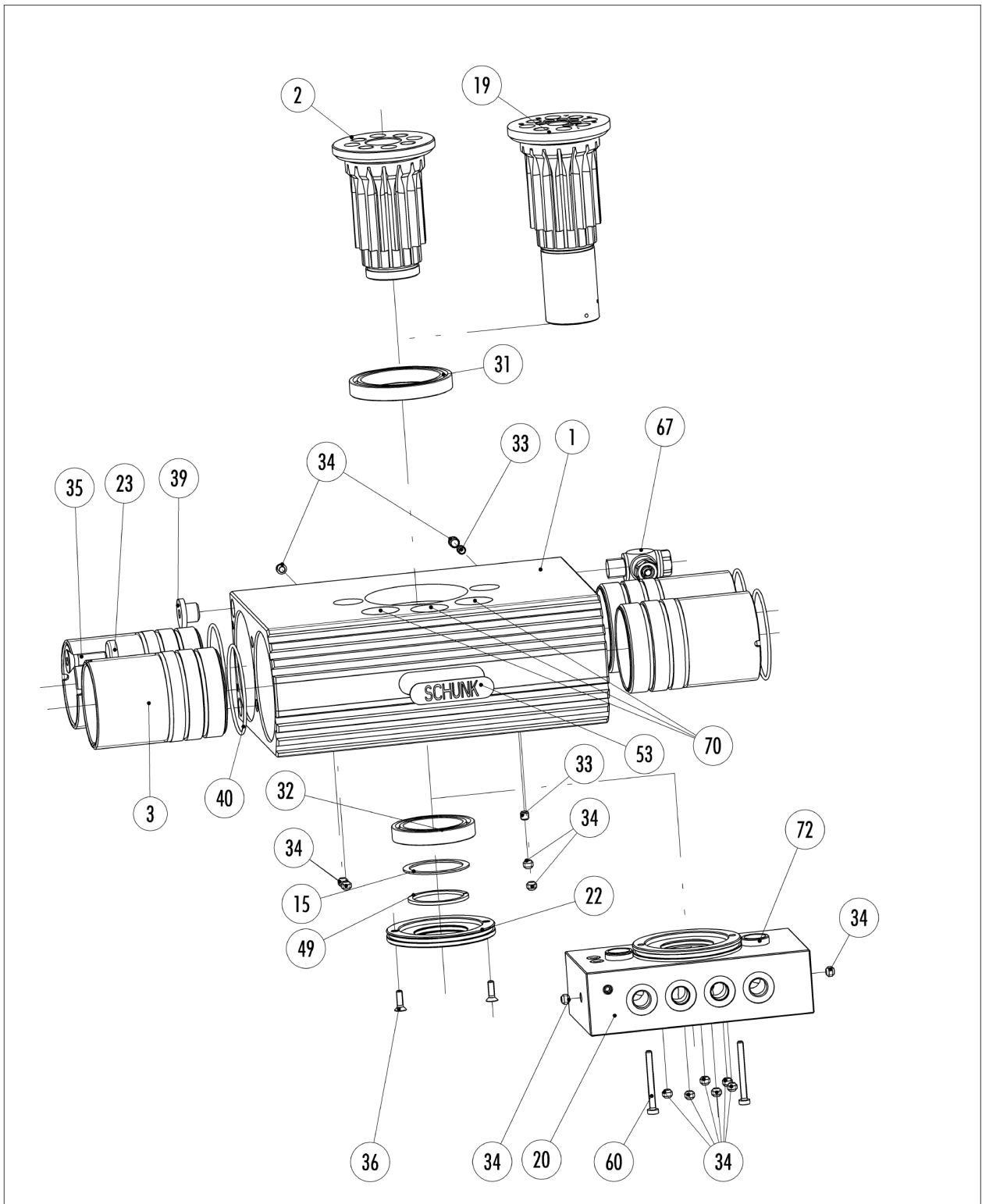

Basic components and media feed through

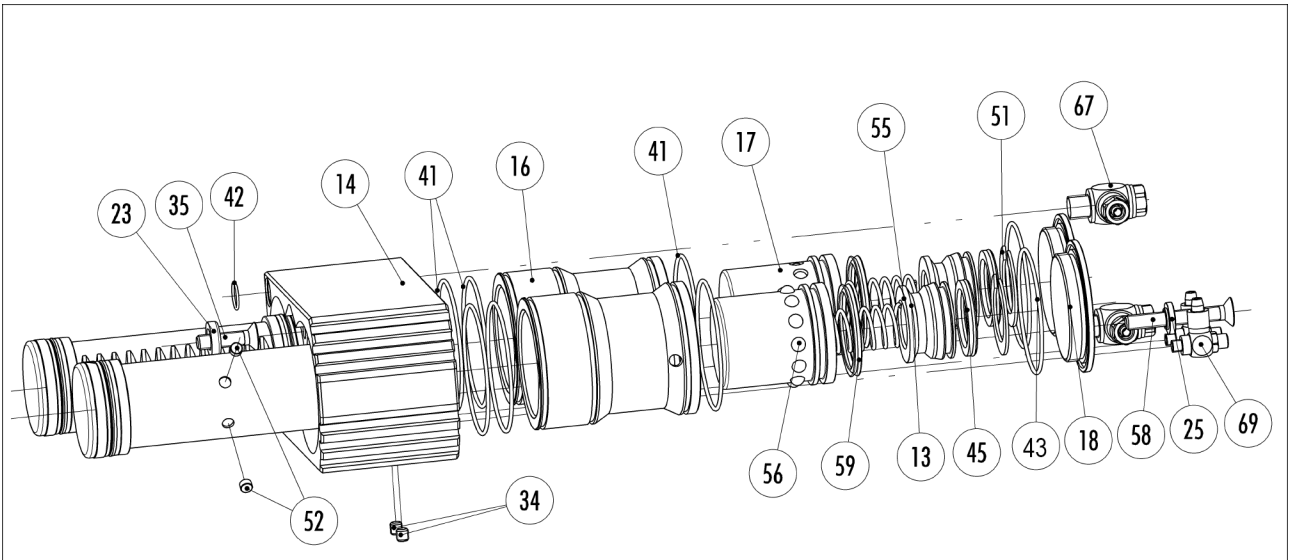

Attachment locked centre position (version VM)

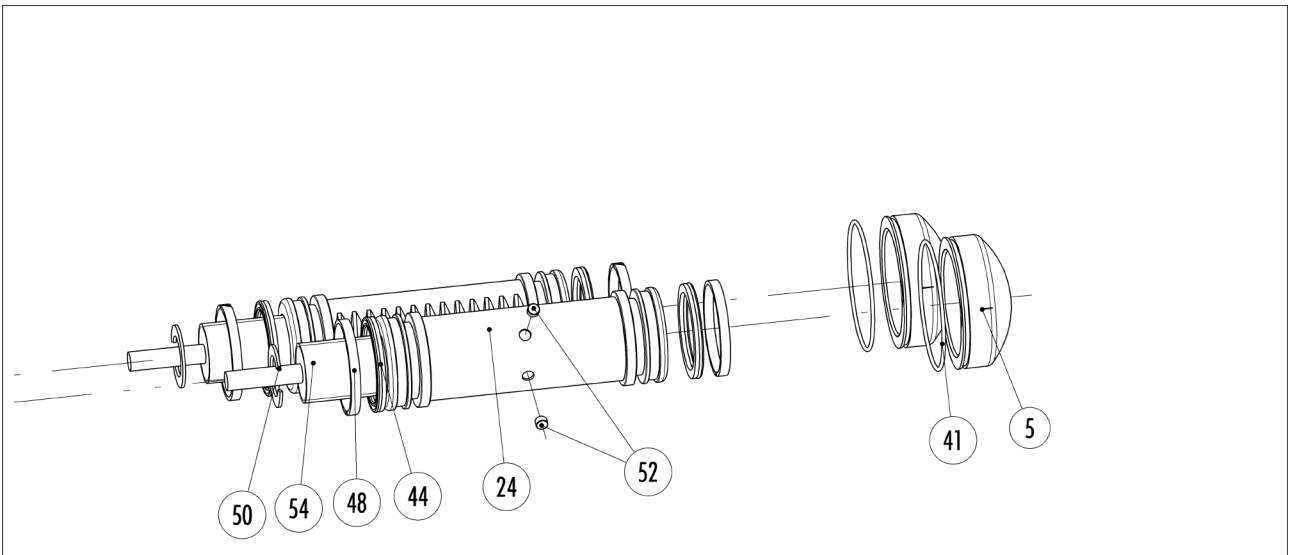

Piston and cover basic unit

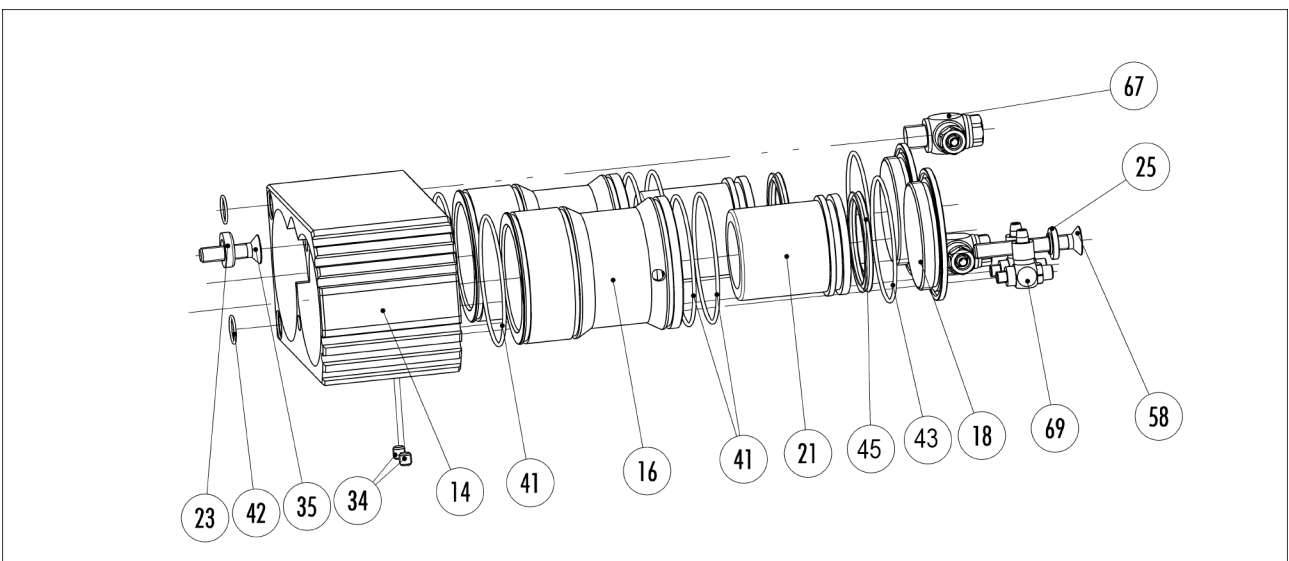

Attachment centre position (version M)

9 Annex to Declaration of Incorporation

according 2006/42/EG, Annex II, No. 1 B

1. Description of the essential health and safety requirements pursuant to 2006/42/EC, Annex I that are applicable and that have been fulfilled with:

Product designation	Pneumatic Swivel Unit
Type designation	SRU
ID number	0357300 ... 0354840

To be provided by the System Integrator for the overall machine	↓
Fulfilled for the scope of the partly completed machine	↓
Not relevant	↓

1.1	Essential Requirements			
1.1.1	Definitions		X	
1.1.2	Principles of safety integration		X	
1.1.3	Materials and products		X	
1.1.4	Lighting		X	
1.1.5	Design of machinery to facilitate its handling		X	
1.1.6	Ergonomics		X	
1.1.7	Operating positions			X
1.1.8	Seating			X

1.2	Control Systems			
1.2.1	Safety and reliability of control systems		X	
1.2.2	Control devices		X	
1.2.3	Starting		X	
1.2.4	Stopping		X	
1.2.4.1	Normal stop		X	
1.2.4.2	Operational stop		X	
1.2.4.3	Emergency stop		X	
1.2.4.4	Assembly of machinery		X	
1.2.5	Selection of control or operating modes		X	
1.2.6	Failure of the power supply			X

1.3	Protection against mechanical hazards			
1.3.1	Risk of loss of stability			X
1.3.2	Risk of break-up during operation			X
1.3.3	Risks due to falling or ejected objects			X
1.3.4	Risks due to surfaces, edges or angles		X	

1.3	Protection against mechanical hazards			
1.3.5	Risks related to combined machinery			X
1.3.6	Risks related to variations in operating conditions			X
1.3.7	Risks related to moving parts		X	
1.3.8	Choice of protection against risks arising from moving parts			X
1.3.8.1	Moving transmission parts		X	
1.3.8.2	Moving parts involved in the process			X
1.3.9	Risks of uncontrolled movements			X
1.4	Required characteristics of guards and protective devices			
1.4.1	General requirements			X
1.4.2	Special requirements for guards			X
1.4.2.1	Fixed guards			X
1.4.2.2	Interlocking movable guards			X
1.4.2.3	Adjustable guards restricting access			X
1.4.3	Special requirements for protective devices			X
1.5	Risks due to other hazards			
1.5.1	Electricity supply		X	
1.5.2	Static electricity		X	
1.5.3	Energy supply other than electricity		X	
1.5.4	Errors of fitting		X	
1.5.5	Extreme temperatures			X
1.5.6	Fire			X
1.5.7	Explosion			X
1.5.8	Noise			X
1.5.9	Vibrations			X
1.5.10	Radiation	X		
1.5.11	External radiation	X		
1.5.12	Laser radiation	X		
1.5.13	Emissions of hazardous materials and substances			X
1.5.14	Risk of being trapped in a machine	X		
1.5.15	Risk of slipping, tripping or falling	X		
1.5.16	Lightning			X
1.6	Maintenance			
1.6.1	Machinery maintenance		X	
1.6.2	Access to operating positions and servicing points		X	
1.6.3	Isolation of energy sources		X	
1.6.4	Operator intervention		X	
1.6.5	Cleaning of internal parts		X	

1.7	Information			
1.7.1	Information and warnings on the machinery		X	
1.7.1.1	Information and information devices		X	
1.7.1.2	Warning devices		X	
1.7.2	Warning of residual risks		X	
1.7.3	Marking of machinery	X		
1.7.4	Instructions	X		
1.7.4.1	General principles for the drafting of instructions	X		
1.7.4.2	Contents of the instructions	X		
1.7.4.3	Sales literature	X		

	The classification from Annex 1 is to be supplemented from here forward.			
2	Supplementary essential health and safety requirements for certain categories of machinery			X
2.1	Foodstuffs machinery and machinery for cosmetics or pharmaceutical products			X
2.2	Portable hand-held and/or guided machinery			X
2.2.1	Portable fixing and other impact machinery			X
2.3	Machinery for working wood and material with similar physical characteristics			X
3	Supplementary essential health and safety requirements to offset hazards due to the mobility of machinery		X	
4	Supplementary essential health and safety requirements to offset hazards due to lifting operations		X	
5	Supplementary essential health and safety requirements for machinery intended for underground work			X
6	Supplementary essential health and safety requirements for machinery presenting particular hazards due to the lifting of persons		X	

