

Assembly and Operating Manual

SLE

Stroke Module



Imprint

Copyright:

This manual is protected by copyright. The author is SCHUNK GmbH & Co. KG. All rights reserved. Any reproduction, processing, distribution (making available to third parties), translation or other usage - even excerpts - of the manual is especially prohibited and requires our written approval.

Technical changes:

We reserve the right to make alterations for the purpose of technical improvement.

Document number: 389409

Version: 03.00 | 03/05/2019 | en

© SCHUNK GmbH & Co. KG

All rights reserved.

Dear Customer,

thank you for trusting our products and our family-owned company, the leading technology supplier of robots and production machines.

Our team is always available to answer any questions on this product and other solutions. Ask us questions and challenge us. We will find a solution!

Best regards,

Your SCHUNK team

SCHUNK GmbH & Co. KG
Spann- und Greiftechnik

Bahnhofstr. 106 – 134
D-74348 Lauffen/Neckar

Tel. +49-7133-103-0

Fax +49-7133-103-2399

info@de.schunk.com

schunk.com

Table of contents

1	General	5
1.1	About this manual	5
1.1.1	Presentation of Warning Labels	5
1.1.2	Applicable documents	6
1.1.3	Sizes	6
1.1.4	Variants.....	6
1.2	Warranty	6
1.3	Scope of delivery	6
2	Basic safety notes	7
2.1	Intended use.....	7
2.2	Not intended use.....	7
2.3	Constructional changes	7
2.4	Spare parts	7
2.5	Ambient conditions and operating conditions	7
2.6	Personnel qualification.....	8
2.7	Personal protective equipment.....	9
2.8	Notes on safe operation	9
2.9	Transport.....	9
2.10	Malfunctions.....	10
2.11	Disposal	10
2.12	Fundamental dangers.....	10
2.12.1	Protection during handling and assembly	10
2.12.2	Protection during commissioning and operation	11
2.12.3	Protection against dangerous movements.....	11
2.12.4	Protection against electric shock.....	12
2.13	Notes on particular risks.....	12
3	Technical data	14
4	Design and description	15
4.1	Operating elements and connections	15
4.2	Function.....	16
5	Assembly	17
5.1	Assembly	17
5.2	Attachment variants.....	18
6	Commissioning	20
7	Maintenance	23
7.1	Maintenance notes.....	23
7.2	Lubrication.....	23
7.2.1	Lubrication intervals	23

Table of contents

7.2.2	Follow-up lubrication.....	23
7.3	Assembly drawing.....	24
8	Translation of original declaration of incorporation	25
8.1	Annex to Declaration of Incorporation.....	26

1 General

1.1 About this manual

This manual contains important information for a safe and appropriate use of the product.

This manual is an integral part of the product and must be kept accessible for the personnel at all times.

Before starting work, the personnel must have read and understood this operating manual. Prerequisite for safe working is the observance of all safety instructions in this manual.

Illustrations in this manual are provided for basic understanding and may differ from the actual product design.

In addition to these instructions, the documents listed under [Applicable documents](#) [► 6] are applicable.

1.1.1 Presentation of Warning Labels

To make risks clear, the following signal words and symbols are used for safety notes.



⚠ DANGER

Danger for persons!

Non-observance will inevitably cause irreversible injury or death.



⚠ WARNING

Dangers for persons!

Non-observance can lead to irreversible injury and even death.



⚠ CAUTION

Dangers for persons!

Non-observance can cause minor injuries.

NOTICE

Material damage!

Information about avoiding material damage.

1.1.2 Applicable documents

- General terms of business*
- Catalog data sheet of the purchased product *

The documents marked with an asterisk (*) can be downloaded on our homepage **schunk.com**

1.1.3 Sizes

This operating manual applies to the following sizes:

- SLE 25
- SLE 32
- SLE 50

1.1.4 Variants

This operating manual applies to the following variations:

- SLE 25
 - Stroke length [mm]: 40, 80, 125, 160, 200
- SLE 32 and 50
 - Stroke length [mm]: 80, 125, 160, 200, 250
 - With rod lock
 - Without rod lock

1.2 Warranty

If the product is used as intended, the warranty is valid for 24 months from the ex-works delivery date under the following conditions:

- Observe the specified maintenance and lubrication intervals
- Observe the ambient conditions and operating conditions

Parts touching the workpiece and wear parts are not included in the warranty.

1.3 Scope of delivery

The scope of delivery includes

- Stroke Module SLE in the version ordered

2 Basic safety notes

2.1 Intended use

The product is exclusively designed for linear movement of useful loads into any desired position.

- The product may only be used within the scope of its technical data, [Technical data](#) [▶ 14].
- When implementing and operating components in safety-related parts of the control systems, the basic safety principles in accordance with DIN EN ISO 13849-2 apply. The proven safety principles in accordance with DIN EN ISO 13849-2 also apply to categories 1, 2, 3 and 4.
- The product is intended for installation in a machine/system. The applicable guidelines must be observed and complied with.
- The product is intended for industrial and industry-oriented use.
- Appropriate use of the product includes compliance with all instructions in this manual.

2.2 Not intended use

It is not intended use if the product is used, for example, as a pressing tool, stamping tool, lifting gear, guide for tools, cutting tool, clamping device or a drilling tool.

- Any utilization that exceeds or differs from the appropriate use is regarded as misuse.

2.3 Constructional changes

Implementation of structural changes

By conversions, changes, and reworking, e.g. additional threads, holes, or safety devices can impair the functioning or safety of the product or damage it.

- Structural changes should only be made with the written approval of SCHUNK.

2.4 Spare parts

Use of unauthorized spare parts

Using unauthorized spare parts can endanger personnel and damage the product or cause it to malfunction.

- Use only original spare parts or spares authorized by SCHUNK.

2.5 Ambient conditions and operating conditions

Required ambient conditions and operating conditions

Incorrect ambient and operating conditions can make the product unsafe, leading to the risk of serious injuries, considerable material damage and/or a significant reduction to the product's life span.

- Make sure that the product is used only in the context of its defined application parameters, [Technical data](#) [▶ 14].

2.6 Personnel qualification

Inadequate qualifications of the personnel

If the personnel working with the product is not sufficiently qualified, the result may be serious injuries and significant property damage.

- All work may only be performed by qualified personnel.
- Before working with the product, the personnel must have read and understood the complete assembly and operating manual.
- Observe the national safety regulations and rules and general safety instructions.

The following personal qualifications are necessary for the various activities related to the product:

Trained electrician	Due to their technical training, knowledge and experience, trained electricians are able to work on electrical systems, recognize and avoid possible dangers and know the relevant standards and regulations.
Qualified personnel	Due to its technical training, knowledge and experience, qualified personnel is able to perform the delegated tasks, recognize and avoid possible dangers and knows the relevant standards and regulations.
Instructed person	Instructed persons were instructed by the operator about the delegated tasks and possible dangers due to improper behaviour.
Service personnel of the manufacturer	Due to its technical training, knowledge and experience, service personnel of the manufacturer is able to perform the delegated tasks and to recognize and avoid possible dangers.

2.7 Personal protective equipment

Use of personal protective equipment

Personal protective equipment serves to protect staff against danger which may interfere with their health or safety at work.

- When working on and with the product, observe the occupational health and safety regulations and wear the required personal protective equipment.
- Observe the valid safety and accident prevention regulations.
- Wear protective gloves to guard against sharp edges and corners or rough surfaces.
- Wear heat-resistant protective gloves when handling hot surfaces.
- Wear protective gloves and safety goggles when handling hazardous substances.
- Wear close-fitting protective clothing and also wear long hair in a hairnet when dealing with moving components.

2.8 Notes on safe operation

Incorrect handling of the personnel

Incorrect handling and assembly may impair the product's safety and cause serious injuries and considerable material damage.

- Avoid any manner of working that may interfere with the function and operational safety of the product.
- Use the product as intended.
- Observe the safety notes and assembly instructions.
- Do not expose the product to any corrosive media. This does not apply to products that are designed for special environments.
- Eliminate any malfunction immediately.
- Observe the care and maintenance instructions.
- Observe the current safety, accident prevention and environmental protection regulations regarding the product's application field.

2.9 Transport

Handling during transport

Incorrect handling during transport may impair the product's safety and cause serious injuries and considerable material damage.

- When handling heavy weights, use lifting equipment to lift the product and transport it by appropriate means.
- Secure the product against falling during transportation and handling.
- Stand clear of suspended loads.

2.10 Malfunctions

Behavior in case of malfunctions

- Immediately remove the product from operation and report the malfunction to the responsible departments/persons.
- Order appropriately trained personnel to rectify the malfunction.
- Do not recommission the product until the malfunction has been rectified.
- Test the product after a malfunction to establish whether it still functions properly and no increased risks have arisen.

2.11 Disposal

Handling of disposal

The incorrect handling of disposal may impair the product's safety and cause serious injuries as well as considerable material and environmental harm.

- Follow local regulations on dispatching product components for recycling or proper disposal.

2.12 Fundamental dangers

General

- Observe safety distances.
- Never deactivate safety devices.
- Before commissioning the product, take appropriate protective measures to secure the danger zone.
- Disconnect power sources before installation, modification, maintenance, or calibration. Ensure that no residual energy remains in the system.
- If the energy supply is connected, do not move any parts by hand.
- Do not reach into the open mechanism or movement area of the product during operation.

2.12.1 Protection during handling and assembly

Incorrect handling and assembly

Incorrect handling and assembly may impair the product's safety and cause serious injuries and considerable material damage.

- Have all work carried out by appropriately qualified personnel.
- For all work, secure the product against accidental operation.
- Observe the relevant accident prevention rules.
- Use suitable assembly and transport equipment and take precautions to prevent jamming and crushing.

Incorrect lifting of loads

Falling loads may cause serious injuries and even death.

- Stand clear of suspended loads and do not step into their swiveling range.
- Never move loads without supervision.
- Do not leave suspended loads unattended.

2.12.2 Protection during commissioning and operation

Falling or violently ejected components

Falling and violently ejected components can cause serious injuries and even death.

- Take appropriate protective measures to secure the danger zone.
- Never step into the danger zone during operation.

2.12.3 Protection against dangerous movements

Unexpected movements

Residual energy in the system may cause serious injuries while working with the product.

- Switch off the energy supply, ensure that no residual energy remains and secure against inadvertent reactivation.
- Never rely solely on the response of the monitoring function to avert danger. Until the installed monitors become effective, it must be assumed that the drive movement is faulty, with its action being dependent on the control unit and the current operating condition of the drive. Perform maintenance work, modifications, and attachments outside the danger zone defined by the movement range.
- To avoid accidents and/or material damage, human access to the movement range of the machine must be restricted. Limit/prevent accidental access for people in this area due through technical safety measures. The protective cover and protective fence must be rigid enough to withstand the maximum possible movement energy. EMERGENCY STOP switches must be easily and quickly accessible. Before starting up the machine or automated system, check that the EMERGENCY STOP system is working. Prevent operation of the machine if this protective equipment does not function correctly.

2.12.4 Protection against electric shock

Possible electrostatic energy

Components or assembly groups may become electrostatically charged. When the electrostatic charge is touched, the discharge may trigger a shock reaction leading to injuries.

- The operator must ensure that all components and assembly groups are included in the local potential equalisation in accordance with the applicable regulations.
- While paying attention to the actual conditions of the working environment, the potential equalisation must be implemented by a specialist electrician according to the applicable regulations.
- The effectiveness of the potential equalisation must be verified by executing regular safety measurements.

2.13 Notes on particular risks



⚠ WARNING

Risk of injury from objects falling and being ejected!

Falling and ejected objects during operation can lead to serious injury or death.

- Take appropriate protective measures to secure the danger zone.



⚠ WARNING

Risk of injury due to unexpected movements!

If the power supply is switched on or residual energy remains in the system, components can move unexpectedly and cause serious injuries.

- Before starting any work on the product: Switch off the power supply and secure against restarting.
- Make sure, that no residual energy remains in the system.



⚠ WARNING

Danger of crushing and impacts during movement of the unit or attachments. Risk of injury due to attachments breaking or becoming loose.

Surround the unit with a protective barrier during operation.

**⚠ WARNING****Risk of injury from uncontrolled movements!**

In the event of a power failure or control system malfunction, components may move uncontrollably and cause serious injuries.

- Secure the product with pressure maintenance valves (e.g. SCHUNK pressure maintenance valves SDV-P for short time holding of every end position).

**⚠ WARNING****Risk of burns through contact with hot surfaces!**

The product can heat up considerably during operation. Touching hot surfaces can cause burns.

- Do not touch hot surfaces.
- Let them cool down before working on the product.
- Wear appropriate safety equipment.

3 Technical data

Dynamic values

Horizontal	
Max. acceleration [mm/s ²]	5
Max. speed [mm/s]	1
Vertical	
Max. acceleration [mm/s ²]	2
Max. speed [mm/s]	0,25

Ambient conditions and operating conditions

Ambient temperature [°C]	
min.	+5
max.	+60
Noise emission [dB(A)]	≤ 70

More technical data is included in the catalog data sheet.
Whichever is the latest version.

4 Design and description

4.1 Operating elements and connections

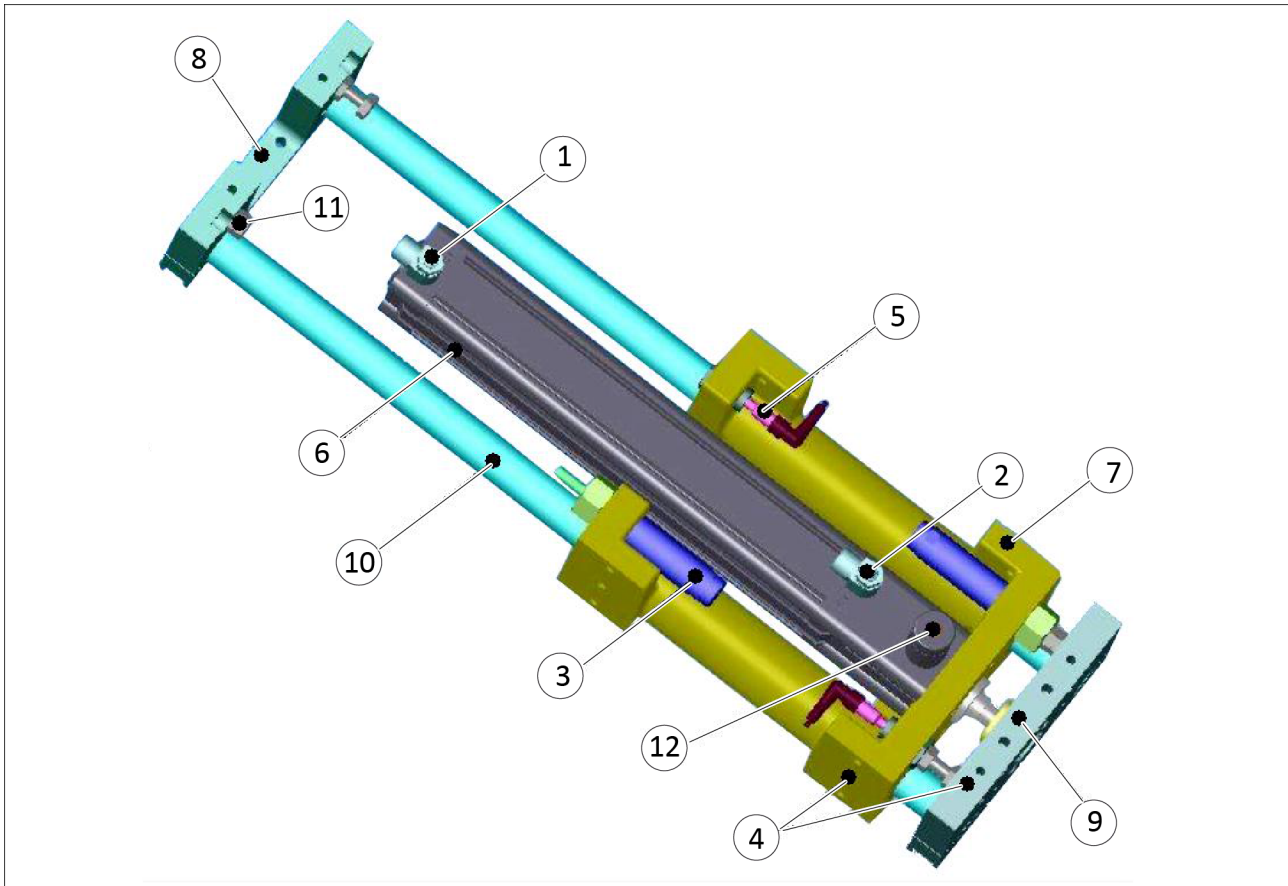

SLE design

1	Compressed air connection (extending)	7	Slide
2	Compressed air connection (retracting)	8	Rear panel
3	Hydraulic shock absorber	9	Front panel
4	Threaded and pin holes	10	Guide shaft
5	Proximity switch	11	Adjustable stroke limitation
6	Pneumatic drive	12	Rod lock (optional)

4.2 Function

The SLE linear unit is a pneumatically driven device that is guided on a rolling element with minimal play.

The guide shafts or the slide (depending on mode of attachment) are moved back and forth by alternating air-bleeding of the compressed air connections. This movement is braked at the adjustable end positions by hydraulic shock absorbers.

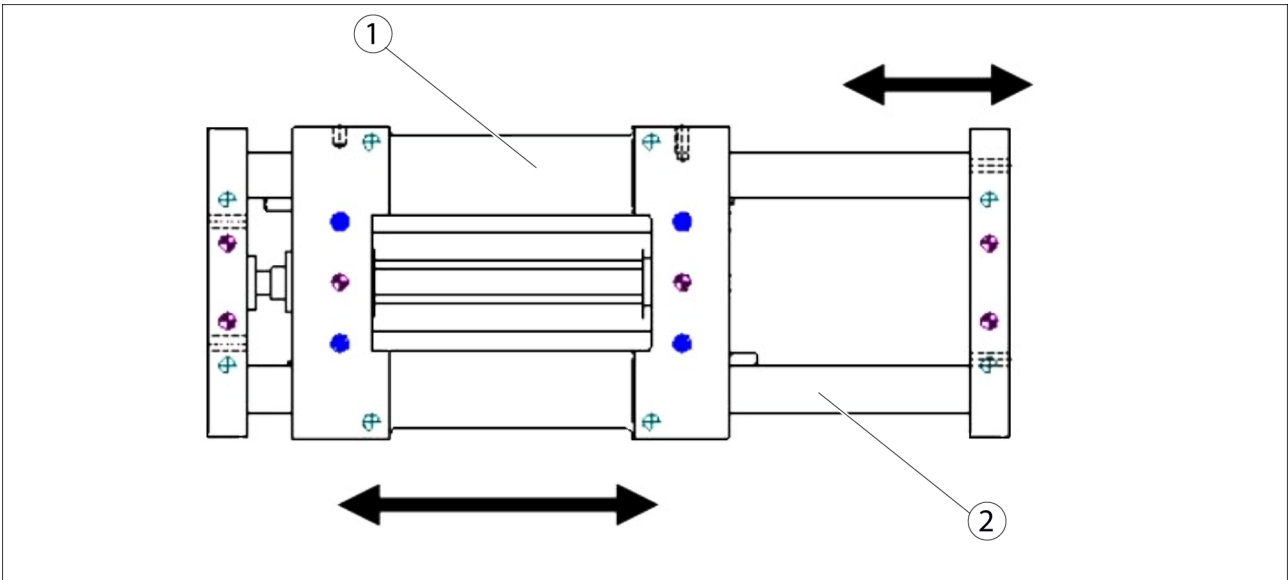

Direction of motion

Item	Description	Note
1	Slide	In movement depending on mode of attachment
2	Guide shafts with the connected front and rear panel	In movement depending on mode of attachment

5 Assembly

5.1 Assembly



⚠ WARNING

Risk of injury from falling down the unit!

The product weighs up to 18kg.

- Secure the product during transport and assembly with adequately sized straps.
 - Anzugsmomente der Befestigungsschrauben beachten.
-
- Handle the SLE in such a way that damage to the slide guides are avoided. Damage causes reduced rolling-contact bearing function.
 - Modifications to screws and nuts are impermissible, except on the screw for the adjustable stroke limitation.
 - Ensure that there is sufficient space for the pneumatic connections, for the setting elements and for possible shock absorber replacement.
 - Ensure distortion-free installation.

5.2 Attachment variants

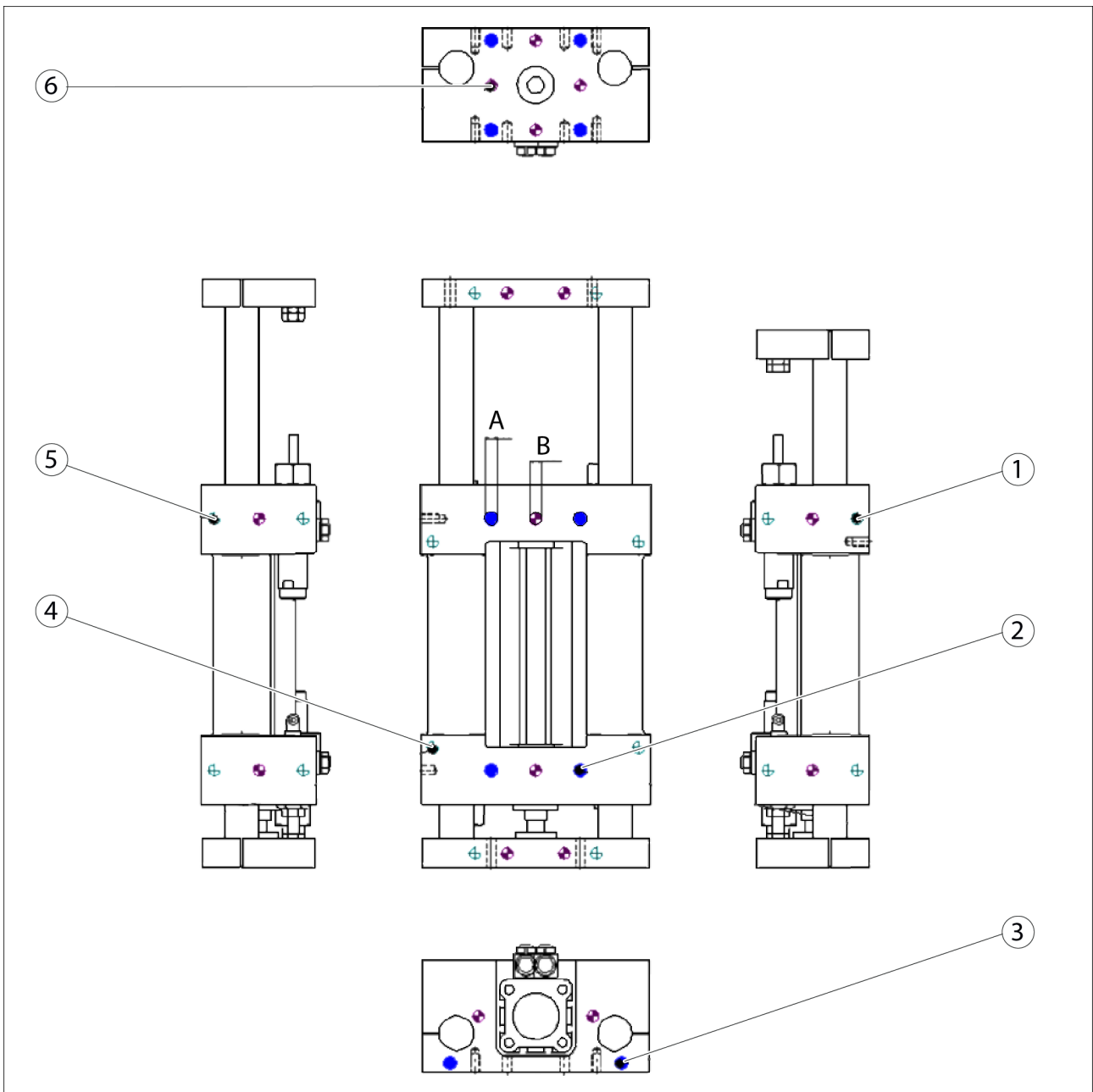

Bore holes and threads

Item	Attachment variants	Note
1	Lateral	Thread
2	Front	Borehole
3	Rear panel	Borehole
4	Rear	Thread
5	Lateral	Thread
6	Front panel	Borehole
A	Ø5, Ø6.6 or Ø9	Depending on size
B	Ø6 ^{H7} or Ø8 ^{H7}	Depending on size

- Use the one-way flow control valves on the pneumatic connections to set the slide speed. This is done by turning the set-screw (with slit).
- When using or replacing proximity switches, ensure that they do not project (damage would be the result) and are not turned back too far (no switching signal). Basic factory setting 0.5 mm behind the hexagon end face.

Note when installing vertically

- Ensure that the slide reaches a stable position when it has come to a standstill (e.g. lowest point or securing with moved bolts).
- Avoid sudden downward hitting of the slide (e.g. by optional use of the rod lock on the pneumatic drive).

6 Commissioning



⚠ WARNING

Risk of injury when the machine/system moves unexpectedly due to movement of the axes!

Remove the energy supplies before starting with assembly and adjustments.

Make sure that no residual energy remains in the system.

In the SLE travel area, ensure that

- nobody reaches into the slide's running direction (e.g. by installing protective grille).
- there are no foreign objects.
- reaching into the SLE is only possible when the movable mass has come to a complete standstill.

NOTICE

Danger of mechanical destruction

Thread could be destroyed.

- Note minimal depth of engagement $1 \times d$ (e.g. $1 \times (M) 8 = 8 \text{ mm}$).

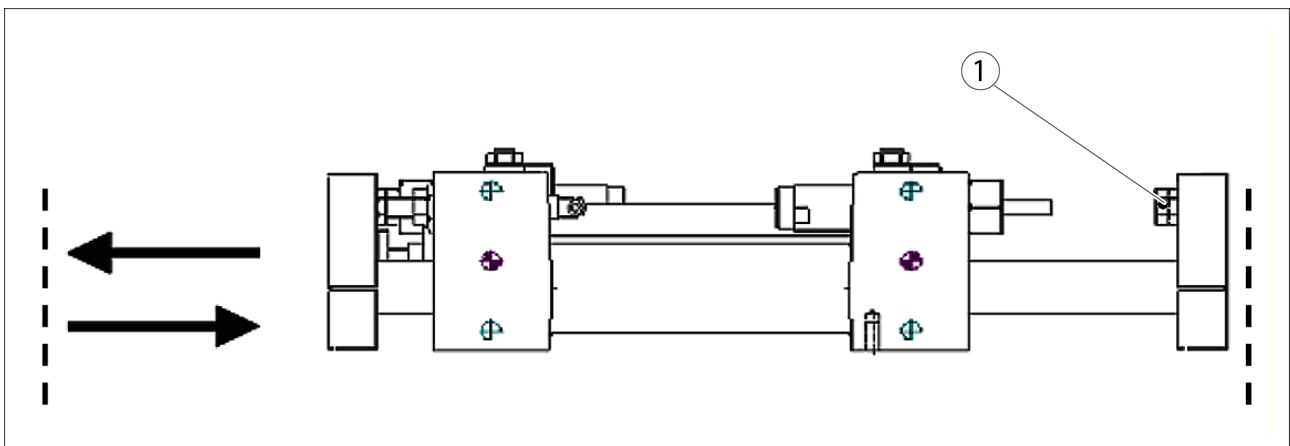

Setting the stroke limitation

1	adjustable stroke limitation
---	------------------------------

Setting the stroke limitation

- Loosening the counter-nut.
- Turn hexagon screw until the slide is set to the desired end position.
- Tighten counter-nut.
- Repeat procedure on the other side.

If the stroke needs to be limited even further, use longer screws.

Further procedure

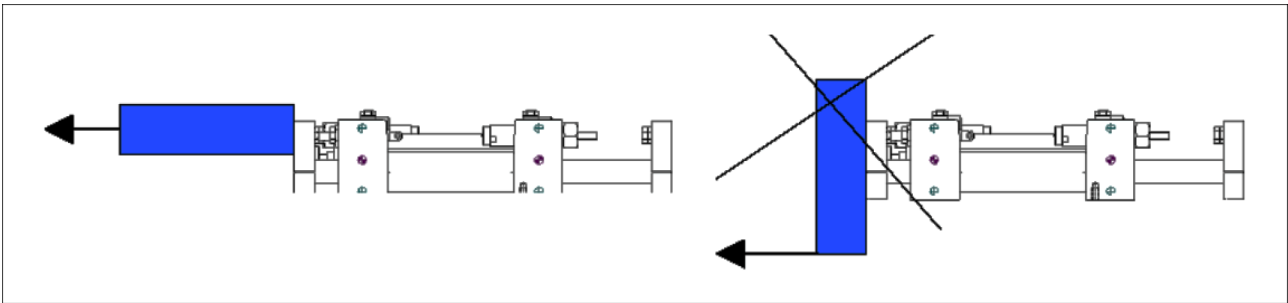

Placing useful load

- Place the useful load onto the slide in such a way that the overturning moment remains as small as possible.
 - Close both upstream throttle check valves completely, then turn once to open again.
 - Ensure that the operating conditions mentioned before are within the permissible range.
 - Air-bleed the pneumatic drive by slowly air-bleeding on one side. Slide travels to end position - slowly air-bleed the entire system so as to avoid uncontrollable movements.
- Test run with the moved mass**
- In the test run, test whether the following points need to be modified:
 - ✓ the speed and acceleration of the moveable mass
 - ✓ the end position
 - ✓ the mass of the useful load
 - ✓ the position of the proximity switches

NOTE

Put the slide out of operation before modifying any of the above mentioned features.

- Slowly open the throttle check valve again until the desired slide speed is set. The slide should reach the end position safely but not hit it hard.

If the slide audibly hits the end position:

- Mass moment of inertia of the moveable mass is too high
- Slide speed is too high
- Hydraulic shock absorber is defective
- Interrupt the test run

Remedy the above stated causes. Repeat test run.

Note when installing vertically

- Ensure that the slide reaches a stable position when it has come to a standstill (e.g. lowest point or securing with moved bolts).
- Avoid sudden downward hitting of the mass (e.g. by optional use of the rod lock on the pneumatic drive).

7 Maintenance

7.1 Maintenance notes

- Depressurize the SLE unit before cleaning and lubrication.
- The guidance of the SLE unit is lubricated prior to delivery.
- Maintenance can be done by yourself.
- When replacing parts or for sealreplacement, send the complete SLE with a repair order to SCHUNK.

7.2 Lubrication

7.2.1 Lubrication intervals

Maintenance- and lubrication interval	Note
every 5 million switching cycles	Lubrication is performed after the guide shafts have been cleaned

Check necessity of shorter lubrication intervals in the following cases:

- high temperature impact
- heavy contamination
- use in the proximity of degreasing liquids or vapors

7.2.2 Follow-up lubrication

Perform follow-up lubrications as follows:

- Dismantle front panel.
- Undo clamping.
- Pull the two guide shafts and rear panel out of the slide. Now the four guide bushings in the slide are accessible.
- Lubricate the inside of the four guide bushings with KP2K grease (as per DIN 51825).
- Distribute the grease in the slide by carefully moving the guide shafts back and forth.
- Place the two guide shafts and rear panel back into their positions.
- Replace clamping.
- Assemble front panel.

Further procedure is described in the chapter "Commissioning" [Commissioning](#) [▶ 20].

7.3 Assembly drawing

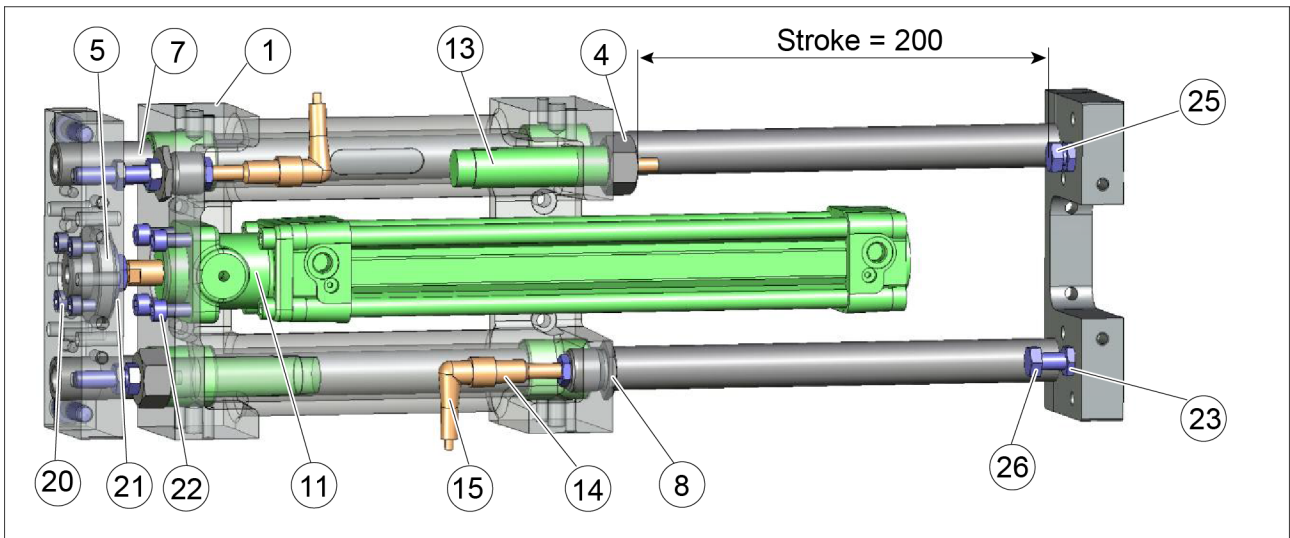

Front view

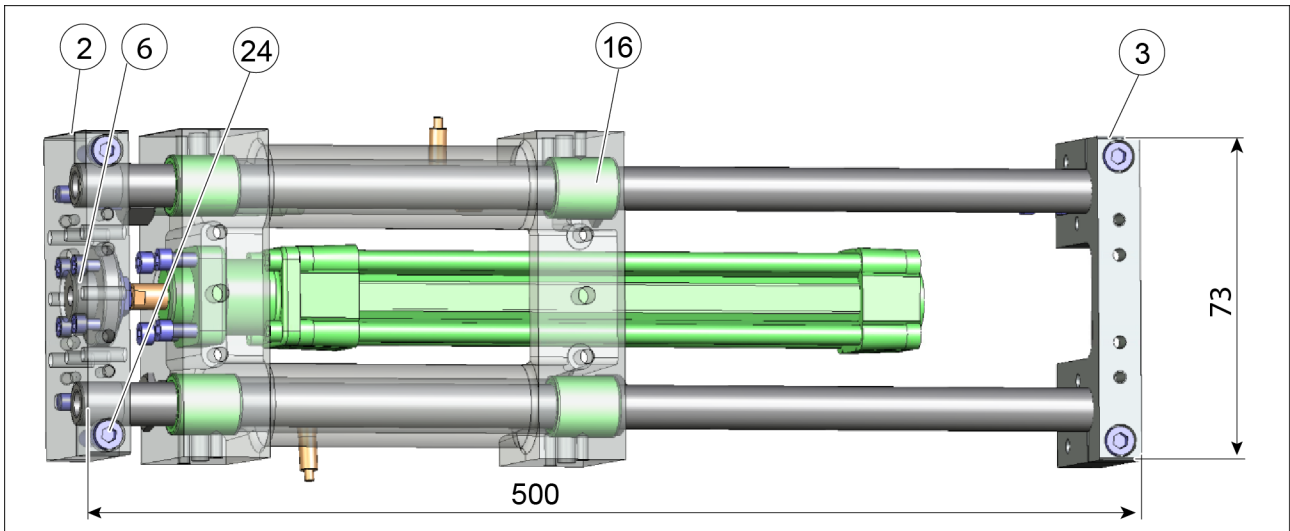

Rear view

8.1 Annex to Declaration of Incorporation

according 2006/42/EG, Annex II, No. 1 B

1. Description of the essential health and safety requirements pursuant to 2006/42/EC, Annex I that are applicable and that have been fulfilled with:

Product designation	Stroke Module
Type designation	SLE
ID number	0331900, 0331901, 0331902, 0331903, 0331904, 0331910, 0331911, 0331912, 0331913, 0331914

To be provided by the System Integrator for the overall machine	↓
Fulfilled for the scope of the partly completed machine	↓
Not relevant	↓

1.1	Essential Requirements			
1.1.1	Definitions		X	
1.1.2	Principles of safety integration		X	
1.1.3	Materials and products		X	
1.1.4	Lighting		X	
1.1.5	Design of machinery to facilitate its handling		X	
1.1.6	Ergonomics		X	
1.1.7	Operating positions			X
1.1.8	Seating			X

1.2	Control Systems			
1.2.1	Safety and reliability of control systems		X	
1.2.2	Control devices		X	
1.2.3	Starting		X	
1.2.4	Stopping		X	
1.2.4.1	Normal stop		X	
1.2.4.2	Operational stop		X	
1.2.4.3	Emergency stop		X	
1.2.4.4	Assembly of machinery		X	
1.2.5	Selection of control or operating modes		X	
1.2.6	Failure of the power supply			X

1.3	Protection against mechanical hazards			
1.3.1	Risk of loss of stability			X
1.3.2	Risk of break-up during operation			X
1.3.3	Risks due to falling or ejected objects			X
1.3.4	Risks due to surfaces, edges or angles		X	
1.3.5	Risks related to combined machinery			X

1.3	Protection against mechanical hazards			
1.3.6	Risks related to variations in operating conditions			X
1.3.7	Risks related to moving parts		X	
1.3.8	Choice of protection against risks arising from moving parts			X
1.3.8.1	Moving transmission parts		X	
1.3.8.2	Moving parts involved in the process			X
1.3.9	Risks of uncontrolled movements			X
1.4	Required characteristics of guards and protective devices			
1.4.1	General requirements			X
1.4.2	Special requirements for guards			X
1.4.2.1	Fixed guards			X
1.4.2.2	Interlocking movable guards			X
1.4.2.3	Adjustable guards restricting access			X
1.4.3	Special requirements for protective devices			X
1.5	Risks due to other hazards			
1.5.1	Electricity supply		X	
1.5.2	Static electricity		X	
1.5.3	Energy supply other than electricity		X	
1.5.4	Errors of fitting		X	
1.5.5	Extreme temperatures			X
1.5.6	Fire			X
1.5.7	Explosion			X
1.5.8	Noise			X
1.5.9	Vibrations			X
1.5.10	Radiation	X		
1.5.11	External radiation	X		
1.5.12	Laser radiation	X		
1.5.13	Emissions of hazardous materials and substances			X
1.5.14	Risk of being trapped in a machine	X		
1.5.15	Risk of slipping, tripping or falling	X		
1.5.16	Lightning			X
1.6	Maintenance			
1.6.1	Machinery maintenance		X	
1.6.2	Access to operating positions and servicing points		X	
1.6.3	Isolation of energy sources		X	
1.6.4	Operator intervention		X	
1.6.5	Cleaning of internal parts		X	

Translation of original declaration of incorporation

1.7	Information			
1.7.1	Information and warnings on the machinery		X	
1.7.1.1	Information and information devices		X	
1.7.1.2	Warning devices		X	
1.7.2	Warning of residual risks		X	
1.7.3	Marking of machinery	X		
1.7.4	Instructions	X		
1.7.4.1	General principles for the drafting of instructions	X		
1.7.4.2	Contents of the instructions	X		
1.7.4.3	Sales literature	X		
	The classification from Annex 1 is to be supplemented from here forward.			
2	Supplementary essential health and safety requirements for certain categories of machinery			X
2.1	Foodstuffs machinery and machinery for cosmetics or pharmaceutical products			X
2.2	Portable hand-held and/or guided machinery			X
2.2.1	Portable fixing and other impact machinery			X
2.3	Machinery for working wood and material with similar physical characteristics			X
3	Supplementary essential health and safety requirements to offset hazards due to the mobility of machinery		X	
4	Supplementary essential health and safety requirements to offset hazards due to lifting operations		X	
5	Supplementary essential health and safety requirements for machinery intended for underground work			X
6	Supplementary essential health and safety requirements for machinery presenting particular hazards due to the lifting of persons		X	