

LINEAR MOTOR DRIVE

MLD type T

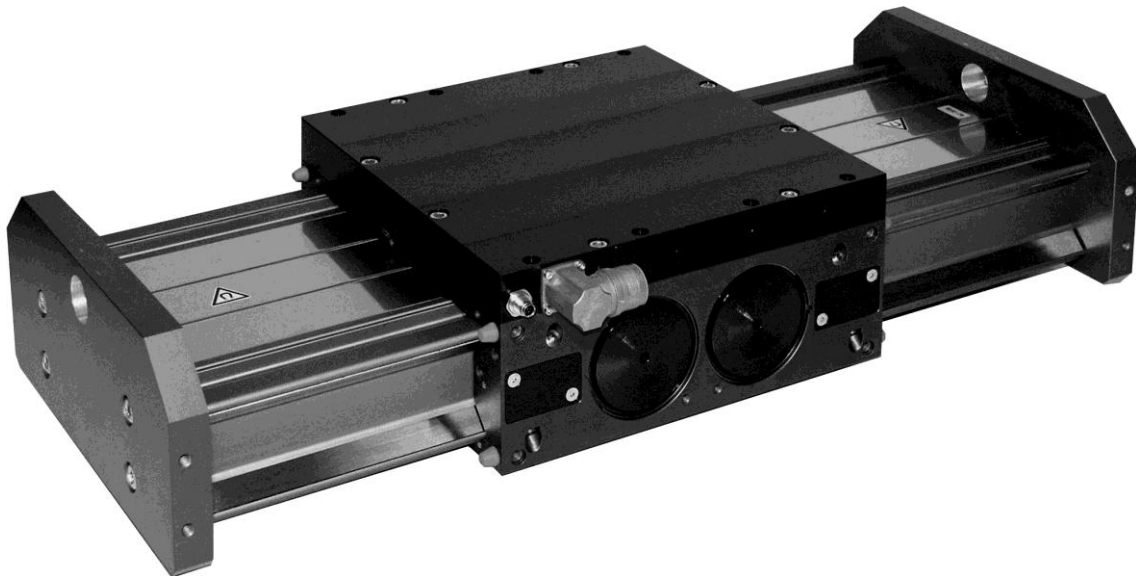

Dear Customer,

Congratulations on choosing a SCHUNK product. By choosing SCHUNK, you have opted for the highest precision, top quality and best service.

You are going to increase the process reliability of your production and achieve best machining results – to the customer's complete satisfaction.

SCHUNK products are inspiring.

Our detailed assembly and operation manual will support you.

Do you have further questions? You may contact us at any time – even after purchase. You can reach us directly at the mentioned addresses in the last chapter of these instructions.

Kindest Regards,

Your SCHUNK GmbH & Co. KG
Precision Workholding Systems
Bahnhofstr. 106 - 134
D-74348 Lauffen/ Neckar

Phone +49-7133-103-2503
Fax +49-7133-103-2189
automation@de.schunk.com
www.schunk.com

Document version: 16.12.2008



Table of contents

1. SAFETY	5
1.1. SYMBOL KEY.....	5
1.2. APPROPRIATE USE.....	5
1.3. GENERAL SAFETY.....	5
1.4. SAFETY NOTES.....	5
1.5. PROTECTION AGAINST DANGEROUS MOVEMENTS.....	6
1.6. AMBIENT AND OPERATING CONDITIONS.....	7
1.7. MODIFICATIONS TO THE LINEAR MOTOR DRIVE.....	7
1.8. OTHER RELEVANT DOCUMENTATION.....	7
2. WARRANTY	8
3. SCOPE OF DELIVERY	8
4. PRODUCT DESCRIPTION	9
4.1. OVERVIEW OF TYPES.....	9
4.2. FUNCTIONAL PRINCIPLE.....	12
5. TECHNICAL DATA	13
6. TRANSPORT AND STORAGE	14
6.1. TRANSPORT.....	14
6.2. STORAGE.....	14
7. COMMISSIONING	15
7.1. INSTALLATION PREPARATION.....	15
7.1.1. <i>Safety notes prior to use</i>	15
7.2. MAIN COMPONENTS.....	16
7.3. ASSEMBLY OF THE LINEAR MOTOR DRIVE.....	17
8. REPAIR	18
8.1. MODULE DESCRIPTION.....	18
8.2. CHANGING THE MOTOR HOUSING.....	19
8.2.1. <i>Uninstalling the motor housing</i>	20
8.2.2. <i>Installing the motor housing</i>	20
8.3. GUIDED SLIDE – CHANGING THE SUPPORT ROLLERS ON THE ECCENTRIC SIDE.....	21
8.3.1. <i>Uninstalling the support rollers</i>	21
8.3.2. <i>Installing the support rollers</i>	22
8.4. GUIDED SLIDE – CHANGING THE SUPPORT ROLLERS ON THE LOCATING BEARING SIDE.....	22
8.4.1. <i>Uninstalling the support rollers</i>	23
8.4.2. <i>Installing the support rollers</i>	23
8.5. CHANGING THE STROKE MEASURING SYSTEM.....	24
8.5.1. <i>Main components</i>	24
8.5.2. <i>Changing the measuring system LE 100</i>	25
8.5.3. <i>Changing the measuring system LS 100</i>	27
8.6. CHANGING THE RULER LE 100 / LS 100.....	29
8.7. CHANGING THE WIPERS.....	31
8.8. REPLACING THE BRAKE PISTON.....	32
8.8.1. <i>Uninstalling the brake piston</i>	33
8.8.2. <i>Installing the brake piston</i>	33
8.9. LIMIT SWITCHES AND REFERENCE SWITCHES.....	34
9. ELECTRICAL INTERFACES	35
9.1. MEASURING SYSTEMS.....	35
9.1.1. <i>Technical data</i>	35
9.1.2. <i>Interfaces of measuring system LE 100</i>	35
9.1.3. <i>Interfaces of measuring system LS 100</i>	36
9.2. HALL SENSORS.....	36
9.3. MOTOR.....	37



- 10. MAINTENANCE AND CARE38**
 - 10.1. PREVENTIVE MAINTENANCE BY THE CUSTOMER.....38
 - 10.1.1. *Weekly maintenance (depending on degree of contamination)*38
 - 10.1.2. *Every 2 to 4 weeks*38
- 11. ACCESSORIES39**
- 12. SPARE PARTS40**
 - 12.1. NOTE REGARDING SPARE PART ORDERS.....40
 - 12.2. NOTE REGARDING THE SPARE PARTS AND WEARING PARTS LIST40
 - 12.3. AXES.....41
 - 12.4. MOTORS.....42
 - 12.5. GUIDE45
 - 12.6. MEASURING SYSTEM46
 - 12.7. HOLDING BRAKE.....47
 - 12.8. ACCESSORIES48
- 13. EC DECLARATION OF INCORPORATION.....49**
- 14. CONTACT50**



1. Safety

1.1. Symbol key



This symbol is used whenever non-compliance may lead to dangers for persons.



This symbol is used whenever non-compliance may lead to damage to the product.



This symbol alerts you to important information concerning the product and its handling.

1.2. Appropriate use

Linear motor drives MLD type T are used exclusively for the purpose of transmitting linear movements using a directly driven drive module.



The axis is especially suited for applications for which very high dynamics are required.

1.3. General safety

- The objective of this operating manual is to provide qualified persons with the information necessary to enable them to carry out maintenance work on a linear motor drive MLD type T themselves.

1.4. Safety notes

1. Dangerous situations may arise in conjunction with the unit if, for example:
 - The linear motor drive is not used, installed or maintained properly.
 - The linear motor drive is used for purposes other than the intended appropriate use.
 - The EC Machinery Directive, the accident prevention regulations, the VDE directives, or the safety and installation notes are not observed.
2. The linear motor drive MLD type T may only be installed, commissioned and maintained by suitably trained specialist personnel based on these instructions.

3. The linear motor drive MLD type T is equipped with protective equipment for your safety. Nevertheless, danger may emanate from this drive if it is operated by insufficiently trained personnel or used for tasks that are not permitted.
4.  The secondary parts integrated in the linear motor drive MLD type T are high-performance permanent magnets. These can cause injuries to persons with implanted medical devices such as pacemakers or hearing aids, or implanted medical devices can cause malfunctions. Even when the linear motor drive is switched off, these persons must not stay close to the drive. Electronic modules, storage media, precision elements and other magnetically interactive objects can be damaged.
5. As a general rule, all work on the drives and control units may be performed only while they are shut down. There must not be any voltage present.
6.  If possible, avoid running measurement cables directly next to electric cables.
8. Before starting any assembly/disassembly or repair work, allow the linear motor drive to cool down.

1.5. Protection against dangerous movements

As a general rule, the linear motor drives may only be operated with additional safety devices which are not included in the scope of delivery. Dangerous movements can result when errors occur in controlling the drives. The drive components are monitored in a way that malfunctions can be largely excluded.

However, for reasons of personal safety, risk of injury and risk of property damage, you should not rely on this fact alone. Until the integrated safety features become effective, inaccurate drive movements must be expected.

Possible causes for control errors:

- Incorrect cabling or wiring
- Defective components
- Software errors
- Operating errors
- Removal of safety devices
- Sensor and signal transmitter errors
- Entry of incorrect parameters prior to start-up

1.6. Ambient and operating conditions

To ensure problem-free operation, certain ambient and operating conditions must be provided.

- (1) Ambient temperature: 10°C to 40°C
- (2) Permitted medium: Filtered compressed air (10 µm), dry, lubricated or non-lubricated
- (3) The drive must be protected against the following:
 - Exposure to direct sunlight or heat
 - Contamination due to chips, dust and other particles
 - Corrosive gases
 - Vibrations
 - Shock
 - Moisture
 - Oleaginous and acidic environments

If the components are to be used in adverse ambient conditions (e.g. honing oil or other corrosive media), consult with us.

1.7. Modifications to the linear motor drive

Modifications to the linear motor drive MLD type T and/or the attachment of third-party components can compromise the operational safety of the drive. This applies in particular to changes made to safety-relevant parts. If modifications are made to the linear motor drive, SCHUNK will not accept any warranty claims.

1.8. Other relevant documentation

Other relevant documentation with CD: Commissioning of Indradrive (German/English),
GAS order no. 315016



2. Warranty

The warranty period is 24 months from the delivery date to the production facility, provided the product is used as intended in one-shift operation and the prescribed maintenance and lubrication intervals have been observed. As a general rule, parts touching the workpiece and wearing parts are not part of the warranty. Also observe our general terms and conditions. They are available on our website at www.de.schunk.com in the “Service” section under “Terms of Sales and Delivery”.

3. Scope of delivery

The standard scope of delivery comprises: The ordered version of the linear motor drive MLD type T, including start-up CD and operating manual.



4. Product description

4.1. Overview of types

The linear motor drives are distinguished based on their type designation and size:

MLD 100T-1-345-640-4701-4701-.....4733(4)-0122

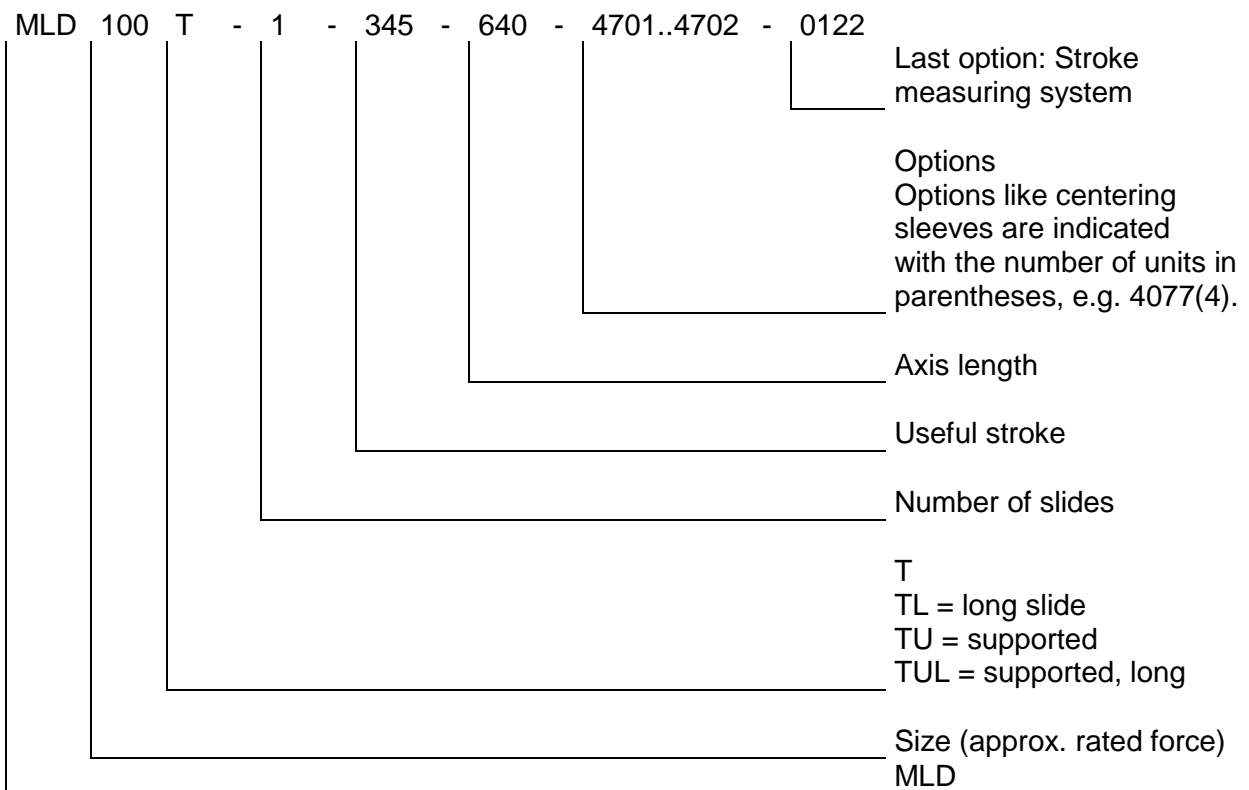

SCHUNK GmbH & Co.KG strives to constantly improve its products. Therefore it is important that you include the material number and serial number in all inquiries and spare part orders.

MLD 100 T, MLD 200 T, MLD 300 T

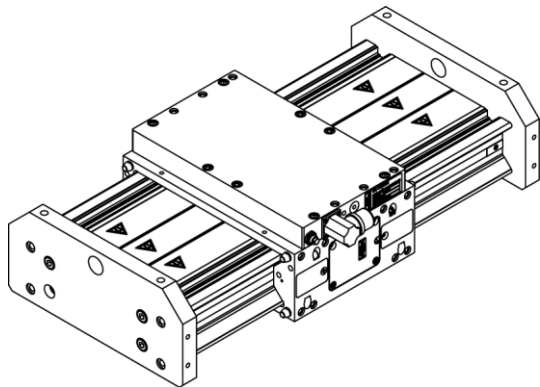

MLD 100 TU, MLD 200 TU, MLD 300 TU

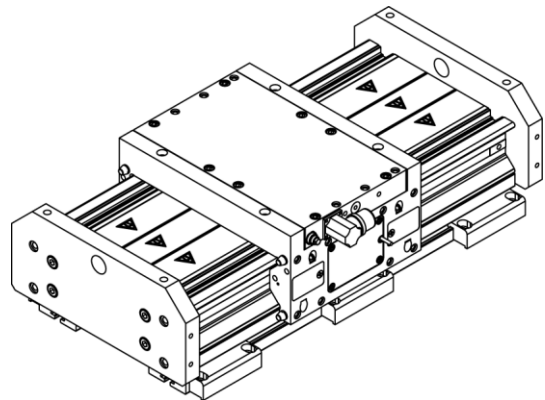

MLD 200 TL, MLD 400 TL, MLD 600 TL

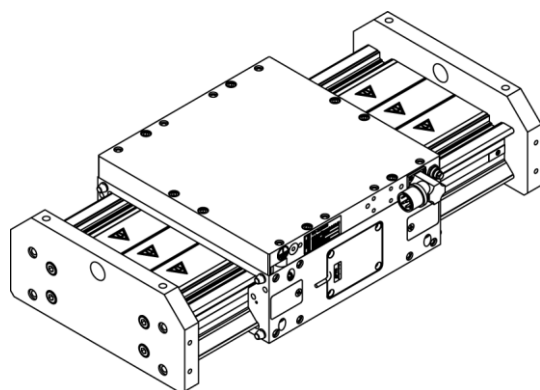

MLD 200 TUL, MLD 400 TUL, MLD 600 TUL

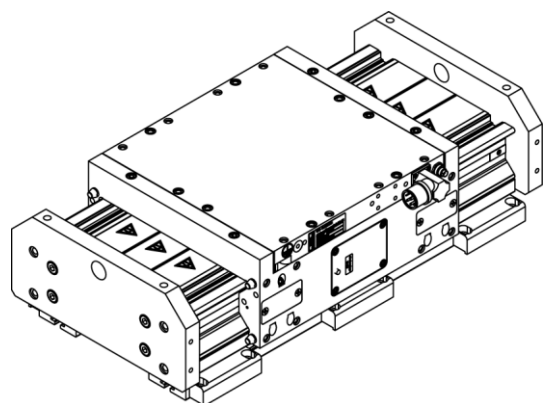

MLD 800 TL, MLD 1200 TL

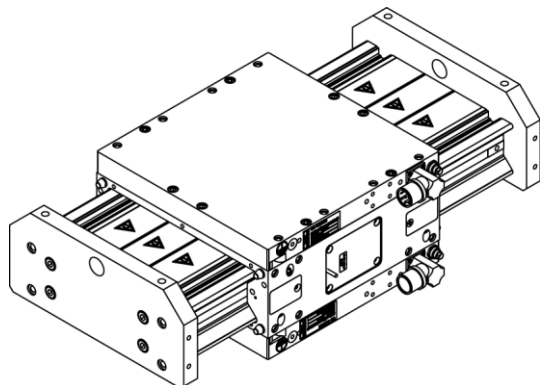

All versions of the linear motor drives MLD type T are available with multiple slides.

MLD 100 T-2 (second slide active)

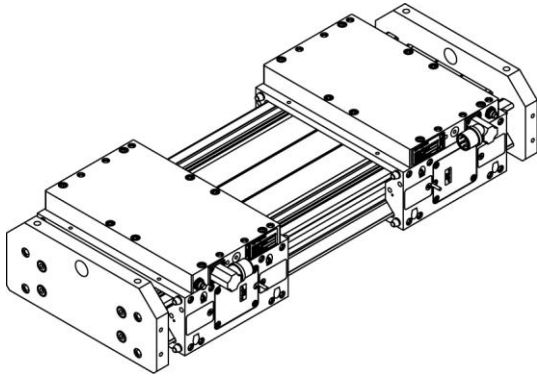

MLD 100 T-2 (second slide passive)

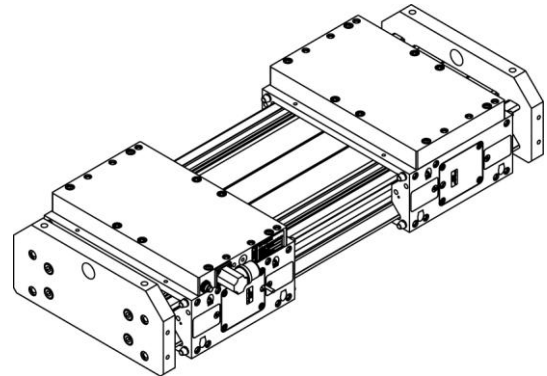

Figure 1: Linear motor drive MLD type T with 2 slides

4.2. Functional principle

The linear motor drive MLD type T is a directly driven drive module for linear movements. The driving force is transmitted directly to the slide without any mechanical transmission elements. The axis is especially suited for applications for which very high dynamics are required.

The overall concept of the linear motor drive is characterized by its extremely compact design. Thanks to the good guidance of the slide and the light-weight design of the axis, the drive reaches very high speeds, accelerations and repeat accuracies.

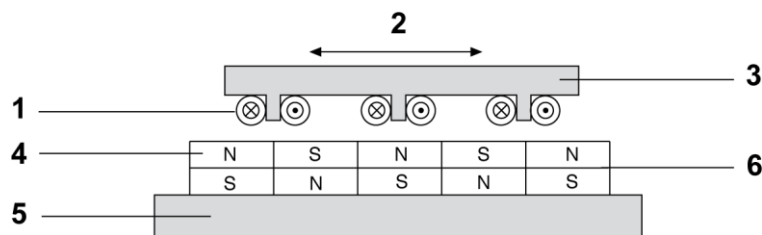

Figure 2: Functional principle of linear motor drive MLD type T

- (1) Copper coil
- (2) Directions of movement
- (3) Primary part
- (4) Permanent magnets
- (5) Iron mount
- (6) Secondary part

You can manipulate the driving force, acceleration and speed of the slide by regulating the phase and the amplitude of the electrical current applied at the primary part (item 3).

A magnetic measuring system, which is integrated in the axis, is used to determine the current position of the drive.

5. Technical data

Motor size		MLD 100 T	MLD 200 T	MLD 300 T	MLD 100 TU
Rated force ^{*2}	(N)	123	170	225	104
Maximum force ^{*1}	(N)	250	500	750	250
Repeat accuracy	(mm)	±0.01	±0.01	±0.01	±0.01
Max. continuous current at standstill	(A _{eff})	3.1	4.2	5.6	3.1
Maximum current	(A _{eff})	8.1	16.2	24.3	8.1
Coil resistance at 25°C	(Ohm)	7	3.7	2.1	7
Test voltage	(V)	2000	2000	2000	2000
Max. surface and ambient temperature	(°C)	70/40	70/40	70/40	70/40

Motor size		MLD 200 TU	MLD 300 TU	MLD 200 TL	MLD 400 TL
Rated force ^{*2}	(N)	143	189	208	288
Maximum force ^{*1}	(N)	500	750	500	1000
Repeat accuracy	(mm)	±0.01	±0.01	±0.01	±0.01
Max. continuous current at standstill	(A _{eff})	4.2	5.6	5.2	7.2
Maximum current	(A _{eff})	16.2	24.3	16.2	32.4
Coil resistance at 25°C	(Ohm)	3.7	2.1	3.5	1.9
Test voltage	(V)	2000	2000	2000	2000
Max. surface and ambient temperature	(°C)	70/40	70/40	70/40	70/40

Motor size		MLD 600 TL	MLD 200 TUL	MLD 400 TUL	MLD 600 TUL
Rated force ^{*2}	(N)	393	182	247	344
Maximum force ^{*1}	(N)	1500	500	1000	1500
Repeat accuracy	(mm)	±0.01	±0.01	±0.01	±0.01
Max. continuous current at standstill	(A _{eff})	9.8	5.2	7.2	9.8
Maximum current	(A _{eff})	48.6	16.2	32.4	48.6
Coil resistance at 25°C	(Ohm)	0.98	3.5	1.9	0.98
Test voltage	(V)	2000	2000	2000	2000
Max. surface and ambient temperature	(°C)	70/40	70/40	70/40	70/40

Motor size		MLD 800 TL	MLD 1200 TL
Rated force ^{*2}	(N)	800	784
Maximum force ^{*1}	(N)	2000	3000
Repeat accuracy	(mm)	±0.01	±0.01
Max. continuous current at standstill	(A _{eff})	14.4	19.6
Maximum current	(A _{eff})	64.8	97.2
Coil resistance at 25°C	(Ohm)	0.9	0.6
Test voltage	(V)	2000	2000
Max. surface and ambient temperature	(°C)	70/40	70/40

Table 1: Technical data of the linear motor drive

*¹) depending on control type

*²) depending on installation situation (heat dissipation)

Should you require additional technical data, please refer to our catalog. The respective latest version is valid (as stipulated in the General Terms and Conditions document, section 2.3).

6. Transport and storage

6.1. Transport

The linear motor drives MLD type T are precision drives. The packaging must protect the drive from all external effects (such as mechanical shocks and humidity).

6.2. Storage

Store the product in a clean, dry environment. Ambient temperature: 15–40°C.
No condensation permitted!

7. Commissioning

7.1. Installation preparation

7.1.1. Safety notes prior to use



Danger

Danger to life due to strong magnetic fields even in a shut-down state.

The secondary parts integrated in the linear motor drive MLD type T are high-performance permanent magnets. Medical devices, such as pacemakers or hearing aids, can be destroyed or can cause malfunctions.

- Observe an adequate minimum distance to the secondary part if you have a pacemaker or use a hearing aid or other devices.



Danger

Danger to life due to electric shock.

Touching live parts can be deadly.

- Work on electrical installations or equipment may only be carried out by electricians according to electrical standards.

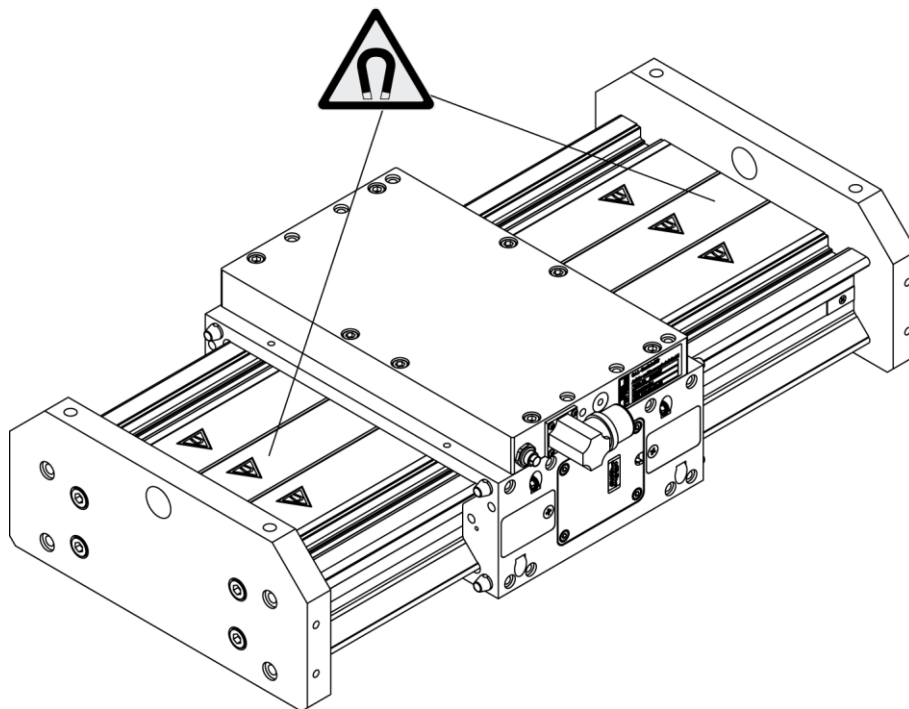

Figure 3: Magnetic area of linear motor drive MLD type T



During installation and commissioning, observe the technical data.

Notice For the technical data regarding

- Linear motor drive MLD type T
- Limit switches
- Reference switch
- Direct stroke measuring system

refer to the brochure: **Linear motor drive MLD type T**

7.2. Main components

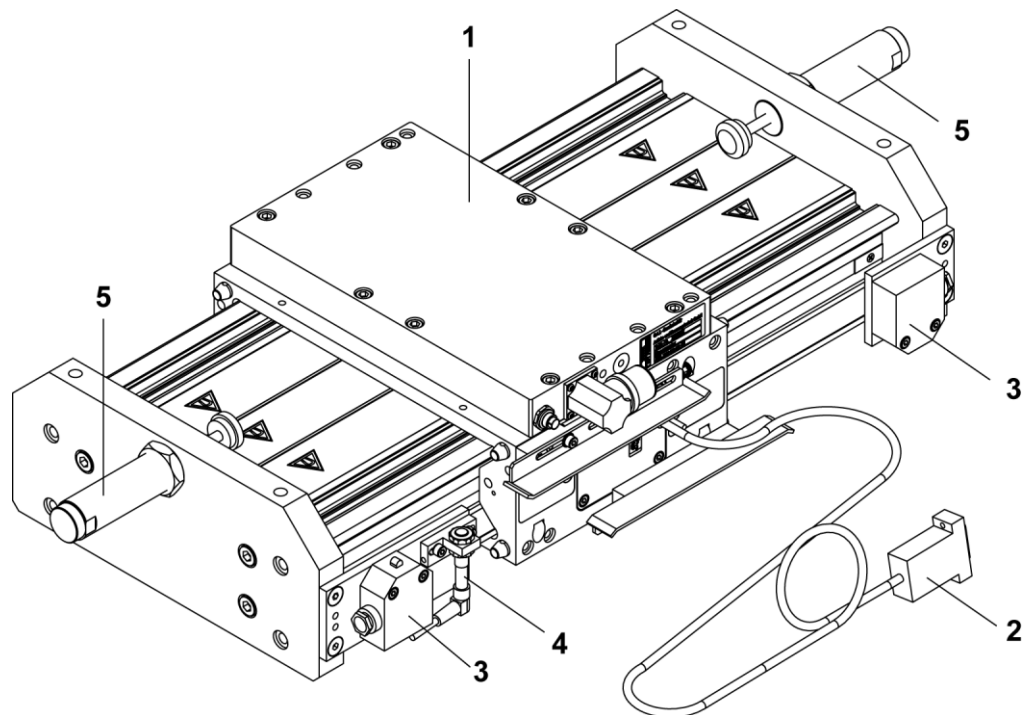

Figure 4: Main components of the linear motor drive MLD type T

- (1) Linear motor drive MLD 100 T
- (2) Direct stroke measuring system
- (3) Limit switches (optional)
- (4) Reference switch (optional)
- (5) Shock absorber (optional)

7.3. Assembly of the linear motor drive



Danger of crushing due to uncontrolled movements.

- Only carry out work on the linear motor drive while the machine is shut off.
- Make sure that neither electric nor pneumatic energy is present at the linear motor drive.

The linear motor drives have multiple mounting surfaces for additional linear axes; these are mounted using adapter plates.

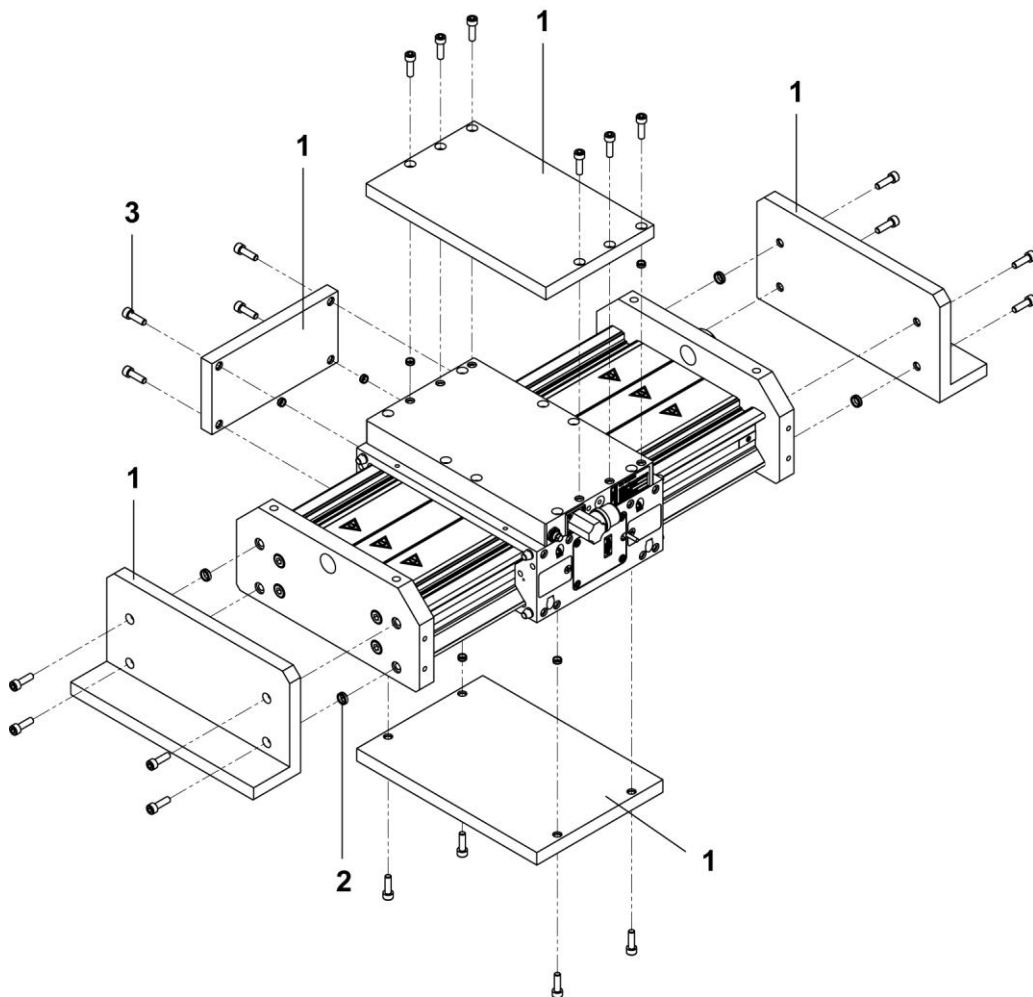

Figure 5: Mounting surfaces of the linear motor drive MLD type T

- (1) Adapter plate
- (2) Centering sleeve
- (3) Cylindrical screws

8. Repair

8.1. Module description

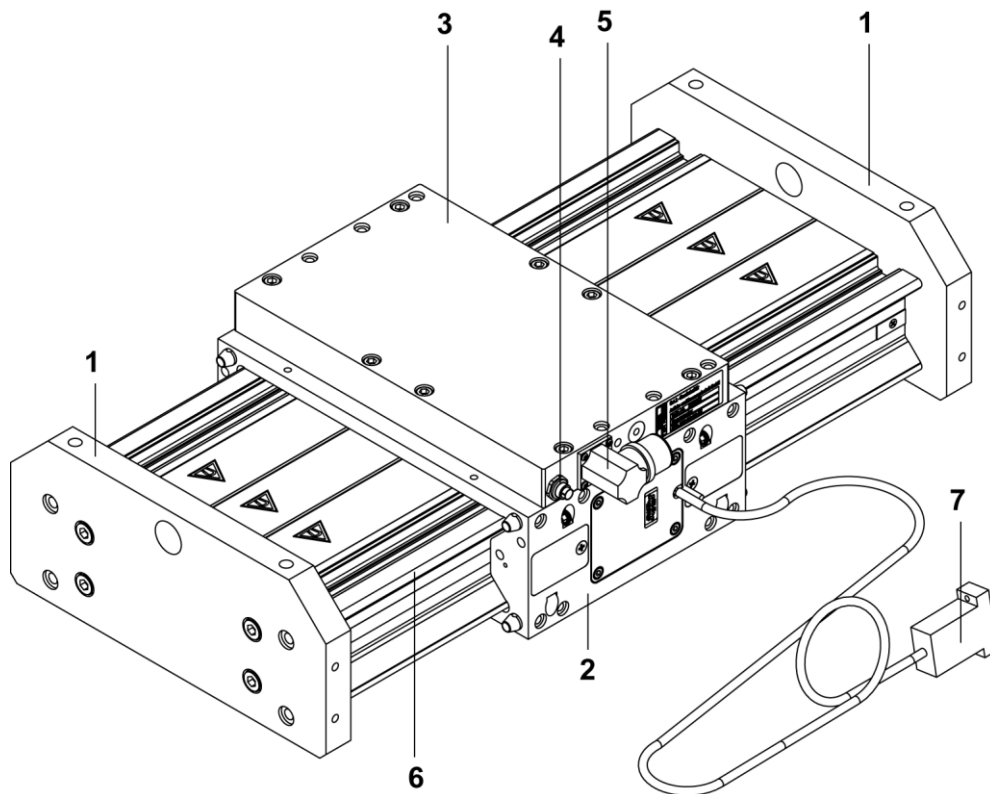

Figure 6: Module description of linear motor drive MLD type T

- (1) End plate
- (2) Guided slide
- (3) Motor housing
- (4) Hall sensor connector
- (5) Motor connector
- (6) Guide rail
- (7) Measuring system

8.2. Changing the motor housing



Notice

- During installation and commissioning, observe the technical data.
- As a general rule, all work on the drives and control units may be performed only while they are shut down. There must not be any electrical signals present.
- Allow the linear motor to cool down before starting any assembly or disassembly work.

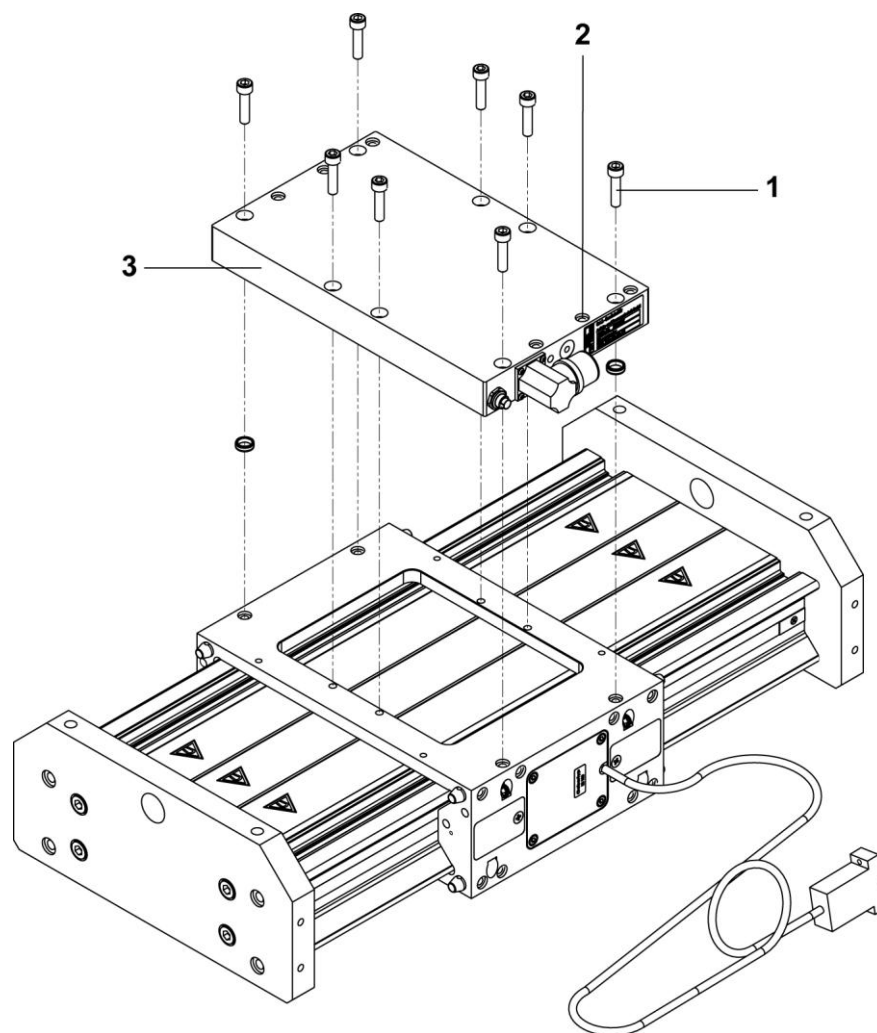

Figure 7: Changing the motor housing of a linear motor drive MLD type T

8.2.1. Uninstalling the motor housing

- Remove the screws (item 1).
- Using lifting screws M6x35 DIN 912 (item 2), lift the motor housing to bridge the magnetic force.
- Completely remove the motor housing (item 3).

8.2.2. Installing the motor housing

- Install the lifting screws (item 2).
(Let them protrude 5 mm.)
- Place the motor housing (item 3) on the guide rail.
- Slowly unscrew the lifting screws (item 2) one by one and set the motor housing onto the guided slide (item 4).
- Install the screws (item 1) (8x).



Never install the motor without lifting screws.
Danger of crushing!

8.3. Guided slide – changing the support rollers on the eccentric side

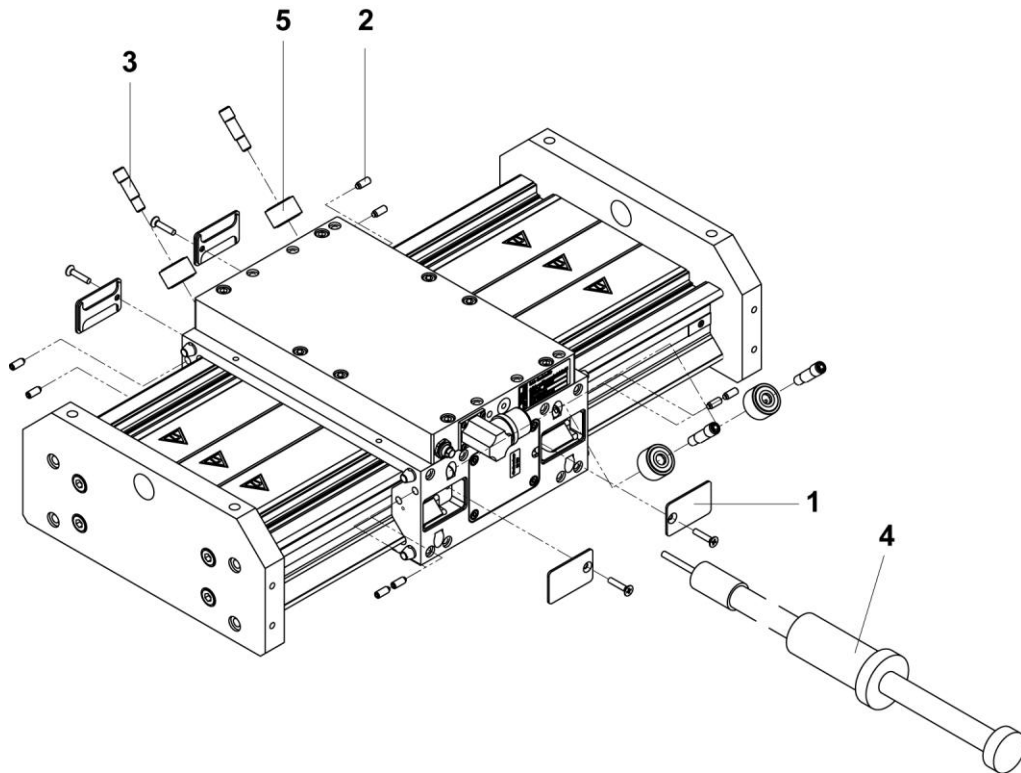

Figure 8: Support roller change on eccentric side

8.3.1. Uninstalling the support rollers

- Remove the roller cover (item 1) (2x).
- Unscrew the pressure pins (item 2) (8x).
- Pull out the eccentric shaft (item 3) using the extracting tool (item 4) (4x).
- Remove the support rollers (item 5) (4x).

8.3.2. Installing the support rollers

- Insert the support rollers (item 5) (4x).
- With a rotary motion, fit the eccentric shaft (item 3) into place (4x).
- Turn the eccentric shaft (item 3) using a hexagon socket wrench until you can no longer turn the support roller (item 5) by hand.
- Firmly screw in pressure pins (item 2) (8x).
- Install the roller cover (item 1) (2x).

8.4. Guided slide – changing the support rollers on the locating bearing side

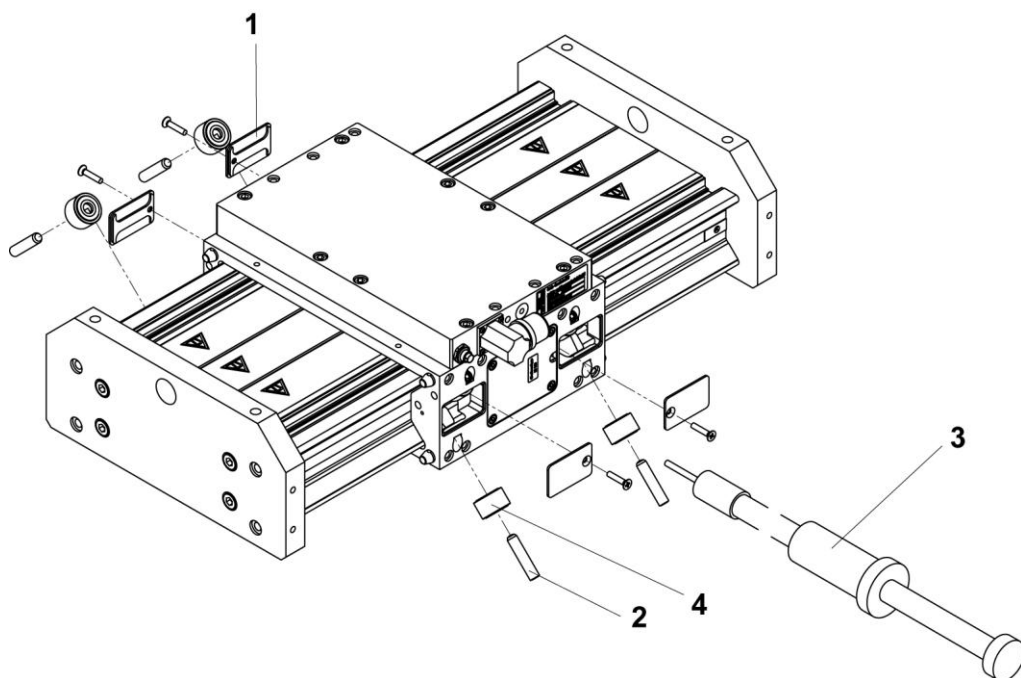

Figure 9: Support roller change on locating bearing side

8.4.1. Uninstalling the support rollers

- Remove the roller cover (item 1).
- Pull out the support roller bearing (item 2) using the extracting tool (item 3) (4x).
- Remove the support rollers (item 4) (4x).

8.4.2. Installing the support rollers

- Insert the support rollers (item 4) (4x).
- Insert the support roller bearing (item 2) (4x).
- Adjust the guided slide using the eccentric shafts, see chapter Changing the support rollers on the eccentric side.
- Install the roller cover (item 1).

8.5. Changing the stroke measuring system



Due to the adjustment work required, the stroke measuring system should only be changed by specialist personnel.

Notice

8.5.1. Main components

Different measuring systems are used in the drives. This documentation describes two different measuring systems.

1. LE 100
2. LS 100

For more information on the optical and absolute stroke measuring systems, refer to the corresponding operating manuals.

The measuring systems LE 100 and LS 100 are non-contact incremental measuring systems. In connection with the measuring tape in the Schunk axes, the sensor head supplies a periodically recurring signal.

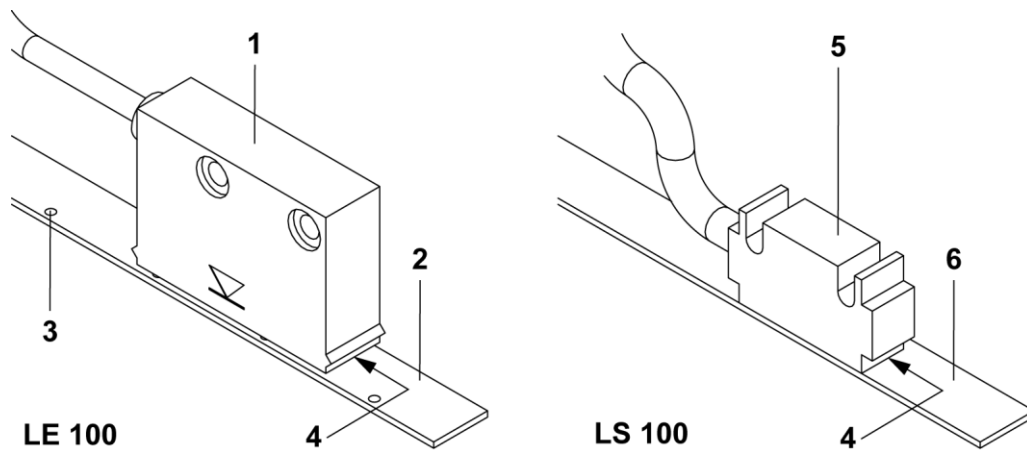

Figure 10: Measuring system modules

- (1) Reading head LE 100
- (2) Magnetic strip LE 100
- (3) Marking on magnetic strip
- (4) Distance between reading head and magnetic strip
- (5) Reading head LS 100
- (6) Magnetic strip LS 100

8.5.2. Changing the measuring system LE 100

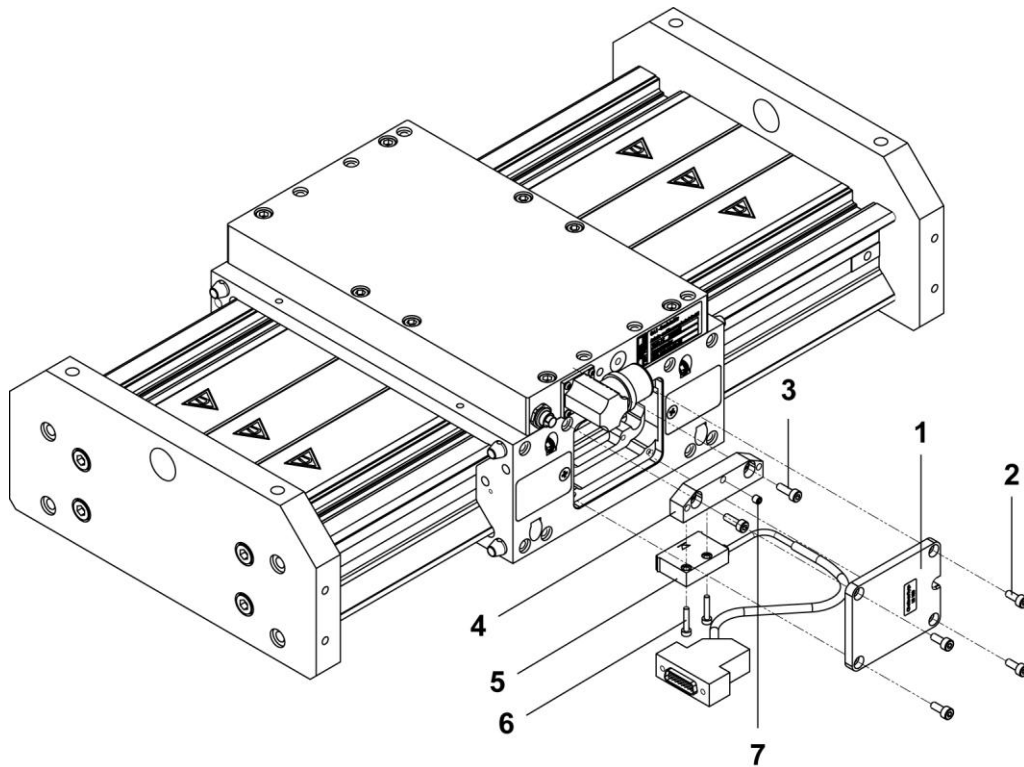

Figure 11: Measuring system LE 100

- (1) Cover
- (2) Cylindrical screws
- (3) Cylindrical screws
- (4) Reading head support
- (5) Reading head LE 100
- (6) Cylindrical screws
- (7) Set screw



The measuring system is precisely adjusted. In the event of a disassembly, the measuring system must be re-adjusted. Memorize the installation position of the reading head support. The cable must point in the same direction again.

- Remove the cover (item 1).
- Uninstall the reading head support (item 4).
- Remove the reading head (item 5) and replace it.



Special tool

**Tester for measuring system LD including adapter cable
(GAS order no. 323712).**

Note

- Screw the reading head (item 5) to the reading head support (item 2).
- Screw the reading head support (item 4) into the recess on the slide. Ensure parallel position.
- The set and fastening screws on the reading head support with reading head have the following meaning:
- Use the measuring system tester to test the electric output signal of the reading head.
- Based on the result, you can calculate the distance between the ruler and the reading head. It must be 0.2 ± 0.05 mm along the entire length.
- If necessary, use the set screw (item 7) to adjust the height.
- When the height is adjusted correctly, set the height adjustment using the screws (item 3).



Notice

When installing the reading head support complete with reading head, ensure the correct installation position. The markings on the reading head (1) and the ruler (2) must be on the same side.

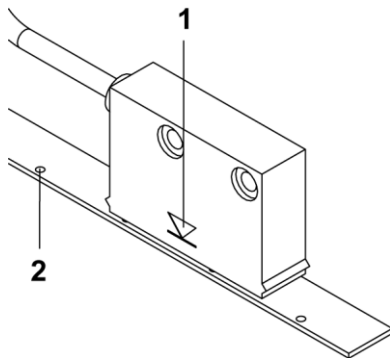

Figure 12: Markings on reading head and ruler LE 100



Notice

Because Schunk offers other stroke measuring systems in addition to the stroke measuring system described here, you must also observe the corresponding separate documentation.

8.5.3. Changing the measuring system LS 100

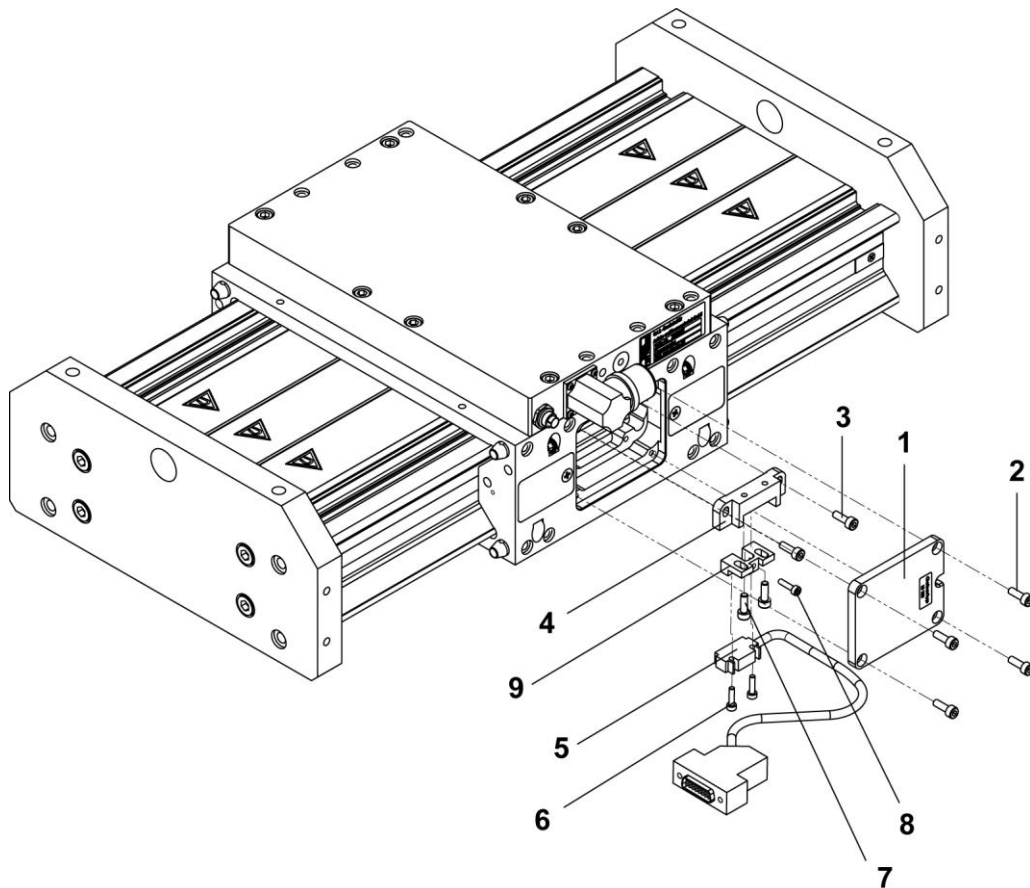

Figure 13: Measuring system LS 100

- (1) Cover
- (2) Cylindrical screws
- (3) Cylindrical screws
- (4) Reading head support
- (5) Reading head LS 100
- (6) Cylindrical screws
- (7) Set screw
- (8) Cylindrical screw
- (9) Reading head retainer



The measuring system is precisely adjusted. In the event of a disassembly, the measuring system must be re-adjusted. Memorize the installation position of the reading head support. The cable must point in the same direction again.

- Remove the cover (item 1).
- Uninstall the complete reading head support assembly (item 4).
- Remove the reading head (item 5) and replace it.



Special tool

**Tester for measuring system LD including adapter cable
(GAS order no. 323712).**

Note

- Screw the reading head (item 5) to the reading head support assembly (item 2).
- Screw the reading head support (item 4) into the recess on the slide. Ensure parallel position.
- The set and fastening screws on the reading head support with reading head have the following meaning:
- Use the measuring system tester to test the electric output signal of the reading head.
- Based on the result, you can calculate the distance between the ruler and the reading head. It must be 0.2 ± 0.05 mm along the entire length.
- If necessary, use the set screw (item 7) to adjust the height.
- When the height is adjusted correctly, set the height adjustment using the screws (item 3).



Notice

When installing the reading head support complete with reading head, ensure the correct installation position.



Notice

Because Schunk offers other stroke measuring systems in addition to the stroke measuring system described here, you must also observe the corresponding separate documentation.

8.6. Changing the ruler LE 100 / LS 100

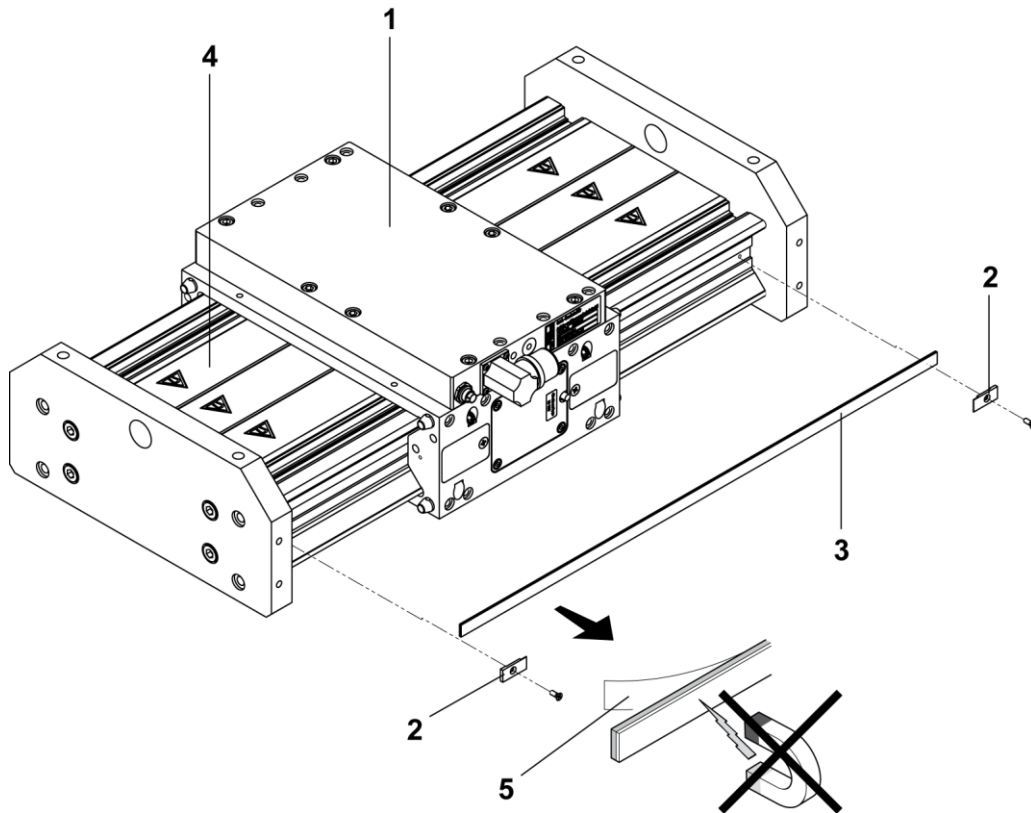

Figure 14: Changing the ruler LE 100 / LS 100

- (1) Guided slide
- (2) Ruler clamping
- (3) Ruler
- (4) Guide rail
- (5) Protective film



The magnetic strip of the measuring system must not be exposed to a strong magnetic field. At about 30 gauss or more, the magnetic strip encoding will be destroyed. Keep it away from the secondary part (permanent magnets) of the linear motor drive.

- Move the guided slide (item 1) to one side.
- Unscrew the ruler clamping (item 2) (2x).
- Carefully detach the ruler (item 3) from the guide rail (item 4) using a knife point and pull it off.

- Carefully clean the guide rail (item 4) of all adhesive residue using petroleum ether.
- Slide the ruler (item 3) underneath the guided slide (item 1) and place it on the guide rail (item 4).
- Length of the ruler (item 3) = length of the guide rail (item 4), i.e. 38 mm.
- Lift up one side of the ruler (item 3) slightly and, using forceps, remove the protective film (item 5) from the adhesive film.
- While pulling off the protective film, press the ruler (item 3) onto the guide rail (item 4).
- When you are half-way done, slide the guided slide (item 1) to the opposite side.
- Fasten the ruler clamping (item 2) (2x).

8.7. Changing the wipers



Notice

When using wipers, it is especially important that you clean the guide strips and lubricate them with an oil-soaked cloth.

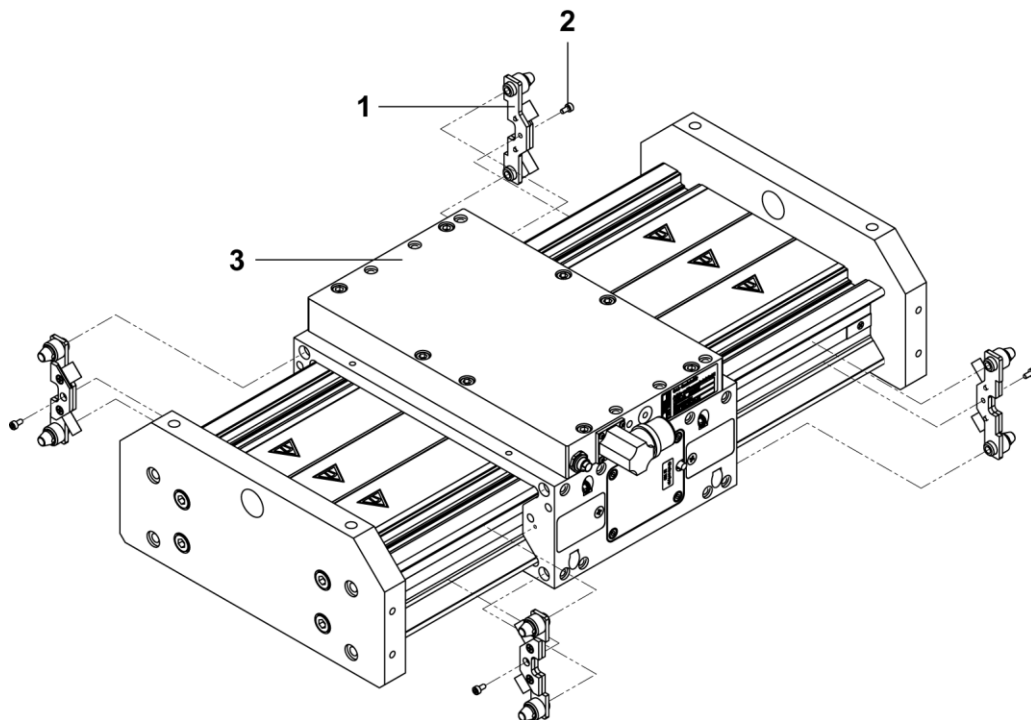

Figure 15: Changing the wipers

- (1) Wipers
- (2) Fastening screw
- (3) Guided slide

- Slide the guided slide (item 3) to the center of the axis.
- Unscrew the fastening screw (item 2).
- Change the wiper (item 1).
- Tighten the fastening screw (item 2).

8.8. Replacing the brake piston



Switch off controller and compressed air.
The brake piston is pre-loaded with disk springs.

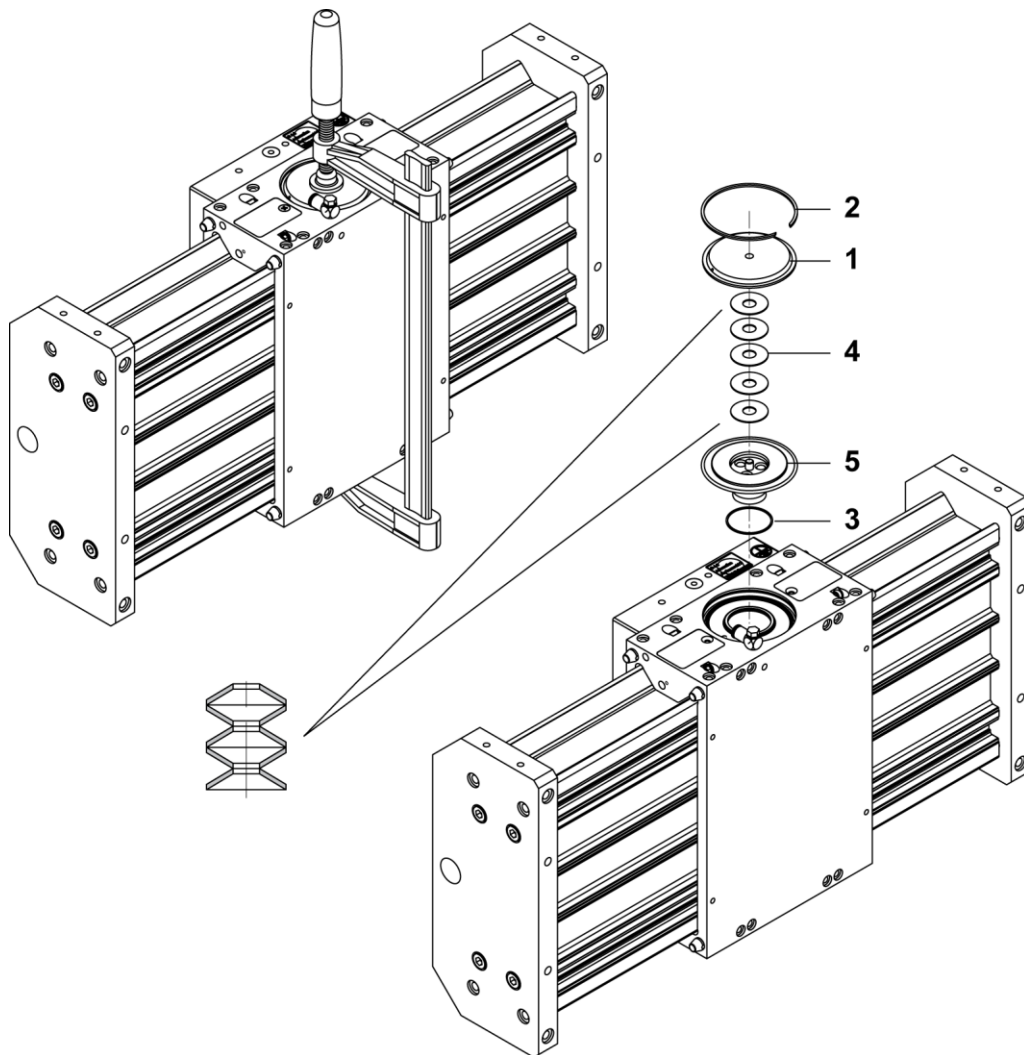

Figure 16: Replacing the brake piston

- (1) Brake cover
- (2) Retaining ring
- (3) O-ring
- (4) Disk springs
- (5) Brake piston

8.8.1. Uninstalling the brake piston

- Using a vise, clamp the brake cover (item 1).
- Remove the retaining ring (item 2).
- Slowly loosen the vise.
- Remove the brake cover (item 1), O-ring (item 3) and disk springs (item 4).
- Using pliers (with braces), pull out the brake piston (item 5).

8.8.2. Installing the brake piston

- Slightly grease and insert the O-ring (item 3).
- Insert the brake piston (item 5) and fit the membrane into place.
- Fit the disk springs (item 4) and the brake cover (item 1).



When installing the disk springs (item 4), make sure the individual disk springs are placed in the correct position.

Notice

- Set the vise onto the brake cover (item 1) and press in the cover.
- Install the retaining ring (item 2).
- Loosen and remove the vise.

8.9. Limit switches and reference switches

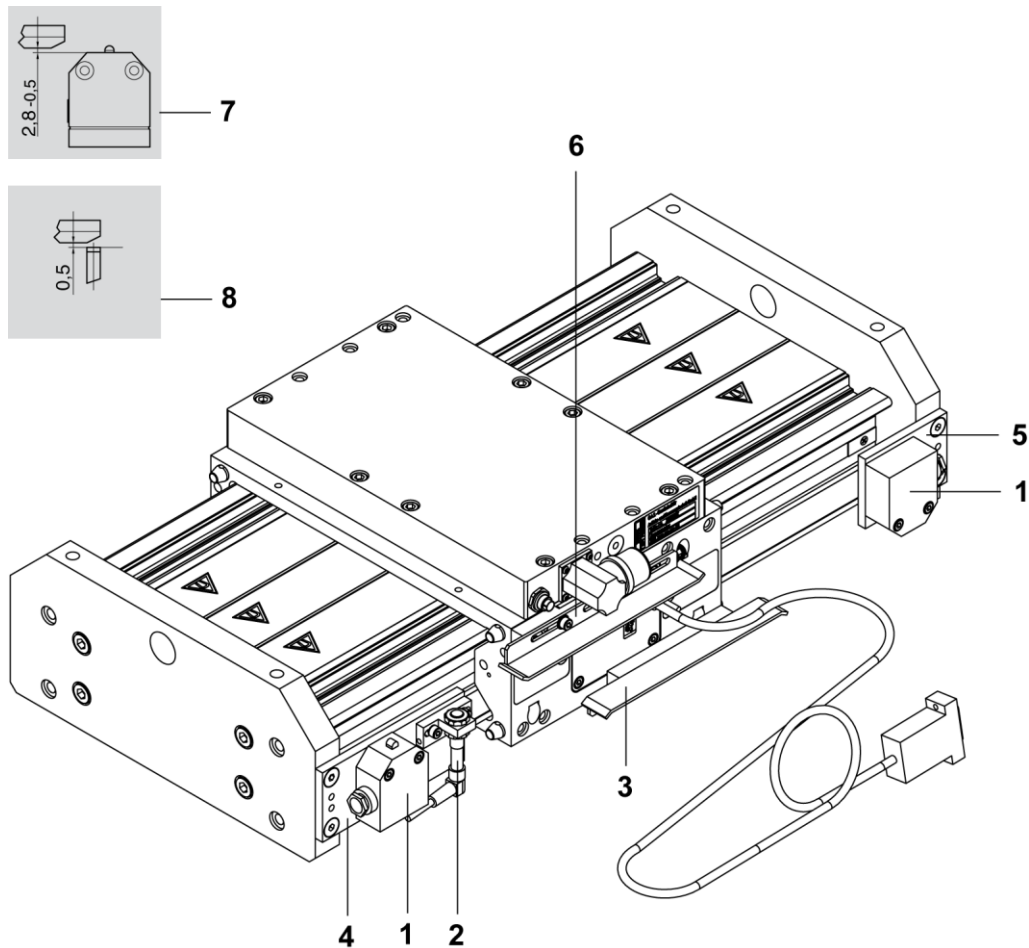

Figure 17: Mechanical limit switches and inductive reference switch

- (1) Limit switches, mechanical
- (2) Reference switch, inductive
- (3) Switching lug
- (4) Limit and reference switch baseplate
- (5) Limit switch baseplate
- (6) Distance plate
- (7) Switching distance, mechanical limit switch
- (8) Switching distance, inductive reference switch

9. Electrical interfaces

9.1. Measuring systems

9.1.1. Technical data

Description		LE 100	LS 100
Operating voltage	(VDC)	5 ± 5%	5 ± 5%
Output signal		Sin, Cos, Sin, Cos	Sin, Cos, Sin, Cos
Signal amplitude	(Vss)	1 ±10%	1 ±10%
Offset sine/cosine	(V)	2.5 ±0.5%	2.5 ±0.5%
Signal period	(µm)	1000	1000
Reference signal, periodic	(mm)	20	1*
Distance reading head – measuring tape (incl. covering tape)	(mm)	0.2 ±0.05	0.2 ±0.05

*) With reference converter

9.1.2. Interfaces of measuring system LE 100

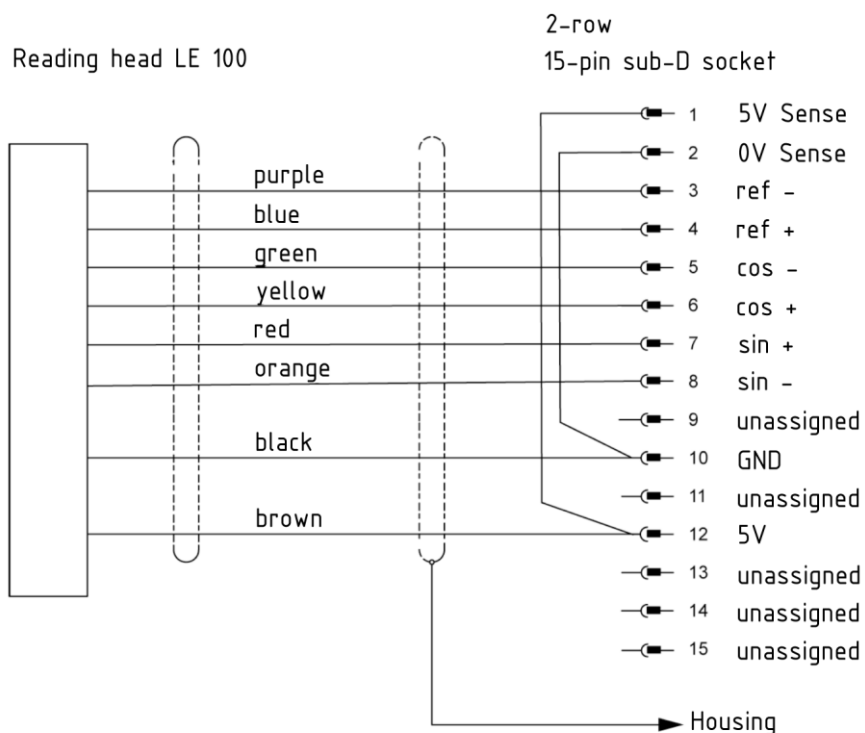

9.1.3. Interfaces of measuring system LS 100

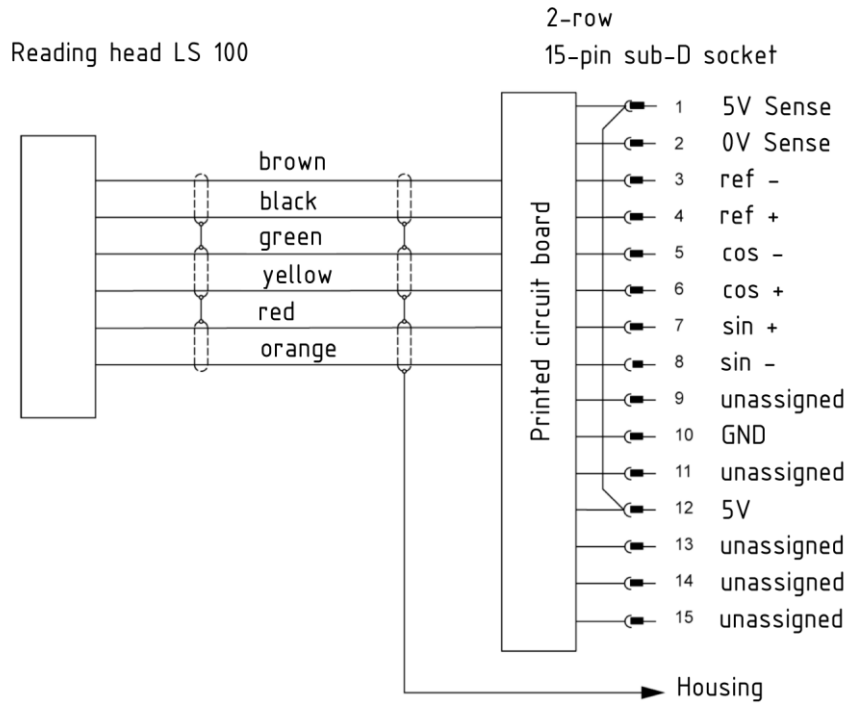

9.2. Hall sensors

8-pin socket
Series 712

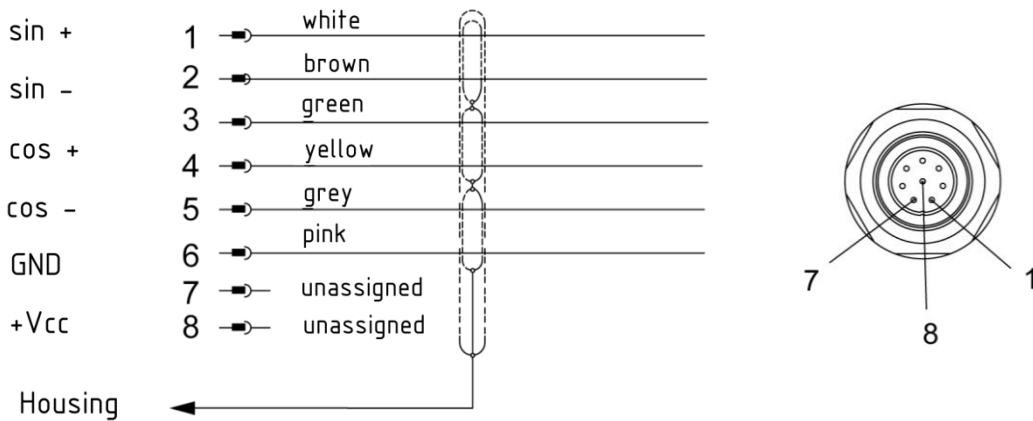

9.3. Motor

Type 1: Hypertac

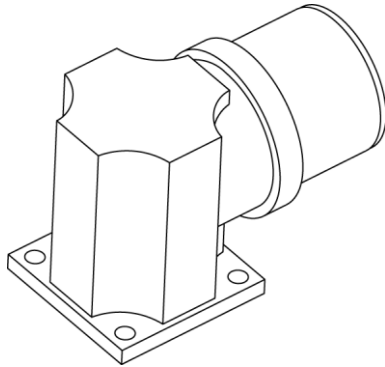

Type 3: Interconnect

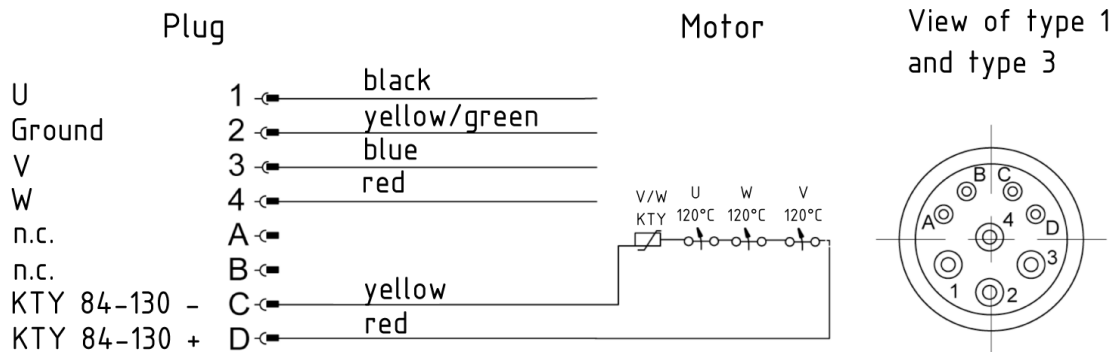
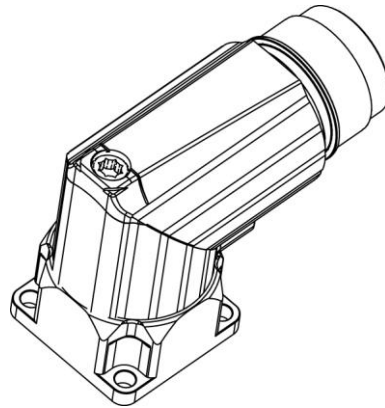

10. Maintenance and care



Only carry out work on linear motor drives while the machine is switched off.

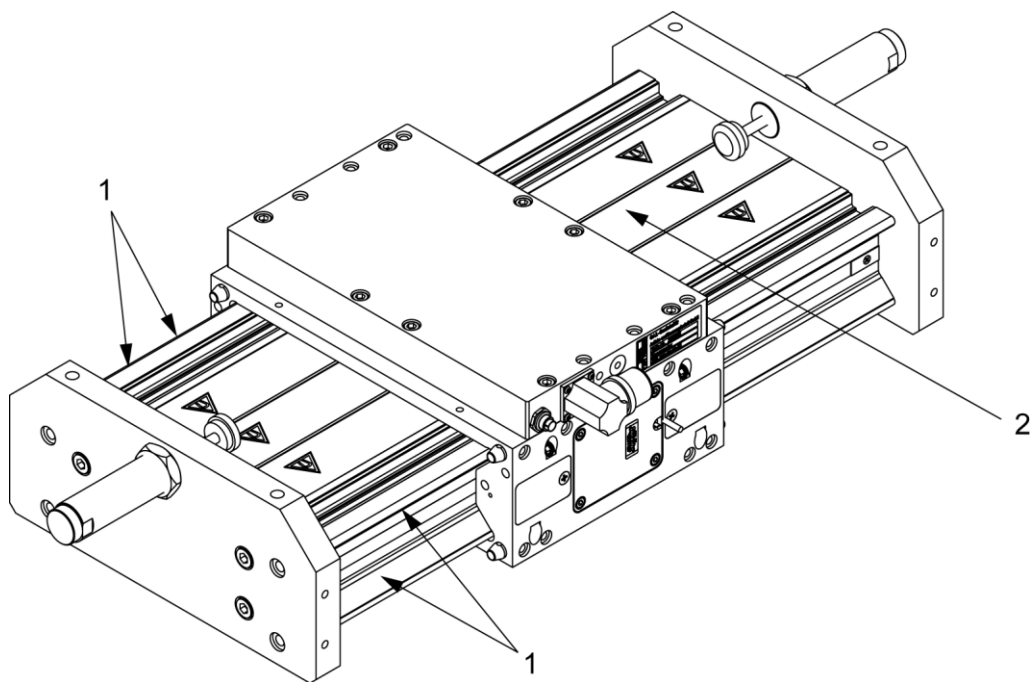

Figure 18: Maintenance of guide and secondary part

10.1. Preventive maintenance by the customer

To ensure the operational safety of the linear motor drive MLD type T over a long period of time, the operating personnel must carry out maintenance work in specific intervals.

10.1.1. Weekly maintenance (depending on degree of contamination)

- Rub the guide strips (item 1) with an oil-soaked cloth.

10.1.2. Every 2 to 4 weeks

- Clean the secondary part (item 2) with ethyl alcohol.



11. Accessories

Accessories from Schunk – the ideal components for the best functionality, reliability, and controlled production for all automation modules.

1	Centering sleeves	For precisely fitting connections between axes and
2	Inductive sensors	For end position control and reference measurement
3	Mechanical limit switches	For end position control
4	Connection cable for reference and limit switches	All required connection cables
5	Shock absorber	For supporting the masses in case of system failures
6	Wipers	For wiping the tracks during operation
7	Cable tracks	Safe energy supply with moving actuators
8	Holding brake	Pneumatic standstill brake for controller relief and for vertical applications
9	Pneumatic switching valve	For controlling the holding brake
10	Cable sets	Various cable sets and cable lengths for different controller types and distances
11	Commissioning tools	Start-up software, programming cable and commissioning instructions for controllers
12	Drive controllers and control units	Proven and approved components for your application scenario

For more detailed information, refer to the main catalog.

12. Spare parts

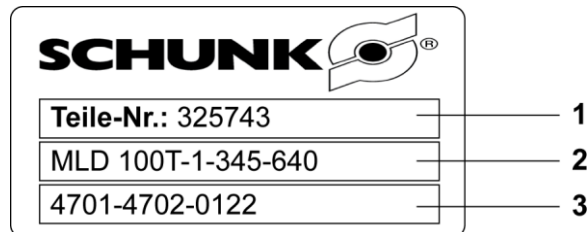

Figure 19: Nameplate

12.1. Note regarding spare part orders

Our products are always subject to technical modification and improvement. To avoid incorrect deliveries, and to order parts without a part number, always provide the information specified on the nameplate as well as the serial number of the linear motor drive.

The nameplate (Figure 19) is located on the guide rail.

Example:

- (1) Part no. – item number
- (2) Axis designation MLD 100 T with number of slides – useful stroke – profile length
- (3) Options

12.2. Note regarding the spare parts and wearing parts list

Remark:

- S Only with optional switch
- H Stroke-dependent
- R Cleaning agent
- E End position dampening

12.3. Axes

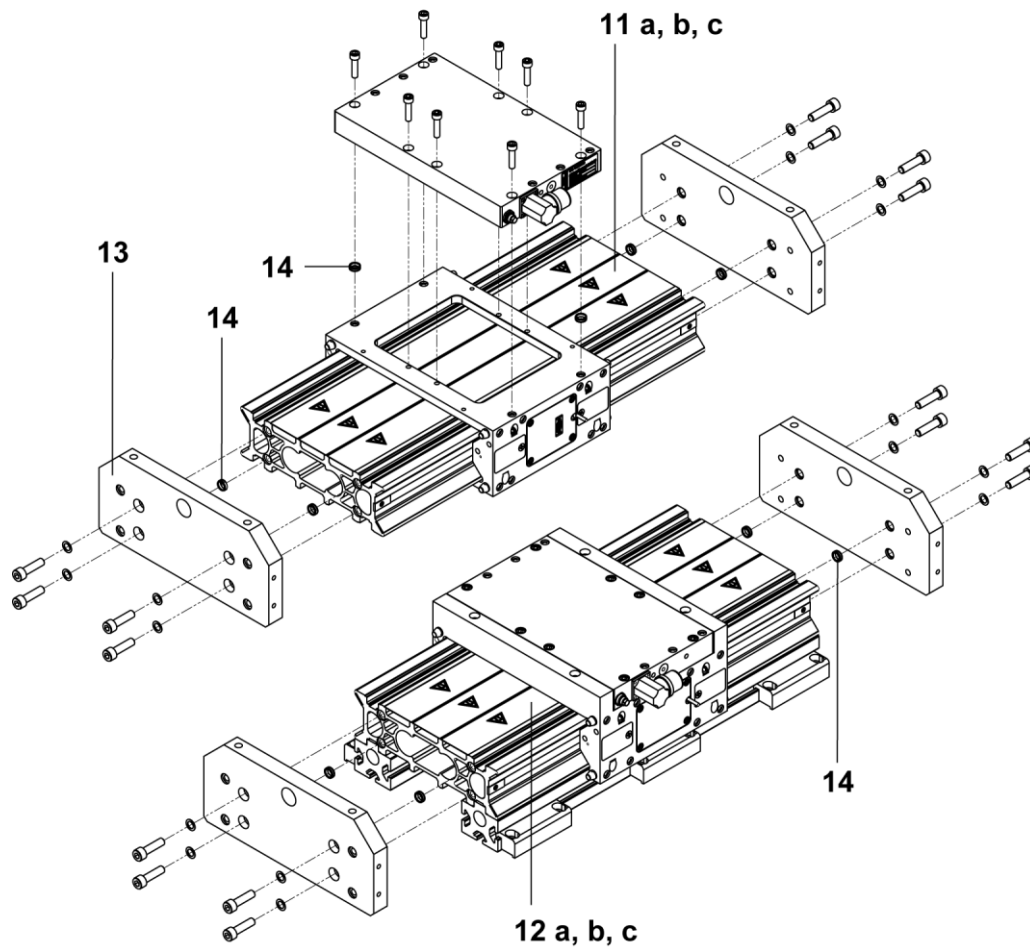

Figure 20: Spare parts – axis

Item	Type of axis	Designation	Quantity	Option	GAS order no.
11a	T(L)	Profile guide 1, secondary part	1	H	359 928
11b	T(L)	Profile guide 2, secondary part	1	H	350 918
11c	T(L)	Profile guide 3, secondary part	1	H	350 917
12a	TU(L)	Profile guide 1, secondary part	1	H	350 915
12b	TU(L)	Profile guide 2, secondary part	1	H	350 912
12c	TU(L)	Profile guide 3, secondary part	1	H	350 913
13	TL	End plate	1		332 806
14	All	Centering sleeve Ø 12	6		300 441
15	All	Ethyl alcohol 50 ccm	1	R	301 480
16	All	Oil 50 ccm	1	R	301 478
17	All	Measuring system tester	1		323 712
18	All	Documentation Commissioning of Indradrive (German/English) including CD-ROM	1		315 016

12.4. Motors

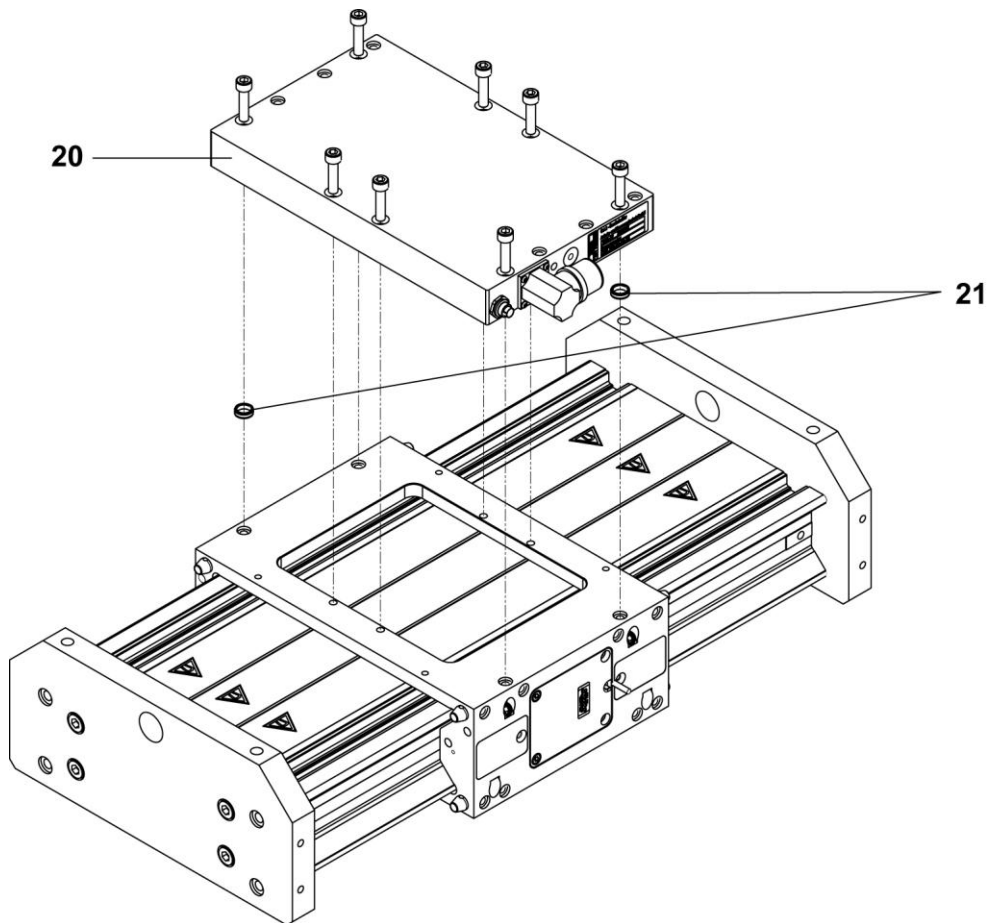
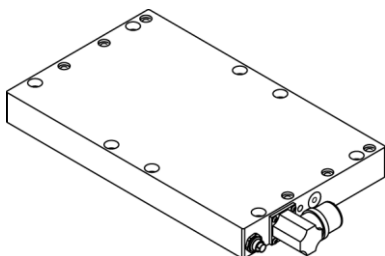

Figure 21: Spare parts – motors

Motor variants MLD type T(U)

Variant 1: Linear motor RS



Variant 2: Linear motor LS

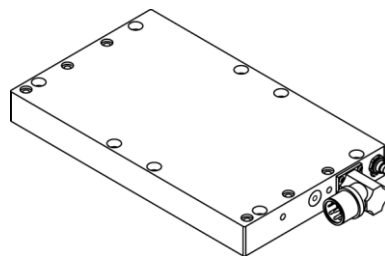

Motor variants MLD type T(U)L

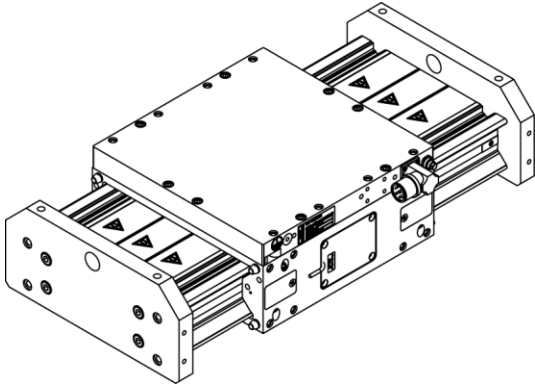

Variant 3: Linear motor RS

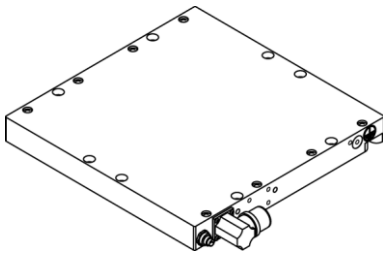

Variant 4: Linear motor LS

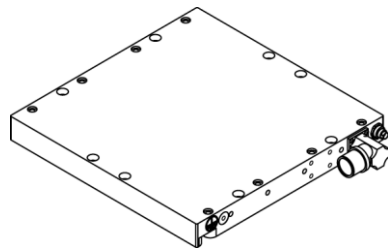

Motor variants MLD type T (double motors): MLD 800 TL, MLD 1200 TL

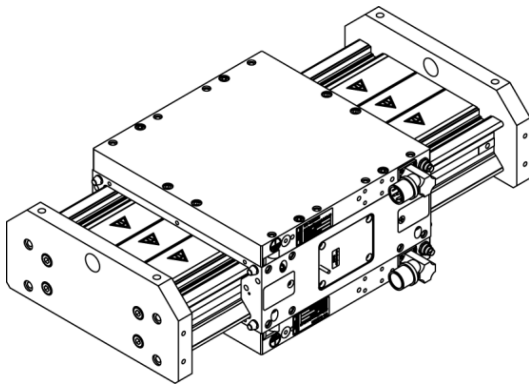

**Variant 5:
Linear motor MLD 800, 1200 TL**

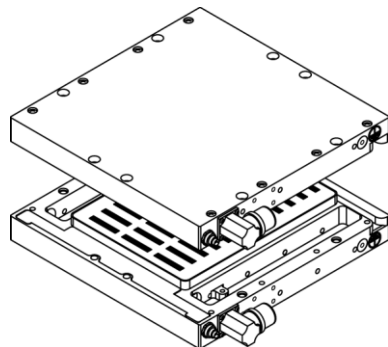

Motors without Hall sensor

Item	Type of axis	Designation	Quantity	Variant	GAS order no.	
20	MLD 100 T(U)	Linear motor MLS 10-250-15 LS	1	2	352 558	
	MLD 100 T(U)	Linear motor MLS 10-250-15 RS	1	1	352 559	
	MLD 200 T(U)	Linear motor MLS 20-250-15 LS	1	2	352 560	
	MLD 200 T(U)	Linear motor MLS 20-250-15 RS	1	1	352 561	
	MLD 300 T(U)	Linear motor MLS 30-250-15 LS	1	2	352 562	
	MLD 300 T(U)	Linear motor MLS 30-250-15 RS	1	1	352 563	
	MLD 200 T(U)L	Linear motor MLS 20-250-25 LS	1	4	352 567	
	MLD 200 T(U)L	Linear motor MLS 20-250-25 RS	1	3	352 568	
	MLD 400 T(U)L	Linear motor MLS 40-250-25 LS	1	4	352 569	
	MLD 400 T(U)L	Linear motor MLS 40-250-25 RS	1	3	352 570	
	MLD 600 T(U)L	Linear motor MLS 60-250-25 LS	1	4	352 571	
	MLD 600 T(U)L	Linear motor MLS 60-250-25 RS	1	3	352 572	
	MLD 800 TL		Linear motor MLD 80-250-25 LS	1	5	352 615
			Linear motor MLD 80-250-25 RS	1		352 616
MLD 1200 TL		Linear motor MLD 120-250-25 LS	1	5	352 493	
		Linear motor MLD 120-250-25 RS	1		352 494	
21	All	Centering sleeve Ø 9	6		301 587	

Motors with Hall sensor

Item	Type of axis	Designation	Quantity	Variant	GAS order no.	
20	MLD 100 T(U)	Linear motor MLS 10-250-15 LS	1	2	336 147	
	MLD 100 T(U)	Linear motor MLS 10-250-15 RS	1	1	336 146	
	MLD 200 T(U)	Linear motor MLS 20-250-15 LS	1	2	333 872	
	MLD 200 T(U)	Linear motor MLS 20-250-15 RS	1	1	333 870	
	MLD 300 T(U)	Linear motor MLS 30-250-15 LS	1	2	330 249	
	MLD 300 T(U)	Linear motor MLS 30-250-15 RS	1	1	330 251	
	MLD 200 T(U)L	Linear motor MLS 20-250-25 LS	1	4	333 626	
	MLD 200 T(U)L	Linear motor MLS 20-250-25 RS	1	3	333 625	
	MLD 400 T(U)L	Linear motor MLS 40-250-25 LS	1	4	333 876	
	MLD 400 T(U)L	Linear motor MLS 40-250-25 RS	1	3	333 874	
	MLD 600 T(U)L	Linear motor MLS 60-250-25 LS	1	4	330 149	
	MLD 600 T(U)L	Linear motor MLS 60-250-25 RS	1	3	330 150	
	MLD 800 TL		Linear motor MLD 80-250-25 LS	1	5	333 876
			Linear motor MLD 80-250-25 RS	1		333 874
MLD 1200 TL		Linear motor MLD 120-250-25 LS	1	5	330 149	
		Linear motor MLD 120-250-25 RS	1		330 150	
21	All	Centering sleeve Ø 9	6		301 587	

12.5. Guide

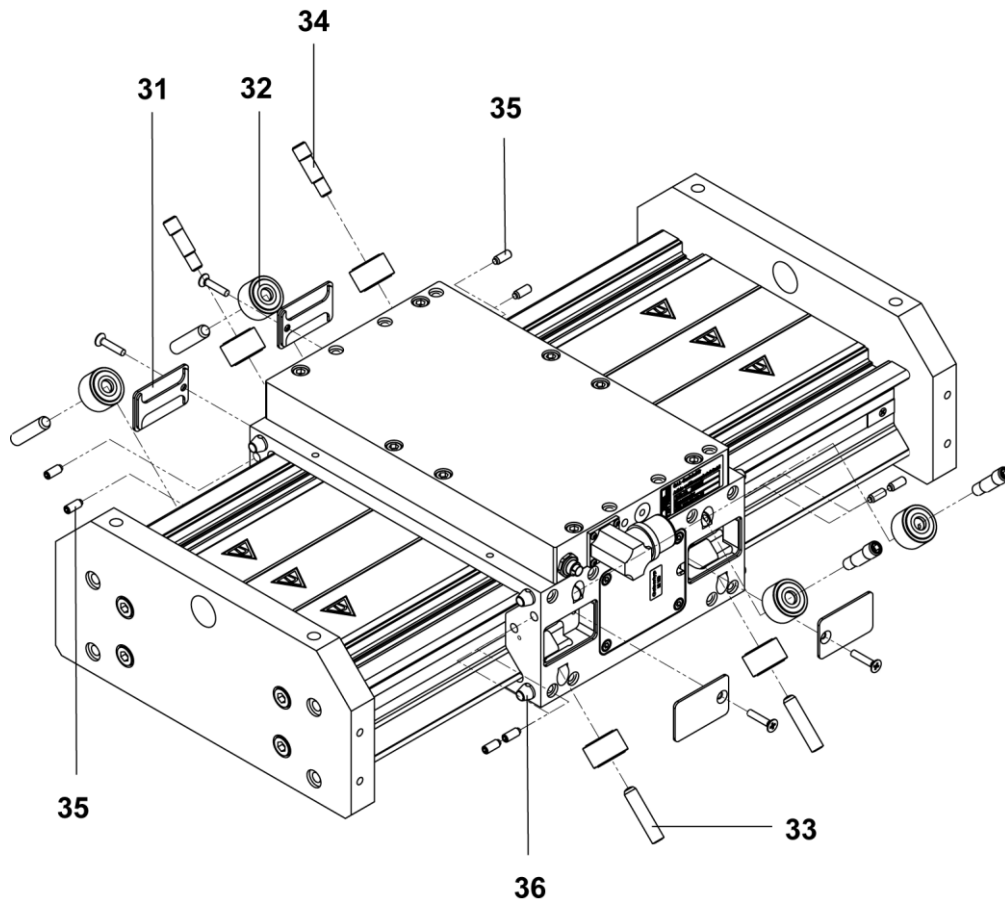

Figure 22: Spare parts – guide

Item	Type of axis	Designation	Quantity	GAS order no.
31a	T(U)	Roller cover	4	332 808
31b	T(U)L	Roller cover	4	341 769
32a	T(U)	Support roller	8	332 826
32b	T(U)L	Support roller	12	332 826
33a	T(U)	Support roller bearing	4	332 802
33b	T(U)L	Support roller bearing	8	332 802
34	All	Eccentric shaft	4	332 801
35	All	Pressure pin	8	300 176
36	All	Clamping element	8	300 891

12.6. Measuring system

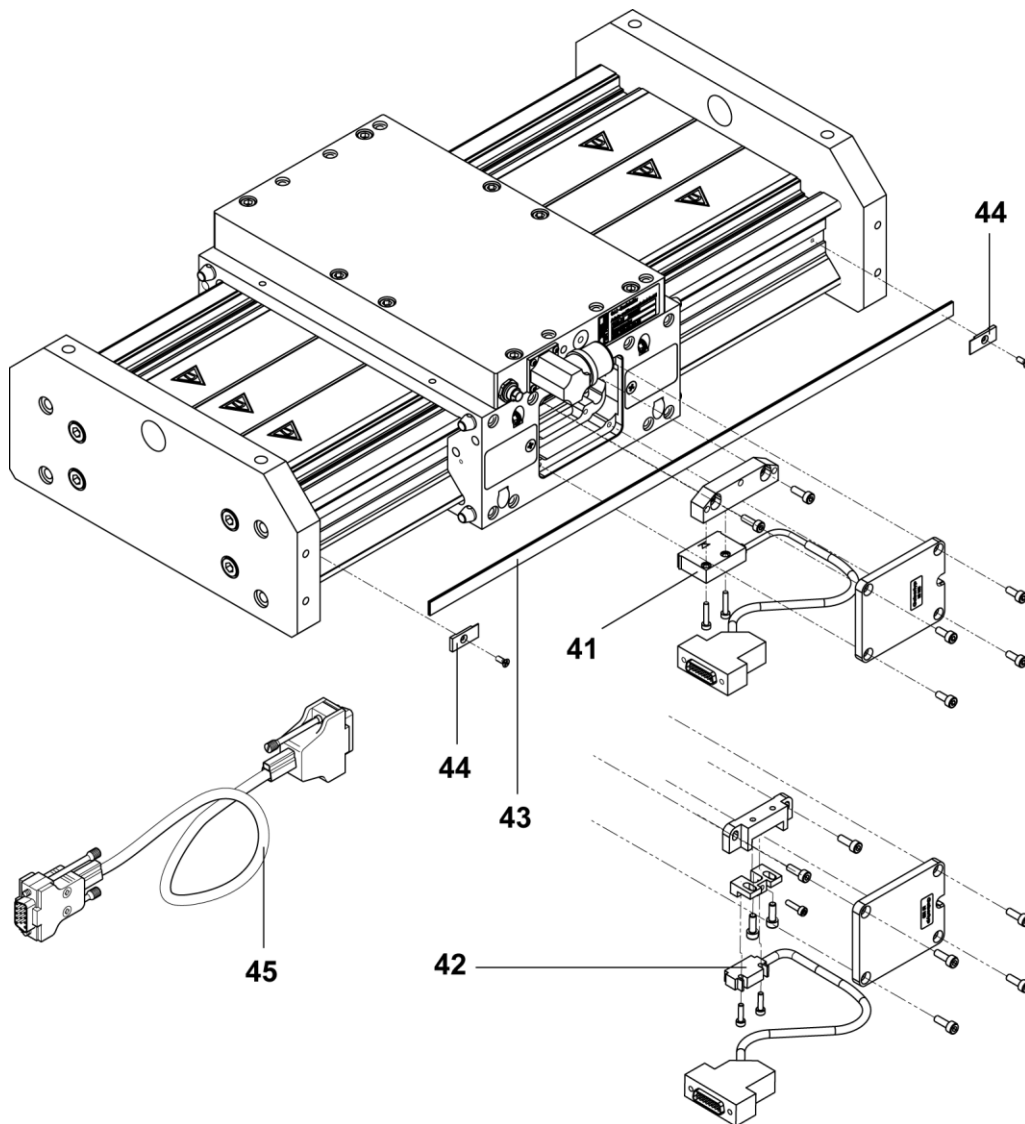

Figure 23: Spare parts – measuring system LE 100 / LS 100

Item	Type of axis	Designation	Quantity	Option	GAS order no.
41a	All	Reading head LE100 5 m	1		336 025
41b		Reading head LE100 10 m	1		341 782
42a	All	Reading head LS100 5 m	1		319 285
42b		Reading head LS100 10 m	1		323 292
43a	All	Ruler LE100	1	H	346 611
43b		Ruler LS100	1	H	311 706
44	All	Ruler clamping	2		333 991
45	All	Reference pulse cable LS100	1		323 160

12.7. Holding brake

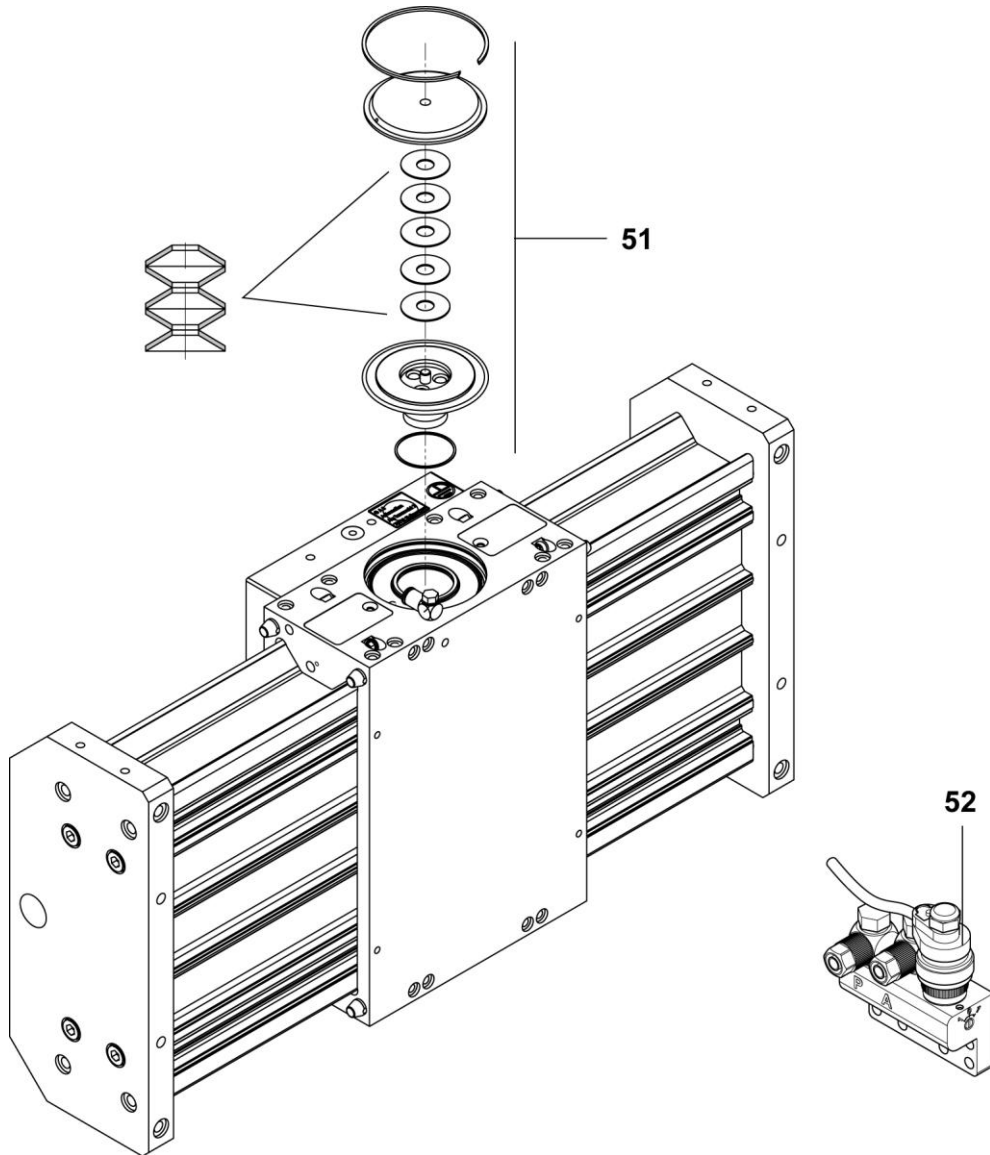

Figure 24: Spare parts – brake

Item	Type of axis	Designation	Quantity	GAS order no.
51a	T(U)	Installation set for pneumatic emergency	1	333 645
51b	T(U)L	stop brake	2	333 645
52	All	Brake valve, 10 m cable (GAS)	1	337 784
53	All	Brake valve, 10 m cable (Festo)	1	325 593

12.8. Accessories

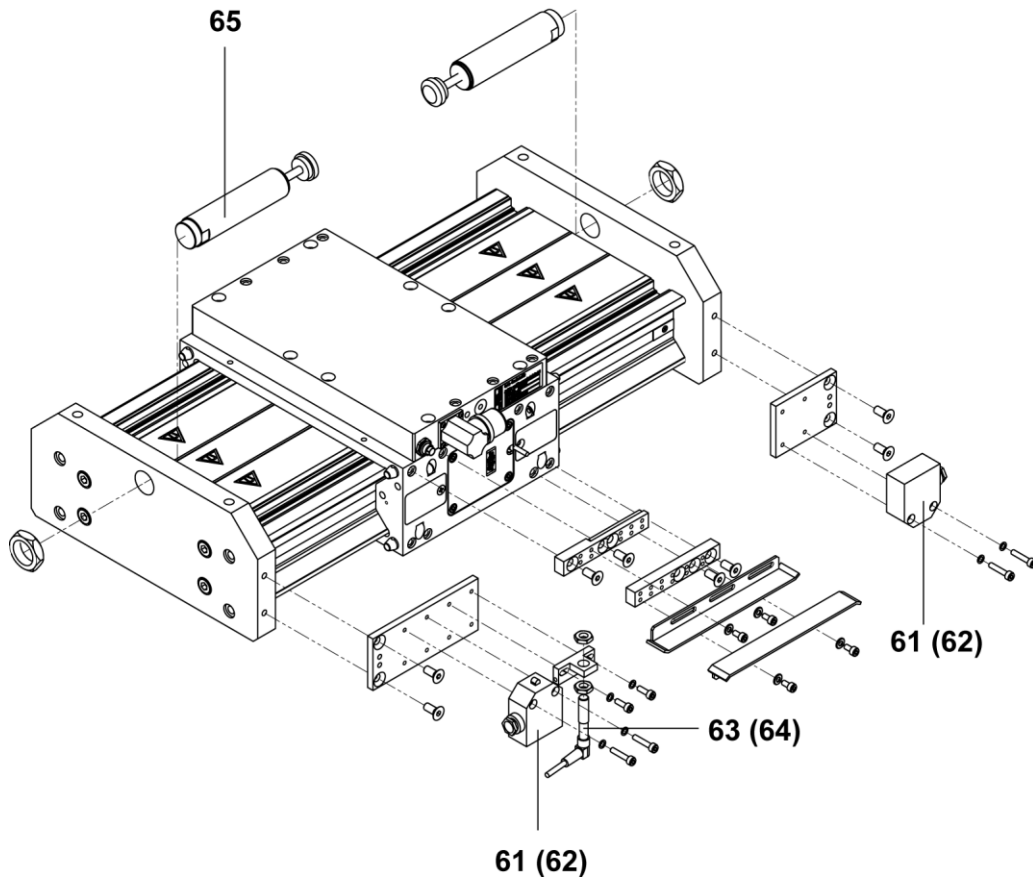

Figure 25: Spare parts – accessories

Item	Type of axis	Designation	Quantity	GAS order no.
61	All	Mechanical limit switch	2	308 190
62	All	Inductive limit switch	2	312 586
63	All	Inductive reference switch PNP	1	306 182
64	All	Inductive reference switch NPN	1	318 432
65	All	Shock absorber	2	319 701

13. EC declaration of incorporation

In terms of the EC Machinery Directive 2006/42/EC, annex II B

Manufacturer/ distributor SCHUNK GmbH & Co. KG.
Spann- und Greiftechnik
Bahnhofstr. 106 – 134
74348 Lauffen/Neckar, Germany

We hereby declare that the following product:

Product designation: Linearantrieb
Type designation: T, TL, TU, TUL
ID number: -

meets the applicable basic requirements of the Directive **Machinery (2006/42/EC)**.

The incomplete machine may not be put into operation until conformity of the machine into which the incomplete machine is to be installed with the provisions of the Machinery Directive (2006/42/EC) is confirmed.

Applied harmonized standards, especially:

EN ISO 12100-1 Safety of machines - Basic concepts, general principles for design -- Part 1:
Basic terminology, methodology
EN ISO 12100-2 Safety of machines - Basic concepts, general principles for design -- Part 2:
Technical principles

The manufacturer agrees to forward on demand the special technical documents for the incomplete machine to state offices.

The special technical documents according to Annex VII, Part B, belonging to the incomplete machine have been created.

Person responsible for documentation: Mr. Michael Eckert, Tel.: +49(0)7133/103-2204

Location, date/signature: Lauffen, Germany,
January 2010
Title of the signatory Director for Development

p.p. 

14. Contact



GERMANY – HEAD OFFICE

SCHUNK GmbH & Co. KG
Spann- und Greiftechnik
Bahnhofstrasse 106 – 134
D-Lauffen/Neckar
Tel. +49-7133-103-0
Fax +49-7133-103-2399
info@de.schunk.com
www.schunk.com



CANADA

SCHUNK Intec Corp.
190 Britannia Road East,
Units 23-24
Mississauga, ON L4Z 1W6
Tel. +1-905-712-2200
Fax +1-905-712-2210
info@ca.schunk.com
www.ca.schunk.com



DENMARK

SCHUNK Intec A/S
Storhaven 7
7100 Vejle
Tel. +45-43601339
Fax +45-43601492
info@dk.schunk.com
www.dk.schunk.com



HUNGARY

SCHUNK Intec Kft.
Széchenyi út. 70.
3530 Miskolc
Tel. +36-46-50900-7
Fax +36-46-50900-6
info@hu.schunk.com
www.hu.schunk.com



AUSTRIA

SCHUNK Intec GmbH
Holzbauernstr. 20
4050 Traun
Tel. +43-7229-65770-0
Fax +43-7229-65770-14
info@at.schunk.com
www.at.schunk.com



CHINA

SCHUNK GmbH & Co.KG
Shanghai
Representative Office
777 Zhao Jia Bang Road
Pine City Hotel, Room 923
Xuhui District
Shanghai 200032
Tel. +86-21-64433177
Fax +86-21-64431922
info@cn.schunk.com
www.cn.schunk.com



FRANCE

SCHUNK Intec SARL
Parc d'Activités des Trois
Noyers 15, Avenue James de
Rothschild
Ferrières-en-Brie
77614 Marne-la-Vallée
Cedex 3
Tel. +33-1-64 66 38 24
Fax +33-1-64 66 38 23
info@fr.schunk.com
www.fr.schunk.com



INDIA

SCHUNK India Branch Office
80 B, Yeswanthpur
Industrial Suburbs,
Bangalore 560 022
Tel. +91-80-41277361
Fax +91-80-41277363
info@in.schunk.com
www.in.schunk.com



BELGIUM, LUXEMBOURG

SCHUNK Intec N.V./S.A.
Bedrijvent centrum Regio Aalst
Industrielaan 4, Zuid III
9320 Aalst-Erembodegem
Tel. +32-53-853504
Fax +32-53-836022
info@be.schunk.com
www.be.schunk.com



CZECH REPUBLIC

SCHUNK Intec s.r.o.
Ernsta Macha 1
643 00 Brno
Tel. +420-545 229 095
Fax +420-545 220 508
info@cz.schunk.com
www.cz.schunk.com



GREAT BRITAIN, IRELAND

SCHUNK Intec Ltd.
Cromwell Business Centre
10 Howard Way,
Interchange Park
Newport Pagnell MK16 9QS
Tel. +44-1908-611127
Fax +44-1908-615525
info@gb.schunk.com
www.gb.schunk.com



ITALY

SCHUNK Intec S.r.l.
Via Barozzo
22075 Lurate Caccivio (CO)
Tel. +39-031-4951311
Fax +39-031-4951301
info@it.schunk.com
www.it.schunk.com

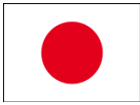

JAPAN

SCHUNK Intec K.K.
45-28 3-Chome Sanno
Ohta-Ku Tokyo 143-0023
Tel. +81-33-7743731
Fax +81-33-7766500
s-takano@tbk-hand.co.jp
www.tbk-hand.co.jp



POLAND

SCHUNK Intec Sp.z o.o.
Stara Iwiczna,
ul. Słoneczna 116 A
05-500 Piaseczno
Tel. +48-22-7262500
Fax +48-22-7262525
info@pl.schunk.com
www.pl.schunk.com



SOUTH KOREA

SCHUNK Intec Korea Ltd.
907 Joongang
Induspia 2 Bldg.,
144-5 Sangdaewon-dong
Jungwon-gu, Seongnam-si
Kyunggi-do, 462-722
Tel. +82-31-7376141
Fax +82-31-7376142
info@kr.schunk.com
www.kr.schunk.com



**SWITZERLAND,
LIECHTENSTEIN**

SCHUNK Intec AG
Soodring 19
8134 Adliswil 2
Tel. +41-44-7102171
Fax +41-44-7102279
info@ch.schunk.com
www.ch.schunk.com



MEXICO, VENEZUELA

SCHUNK Intec S.A. de C.V.
Av. Luis Vega y Monroy # 332
Fracc. Plazas de Sol
Santiago de Querétaro,
Qro. 76099
Tel. +52-442-223-6525
Fax +52-442-223-7665
info@mx.schunk.com
www.mx.schunk.com



PORTUGAL

Sales Representative
Victor Marques
Tel. +34-937-556 020
Fax +34-937-908 692
Mobil +351-963-786 445
info@pt.schunk.com
www.pt.schunk.com



SPAIN

SCHUNK Intec S.L.
Foneria, 27
08304 Mataró (Barcelona)
Tel. +34-937 556 020
Fax +34-937 908 692
info@es.schunk.com
www.es.schunk.com



TURKEY

SCHUNK Intec
Bağlama Sistemleri ve
Otomasyon San. ve Tic. Ltd. Şti.
Küçükyalı İş Merkezi
Girne Mahallesi
Irmak Sodak, A Blok, No: 9
34852 Maltepe, Istanbul
Tel. +90-216-366-2111
Fax +90-216-366-2277
info@tr.schunk.com
www.tr.schunk.com



NETHERLANDS

SCHUNK Intec B.V.
Speldenmakerstraat 3d
5232 BH 's-Hertogenbosch
Tel. +31-73-6441779
Fax +31-73-6448025
info@nl.schunk.com
www.nl.schunk.com



SLOVAKIA

SCHUNK Intec s.r.o.
Mostná 62
919 01 Nitra
Tel. +421-37-3260610
Fax +421-37-6421906
info@sk.schunk.com
www.sk.schunk.com



SWEDEN

SCHUNK Intec AB
Morabergsvägen 28
152 42 Södertälje
Tel. +46-8 554 421 00
Fax +46-8 554 421 01
info@se.schunk.com
www.se.schunk.com



USA

SCHUNK Intec Inc.
211 Kitty Hawk Drive
Morrisville, NC 27560
Tel. +1-919-572-2705
Fax +1-919-572-2818
info@us.schunk.com
www.us.schunk.com