

Assembly and Operating Manual

GWK-A

Gripper changing head

Translation of original operating manual

Imprint

Copyright:

This manual is protected by copyright. The author is SCHUNK SE & Co. KG.
All rights reserved.

Technical changes:

We reserve the right to make alterations for the purpose of technical improvement.

Document number: 389131

Version: 06.00 | 24/08/2023 | en

Dear Customer,

Thank you for trusting our products and our family-owned company, the leading technology supplier of robots and production machines.

Our team is always available to answer any questions on this product and other solutions. Ask us questions and challenge us. We will find a solution!

Best regards,

Your SCHUNK team

Customer Management

Tel. +49-7133-103-2503

Fax +49-7133-103-2189

cmg@de.schunk.com



Please read the operating manual in full and keep it close to the product.

Table of Contents

1 General	5
1.1 About this manual.....	5
1.1.1 Presentation of Warning Labels	5
1.1.2 Applicable documents	6
1.2 Warranty	6
1.3 Scope of delivery.....	6
1.3.1 Accessories kit	6
1.4 Accessories	7
1.4.1 Seal kit	7
2 Basic safety notes	8
2.1 Intended use.....	8
2.2 Not intended use	8
2.3 Constructional changes.....	8
2.4 Spare parts	9
2.5 Ambient conditions and operating conditions	9
2.6 Personnel qualification	9
2.7 Personal protective equipment	10
2.8 Notes on safe operation.....	10
2.9 Transport.....	11
2.10 Malfunctions.....	11
2.11 Disposal	11
2.12 Fundamental dangers	12
2.12.1 Protection during handling and assembly	12
2.12.2 Protection during commissioning and operation	12
2.12.3 Protection against dangerous movements	12
2.12.4 Protection against electric shock.....	13
2.13 Notes on particular risks	14
3 Technical data	15
4 Assembly	16
4.1 Fixing and connection.....	16
4.2 Electrical plug connector.....	20
4.3 Mounting the sensor.....	22
4.3.1 Inductive proximity switch IN 80	22
5 Maintenance	25
5.1 Notes.....	25
5.2 Maintenance intervals.....	25
5.3 Lubricants/Lubrication points (basic lubrication)	25

5.4 Dismantling the product	26
5.5 Servicing and assembling the product	27
5.5.1 Changing the socket part (20).....	27
5.6 Assembly drawing	28
6 Troubleshooting.....	31
7 Translation of the original declaration of incorporation	32
8 UKCA declaration of incorporation	33
9 Information on the RoHS Directive, REACH Regulation and Substances of Very High Concern (SVHC)	34

1 General

1.1 About this manual

This manual contains important information for a safe and appropriate use of the product.

This manual is an integral part of the product and must be kept accessible for the personnel at all times.

Before starting work, the personnel must have read and understood this operating manual. Prerequisite for safe working is the observance of all safety instructions in this manual.

In addition to these instructions, the documents listed under ▶ 1.1.2 [6] are applicable.

NOTE: The illustrations in this manual are intended to provide a basic understanding and may deviate from the actual version.

1.1.1 Presentation of Warning Labels

To make risks clear, the following signal words and symbols are used for safety notes.



⚠ DANGER

Dangers for persons!

Non-observance will inevitably cause irreversible injury or death.



⚠ WARNING

Dangers for persons!

Non-observance can lead to irreversible injury and even death.



⚠ CAUTION

Dangers for persons!

Non-observance can cause minor injuries.

CAUTION

Material damage!

Information about avoiding material damage.

1.1.2 Applicable documents

- General terms of business *
- Catalog data sheet of the purchased product *
- Assembly and operating manuals of the accessories *

The documents labeled with an asterisk (*) can be downloaded from schunk.com.

1.2 Warranty

If the product is used as intended, the warranty is valid for 24 months from the ex-works delivery date under the following conditions:

- Observe the specified maintenance and lubrication intervals
- Observe the ambient conditions and operating conditions

Parts touching the workpiece and wear parts are not included in the warranty.

1.3 Scope of delivery

The scope of delivery includes

- Gripper changing head GWK-A in the version ordered
- Assembly and Operating Manual
- Accessory pack

1.3.1 Accessories kit

Content of the accessory pack:

- 1 x key
- Screws for fastening
- Swivel fittings
- 2 x cylindrical pin
- Elbow connectors (size 125)

Accessory pack for	ID number
GWK-A 64	5510643
GWK-A 80	5510644
GWK-A 125	5510645

1.4 Accessories

The following accessories, which must be ordered separately, are required for the product:

- Sensors
- Gripper change magazine

For information regarding which accessory articles can be used with the corresponding product variants, see catalog data sheet.

1.4.1 Seal kit

Content of the sealing kit:

- Quad ring
- O-rings
- Sealing rings

Seal kit for	ID number
GWK-A 64	0370810
GWK-A 80	0370811
GWK-A 125	0370812

2 Basic safety notes

2.1 Intended use

The product is only intended to be used for automatic changing of robot tools (e.g. grippers, pneumatically or electrically driven tools, electrode holders etc.).

- The product may only be used within the scope of its technical data, ▶ 3 [15].
- When implementing and operating components in safety-related parts of the control systems, the basic safety principles in accordance with DIN EN ISO 13849-2 apply. The proven safety principles in accordance with DIN EN ISO 13849-2 also apply to categories 1, 2, 3 and 4.
- The product is intended for installation in a machine/ automated system. The applicable guidelines for the machine/ automated system must be observed and complied with.
- The product is intended for industrial and industry-oriented use.
- Appropriate use of the product includes compliance with all instructions in this manual.

2.2 Not intended use

It is not intended use if the product is used, for example, as a pressing tool, stamping tool, lifting gear, guide for tools, cutting tool, clamping device or a drilling tool.

- Any utilization that exceeds or differs from the appropriate use is regarded as misuse.

2.3 Constructional changes

Implementation of structural changes

By conversions, changes, and reworking, e.g. additional threads, holes, or safety devices can impair the functioning or safety of the product or damage it.

- Structural changes should only be made with the written approval of SCHUNK.

2.4 Spare parts

Use of unauthorized spare parts

Using unauthorized spare parts can endanger personnel and damage the product or cause it to malfunction.

- Use only original spare parts or spares authorized by SCHUNK.

2.5 Ambient conditions and operating conditions

Required ambient conditions and operating conditions

Incorrect ambient and operating conditions can make the product unsafe, leading to the risk of serious injuries, considerable material damage and/or a significant reduction to the product's life span.

- Make sure that the product is used only in the context of its defined application parameters, ▶ 3 [15].
- Make sure that the product is a sufficient size for the application.
- Make sure that the environment is free from splash water and vapors as well as from abrasion or processing dust. Exceptions are products that are designed especially for contaminated environments.

2.6 Personnel qualification

Inadequate qualifications of the personnel

If the personnel working with the product is not sufficiently qualified, the result may be serious injuries and significant property damage.

- All work may only be performed by qualified personnel.
- Before working with the product, the personnel must have read and understood the complete assembly and operating manual.
- Observe the national safety regulations and rules and general safety instructions.

The following personal qualifications are necessary for the various activities related to the product:

Trained electrician

Due to their technical training, knowledge and experience, trained electricians are able to work on electrical systems, recognize and avoid possible dangers and know the relevant standards and regulations.

Qualified personnel	Due to its technical training, knowledge and experience, qualified personnel is able to perform the delegated tasks, recognize and avoid possible dangers and knows the relevant standards and regulations.
Instructed person	Instructed persons were instructed by the operator about the delegated tasks and possible dangers due to improper behaviour.
Service personnel of the manufacturer	Due to its technical training, knowledge and experience, service personnel of the manufacturer is able to perform the delegated tasks and to recognize and avoid possible dangers.

2.7 Personal protective equipment

Use of personal protective equipment

Personal protective equipment serves to protect staff against danger which may interfere with their health or safety at work.

- When working on and with the product, observe the occupational health and safety regulations and wear the required personal protective equipment.
- Observe the valid safety and accident prevention regulations.
- Wear protective gloves to guard against sharp edges and corners or rough surfaces.
- Wear heat-resistant protective gloves when handling hot surfaces.
- Wear protective gloves and safety goggles when handling hazardous substances.
- Wear close-fitting protective clothing and also wear long hair in a hairnet when dealing with moving components.

2.8 Notes on safe operation

Incorrect handling of the personnel

Incorrect handling and assembly may impair the product's safety and cause serious injuries and considerable material damage.

- Avoid any manner of working that may interfere with the function and operational safety of the product.
- Use the product as intended.
- Observe the safety notes and assembly instructions.
- Do not expose the product to any corrosive media. This does not apply to products that are designed for special environments.
- Eliminate any malfunction immediately.
- Observe the care and maintenance instructions.

- Observe the current safety, accident prevention and environmental protection regulations regarding the product's application field.

2.9 Transport

Handling during transport

Incorrect handling during transport can make the product unsafe and risk the danger of serious injuries and considerable material damage.

- During transport and handling, secure the product to prevent it from falling.
- Do not walk under suspended loads.

2.10 Malfunctions

Behavior in case of malfunctions

- Immediately remove the product from operation and report the malfunction to the responsible departments/persons.
- Order appropriately trained personnel to rectify the malfunction.
- Do not recommission the product until the malfunction has been rectified.
- Test the product after a malfunction to establish whether it still functions properly and no increased risks have arisen.

2.11 Disposal

Handling of disposal

The incorrect handling of disposal may impair the product's safety and cause serious injuries as well as considerable material and environmental harm.

- Follow local regulations on dispatching product components for recycling or proper disposal.

2.12 Fundamental dangers

General

- Observe safety distances.
- Never deactivate safety devices.
- Before commissioning the product, take appropriate protective measures to secure the danger zone.
- Disconnect power sources before installation, modification, maintenance, or calibration. Ensure that no residual energy remains in the system.
- If the energy supply is connected, do not move any parts by hand.
- Do not reach into the open mechanism or movement area of the product during operation.

2.12.1 Protection during handling and assembly

Incorrect handling and assembly

Incorrect handling and assembly may impair the product's safety and cause serious injuries and considerable material damage.

- Have all work carried out by appropriately qualified personnel.
- For all work, secure the product against accidental operation.
- Observe the relevant accident prevention rules.
- Use suitable assembly and transport equipment and take precautions to prevent jamming and crushing.

Incorrect lifting of loads

Falling loads may cause serious injuries and even death.

- Stand clear of suspended loads and do not step into their swiveling range.
- Never move loads without supervision.
- Do not leave suspended loads unattended.

2.12.2 Protection during commissioning and operation

Falling or violently ejected components

Falling and violently ejected components can cause serious injuries and even death.

- Take appropriate protective measures to secure the danger zone.
- Never step into the danger zone during operation.

2.12.3 Protection against dangerous movements

Unexpected movements

Residual energy in the system may cause serious injuries while working with the product.

- Switch off the energy supply, ensure that no residual energy remains and secure against inadvertent reactivation.
- Never rely solely on the response of the monitoring function to avert danger. Until the installed monitors become effective, it must be assumed that the drive movement is faulty, with its action being dependent on the control unit and the current operating condition of the drive. Perform maintenance work, modifications, and attachments outside the danger zone defined by the movement range.
- To avoid accidents and/or material damage, human access to the movement range of the machine must be restricted. Limit/prevent accidental access for people in this area due through technical safety measures. The protective cover and protective fence must be rigid enough to withstand the maximum possible movement energy. EMERGENCY STOP switches must be easily and quickly accessible. Before starting up the machine or automated system, check that the EMERGENCY STOP system is working. Prevent operation of the machine if this protective equipment does not function correctly.

2.12.4 Protection against electric shock

Possible electrostatic energy

Components or assembly groups may become electrostatically charged. When the electrostatic charge is touched, the discharge may trigger a shock reaction leading to injuries.

- The operator must ensure that all components and assembly groups are included in the local potential equalisation in accordance with the applicable regulations.
- While paying attention to the actual conditions of the working environment, the potential equalisation must be implemented by a specialist electrician according to the applicable regulations.
- The effectiveness of the potential equalisation must be verified by executing regular safety measurements.

2.13 Notes on particular risks



⚠ DANGER

Risk of fatal injury from suspended loads!

Falling loads can cause serious injuries and even death.

- Stand clear of suspended loads and do not step within their swiveling range.
- Never move loads without supervision.
- Do not leave suspended loads unattended.
- Wear suitable protective equipment.



⚠ WARNING

Risk of injury from objects falling and being ejected!

Falling and ejected objects during operation can lead to serious injury or death.

- Take appropriate protective measures to secure the danger zone.



⚠ WARNING

Risk of injury due to unexpected movements!

If the power supply is switched on or residual energy remains in the system, components can move unexpectedly and cause serious injuries.

- Before starting any work on the product: Switch off the power supply and secure against restarting.
- Make sure, that no residual energy remains in the system.



⚠ WARNING

Risk of injury from sharp edges and corners!

Sharp edges and corners can cause cuts.

- Use suitable protective equipment.

3 Technical data

	GWK-A 64	GWK-A 80	GWK-A 125
Weight [kg]	0.74	0.95	2.6
Maximum payload [kg]	60	86	170
Pneumatic energy transmission	4x M5 and 2x G1/8"	6x M5 and 2x G1/8"	8x G1/8" and 2x G1/4"
Electrical energy transmission	2 x 18 pins 60V/1A		
Min./max. distance during locking [mm]	2		
Max. permissible XY axis offset [mm]	1.5		
Max. permissible angular offset [°]	1		
Repeatability [mm]	0.02		
Noise emission [dB(A)]	≤ 70		

More technical data is included in the catalog data sheet. Whichever is the latest version.

4 Assembly

4.1 Fixing and connection

Evenness of the mounting surface

The values apply to the whole mounting surface to which the product is mounted.

Edge length	Permissible unevenness
< 100	< 0.02
> 100	< 0.05

Tab.: Requirements for evenness of the mounting surface (Dimensions in mm)

NOTE

When inductive proximity switches are to be fitted, these must be inserted and secured in place before fixing the GWK-A in place.

Options for fixing the GWK-A in place:

- Centering shoulder and a cylindrical pin
- Two cylindrical pins

GWK-A 64

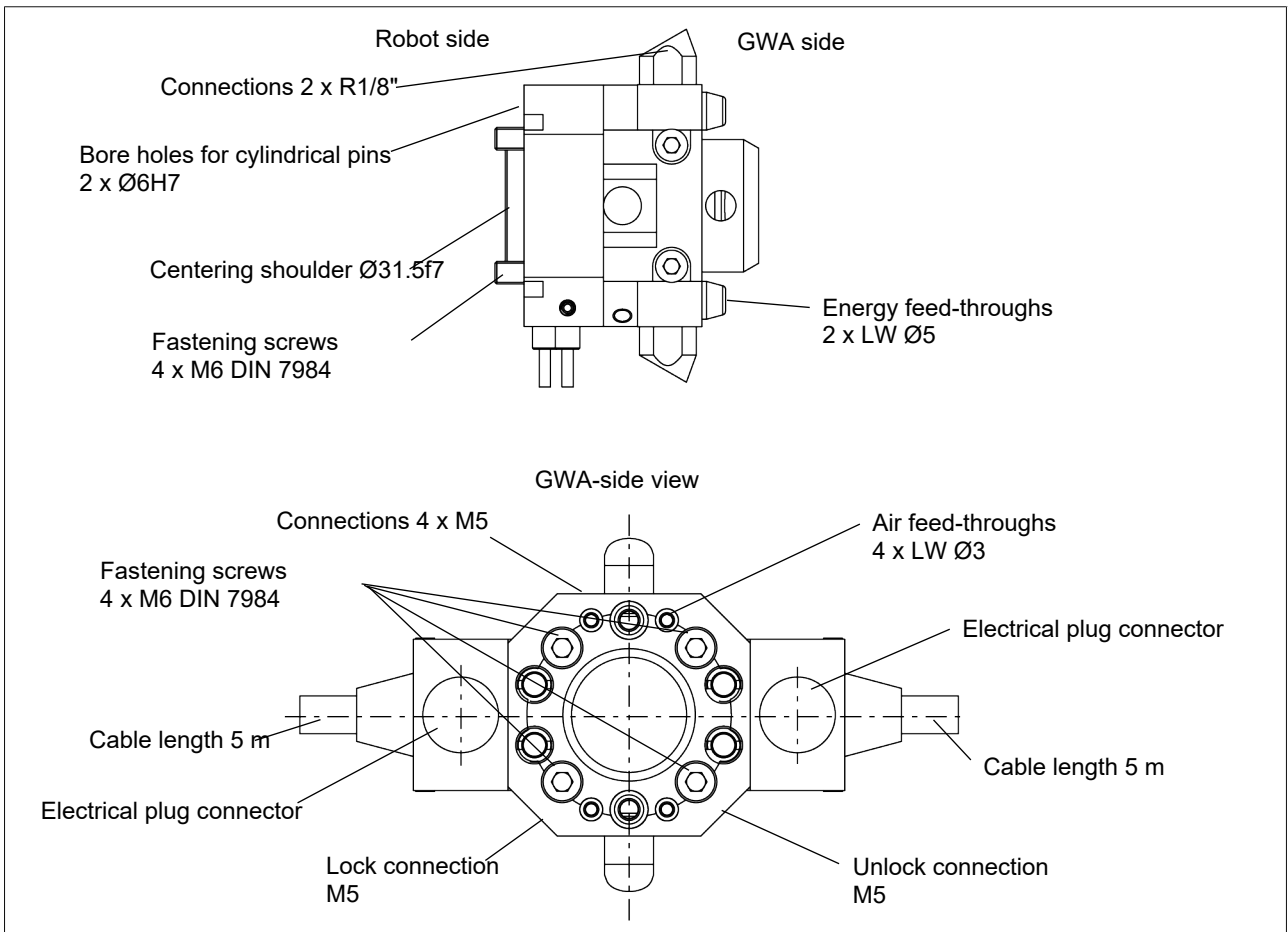

GWK-A 64

GWK-A 80

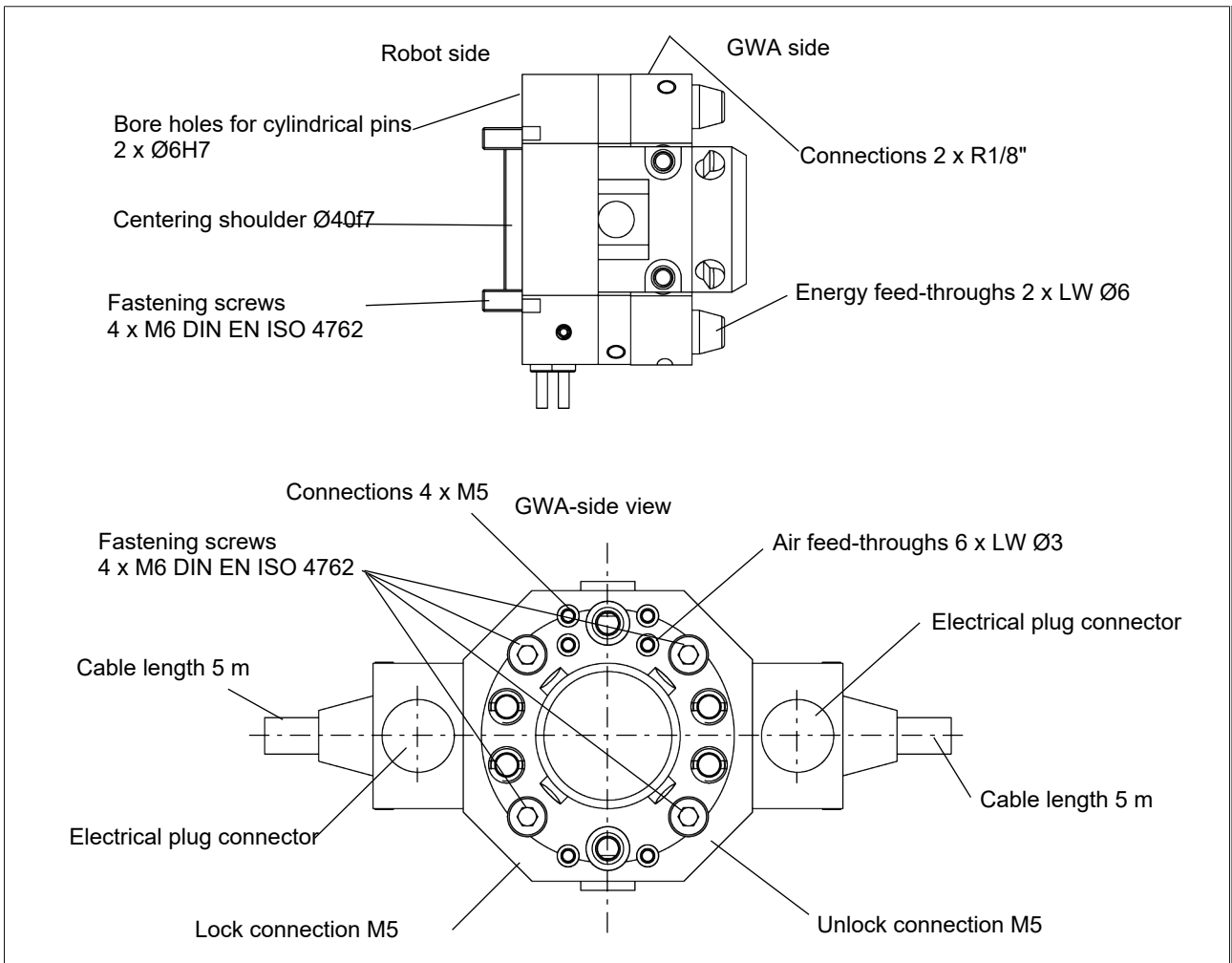

GWK-A 80

GWK-A 125

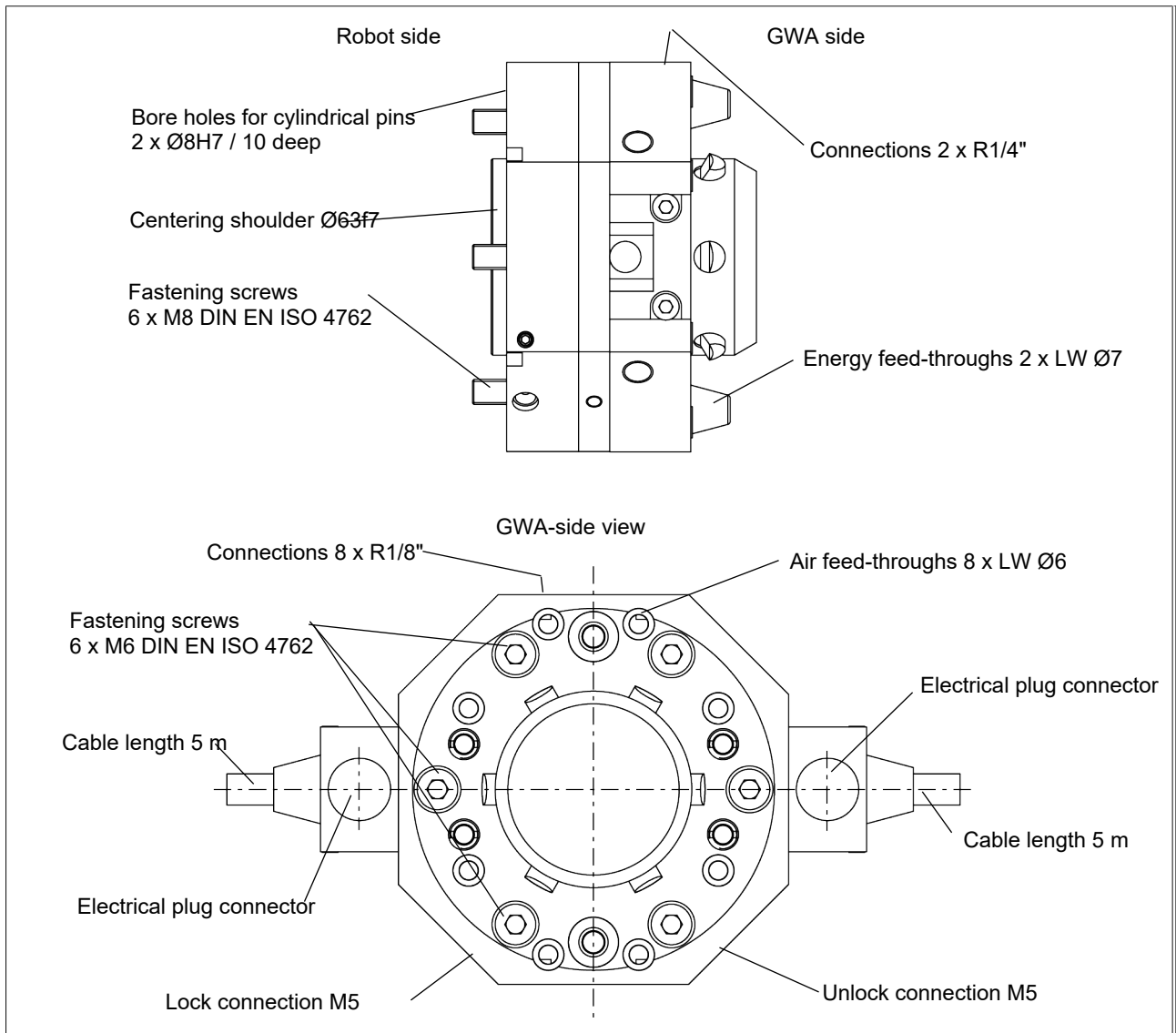

GWK-A 125

4.2 Electrical plug connector

NOTE

The cables must not be constantly moved up to the cable exit (risk of fracture).

The last cable clip is to be placed 100 – 300mm before the cable exit.

The minimum bending radius of the cable is 15 x cable \varnothing .

The bending radius can be less than the minimum where the cable is laid in such a way that it is rigid.

NOTE

The cable diameter is 8.5mm. The cable housing and plug connector are designed in accordance with VDE directives.

Connector assignments

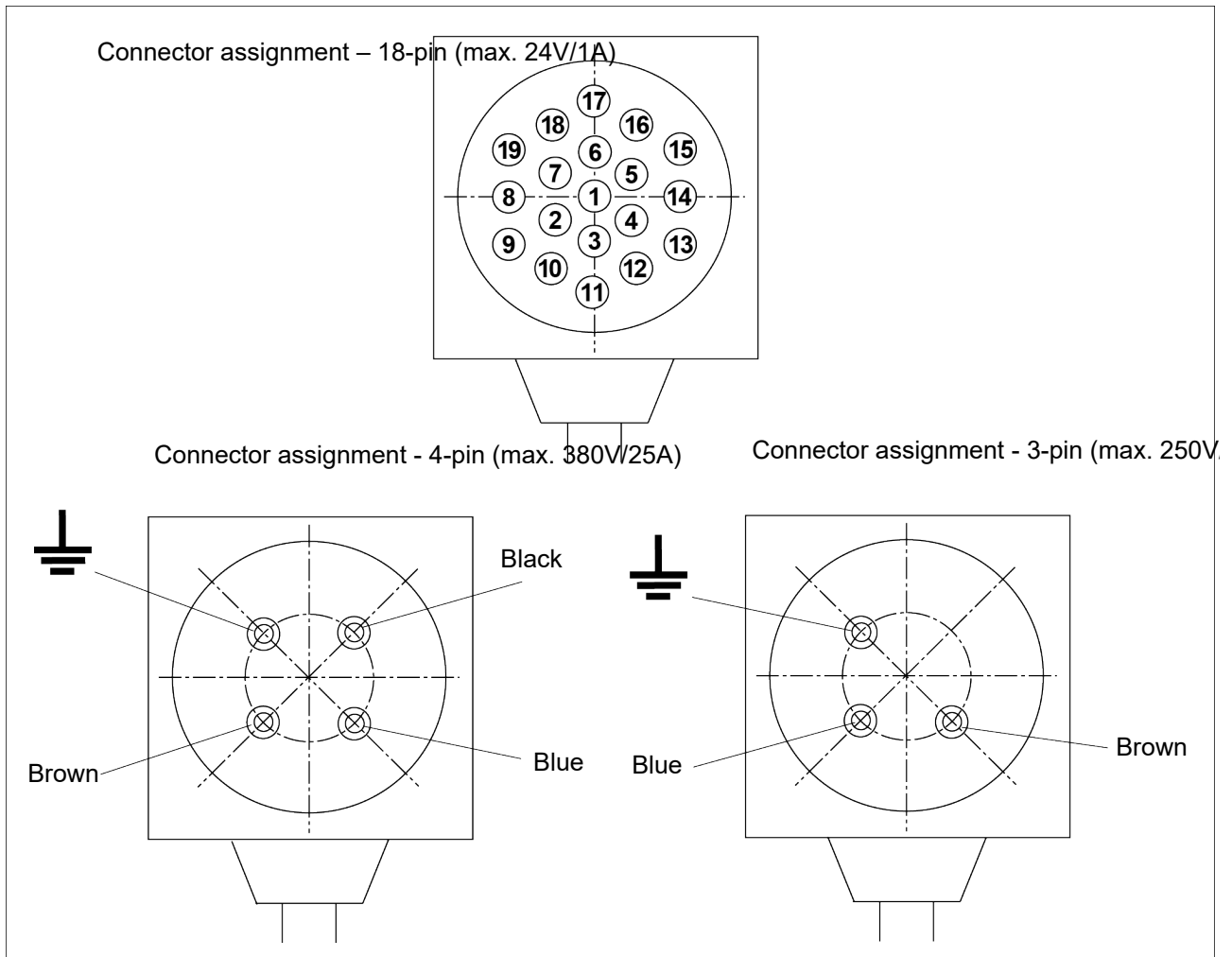

1	not assigned	11	blue
2	white-yellow	12	red
3	yellow-brown	13	black
4	white-gray	14	purple
5	gray-brown	15	gray-red
6	white-green	16	red-blue
7	brown-green	17	white
8	yellow	18	brown
9	gray	19	green
10	pink		
18-pin	Lapp unitronic FD-D 18x0.14mm ²		
3-pin	Lapp Ölflex 500 P 3x1.5mm ²		
4-pin	Lapp Ölflex 500 P 4x2.5mm ²		

4.3 Mounting the sensor

NOTE

Observe the assembly and operating manual of the sensor for mounting and connecting.

The product is equipped for the use of sensors.

- For the exact type designations of suitable sensors, please see the catalog data sheet.
- For technical data for the suitable sensors, see Assembly and Operating Manual and catalog data sheet.
 - The Assembly and Operating Manual and catalog data sheet are included in the scope of delivery for the sensors and are available at schunk.com.
- Information on handling sensors is available at schunk.com or from SCHUNK contact persons.

4.3.1 Inductive proximity switch IN 80

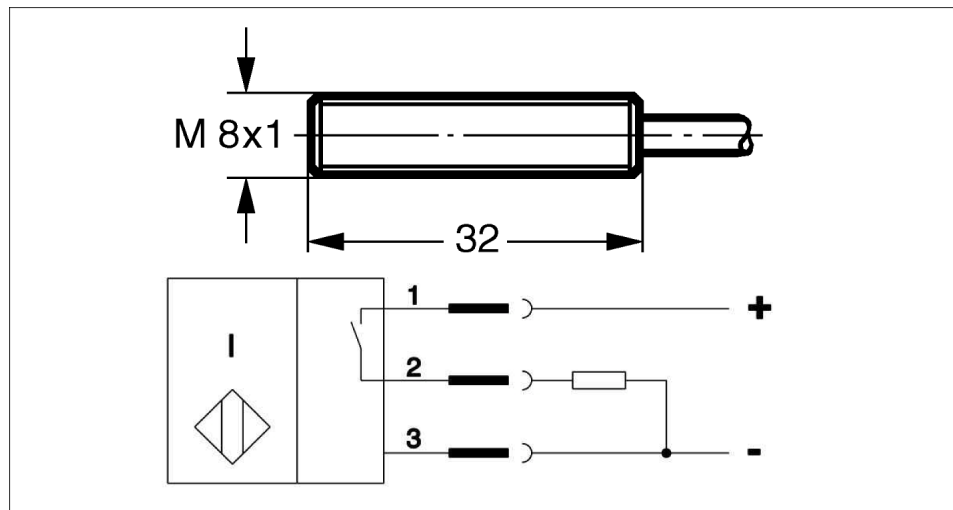

Connection example for IN 80

1	brown	2	black	3	blue
---	-------	---	-------	---	------

The inductive proximity switches used are equipped with reverse polarity protection and are short-circuit-proof.

Make sure that you handle the proximity switches properly:

- Do not pull on the cable.
- Do not allow the sensor to dangle from the cable.
- Do not overtighten the mounting screw or mounting clip.
- Please adhere to a permitted bend radius of the cable. (→ catalog)

- Avoid contact of the proximity switches with hard objects and with chemicals, in particular nitric acid, chromic acid and sulphuric acid.

The inductive proximity switches are electronic components, which can react sensitively to high-frequency interference or electromagnetic fields.

- Check to make sure that the cable is fastened and installed correctly. Provide for sufficient clearance to sources of high-frequency interference and their supply cables.
- Parallel switching of several sensor outputs of the same type (npn, pnp) is permissible, but does not increase the permissible load current.
- Note that the leakage current of the individual sensors (ca. 2 mA) is cumulative.

Installing the proximity switches for coding

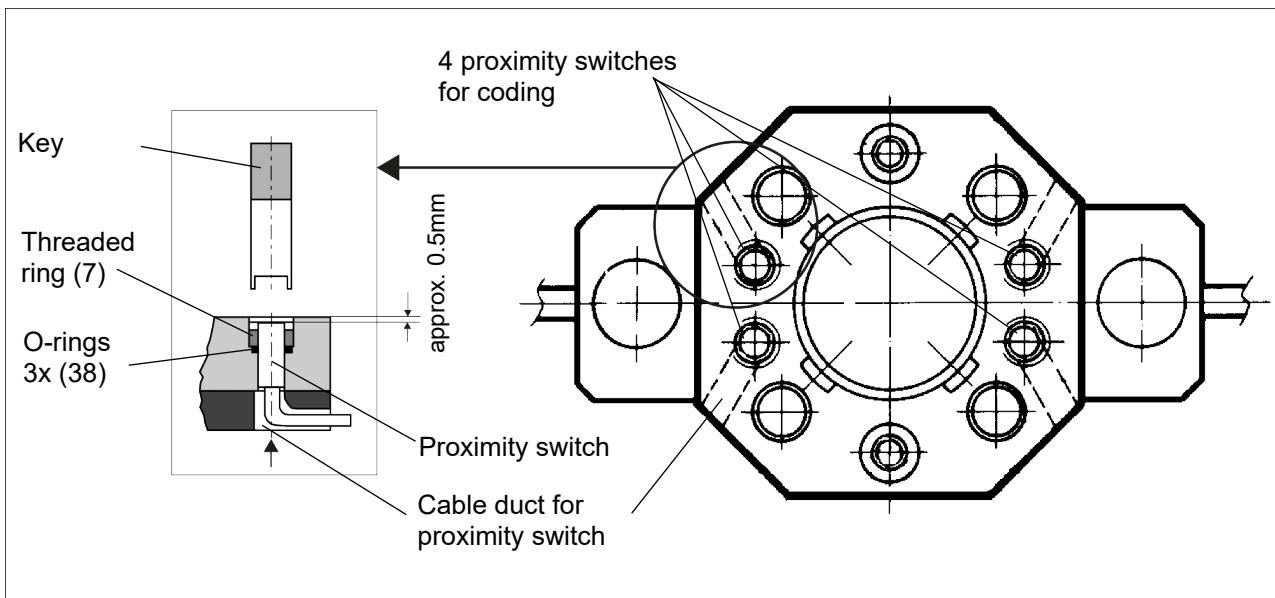

1. Loosen the threaded ring with the key.
2. Slide proximity switch into the opening for the proximity switch in the direction of the arrow.
3. Secure the proximity switch with the threaded ring.
4. Connect all proximity switches and test the function.

Installation of proximity switches for locked/unlocked status monitoring

1. Insert the clamping sleeves (42) into the base (25). The clamping sleeves should be flush with the base.
2. Push the proximity switches (N1 and N2) into the base (25) through the clamping sleeves up to the internal back stop.
3. Using the set-screws (23) on the side of the base, fix the proximity switches in place to prevent them from being displaced.
4. Connect the proximity switches.
5. Lock and unlock the gripper changing head in order to test if the proximity switches are working.

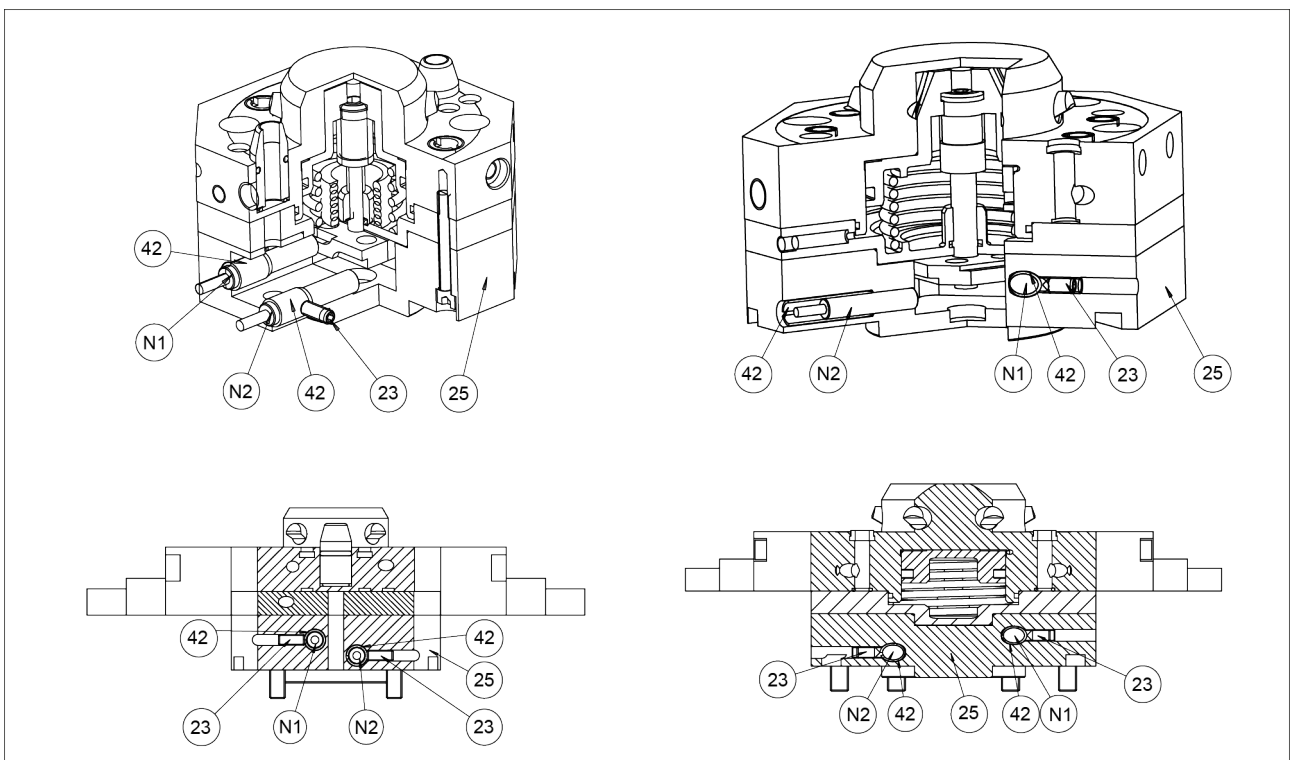

Left: GWK-A 64/ GWK-A 80, right: GWK-A 125

Function of the proximity switches:

- Proximity switch N1: GWK-A locked
- Proximity switch N2: GWK-A unlocked

5 Maintenance

5.1 Notes

The piston, clamping pins and taper are calibrated to each other in the housing.

To replace these parts, send the entire GWK-A to SCHUNK with a repair order.

It is useful to have SCHUNK perform maintenance and replace seals because the piston and clamping pins have to be aligned when assembled.

5.2 Maintenance intervals

CAUTION

Material damage due to hardening lubricants!

Lubricants harden more quickly at temperatures above 60°C, leading to possible product damage.

- Reduce the lubricant intervals accordingly.

Size	64 - 125
Interval [Mio. cycles]	2

5.3 Lubricants/Lubrication points (basic lubrication)

During maintenance, treat all greased areas with lubricant. Thinly apply lubricant with a lint-free cloth.

SCHUNK recommends the lubricants listed.

Greasing area	Lubricant
Metallic sliding surfaces	Rivolta F.L.G. GT-2
All seals	Rivolta F.L.G. GT-2

The product contains food-compliant lubricants as standard.

The requirements of standard EN 1672-2:2020 are not fully met.

NOTE

- Change contaminated food-compliant lubricant.
- Observe information in the safety data sheet from the lubricant manufacturer.

5.4 Dismantling the product

Position of the item numbers ▶ 5.6 [28]



⚠ WARNING

Risk of injury due to unexpected movements!

If the power supply is switched on or residual energy remains in the system, components can move unexpectedly and cause serious injuries.

- Before starting any work on the product: Switch off the power supply and secure against restarting.
- Make sure, that no residual energy remains in the system.

1. Remove the pressure lines and socket parts (20). Disconnect the plug connector for the proximity switch.
2. Unscrew the GWK-A from the handling unit.



⚠ WARNING

Risk of injury due to components being ejected!

The GWK-A is equipped with a clamping force lock. A defect may cause the intermediate plate (3) and the base (25) to be under spring tension.

- Disassemble the GWK-A carefully.
3. Carefully clamp the GWK-A between pos. "a" and pos. "b".
 4. Remove the two screws (17) and slowly unclamp the GWK-A.

NOTE

The piston and clamping pins have been coordinated to one another. Mark the installation position of these parts in the housing.

5. Remove the base (25).
6. Pull the intermediate plate (3) out of the housing.
7. Unscrew the screw (27) carefully.



⚠ WARNING

Loosening the screw (27) will cause the piston (11) and the intermediate plate (3) to be pushed apart by the springs of the clamping force lock.

The piston (11) and monitoring bolt (29) have been coordinated to one another. These parts must neither be separated nor adjusted.

8. Remove the seals (34, 35, 36, 37, 38, 39, 41).

5.5 Servicing and assembling the product

Maintenance

- Clean all parts thoroughly and check for damage and wear.
- Treat all greased areas with lubricant.
 - ▶ 5.3 [📄 25]
- Oil or grease bare external steel parts.
- Replace all wear parts / seals.
 - Position of the wearing parts ▶ 5.6 [📄 28]
 - Seal kit ▶ 1.4.1 [📄 7]
- The contact surfaces on the GWK gripper changing head, the pins and the centering taper for the connector parts must always be clean.
- Make sure that the connector parts have noticeable axial and radial play.
If this is not the case, remove the connector parts, clean everything thoroughly and screw the connector parts back on.
- If the GWK gripper changing head is cleaned and maintained, the GWA gripper change adapter should also be cleaned thoroughly.

Assembly

Assembly takes place in the opposite order to disassembly. Observe the following:

- Unless otherwise specified, secure all screws and nuts with Loctite no. 243 and tighten with the appropriate tightening torque.

5.5.1 Changing the socket part (20)

1. Remove the screws (15) and replace the electrical plug connector (20).
2. Align the electrical plug connector parallel to surface "C" ▶ 5.6 [📄 28].

CAUTION The electrical plug connector must not project beyond surface "C".

5.6 Assembly drawing

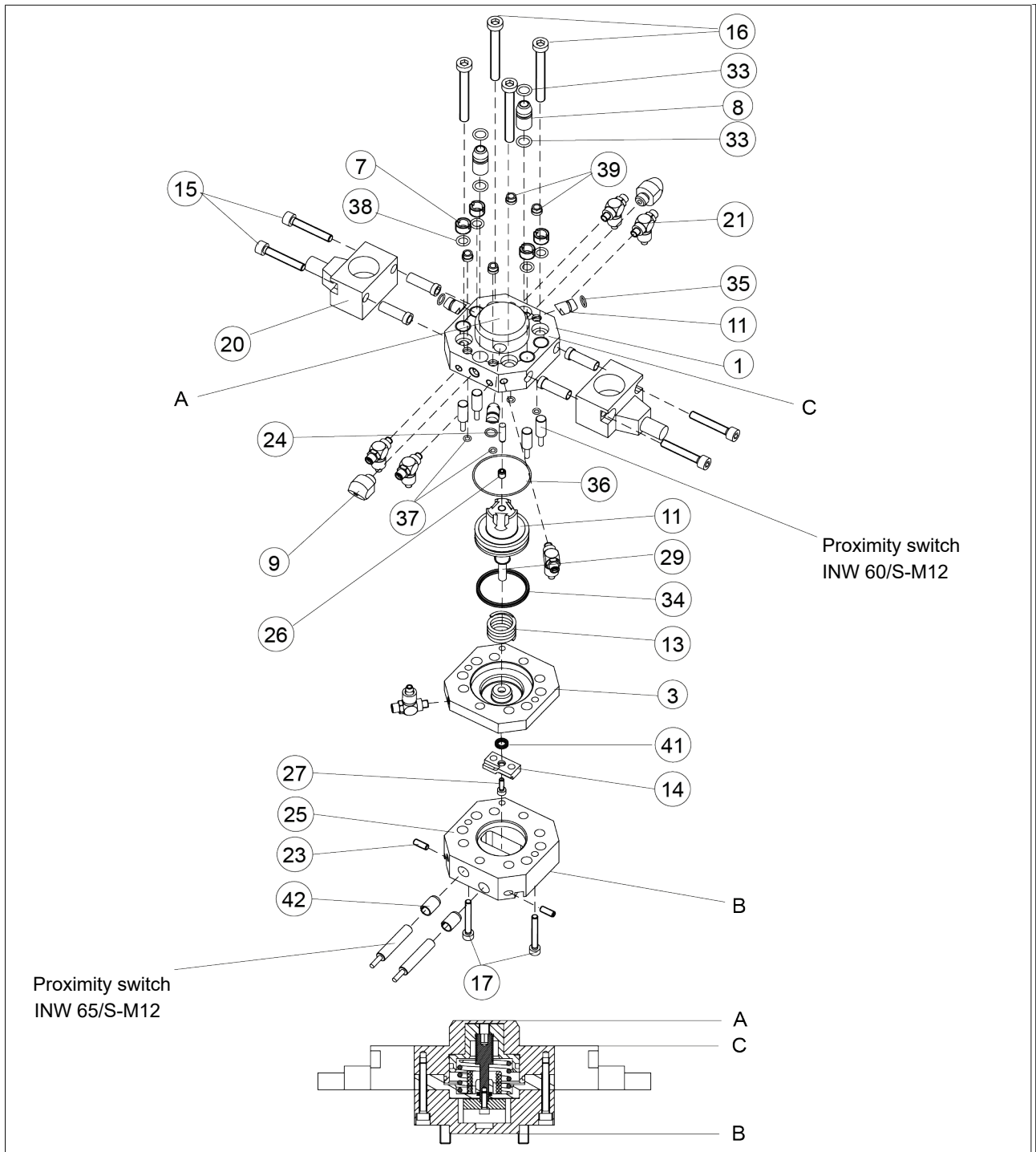

Assembly of GWK-A 64

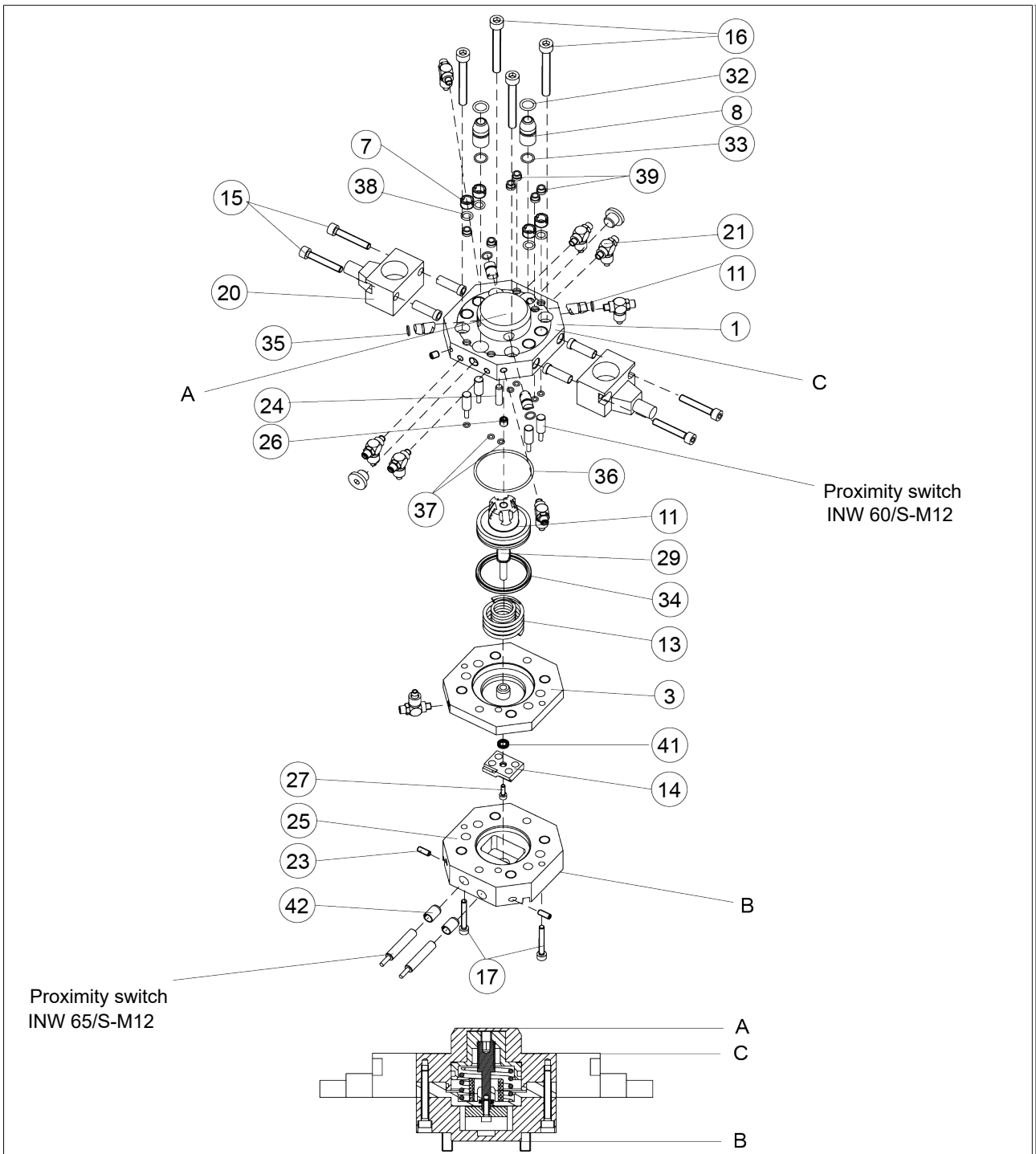

Assembly of GWK-A 80

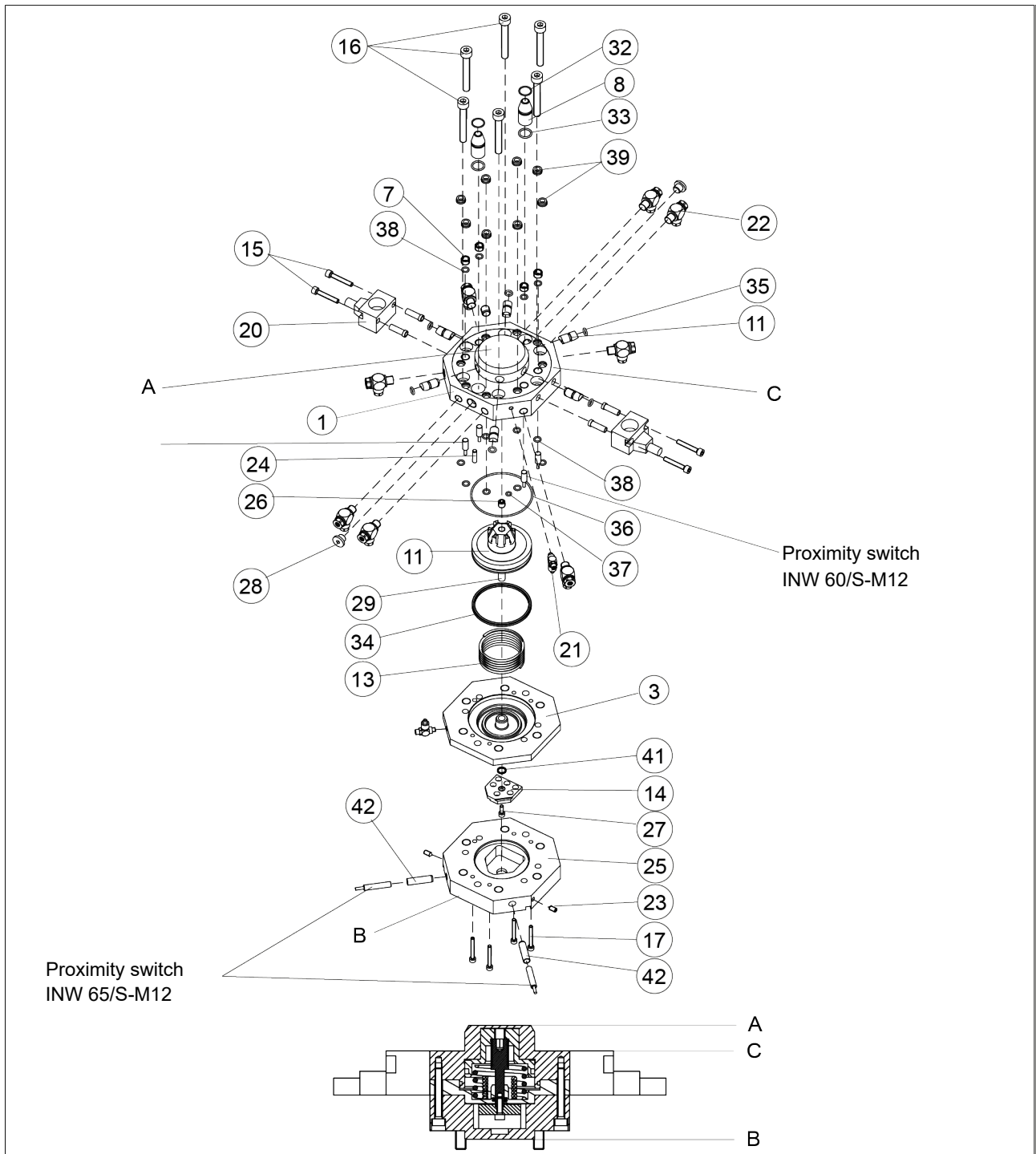

Assembly of GWK-A 125

6 Troubleshooting

Errors	Possible cause / Corrective action
GWK-A does not lock	<ul style="list-style-type: none"> • Check air supply. • Air or control line swapped
GWK-A does not lock properly	<ul style="list-style-type: none"> • Contact surface between GWK-A and GWA is dirty • Joint tolerances exceeded • Connections for plug connector are bent (joint tolerances).
GWK-A does not unlock properly	<ul style="list-style-type: none"> • Guide between piston and clamping pin broken • Unlocking pressure < 4.5 bar
Gripping force gets weaker	<ul style="list-style-type: none"> • Check seals • Check air pressure

7 Translation of the original declaration of incorporation

in terms of the Directive 2006/42/EG, Annex II, Part 1 Section B.

Manufacturer/ Distributor SCHUNK SE & Co. KG
Toolholding and workholding | Gripping technology | Automation
technology
Bahnhofstr. 106 – 134
D-74348 Lauffen/Neckar

We hereby declare that the partly completed machine described below

Product designation: Gripper changing head / GWK-A /pneumatic
ID number 0302506 ... 0302536

meets the following basic occupational health and safety of the Machinery Directive 2006/42/EC:

No. 1.1.1, No. 1.1.2, No. 1.1.3, No. 1.1.5, No. 1.3.2, No. 1.5.3, No. 1.5.4, No. 1.5.6, No. 1.5.8, No. 1.5.10, No. 1.5.11, No. 1.5.13

The partly completed machinery may not be put into operation until it has been confirmed that the machine into which the partly completed machinery is to be installed complies with the provisions of the Machinery Directive (2006/42/EC). The declaration shall be rendered invalid if modifications are made to the product.

Applied harmonized standards, especially:

EN ISO 12100:2010 Safety of machinery – General principles for design –
Risk assessment and risk reduction

The special technical documentation according to Annex VII, Part B, belonging to the partly completed machine, has been created.

Person authorized to compile the technical documentation:
Stefanie Walter, Address: see manufacturer's address

Signature: see original declaration

Lauffen/Neckar, August 2023

Dr.-Ing. Manuel Baumeister,
Head of Systems Engineering,
Technology & Innovation

9 Information on the RoHS Directive, REACH Regulation and Substances of Very High Concern (SVHC)

RoHS Directive

SCHUNK products are classified as "large-scale stationary installations" or as "large-scale stationary industrial tools" within the meaning of Directive 2011/65/EU and its extension 2015/863/EU "on the restriction of the use of certain hazardous substances in electrical and electronic equipment (RoHS)", or fulfill their intended function only as part of one. Therefore products from SCHUNK do not fall within the scope of the directive at this time.

REACH Regulation

Products from SCHUNK fully comply with the regulations of Regulation (EC) No. 1907/2006 "concerning the Registration, Evaluation, Authorization and Restriction of Chemicals (REACH)" and its amendment 2022/477. SCHUNK attaches great importance to completely avoiding chemicals of concern to humans and the environment wherever possible.

Only in rare exceptional cases do SCHUNK products contain SVHC substances on the candidate list with a mass content above 0.1%. In accordance with Article. 33 (1) of Regulation (EC) No. 1907/2006, SCHUNK complies with its duty to "communicate information on substances in articles" and lists the components concerned and the substances used in an overview that can be viewed at [schunk.com\SVHC](https://www.schunk.com/SVHC).

Signature: see original declaration

Lauffen/Neckar, August 2023

Dr.-Ing. Manuel Baumeister,
Head of Systems Engineering,
Technology & Innovation





SCHUNK SE & Co. KG
Toolholding and workholding | Gripping technology |
Automation technology

Bahnhofstr. 106 - 134
D-74348 Lauffen/Neckar
Tel. +49-7133-103-0
Fax +49-7133-103-2399
info@de.schunk.com
schunk.com

Folgen Sie uns | *Follow us*



Wir drucken nachhaltig | *We print sustainable*