



Assembly and Operating Manual

FDB

Radially flexible pneumatic deburring tool

Translation of Original Operating
Manual

Hand in hand for tomorrow

Imprint

Copyright:

This manual is protected by copyright. The author is SCHUNK SE & Co. KG.
All rights reserved.

Technical changes:

We reserve the right to make alterations for the purpose of technical improvement.

Document number: 389072

Version: 06.00 | 20/02/2025 | en

Dear Customer,

Thank you for trusting our products and our family-owned company, the leading technology supplier of robots and production machines.

Our team is always available to answer any questions on this product and other solutions. Ask us questions and challenge us. We will find a solution!

Best regards,

Your SCHUNK team

Customer Management

Tel. +49-7133-103-2503

Fax +49-7133-103-2189

cmg@de.schunk.com



Please read the operating manual in full and keep it close to the product.

Table of Contents

1 General	5
1.1 About this manual.....	5
1.1.1 Presentation of Warning Labels	5
1.1.2 Definition of Terms	6
1.1.3 Symbol definition.....	6
1.1.4 Applicable documents	6
1.1.5 Sizes.....	6
1.2 Warranty	7
1.3 Scope of delivery.....	7
2 Basic safety notes	8
2.1 Intended use.....	8
2.2 Safety Precautions	9
2.3 General Safety Guidelines	10
3 Product Overview	11
3.1 Tool Collet Systems	12
4 Technical Data	13
5 Installation	17
5.1 Inspection of Condition When Delivered	17
5.2 Unpacking and Handling	17
5.3 Mounting	17
5.3.1 Axial Mounting Installation	18
5.4 Pneumatics.....	19
6 Operation	23
6.1 General Precautions.....	23
6.2 Working Environment	24
6.3 Operational Considerations.....	24
6.4 Lock axis for compensation in one direction (FDB 900 / FDB 1040)	24
6.5 Tool Center Point (TCP) Position and Programming	26
6.6 Cutter Operation and Burr Selection.....	28
6.6.1 Burr Selection Table	29
7 Troubleshooting	33
8 Maintenance	35
8.1 Recommended Spare Parts	35
8.2 Preventive Maintenance	36
8.2.1 Inspect Pneumatics Lines and Filter Regulator	36
8.2.2 Lubrication	36
8.2.3 Inspektion des Faltenbalgs der Spindel	37

8.2.4 Burr Inspection	37
8.3 Service Procedures	37
8.3.1 Burr Replacement	37
8.3.2 Air Motor Replacement	39
8.3.3 Pivot Bearing Replacement.....	48
8.3.4 Ring Cylinder Assembly Replacement	52
8.3.5 Spindle Boot Replacement FDB 660	55
9 Transport and storage	57
9.1 Transportation and Protection during Transportation	57
9.2 Storage and Preventive Maintenance during Storage.....	57
10 Translation of the original declaration of incorporation	58
11 UKCA declaration of incorporation	59
12 Information on the RoHS Directive, REACH Regulation and Substances of Very High Concern (SVHC)	60

1 General

1.1 About this manual

This manual contains important information for a safe and appropriate use of the product.

This manual is an integral part of the product and must be kept accessible for the personnel at all times.

Before starting work, the personnel must have read and understood this operating manual. Prerequisite for safe working is the observance of all safety instructions in this manual.

In addition to these instructions, the documents listed under ▶ 1.1.4 [6] are applicable.

NOTE: The illustrations in this manual are intended to provide a basic understanding and may deviate from the actual version.

1.1.1 Presentation of Warning Labels

To make risks clear, the following signal words and symbols are used for safety notes.



⚠ DANGER

Dangers for persons!

Non-observance will inevitably cause irreversible injury or death.



⚠ WARNING

Dangers for persons!

Non-observance can lead to irreversible injury and even death.



⚠ CAUTION

Dangers for persons!

Non-observance can cause minor injuries.

NOTICE

Material damage!

Information about avoiding material damage.

1.1.2 Definition of Terms

The term "product" replaces the product name on the title page in this manual.

1.1.3 Symbol definition

The following symbols are used in this manual:

■ Prerequisite for an action

1. Action 1

2. Action 2

⇒ Intermediate results

⇒ Final results

▶ 1.1.3 [📄 6]: chapter number and [page number] in hyperlinks

1.1.4 Applicable documents

- General terms of business *
- Catalog data sheet of the purchased product *

The documents labeled with an asterisk (*) can be downloaded from [schunk.com/downloads](https://www.schunk.com/downloads).

1.1.5 Sizes

This operating manual applies to the following sizes:

- FDB 150
- FDB 300
- FDB 340
- FDB 900
- FDB 1040

1.2 Warranty

Die Gewährleistung für die Radially flexible pneumatic deburring tool FDB beträgt 24 Monate. Der Luftmotor ist hiervon ausgenommen.

Die Gewährleistung des Luftmotors beträgt 1000 Betriebsstunden bei ölfreiem Betrieb oder 12 Monate ab Lieferdatum Werk; maßgeblich ist das früher eintretende Ereignis.

Werkstückberührende Teile und Verschleißteile sind nicht Bestandteil der Gewährleistung.

1.3 Scope of delivery

The scope of delivery includes

- Radially flexible pneumatic deburring tool FDB in the version ordered
- Safety information (product-specific instructions available online)
- Accessory kit

Contents of the accessory kit:

FDB-150

- 1x wrench (1/4")
- 1x wrench (9/32")
- 4x M3x12 screw (for fixing the axle)

FDB-300 & FDB-340 in all variants

- 1x wrench (7/16")
- 1x wrench (9/16")

FDB 900 & FDB-1040

- 1x wrench (7/16")
- 1x wrench (ER11, Rego)

2 Basic safety notes

2.1 Intended use

The product is to be used only for the deburring of workpieces.

The product is intended for installation on a robot. The requirements of the applicable guidelines must be observed and complied with.

- The product may only be used within the scope of its technical data, ▶ 4 [13].
- The product is intended for industrial and industry-oriented use.
- Appropriate use of the product includes compliance with all instructions in this manual.

Use which is not specified as an intended use is for instance when

- the product is used with machines/systems or workpieces that are not designed to be used with the unit.
- the product is operated without protective equipment in accordance to the EC Machinery Directive.
- the statutory safety and accident-prevention regulations and the standards and guidelines valid at the usage site are not observed.

2.2 Safety Precautions



⚠ WARNING

High sound levels can occur during cutting.

Failure to wear hearing protect can cause hearing impairment.

- Never operate the FDB product without wearing hearing protection.
- Always use hearing protection while working in the neighborhood of the deburring tool.



⚠ WARNING

Flying debris can cause injury.

- Always use eye protection while working in the neighborhood of the deburring tool.
- Never operate the FDB product without wearing eye protection.



⚠ CAUTION

Using burrs rated for less than the speed of the FDB being used may cause injury or damage equipment.

- Do not use burrs rated for less than the speed of the FDB being used.
- Always use burrs rated for at least the speed of the FDB being used.



⚠ WARNING

Use of spare parts not supplied by SCHUNK can damage equipment and void the warranty.

- Do not use spare parts other than original SCHUNK spare parts.
- Always use original SCHUNK spare parts.



⚠ WARNING

Flying debris and rotating parts can cause injury.

- Never be present near the deburring tool while it is started or in operation.
- If it is necessary to approach the deburring tool while in motion, stand behind appropriate Plexiglas windows.
- Provide a barrier to prohibit people from approaching the deburring tool while in operation must secure the installation.



⚠ WARNING

Injury or equipment damage can occur with tool not docked and air on.

- Do not perform maintenance or repair on the FDB product unless the tool is safely supported or docked in the tool stand and air has been turned off.
- Dock the tool safely in the tool stand and turn off the air before performing maintenance or repair on the FDB product.

2.3 General Safety Guidelines

Prior to purchase, installation, and operation of the FDB, the customer should first read and understand the operating procedures and information described in this manual. Never use the deburring tool for any purposes, or in any ways, not explicitly described in this manual. Follow installation instructions and pneumatic connections as described in this manual.

All pneumatic fittings and tubing must be capable of withstanding the repetitive motions of the application without failing. The routing of pneumatic lines must minimize the possibility of stress/strain, kinking, rupture, etc. Failure of critical pneumatic lines to function properly may result in equipment damage.

3 Product Overview

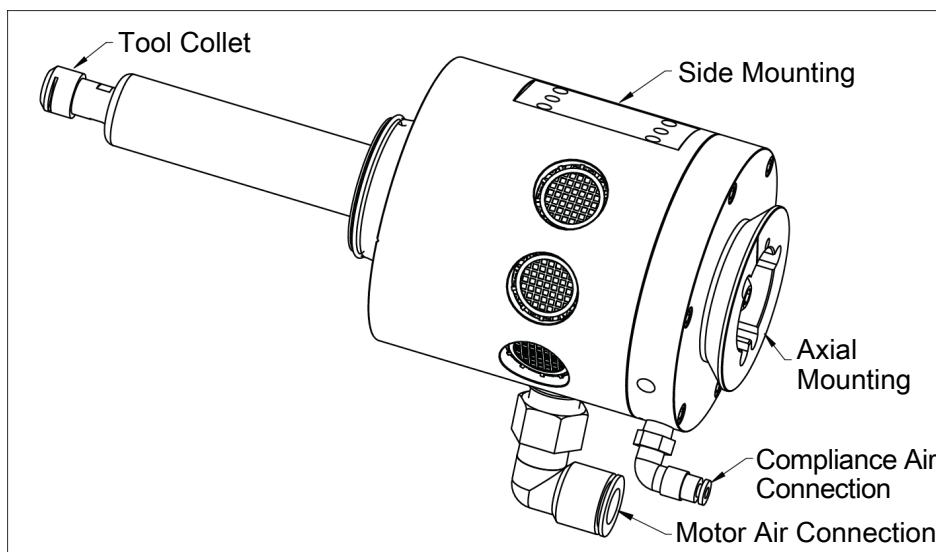

FDB Deburring Tool

The FDB Deburring Spindle is a robust, high-speed and lightweight air turbine-driven deburring unit for deburring aluminum, plastic, steel, etc. with a robot or CNC machine. The FDB is especially suited for removal of parting lines and flash from parts. However, its flexible design allows it to be used in a wide variety of applications.

The FDB's pneumatically controlled, articulated design allows the cutting bit to follow the part profile and compensate for surface irregularities while maintaining a constant, settable force. This allows high feed rates with uniform quality in any orientation. The tool also requires no oil, allowing clean exhaust air to be vented directly into the work environment.

Compliance is supported by air pressure applied to the shaft of the unit and is used to perform consistent deburring on irregular part patterns. The motor's internal governor maintains high spindle speeds for optimum surface finish. The FDB also utilizes standard industrial tungsten-carbide bits which allows for adaptation to changing assembly lines and part requirements.

The FDB provides for two mounting types, a side mounting and an axial mounting. The axial mounting utilizes a tapered flange that requires an adapter plate. Custom adapter plates for both side and axial mounting are available from SCHUNK.

A tool collet system secures the burr and many collet sizes and of tools are available to accommodate a wide variety of applications.

3.1 Tool Collet Systems

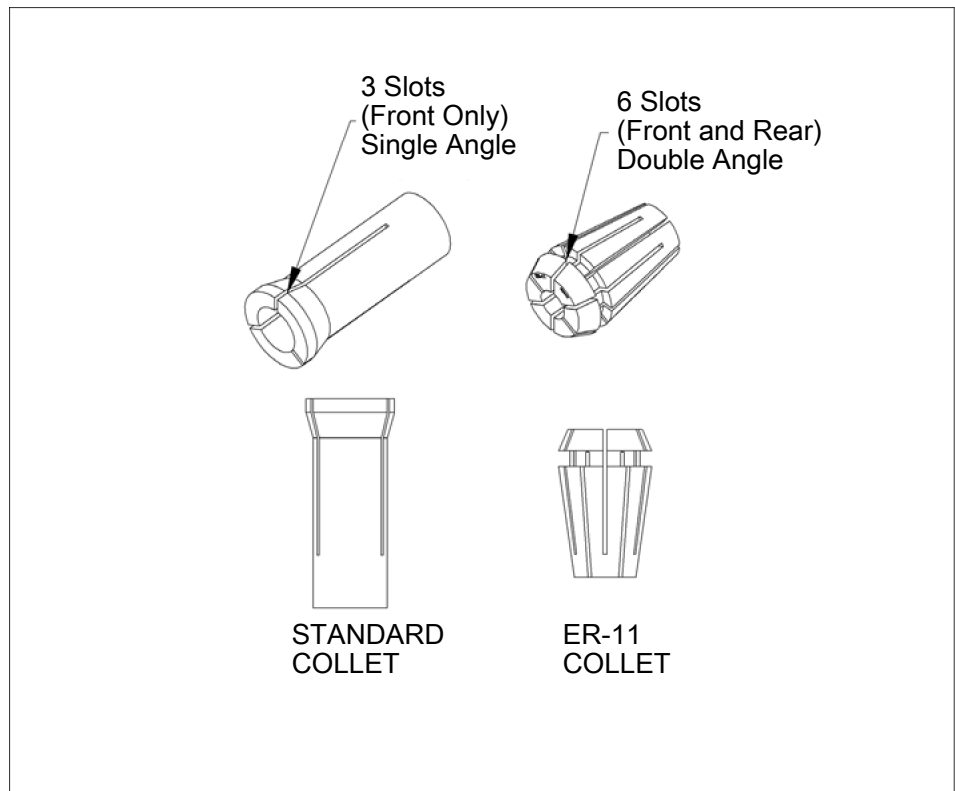

Tool Collets

All FDB products utilize removable collets to secure customer supplied cutting tools. Different collet diameters may be substituted to retain numerous cutter shank diameters. The collet retaining nut is loosened to open the collet allowing cutting tools to be removed and inserted. Once the tool is set to the desired depth, spanner wrenches are used to tighten the collet nut causing the collet to collapse and secure the cutting tool. The air motor design does not allow the installation of spindle brakes or quick-change (drawbar) collet systems.

4 Technical Data

Tab.: Environmental restrictions

Operation:

Installation position:	Mount on the robot with the lateral mounting hole pattern or the rear adapter flange. The flange varies from robot to robot. This optional flange is usually supplied by SCHUNK as a blank, which the customer can adapt according to their requirements. Mount on a table or bracket using an adapter plate (the workpiece is fed in by the robot).
------------------------	---

Temperature range:	5° C – 35° C
--------------------	--------------

Storage:

Temperature range:	5° C – 35° C
--------------------	--------------

Storage conditions:	Store the product in packaging in a dry place. If available, store the product in its delivery packaging ► 9.2 [□ 57].
---------------------	--

Equipment:	The product requires clean, dry, filtered, oil-free compressed air. The use of coalescing filters and filter elements with a nominal value of 5 microns or finer is required. The spindle must be supplied with 6.2 – 6.5 bar. The radial flexibility (centered) must be supplied from a regulated source at 1.0 to 1.4 bar.
------------	--

Tab.: Technical Specifications

	FDB		
	150	300	340
Motor		Compressed air turbine	
Idle speed [RPM]	65,000	30,000	40,000
Power	150 W (0.20 hp) at 65,000 RPM	300 W (0.40 hp) at 30,000 RPM	340 W (0.46 hp) at 40,000 RPM
Weight (without adapter)	1.1 kg	1.2 kg	1.2 kg
Compensation range (radial)	±6.4 mm max. radial, ±3.2 mm recommended	±7.5 mm max., ±3 mm recommended	±7.5 mm max., ±3 mm recommended
Deflection force (measured at the collet)	0.9 – 5.8 N, at 1 – 4.14 bar	12.7 – 42 N at 1.0 – 4.1 bar	12.7 – 42 N at 1.0 – 4.1 bar
Deburring speed	Depending on the geometry of the grinder and the motor speed		
Spindle air pressure	6.2 bar maximum	6.2 – 6.5 bar [6.9 bar max]	6.2 – 6.5 bar [6.9 bar max]
Air consumption (idle)	1.42 l/s (3 CFM)	5.6 l/s (6 CFM)	5.6 l/s (6 CFM)
Air consumption (blocked)	3.78 l/s (8 CFM)	10.2 l/s (21.5 CFM)	10.2 l/s (21.5 CFM)
Noise pressure level *	78 dB(A) (without milling cutter)	78 dB(A) (without milling cutter)	78 dB(A) (without milling cutter)

	FDB		
	150	300	340
Collet diameter (standard)**	3 mm	6 mm	6 mm
Milling cutter ***	Special tools (included in scope of delivery)	commercial units classified for 40,000 RPM or higher	commercial units classified for 40,000 RPM or higher
Special tools	Wrenches, 6.4 mm and 7 mm	Wrenches (1 pair included in scope of delivery) 14.5 mm, 11 mm	Wrenches (1 pair included in scope of delivery) 14.5 mm, 11 mm

Tab.: Technical Specifications

	FDB	
	900	1040
Motor	Compressed air turbine	
Idle speed [RPM]	25,000	40,000
Power	900 W at 25,000 RPM	1000 W at 40,000 RPM
Weight (without adapter)	approx. 3.4 kg	approx. 3.45 kg
Compensation range (radial)	±9 mm max. radial, ±5 mm recommended	
Deflection force (measured at the collet)	12.8 – 45.4 N at 1.0 – 4.1 bar	
Deburring speed	Depending on the geometry of the grinder and the motor speed	
Spindle air pressure	6.2 – 6.5 bar 6.9 bar max	
Air consumption (idle)	11.8 l/s (25 CFM)	
Air consumption (blocked)	19 l/s (40 CFM)	
Noise pressure level *	78 dB(A) (without milling cutter)	
Collet diameter (standard)**	6 mm (ER-11)	
Milling cutter ***	commercial units classified for 40,000 RPM or higher	
Special tools	Wrenches (1 pair included in scope of delivery) 11 mm, unlimited 10 mm, narrow (only for ER11 collets)	

* All noise emission measurements were taken under no load idle conditions without a cutting tool. Because the working environment is unknown it is impossible to predict the noise that will occur during a deburring operation. The FDB may also excite resonant frequencies on equipment to which it is mounted creating higher sound pressure levels than the unit by itself.

- ** Optional sizes available, ▶ 8.1 [35]
- ** SCHUNK can supply Burrs, ▶ 6.6.1 [29]

Each FDB deburring tool receives a thorough test procedure before it is shipped.

The following chart shows measured forces relative to applied compliance (centering) air pressure. Measurements may vary from one product to another, and should only be treated as nominal.

FDB 150

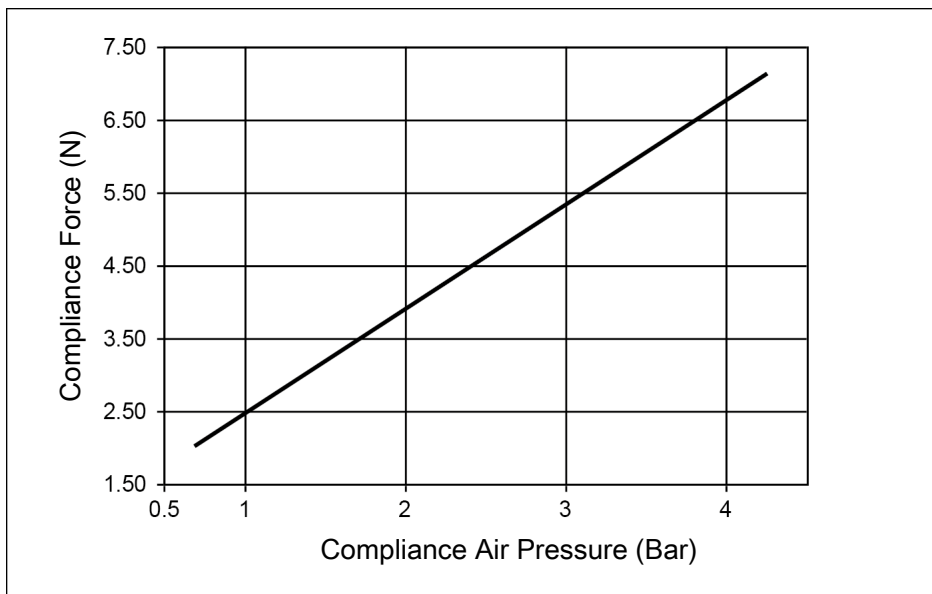

FDB 300/340

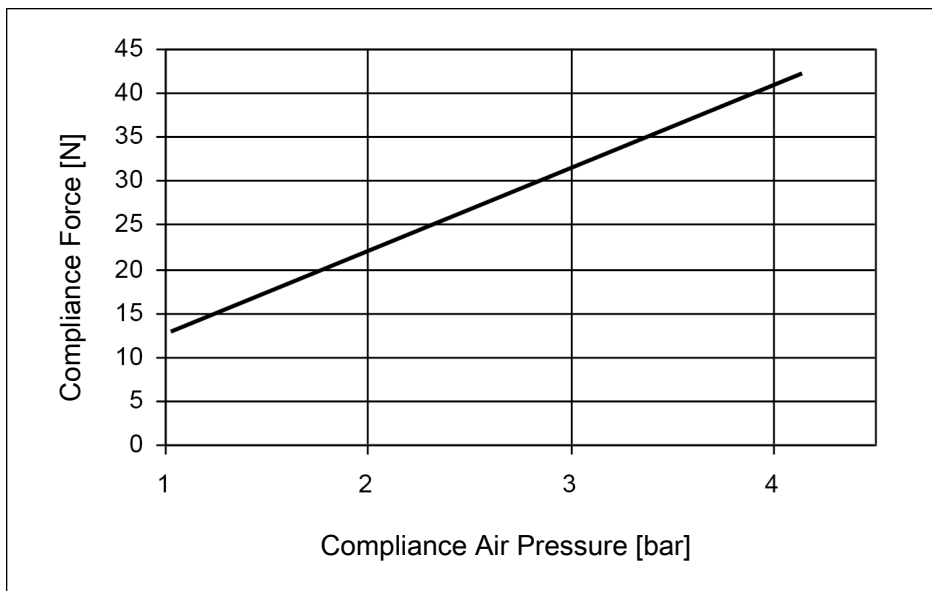

FDB 900/1040

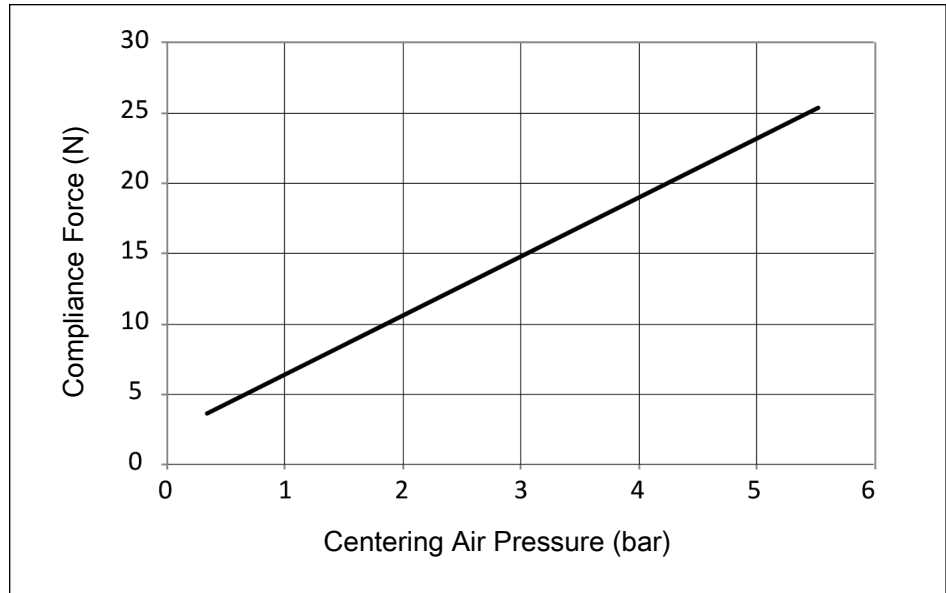

The actual force characteristics will vary slightly from installation to installation due to mounting orientation and condition of the unit. The air turbine will attempt to maintain its full rated speed even under loaded conditions. However, when extremely heavy cuts are taken the motor may eventually stall. Therefore, multiple light passes are preferred over slow, heavy cuts.

5 Installation

The FDB Deburring Spindle is delivered fully assembled. Optional equipment such as: mounting adapter plates, burrs, and additional collets will be separate.

5.1 Inspection of Condition When Delivered

Upon receipt, the following should be checked:

- Delivery in accordance with freight document
- Damage to packaging
- If there is damage to any of the packaging, or if any of the goods have been exposed to abnormal handling, unpack those parts that may have been damaged for a closer inspection. If necessary, notify SCHUNK for assistance in evaluation of the product condition.

5.2 Unpacking and Handling

The FDB Deburring Spindle should always be placed inside the accompanying box (crate) during transportation, storing and handling.

Pneumatic lines and electrical cables are attached, bundled, and must be strain-relieved in a manner that allows for freedom of movement during operation.

5.3 Mounting

The FDB is capable of rear (axial) or side (radial) mounting. SCHUNK offers a blank rear interface plate kit for rear mounting and a simple foot bracket for bench mounting.

NOTICE

When using the side mounting pattern, the mounting screws must not exceed maximum depth from the mounting surface into the housing.

If screws extend past the maximum depth, they can interfere with the free compliance of the tool. Use proper length screws with the side mounting pattern, refer to the catalogue for further details of the mounting features and requirements.

The FDB must be rigidly mounted using either of its mounting surfaces prior to use. Under no circumstances should the unit be used for manual/hand deburring. Once securely mounted, the unit should be supplied with clean, dry, non-lubricated air filtered 5 micron or better. The use of a coalescing air filter is recommended to remove all trace moisture and oil.

Air line fittings supplying the FDB should be installed with care using a minimum of tape or liquid sealant. To prevent contaminant damage to the air motor, all air lines should be blown down to remove debris prior to connection of the FDB.

NOTICE

The FDB must be supplied with clean, dry, non-lubricated air filtered five micron or better. The use of a coalescing filter is recommended.

Water and oil damage of the air motor or damage associated with the debris in the air lines is not covered under warranty.

5.3.1 Axial Mounting Installation

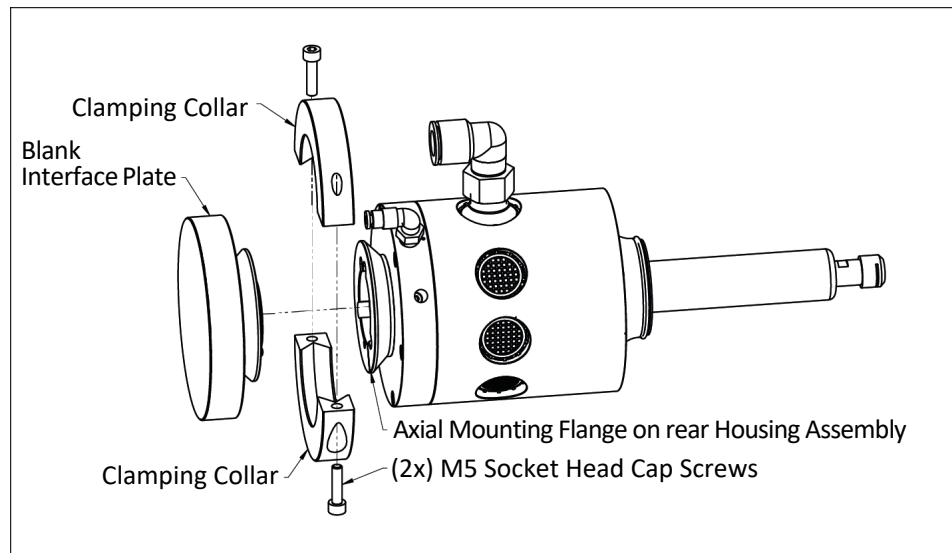

Axial Installation

A blank robot adapter plate is also available to allow axial mounting off the rear of the deburring tool housing. This plate may be modified by the system integrator or by the owner/user of the FDB. SCHUINK can provide custom interface plates and adapters upon request. An optional bench mount adapter plate allows the FDB to be permanently attached to a bench or other work surface. If the FDB is permanently mounted to a work surface, the robot carries the part to be deburred to the FDB.

5.4 Pneumatics

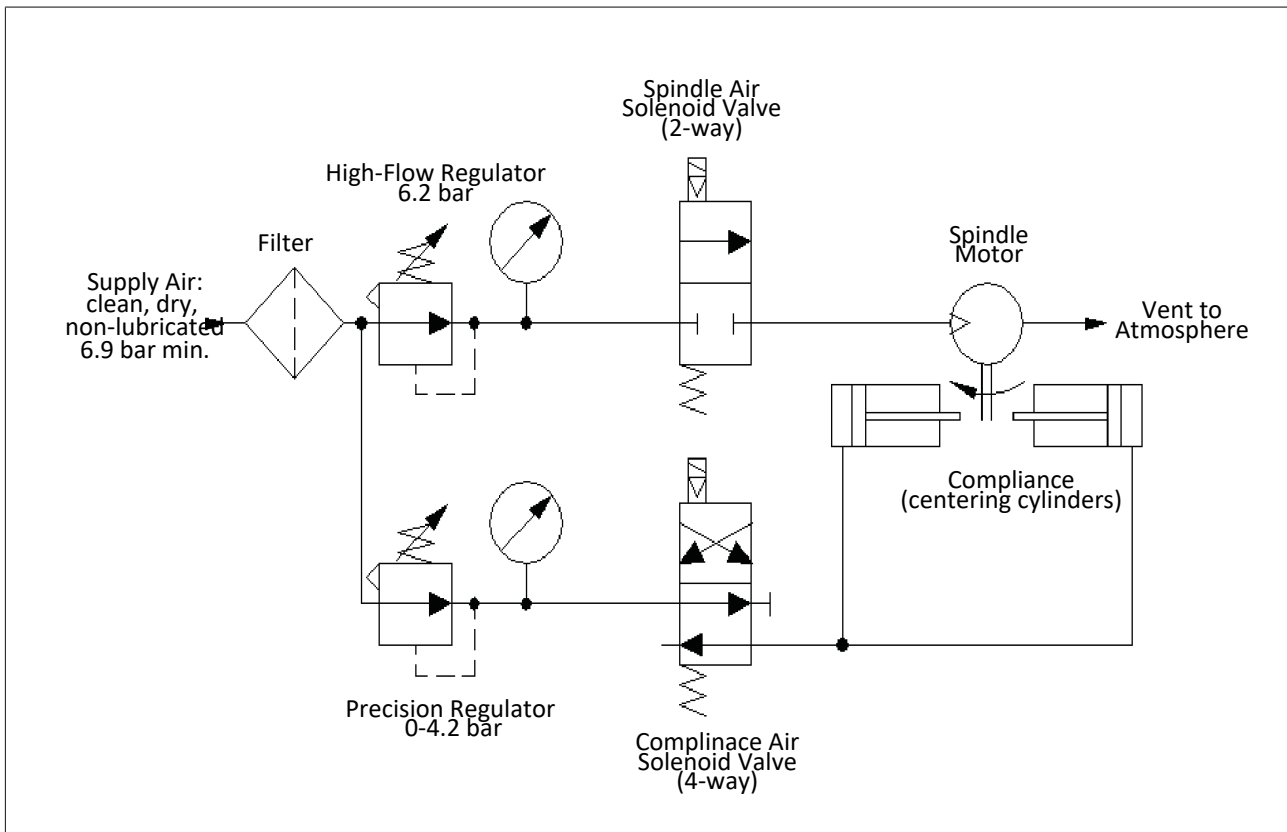

Pneumatic connections FDB-150 and FDB-300/-340

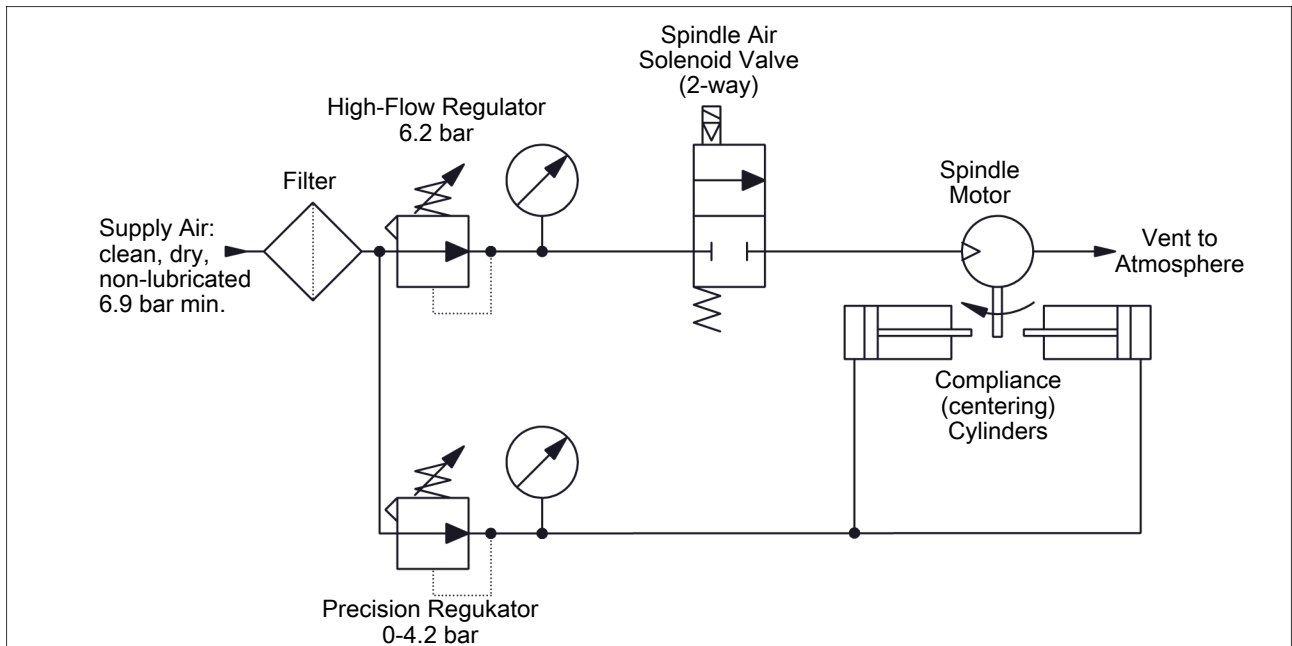

Pneumatic connections FDB-900 and FDB-1040

NOTICE

All pneumatic fittings and tubing must be capable of withstanding the repetitive motions of the application without failing. The routing of pneumatic lines must minimize the possibility of over stressing, pullout, or kinking the lines.

Failure to do so can cause some critical pneumatic lines not to function properly and may result in damage to equipment.

The air supply should be dry, filtered, and free of oil. A coalescing filter with elements rated for 5 micron or better is required.

A high-flow air pressure control regulator is required to supply the spindle motor . A second, precision, self-relieving regulator will supply air for the compliance or centering force.

The compliance force is applied radially and is adjusted until the desired cut is made. The robot traversing speed will also be adjusted to achieve the desired finish.

NOTICE

Pneumatic components used for the motor drive circuit must be capable of meeting the air consumption requirements ▶ 4 [13].

Poor performance will result if the correct components are not used.

Conventional, customer-supplied, pneumatic components are used to control the air supply to the deburring tool. SCHUNK recommends that the user install a high-flow pneumatic pressure regulator and a high-flow valve to properly supply a stable air supply to the spindle motor ▶ 4 [13] for the maximum flow requirement. The FDB will not operate properly if supplied air is below 6.2 bar.

A second, precision, self-relieving regulator is used to supply the compliance (centering) mechanism. This pressure corresponds to the side force on the rotary burr. Very little airflow is required for the compliance mechanism.

If the complete workpiece can be deburred with equal force, a conventional, manual pressure regulator can be used for compliance. If the burrs to be removed vary from place to place on the work piece, and this variation is repeatable for all work pieces of the same type, it may be necessary to adjust the force using an analog pressure regulator controlled from the robot. An analog output port in the robot or logic controller will be needed.

Solenoid valves are actuated from the robot or program logic controller by means of a digital output signal.

Function	Connection type	Pressure
Motor inlet		
FDB 150	1/8" NPT connection	6.2 bar
FDB 300 FDB 340	3/8" quick connector hose Alternative: Remove the supplied SCHUNK connection in order to use the 1/8 NPT connection (or use the 5/16 [8 mm] hose adapter)	6.2 – 6.5 bar
FDB 900 FDB 1040	12 mm Alternative: Remove the supplied SCHUNK connection in order to use the 3/8 NPT connection in the motor body, or use the 12 mm to 10 mm hose adapter	6.2 – 6.5 bar
Inlet for compensation force (radial)		
FDB 150	1/8" NPT connection	1.4 – 4.2 bar (maximum)
FDB 300 FDB 340 FDB 900 FDB 1040	5/32" (4 mm) hose Alternative: Remove the supplied connection in order to use the 1/8" NPT connection	1.4 – 4.1 bar (maximum)
Exhaust air	Emitted to the environment via the housing.	N/A

Tab.: Pneumatic connections

It is recommended that flexible plastic tubing be used for the motor air supply and the compliance force air supply. The installed fittings can be removed to expose tapped supply ports thus allowing the use of alternate, customer-supplied components. The turbine air motor is extremely quiet and vents dry air to the environment through the screen-covered ports on the side of the housing. No mufflers are required. Information on the sound intensity is provided in ▶ 4 [□ 13]. To reduce the sound from the cutting operation in neighboring working areas, a customer-supplied barrier surrounding the installation may be installed (Plexiglas® or Lexan™ is preferred, ▶ 4 [□ 13]).

The compliance force, air supply pressure regulator should have a (FDB 150: 1.4 – 4.2 bar / FDB 300–1040: 0–4.1 bar) range. When testing for the proper contact force, start with a very low pressure and increase slowly until the desired cut is achieved.

6 Operation

These operating instructions are intended to help system integrators program, start up, and complete a robotic deburring cell containing a deburring tool and a deburring installation containing a FDB deburring spindle. The system integrator should be familiar with the task of deburring in general and should have extensive knowledge of programming and automation.

6.1 General Precautions

It is important that all personnel involved in operation of the FDB have a thorough understanding of the operating procedures. Failure to follow these or neglecting safety precautions can create hazardous situations which may, in the worst case, injure personnel or damage the deburring installation and the FDB.



! DANGER

Never use the FDB as a hand-held machine or for purposes other than robotic or automated deburring.

If used in any other way, serious injury or damage to equipment may occur.

Countersinking and other axial metal-forming processes should not be performed by the FDB. It may be dangerous to operate the FDB deburring tool for these purposes. If a failure occurs due to forces caused by improper use, hazardous situations for both personnel and equipment could be created. The FDB is intended to perform deburring only.

The FDB should not be used to deburr materials that are prone to fracture. A fracturing workpiece may result in pieces of material damaging surrounding working environment and personnel. Material removed correctly should be in the form of chips.

Reduce the feed rate when the work piece and the FDB are making initial contact. Making the contact movement between the deburring tool and the work piece too fast may in some situations result in a collision. Collisions may create hazardous situations for both personnel and equipment.

When performing maintenance, always remember to tighten nuts and bolts. When replacing burrs, always be sure to attach the burr correctly. Please consult ▶ 8.3 [37]



! DANGER

- Never use the FDB in a manner to produce axial loads.
- Never use the FDB for countersinking or drilling.

6.2 Working Environment

As described in previous sections the FDB should only be used in an automated cell/chamber.

The work cell must be secured by means of barriers to prohibit personnel from entering the cell. A lockable door should be included as a part of the barrier in order to facilitate access to the cell for authorized personnel only. The barrier could consist partly or fully of Plexiglas to facilitate observation of the deburring operations.

During system or FDB maintenance, make sure the FDB and robot are stopped before entering the robot cell. When installing and testing, never be present in the cell when the FDB is running.

Be aware of rotating parts. Use eye-protection while working around the FDB.

Be aware of high sound levels. While the FDB air motor is not loud, the cutting action associated with deburring frequently is. Always use hearing protection while working in the neighborhood of the deburring cell.

6.3 Operational Considerations

For instructions on how to replace the burr, please consult ▶ 8.3 [37].

In many robotic deburring applications, including steel and aluminum, no cooling or lubrication of the rotary burr is necessary. For some materials and situations, the addition of coolants or compressed air may aid the cutting process. If it is determined that liquid coolants are required, a non-oil, cutting type should be used to prevent premature wear of the spindle bearing.

Burr selection is discussed in ▶ 6.6.1 [29].

6.4 Lock axis for compensation in one direction (FDB 900 / FDB 1040)

The deburring spindle has an axis lock function to limit the compensation path to the X axis. For this purpose, 4 hexagon socket cheese-head screws M4 x 16 are included in the scope of delivery.



⚠ CAUTION

Screws of unsuitable length for the locking axis can cause damage.

The deburring spindle can get damaged. Personal injury may result due to a malfunction.

- only use M4 x 16 mm hexagon socket screws to lock the axis.

- Required tools:
2.5 mm and 3 mm hexagon socket wrench, torque wrench
 - Materials required:
Loctite 7649 primer and Loctite 222
1. Remove the compressed air hose.

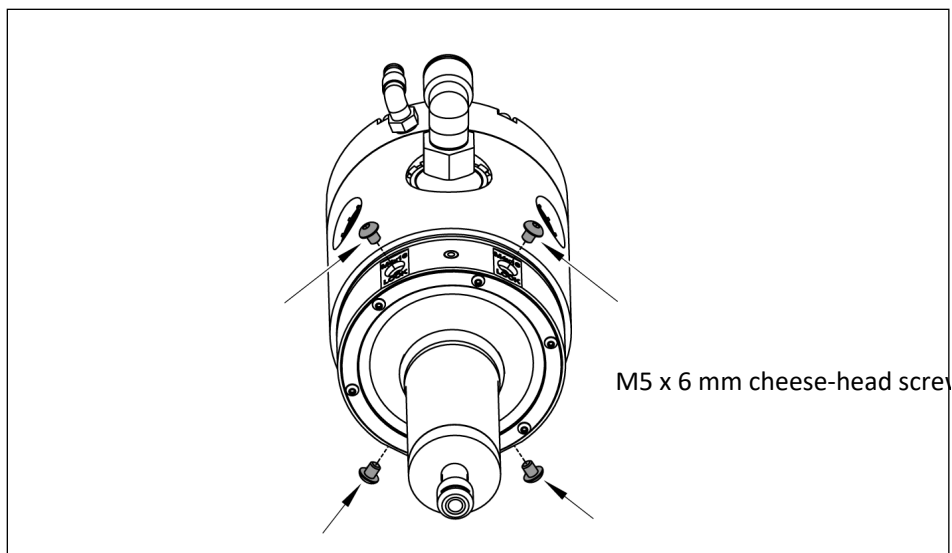

Remove screws

2. Remove the 4 hexagon socket screws M5 x 6 mm from the housing.

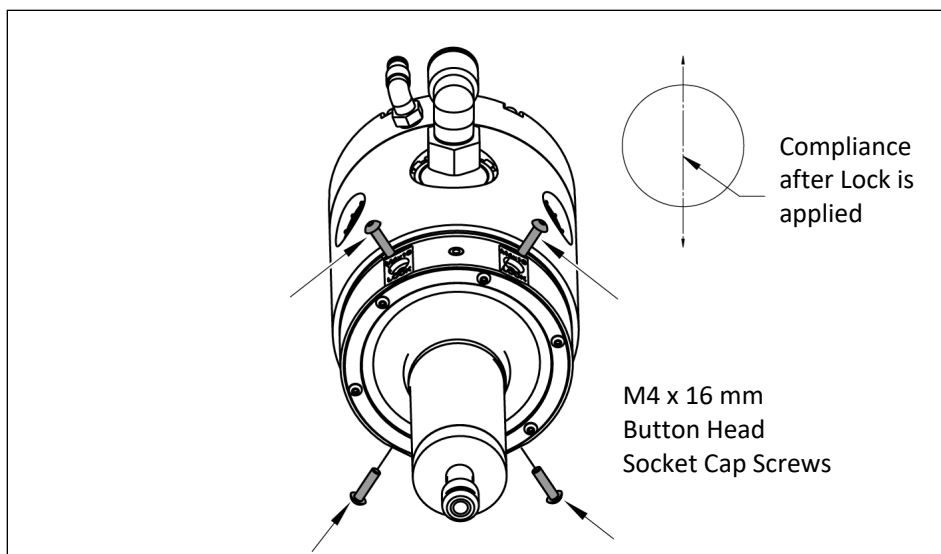

3. Apply Loctite 7649 primer and Loctite 222 to the 4 hexagon socket screws M4 x 16 mm.
4. Using a 2.5 mm hexagon socket wrench, insert the 4 hexagon socket screws M4 x 16 mm into the threads on the housing from which the 4 hexagon socket screws M5 x 6 mm were removed.
Tighten the screws to 2.82 Nm.
5. Connect all compressed air lines.

6.5 Tool Center Point (TCP) Position and Programming

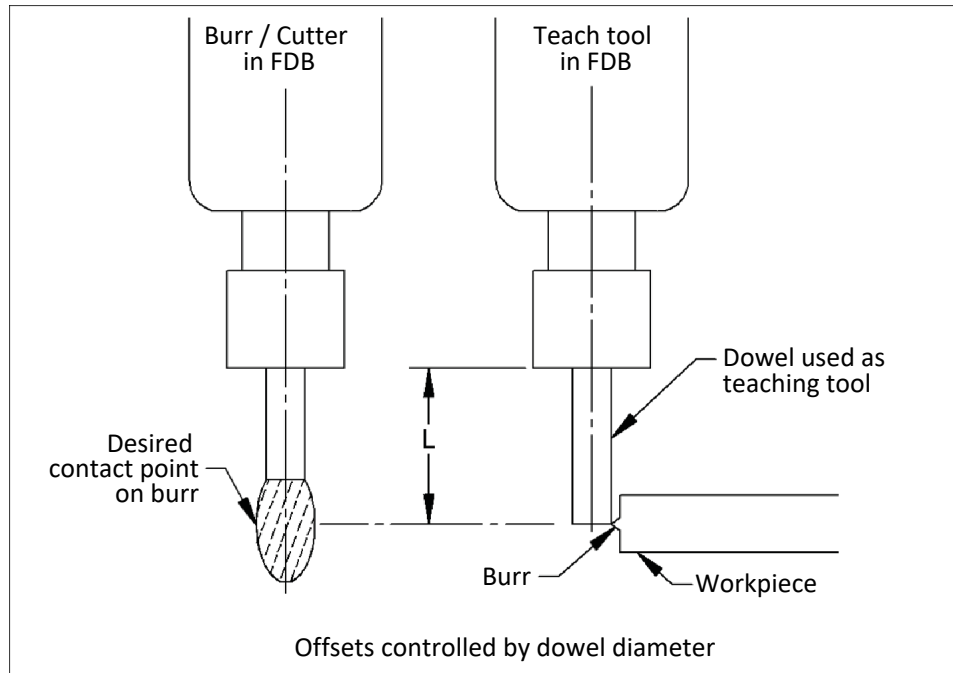

FDB Dowel Teaching Tool

The Figure shows the FDB dimensions. The FDB provides radial compliance and performs best when the cuts taken are not excessively deep. The Deburring spindle must never be running while programming a machining center or the robot. During teaching, the compliance air must be on and supplied above a minimum of 1.4 bar (FDB-150) or 0.35 bar (FDB-300/-340/660/990/1040).

Two programming methods are suggested but others are possible. In the first method, a dowel pin of suitable diameter is inserted in place of a cutting tool (simulating the cutter shank diameter) when teaching the robot path. For 6mm (1/8") collets, this will mean a 6mm (1/8") diameter pin of suitable length. The dowel pin should extend sufficiently from the collet to reach the surface on the burr where cutting is desired. The diameter of the cutter should not exceed that of the dowel pin by more than the compliance range of the FDB.

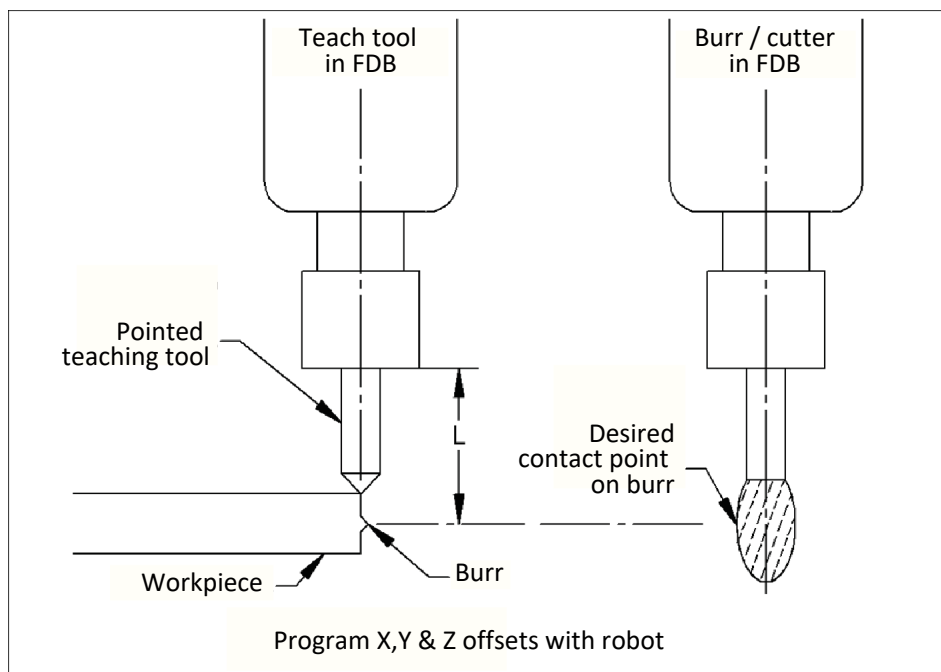

FDB Pointed Teaching Tool

Another programming method is to teach the path using the centerline of the burr as a guide, following the edge of the part, and then manually or automatically adding offsets to the robot path to achieve the final correct burr path (see Figure). The programming method used will depend on the machining center's or robot's capabilities and programmer preferences.

Inside corners represent a complex situation for compliant deburring spindles. In general, the cutter must not be allowed to simultaneously contact both perpendicular surfaces of an inside corner. The resulting force imbalance in two planes will cause severe tool chatter. The customer is advised to create a tool path, which will prevent the cutter from simultaneously contacting two perpendicular surfaces. A tapered cutter may reach further into such an inside corner if the tool is presented in an inclined orientation and closer to the tip of the tool. (Note: When working near the tip of a tapered cutter the surface cutting speed is reduced.)

When deburring inside radii, a similar situation may arise. The customer is advised that no attempt should be made to deburr an inside radius less than 1.5 times the diameter of the desired cutter ($R_{min} = 1.5 \times \text{Cutter diameter}$). Depending on the depth of cut, failing to follow these guidelines may result in excessive cutter contact resulting in excessive tool chatter.

When running the program the first time, observe the path with the radial compliance air supply turned down to approximately 1.4 bar (FBD-150) or 0.35 bar (FDB-300/-340/-660/990/1040).

When the robot path speed is increased, it is important to notice

that robot may deviate from the programmed path. Verify that at operational robot path speed, the burr is deflected but contacts the work surface. Once the robot path has been confirmed, the compliance force of the burr should be adjusted ▶ 5.4 [D 19], in order to achieve a correct depth of cut.

6.6 Cutter Operation and Burr Selection

The FDB will perform best in “climb milling”. This refers to a cutter whose directions of traverse and cutter rotation are the same. In the case of the FDB, the cutter rotation is clockwise when viewed from above. Climb milling would therefore involve clockwise motion around the outside of a part being deburred. In climb milling, the heaviest cut is made as the tool enters the workpiece and the chip becomes narrower as the cut is completed. In “conventional milling”, the cutter travels in a direction opposite of cutter rotation. This may aid in cutter stability for some operations, however, the cutting edge of the tool is subjected to higher friction and cutting forces. Tool wear is accelerated in this mode and surface finish quality will generally be reduced. When “conventional milling”, extra care must be taken around corners. This poses a potential hazard where the cutting force can deflect the burr causing the burr to break as the machine/robot continues along its path.

The selection of a cutting tool is highly dependent upon the part material and geometry, and the depth of cut. It is not practical to present all the possibilities in this document. Please see ▶ 6.6.1 [D 29] of this document for a short list of burrs and suitable applications. It is worth mentioning here that a specific family of burrs is available for working with die cast alloys, aluminum, and plastics. These cutters have fewer teeth and increased relief to minimize chip loading.

Plastics represent the most difficult deburring challenge due to the phenomenon of chip re-welding. In this process, if the cutter is dull or the feeds and speeds are not correct for the material removed, chip will melt and weld to the cutter or the work piece. This can quickly load a cutter and produce unacceptable results. In general, the traverse or feed rate of the FDB will be higher for plastics to minimize this behavior. This results in larger cuts, which more effectively remove heat from the cutter-tool interface.

6.6.1 Burr Selection Table

Standard length commercial burrs are used with FDB products. The length of these tools is typically around 2 inches for 1/4" shank diameter burrs [50mm for 6mm diameter]. Longer shank burrs are available from industrial suppliers and will appear in their catalogs with descriptions such as "long" or "extended" shank. Their use is to be avoided. Using extended or long shank burrs in the FDB will place higher loads and vibrations on the motor bearings resulting in reduced motor life. Bearing failure caused by the use of extended shank burrs is not covered under warranty.



⚠ CAUTION



Long shank tools can lead to premature failure of the air motor and is not covered under warranty.



- DO NOT use long or extended shank burrs with the FDB.
- Use standard length commercial burrs with the FDB.

SCHUNK can provide guidance in burr selection, however, only experimentation will yield the results desired. The following table is presented to assist in burr selection.



This following table is not comprehensive, but includes many common burr types and burrs recommended for particular applications.





Tab.: Burr Selection FDB-150

	Materials/Application:	Features/Benefits:
	Double Cut, Straight, 1/8" Burr Diameter, 9/16" Burr Length, 1/8" Shank <ul style="list-style-type: none"> • For hardened and tough materials, super alloys, and stainless steel, alloyed cast steel and fiber reinforced plastics • Edge and surface working • Built up Welds of high-tensile strength in mold and die making 	<ul style="list-style-type: none"> • Higher cutting capacity than standard cuts • Smoother finish for surface treatments
	Double Cut, 14° Cone, 1/8" Burr Diameter, 7/16" Burr Length, 1/8" Shank <ul style="list-style-type: none"> • For hardened and tough materials, super alloys, and stainless steel, alloyed cast steel and fiber reinforced plastics • Edge and surface working 	<ul style="list-style-type: none"> • Higher cutting capacity than standard cuts • Smoother finish for surface treatments

	Materials/Application:	Features/Benefits:
	<p>Fiberglass Router, Straight, 1/8" Burr Diameter, 1/2" Burr Length, 1/8" Shank</p> <ul style="list-style-type: none"> • For trimming and contour milling of all glass and carbon fiber reinforced plastics 	<ul style="list-style-type: none"> • Special cut geometry allows high feed rates due to low cutting forces
	<p>Double Cut, Flame, 1/8" Burr Dia., 1/4" Burr Length, 1/8" Shank</p> <ul style="list-style-type: none"> • Universal use, for ferrous and non-ferrous metals, plastics • Rough finishing of castings • Surface working. • Weld removal. • Brazed welds. 	<ul style="list-style-type: none"> • Smoother operation, improved tool control • High cutting action • Non-clogging • Smaller chips, reduced slivers • Even, smooth surfaces

Tab.: Burr Selection FDB 300 – 1040

	Materials/Application	Features/Benefits:
	<p>Diamond Cut, 1/4" Burr Diameter, 5/8" Burr Length, 1/4" Shank</p> <ul style="list-style-type: none"> • For hardened and tough materials, super alloys, and stainless. steel, alloyed cast steel and fiber reinforced plastics. • Edge and surface working. • Built up Welds of high-tensile strength in mold and die making. 	<ul style="list-style-type: none"> • Higher cutting capacity than standard cuts. • Smoother finish for surface treatments. • Lower axial force than ADC.
	<p>Standard Cut, 3/8" Burr Diameter, 3/4" Burr Length, 1/4" Shank</p> <ul style="list-style-type: none"> • For steels of high tensile strength die steels, cast steel, built up welds, tough materials, and welds. • For beveling. • For chamfering. • For deburring. 	<ul style="list-style-type: none"> • Without chip breaker, for scratch-free surfaces.

Materials/Application	Features/Benefits:
 <p data-bbox="304 248 1150 286">Diamond Cut, 3/8" Burr Diameter, 3/4" Burr Length, 1/4" Shank</p> <ul data-bbox="304 300 1353 689" style="list-style-type: none"> • For hardened and tough materials, super alloys, and stainless steel, alloyed cast steel and fiber reinforced plastics. • Edge and surface working. • Built up Welds of high-tensile strength in mold and die making. • Higher cutting capacity than standard cuts. 	<ul data-bbox="911 300 1353 427" style="list-style-type: none"> • Smoother finish for surface treatments. • Lower axial force than ADC.
 <p data-bbox="304 705 1171 743">Aluminum Cut, 3/8" Burr Diameter, 5/8" Burr Length, 1/4" Shank</p> <ul data-bbox="304 757 823 981" style="list-style-type: none"> • For greasy aluminum alloys, soft non-ferrous metals and thermoplastics. • For deburring. • For use on cast aluminum. 	<ul data-bbox="911 757 1414 1108" style="list-style-type: none"> • Easy chip flow through positive rake angle, rounded base of tooth, convex tooth back. • No loading of the flutes, not even while cutting sticky metals. • Smooth operation due to the peeling effect of the teeth.
 <p data-bbox="304 1122 1171 1160">Aluminum Cut, 3/8" Burr Diameter, 5/8" Burr Length, 1/4" Shank</p> <ul data-bbox="304 1173 823 1397" style="list-style-type: none"> • For greasy aluminum alloys, soft non-ferrous metals and thermoplastics. • For deburring. • For use on cast aluminum. 	<ul data-bbox="911 1173 1422 1525" style="list-style-type: none"> • Easy chip flow-through positive rake angle, rounded base of tooth, convex tooth back. • No loading of the flutes, not even while cutting sticky metals. • Smooth operation due to the peeling effect of the teeth.
 <p data-bbox="304 1538 1070 1576">Cut FVK, 1/4" Burr Diameter, 5/8" Burr Length, 1/4" Shank</p> <ul data-bbox="304 1590 1361 1718" style="list-style-type: none"> • For trimming and contour milling of all glass and carbon fiber reinforced plastics. 	<ul data-bbox="911 1590 1361 1718" style="list-style-type: none"> • Special cut geometry allows high feed rates due to low cutting forces.

Materials/Application	Features/Benefits:
 <p data-bbox="304 248 1118 286">Alt Diamond Cut, 1/4" Burr Dia., 3/4" Burr Length, 1/4" Shank</p> <ul data-bbox="304 300 863 580" style="list-style-type: none"><li data-bbox="304 300 863 378">• Universal use, for ferrous and non-ferrous metals, plastics.<li data-bbox="304 392 751 430">• Rough finishing of castings.<li data-bbox="304 443 592 481">• Surface working.<li data-bbox="304 495 560 533">• Weld removal.<li data-bbox="304 546 552 584">• Brazed welds.	<ul data-bbox="911 300 1406 580" style="list-style-type: none"><li data-bbox="911 300 1406 378">• Smoother operation, improved tool control.<li data-bbox="911 392 1246 430">• High cutting action.<li data-bbox="911 443 1166 481">• Non-clogging.<li data-bbox="911 495 1398 533">• Smaller chips, reduced slivers.<li data-bbox="911 546 1294 584">• Even, smooth surfaces.

7 Troubleshooting

Deburring process development is an iterative, learning task. The following table is presented to assist in solving deburring problems.

Symptom	Cause	Resolution
Burr Wear	Hard work material	Use better grade burr material add coating (TiAlN)
	Too heavy a cut	Decrease width of cut/make multiple passes
	Feed rate is too slow	Increase feed rate
Burr Breakage	Too heavy a cut	Decrease width of cut/make multiple passes
	Deflection at corner	Climb mill/do not begin path at sharp corner
	Impacting part	Decrease feed rate at contact/ enter part at an angle
Unequal compliance	Pivot bearing worn	Replace pivot bearing, ▶ 8.3.3 [48]
	Compliance preload screw not set properly	▶ 8.3.3 [48] for proper adjustment.
	Worn ring cylinder	Replace ring cylinder, ▶ 8.3.4 [52]
Poor finish on work piece	Feed rate is too fast	Reduce feed rate
	Burr is worn	Inspect burr if worn, replace. ▶ 8.3 [37]
	Motor bearings are worn	Inspect spindle shaft, if shaft feels loose or has play, replace. ▶ 8.3.2 [39].
Burr Chattering during cut	Feed rate is too fast	Reduce feed rate
	Lack of rigidity	Increase radial compliance pressure
	Too heavy a cut	Decrease width of cut/make multiple passes
	Improper Burr selection	Choose burr designed for work material
	Burr is worn	Inspect burr if worn, replace ▶ 8.3 [37].
	Motor bearings are worn	Inspect spindle shaft, if shaft feels loose or has play, replace. ▶ 8.3.3 [48].
Secondary Burrs created on work piece after cut	Incorrect feed rate	Reduce feed rate
	Too heavy a cut	Decrease width of cut/make multiple passes
	Improper Burr selection	Choose burr designed for work material
	Burr is worn	Inspect burr if worn, replace ▶ 8.3 [37].
	Motor bearings are worn	Inspect spindle shaft, if shaft feels loose or has play, replace. ▶ 8.3.3 [48].

Symptom	Cause	Resolution
Chip Packing of Burr	Too heavy a cut	Decrease width of cut/make multiple passes
	Not enough chip clearance	Use a burr with less flutes
Burr stalls	Not enough or no drive air	Check drive air regulator for 6.2 Bar and for leaks
	Burr is not secure in collet	Properly tighten burr in collet
	Too much side load	Decrease width of cut/make multiple passes
	Air motor needs replacing	Replace air motor ▶ 8.3.2 [39] .
Sticking spindle	Motor bearings are worn	Replace air motor ▶ 8.3.2 [39] .

8 Maintenance

The user is encouraged to return the unit to SCHUNK for maintenance. ▶ 7 [33] is provided to assist the user when they choose to maintenance the FDB in the field. For all maintenance, it is recommended that the air supply (before the solenoid valves) be disconnected. Drain any trapped air pressure in the lines. It is suggested that the air supply be "locked out" to prevent accidental operation of the spindle. During maintenance operations, refer to ▶ 8.3 [37] Procedures for maintenance instructions. Service and repair parts are identified in Serviceable Parts.

8.1 Recommended Spare Parts

For repair and spare parts please contact SCHUNK. Suggested user replaceable, optional and spare parts are listed in the tables below. All other repairs must be performed by SCHUNK:

Available spare parts

1/8" collet

3 mm collet

Clamping nut

Replacement motor

Tab.: FDB-150

Ø 3 mm collet

Ø 1/8" collet

Ø 3/16" collet

Ø 6 mm collet

Ø 1/4" collet

Clamping nut, FDB 300/ FDB 340 motor (.450 Lg. x .318 hole)

Clamping nut, FDB 300/ FDB 340 motor (.450 Lg. x .254 hole)

Spindle hose adapter, 3/8 to 5/16" [8 mm]

Spindle hose adapter, 1/2" to 5/16" [8 mm]

Replacement motor

Tab.: FDB-300/-340

Ø 4 mm ER-11 collet

Ø 6 mm 1/4" ER-11 collet

Clamping nut, ER collet

Replacement motor

Tab.: FDB-900/1040

Recommended parts for stocking

SCHUNK recommends stocking the following spare parts:

Collar

Replacement motor

1/4" – 9/32" (6.35 – 7.1 mm) double open-ended wrench

Tab.: FDB-150

FDB 300/ FDB 340 series, flat collar

Replacement motor

7/16" [11 mm] open-end wrench

9/16" [14.5 mm] open-end wrench

Tab.: FDB-300/-340

8.2 Preventive Maintenance

The FDB is designed to provide a long life with few parts requiring regular maintenance. The preventive maintenance of the deburring tool consists of cleaning the unit and regular inspection for wear or damage of the pneumatic lines, filter element, spindle boot, and burr. Refer to ► 7 [□ 33] and Service Procedures to assist the user when they choose to service the unit in the field.

8.2.1 Inspect Pneumatics Lines and Filter Regulator

The air lines to the FDB should routinely be checked for their general condition and replaced as required. The air to the FDB must be filtered, dry, and non-lubricated. The air filters should be checked and replaced as required to maintain optimum performance. The life of the filter elements is dependent on the quality of compressed air at the customer's facility and therefore cannot be estimated.

8.2.2 Lubrication

Lubrication systems are not to be used. The FDB air motor must be supplied with clean, dry, filtered air. Oil in the air stream will cause the air motor to fail prematurely. Failure of the motor due to oil in the air stream is not covered under the warranty. See ► 5.4 [□ 19] for details on air supply and quality.

NOTICE

Oil in the air stream will result in the premature failure of the air motor and is not covered under warranty.

It is recommended that the customer use a coalescing filter and filter elements rated 5 micron or better.

- DO NOT use lubricated air with the FDB

8.2.2.1 Pneumatics

The air tubing/lines to the FDB should routinely be checked for their general condition and replaced as required. The air to the FDB must be filtered, dry, and non-lubricated. The air filters should be checked and replaced as required to maintain optimum performance. The life of the filter elements is dependent on the quality of compressed air at the customer's facility and therefore cannot be estimated.

8.2.3 Inspektion des Faltenbalgs der Spindel

The bellows of the spindle prevent dirt from entering the housing and protects internal components. Check the bellows regularly for damage and replace if necessary.

8.2.4 Burr Inspection

The burr will wear depending on cut depth, feed rate and material being deburred. Inspect the burr regularly for wear and refer to ▶ 7 [📄 33] for symptoms of worn burr.

8.3 Service Procedures

8.3.1 Burr Replacement

In normal operation, the burr will become worn. If improper feeds and speeds are used, the cutter may become loaded with material. In both instances, the cutter will need to be replaced. During initial production, the burr and the workpiece should be examined often in order to determine at what interval the burr should be replaced.

Replacing the collet will not be required when the burr is replaced but may be required when a different sized tool is required. Collet replacement is included in the following chapters.

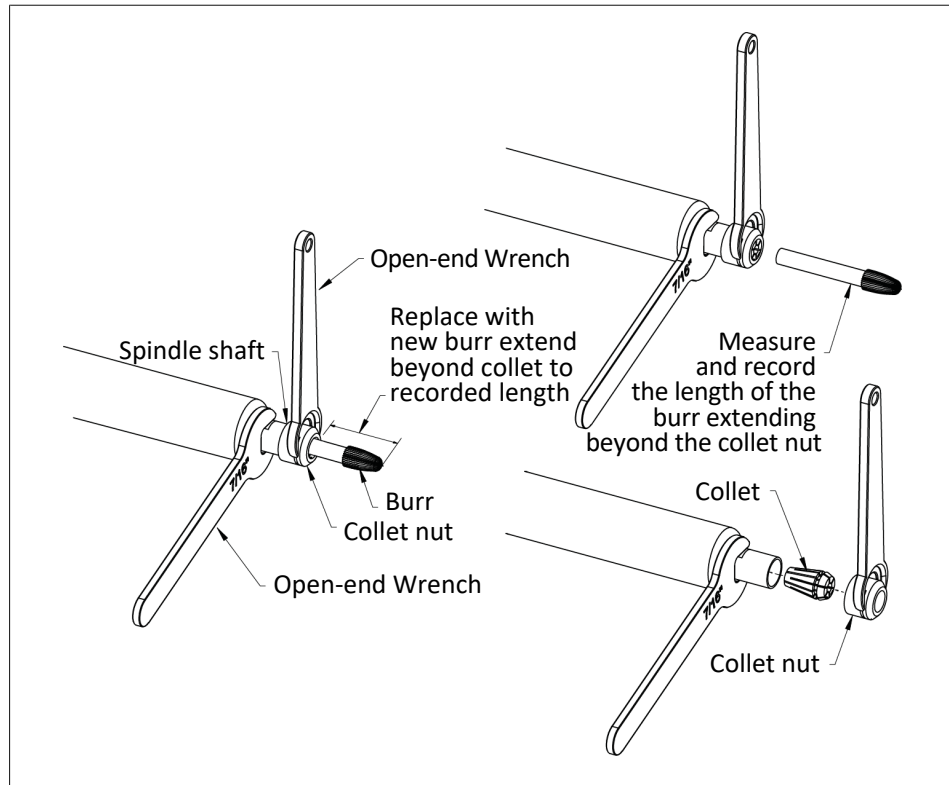

1. Remove and/or lock-out the spindle motor air supply for safety.
2. If the burr is to be replaced with one of an identical type, measure and record the burr length extending beyond the collet lock nut.
3. Use the one of the open-end wrenches to hold the spindle just behind the collet nut.
4. Use the second wrench to turn the collet locknut counterclockwise (when viewed from the burr tip) to loosen the collet.
5. To remove a worn burr, pull the burr out of the loosened collet.
6. If the collet is being replaced, completely remove the nut and extract the old collet. Insert the new collet and refit the nut leaving it loose
7. If an identical new burr is replacing a worn one, insert the new burr and measure and adjust the length of its exposed portion according to the measurement taken in the first step.
8. Tighten the collet by reversing the steps above.
9. Restore the air supply.

8.3.2 Air Motor Replacement

If the air motor is operated using oil laden air, it will fail and require replacement. Failure of the motor due to oil in the spindle air is not covered under warranty. The motor may also require replacement after an extended operating life. There are no user-serviceable parts in the air motor. FDB units with defective motors should be returned to SCHUNK during the warranty period.

The air motor is replaced as a subassembly. Should the customer wish to replace the motor subassembly after the warranty period, the steps in the following chapters must be performed:

8.3.2.1 Air Motor Replacement FDB 150

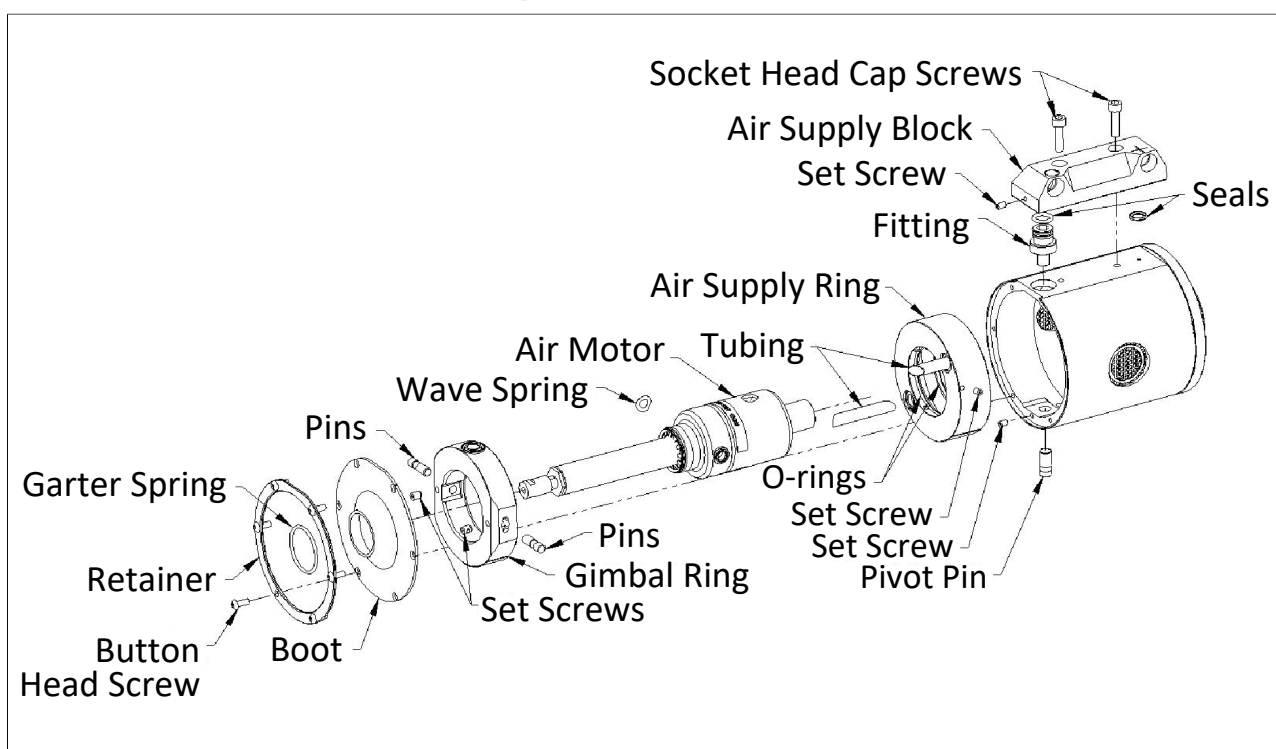

1. Remove and/or lock-out the spindle motor air supply for safety.
2. Disconnect the air hose from the spindle supply fitting and the compliance air fitting.
3. Remove the deburring tool from the robot or work location.
4. Clean the debris from the deburring tool using compressed air and a clean rag to wipe any grease from the outer surfaces.
5. Ease the garter spring off the front spindle boot.
6. Remove the button head screws and retainer securing the boot to the front of the unit.
7. Remove the boot.

8. On the air supply block, remove the small set screw visible below/near the spindle air supply port.
9. Remove the two socket head screws securing the air supply block to the side of the unit.
10. Remove the air supply block. Retain all seals and fasteners for reuse.
11. Remove the fitting exposed when the air block is removed by turning it counterclockwise.
12. Remove the small set screw in the front face of the housing.
13. Use needle-nose pliers to remove the pivot pin that secures the gimbal ring in the housing.
14. Move the air motor spindle sideways in the housing toward where the fitting was removed in the previous step and pull the motor assembly from the unit.
15. Loosen the three small set screws from the air supply ring around the back of the motor.
16. Pull the air supply ring to the rear off the motor.
17. Remove the two pieces of tubing from the gimbal ring.
18. Locate the two small set screws in the gimbal ring and remove them.
19. Use needle-nose pliers to remove the pins that were secured by the set screws removed in the previous step.
20. Pull the motor assembly out of the gimbal ring being careful not to loose the wave spring.

Reassembly:

21. Coat the wave spring with light grease and place it on the shoulder inside the gimbal ring prior to sliding the motor assembly in place. The grease will hold the spring in position during this step.
Slide the motor assembly into the gimbal ring making sure that the wave spring remains in place, then press the two pins into the gimbal ring and into the bearing on the motor. Note: The undercut band on the pins must be oriented to the outside, refer to the figure. The pins should be pressed in flush with the flat surfaces on the gimbal ring.
22. Insert the two set screws into the gimbal ring that secure the pin and tighten (torque to 0.67 Nm).
23. Lubricate the OD of the two pieces of metal tubing that go between the outer gimbal ring and the air supply ring prior to their installation, then fit them to the gimbal ring.

- 24.** Lubricate the o-rings on the inside bore of the air supply ring.
- 25.** Locate and align the axial scribe marks on the gimbal ring and the air supply ring then slide the air supply ring down the motor body. The metal tubes from step 23 will enter the seals on the inner face of the air supply ring. Stop when there is a gap of 0.449" (11.4 mm) between the air ring and the gimbal ring measured at the pivot pins in the gimbal ring then tighten the three set screws securing the air ring to the motor body (torque to 0.67 Nm).
- 26.** Slide the motor assembly into the housing. Move the air motor spindle sideways in the housing toward the flat for the air supply block. Continue to slide the motor assembly into the housing until the bearing (without the extended inner race) in the gimbal ring aligns with the threaded hole on the housing flat surface.
- 27.** Press the pivot pin through the housing and into the gimbal ring bearing (with the extended inner race). Note: The undercut band on the pin must be oriented to the outside, refer to the figure. The pin should be pressed in flush with outside diameter of the housing.
- 28.** Install the small set screw in the front face of the housing to secure the pivot pin, torque to 0.67 Nm.
- 29.** Lubricate the seal on the air supply fitting then thread the fitting into the flat of the housing such that it enters the bearing in the gimbal ring without the extended inner race.
- 30.** Tighten the fitting to 0.28 Nm then loosen the fitting by 1/6 turn (1 flat of the hex key).
- 31.** Lubricate and insert the seal that goes into the counterbore of the air supply block, then fit the air supply block to the flat of the housing.
- 32.** Apply Loctite 7649 Primer® and Loctite 222® to the threads of the two socket head cap screws that secure the air supply block to the housing.
- 33.** Secure air supply block to the housing with the two socket head cap screws and torque to 2.8 Nm.
- 34.** Apply Loctite 222 to the thread on the small set screw for the air supply block.
- 35.** Install the small set screw in the hole visible below/near the spindle air supply port on the air supply block (torque to 0.67 Nm).

36. Fit the boot to the front of the housing aligning the holes in the boot and housing.
37. Apply Loctite 7649 Primer® and Loctite 222® to the threads of the six button head screws.
38. Install the retainer to the front of the housing and secure with the button head screws (tighten to contact plus ½ turn).
39. Stretch the center of the boot slightly to fit the collar on the motor, then install the garter spring from the front boot.

8.3.2.2 Air motor Replacement FDB 300 / FDB 340

1. Remove and/or lock-out the spindle motor air supply for safety.
2. Disconnect the air hose from the spindle supply fitting and the compliance air fitting.
3. Remove the deburring tool from the robot or work location.
4. Clean the debris from the deburring tool using compressed air and a clean rag to wipe any grease from the outer surfaces.
5. Remove the brass plug or hex socket screw from the center of the deburring unit's rear plate.
6. Remove the spindle air supply fitting from the side of the housing by rotating it counter-clockwise.
7. Ease the garter spring off the front spindle boot.
8. Remove the socket head cap screws that secure the rear housing cover.
9. Remove the rear cover and withdraw the air motor complete as an assembly. Retain the small o-ring and dowel pin located between the cover and housing for reuse. Motors are available from SCHUNK as a complete subassembly. Refer to ► 8.1 [□ 35] for part numbers.
10. Reassembly is the reversal of these steps noting the following important steps.
 - ⇒ Insure that the small o-ring and dowel pin are in place on the housing before fitting the rear cover.
 - ⇒ Apply light-weight, liquid thread locker (Loctite™ 222 or equivalent) to the socket head cap screws and tighten to secure the rear cover.
 - ⇒ Install the spindle air supply fitting in the air motor using non-hardening thread sealant.
 - ⇒ Insure that the spindle air supply fitting is centered in the housing (side boot) opening before tightening the fastener in the pivot post.

8.3.2.3 Air Motor Replacement FDB 990 / FDB 1040

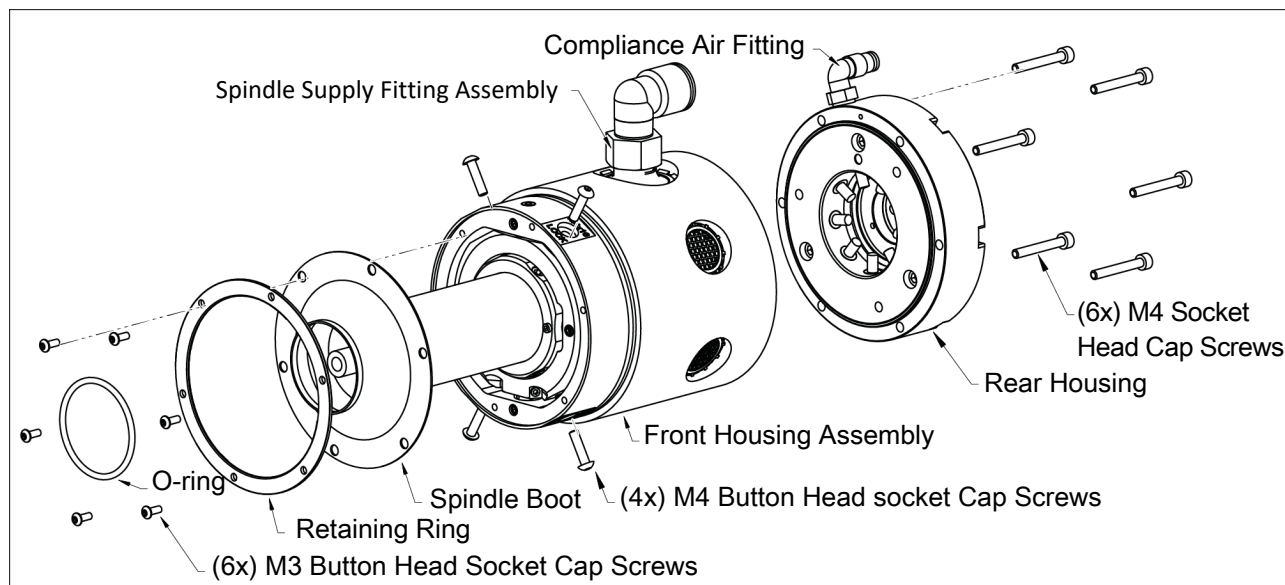

1. Remove and/or lock-out the spindle motor air supply for safety.
2. Disconnect the air hose from the spindle supply fitting and the compliance air fitting.
3. Remove the deburring tool from the robot or work location.
4. Clean the debris from the deburring tool using compressed air and a clean rag to wipe any grease from the outer surfaces.
5. Remove the spindle air supply fitting from the side of the main housing by rotating the fitting counter-clockwise.
6. Using a small screw driver, remove the internal retaining ring and rubber boot. SCHUNK recommends replacing the internal retaining ring and rubber disk at the spindle supply fitting when the motor is replaced.
7. Ease the O-ring off the front spindle boot.
8. Using a 2.5 mm Allen wrench, remove 6 M3 button head socket cap screws holding the boot retainer ring and disk boot to the front housing assembly.
9. Remove the boot retainer ring and disk boot.
10. Using a 2 mm Allen wrench, remove the 6 M4 socket head cap screws that secure the rear housing.
11. Remove the rear housing.
12. If the tool is locked to single axis compliance, use a 2 mm Allen Wrench to remove the 4 M4 x 16 mm button head socket cap screws.

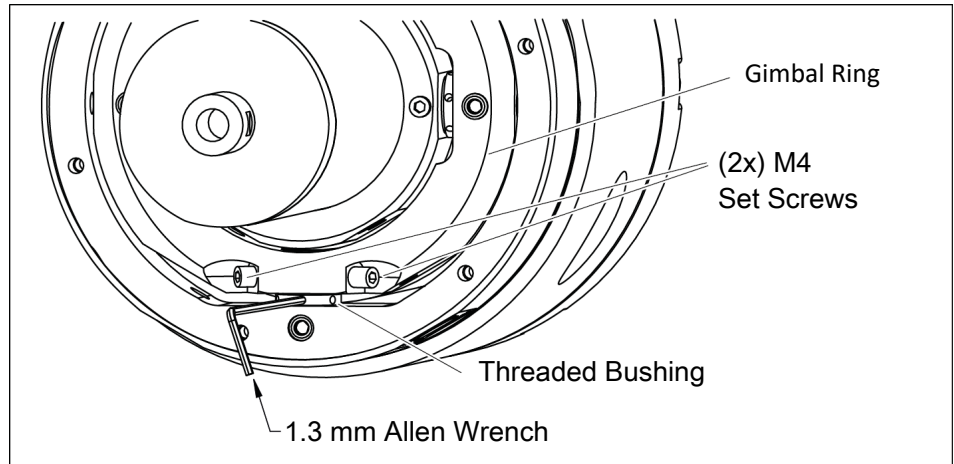

- 13.** Using a 2 mm Allen wrench, loosen the 2 M4 set screws at the bottom of the gimbal ring.
- 14.** Using a 1.3 mm Allen wrench inserted into the side hole of the threaded bushing, turn the bushing in toward the gimbal ring.

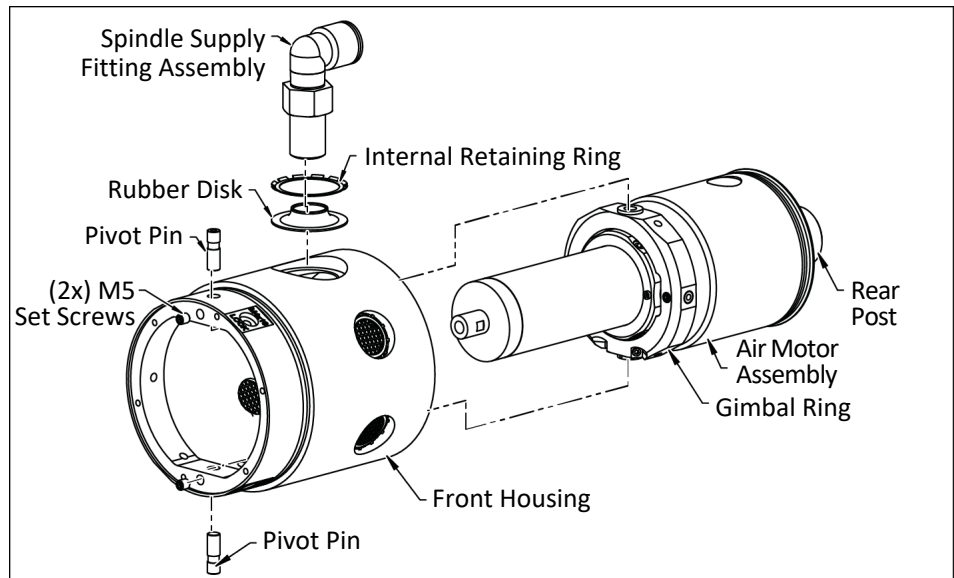

- 15.** Thread M3 fasteners into the pivot pins.
- 16.** At the front of the front housing assembly, loosen the 2 M5 set screws securing the motor pivot pins until they extend out of the front housing about 3 mm.
- 17.** Pull the M3 fasteners screwed into the pivot pins to extract the pins.
- 18.** Withdraw the air motor complete as an assembly by twisting it and pulling it backward out of the main housing.

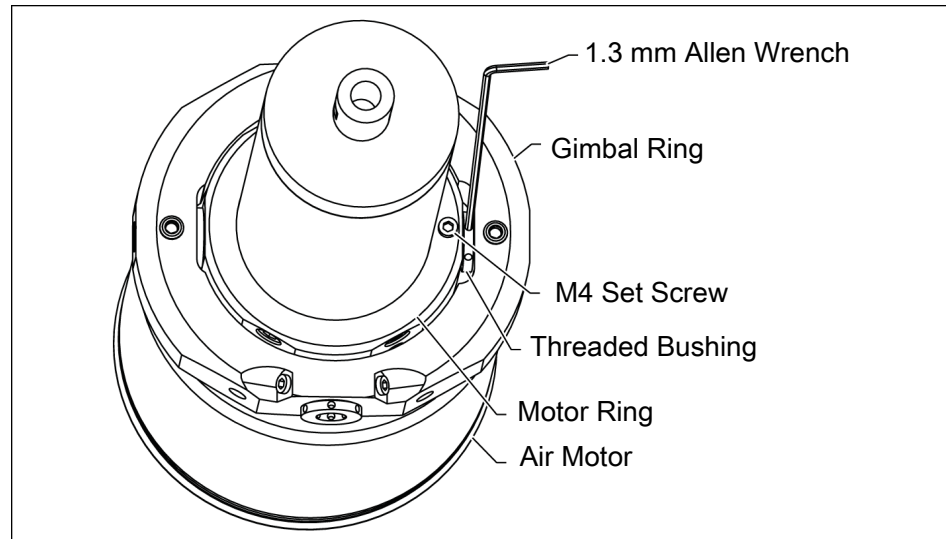

- 19.** Thread M3 fasteners into the pivot pins of the gimbal ring assembly.
- 20.** At the front of the gimbal ring assembly, use a 2.5 mm Allen wrench to loosen the 2 M5 set screws securing the motor pivot pins until they extend out of the front housing about 3 mm.
- 21.** Using a 2 mm Allen wrench, loosen the M4 set screws at the bottom of the motor ring.
- 22.** Using a 1.3 mm Allen wrench inserted into the side hole of the threaded bushing, turn the bushing in toward the motor ring.

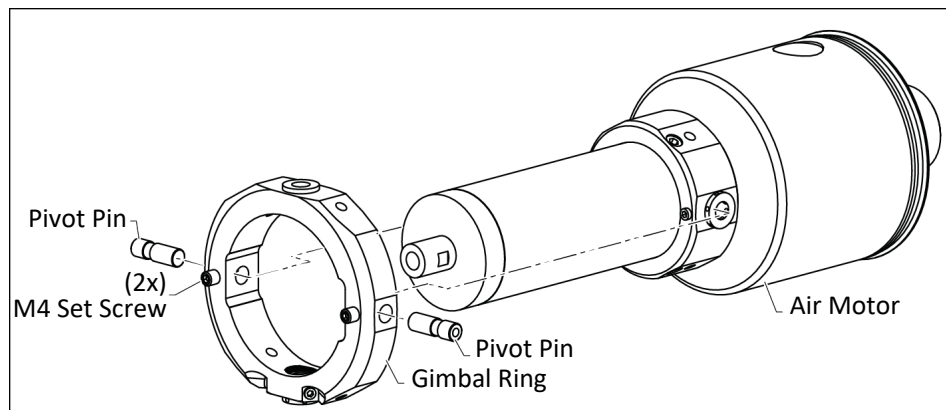

- 23.** Pull the M3 fasteners screwed into the pivot pins to extract the pins.
- 24.** Remove the gimbal ring.

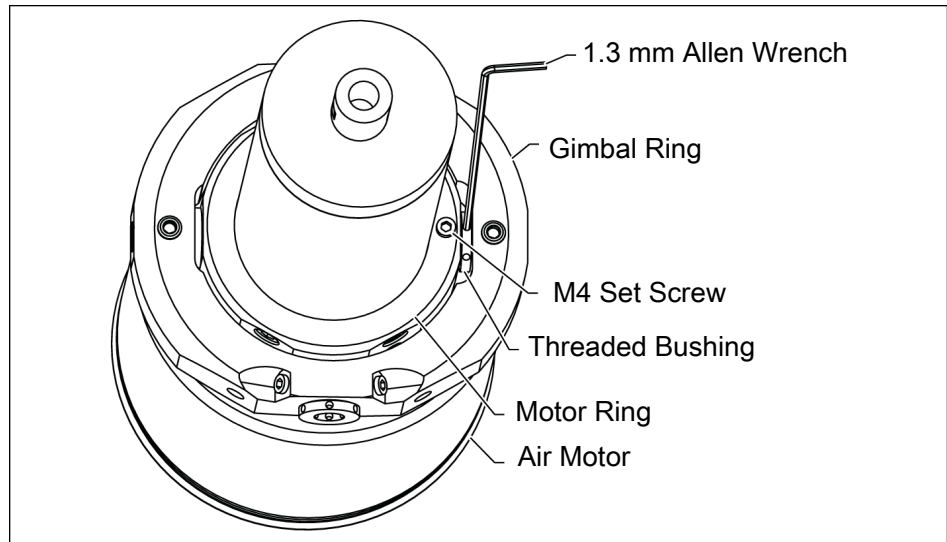

- 25.** Install the gimbal ring on the new air motor assembly make sure the wave spring is held in place on the inside of the gimbal ring by coating it with grease.
- 26.** Insert the pivot pins to secure the gimbal ring in place.
- 27.** Using a 4 mm Allen wrench, install the 2 M5 set screw into the gimbal ring to secure the pivot pins. Tighten to 2.82 Nm.
- 28.** Using a 1.3 mm Allen wrench inserted into the side hole of the threaded bushing, turn the bushing in toward the gimbal ring until contact then back it off 1/6 of a turn (one through hole).
- 29.** Using a 2 mm Allen wrench, tighten the M4 set screw at the bottom of the motor ring to 2.82 Nm.

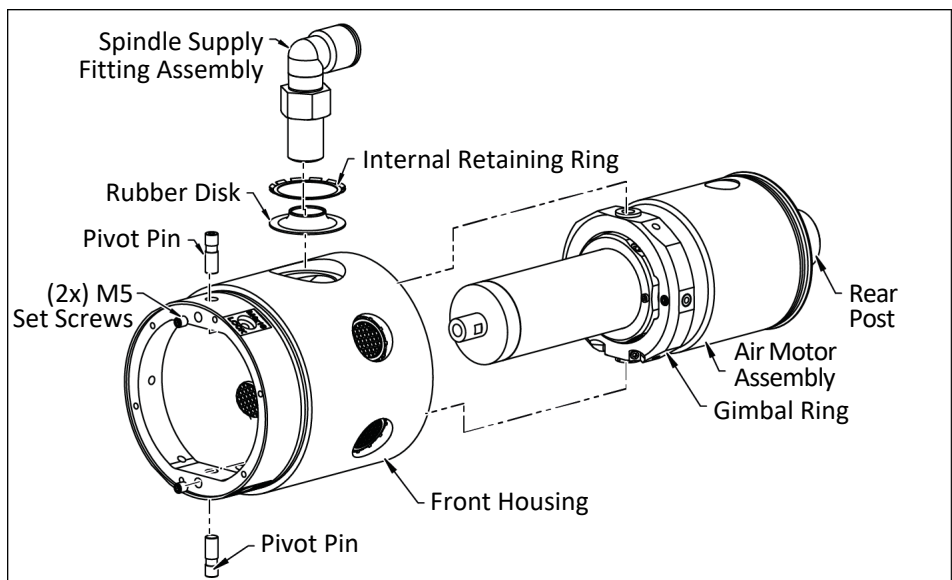

- 30.** Insert the new air motor and gimbal assembly into the front housing assembly.
- 31.** Insert the pivot pins to secure the air motor in place. Make sure the wave spring remains in place.

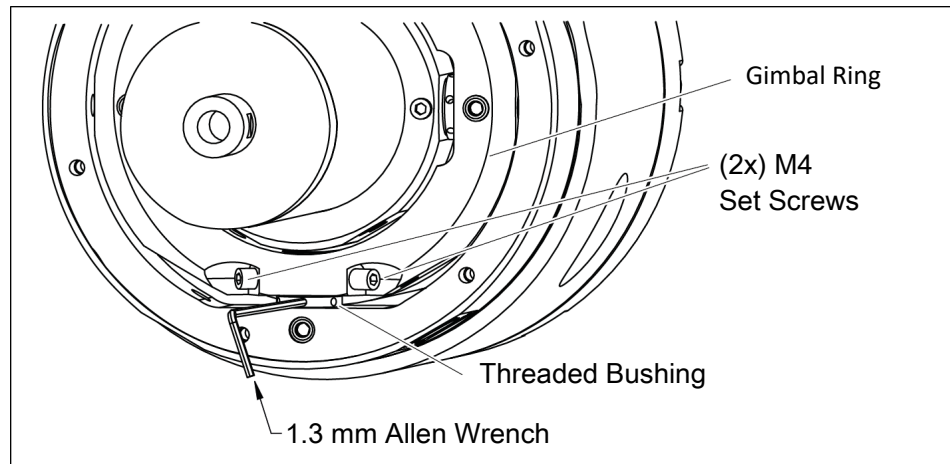

- 32.** Using a 4 mm Allen wrench, install the 2 M5 set screw into the front housing assembly to secure the pivot pins. Tighten to 2.82 Nm.
- 33.** Using a 1.3 mm Allen wrench inserted into the side hole of the threaded bushing, turn the bushing in toward the housing until contact then back it off 1/6 of a turn (one through hole).
- 34.** Using a 2 mm Allen wrench, tighten the 2 M4 set screws at the bottom of the gimbal ring to 2.82 Nm.

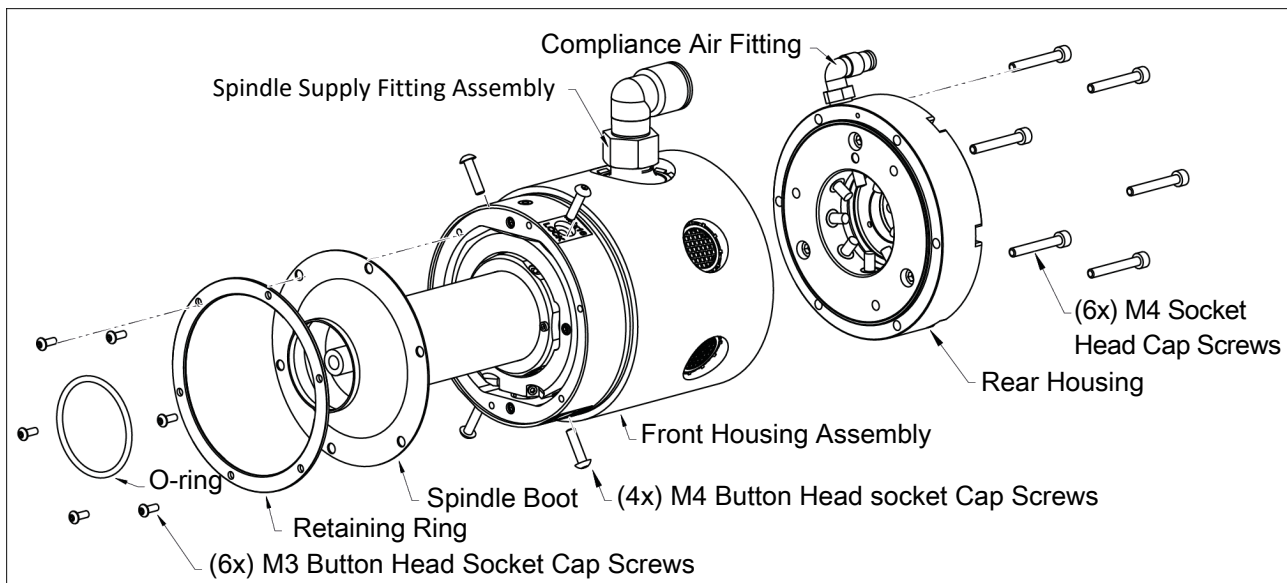

- 35.** Apply a coating of Magnalube on the rear post of the air motor assembly.
- 36.** Apply Loctite 222 to the 6 M4 socket head cap screws.
- 37.** Align the rear housing to the front housing assembly and secure with the 6 M4 socket head cap screws. Tighten to 2.82 Nm.
- 38.** Slide the disk boot over the air motor spindle and align to the front housing assembly.
- 39.** Apply Loctite 222 to the 6 M3 button head socket cap screws

- 40.** Fit the boot retaining ring over disk boot and secure with 6 M3 button head socket cap screws using a 2.5 mm Allen wrench. Tighten to contact and an additional 1/2 turn.

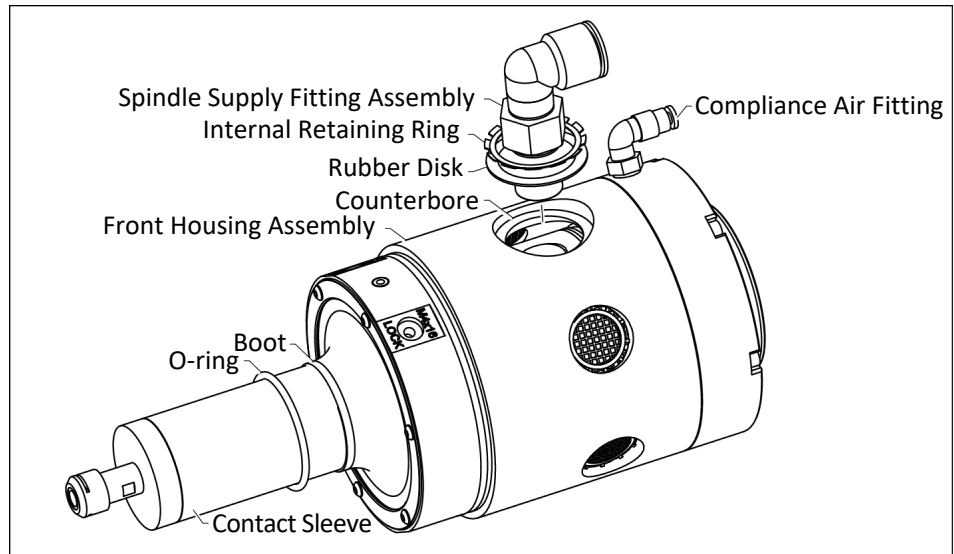

- 41.** Assemble the O-ring over the disk boot, it will seat in the groove in the air motor assembly.
- 42.** Assemble the new internal retaining ring and rubber disk to the spindle supply fitting as shown in the figure.
- 43.** Apply non-hardening thread sealant to the threads of the spindle supply fitting.
- 44.** Thread the spindle supply fitting into the air motor assembly until it is finger tight then tighten an additional 1/2 turn.
- 45.** Slide the rubber disk into the counter bore in the front housing.
- 46.** Push the internal retaining ring into the counter bore to secure the rubber disk.
- 47.** If the tool was locked to single axis compliance before air motor replacement, apply Loctite 7649 and 222 to and install the 4 M4 x 16 mm button head socket cap screws. Tighten to 2.82 Nm.
- 48.** Install the deburring tool to the robot or work location.
- 49.** Connect the air hose to the spindle supply fitting and the compliance air fitting.
- 50.** Apply and/or unlock the spindle motor air supply.

8.3.3 Pivot Bearing Replacement

The pivot bearing allows articulation of the motor assembly. The pivot bearing is subject to wear and should be replaced when excessive spindle motion is observed. Contact between the motor air supply fitting and the main housing indicates pivot bearing

wear which should be corrected. To minimize possible downtime, the pivot bearing should be replaced any time the air motor is replaced.

The pivot bearing may be replaced in one of two ways. For quick repairs with minimal downtime the user is encouraged to replace the entire rear housing assembly. When a spare unit can be placed into service or downtime is not an issue a new pivot bearing can be installed in an existing rear housing.

8.3.3.1 Pivot Bearing Replacement FDB 150

The articulation of the air motor spindle is accomplished using a gimbal suspension. After prolonged heavy use, the bearings in this suspension may require replacement. There are two bearings in the outer gimbal ring and two bearings in the black anodized ring on the motor subassembly. Should the bearings require replacement refer to the steps below:

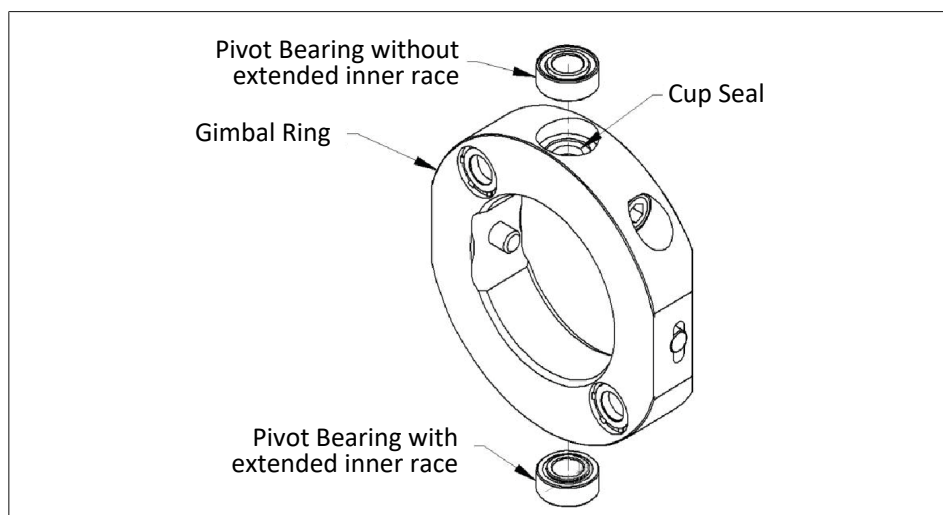

1. Remove the air motor as described in steps 1 through 16 in Section "Air Motor Replacement" ▶ 8.3.2.1 [39].
2. Remove the gimbal ring from the motor assembly as described in Section "Air Motor Replacement" ▶ 8.3.2.1 [39].
3. The bearings of each ring are now accessible. To remove the bearings, use a suitable pair of pliers to grab the outer race and pull the bearing out of the ring. (The bearings are only lightly retained.) Alternatively, a hooked piece of wire can be inserted in the bearing bore to pull the bearings out.
4. Apply a tiny amount of non-hardening gasket sealant (Permatex #2 or equivalent) to the outer race of the new bearings to secure them during the reassembly process. Only the smallest amount is required.

5. Insert the pivot bearing without an extended inner race into the bore with the cup seal in the bottom. Insert the bearing with the extended inner race into the other bore.
6. Reassemble as described in steps 17 through 35 in Section "Air Motor Replacement" ▶ 8.3.2.1 [39].

8.3.3.2 Pivot Bearing Replacement FDB 300 / FDB 340

Early FDB units can be identified by their lack of radial and axial tapped holes for the pivot bearing keying dowel (see Figure). During maintenance of these units the customer should replace the entire rear housing assembly to upgrade the deburring tool. The early style of pivot bearing and rear housing are not currently supported.

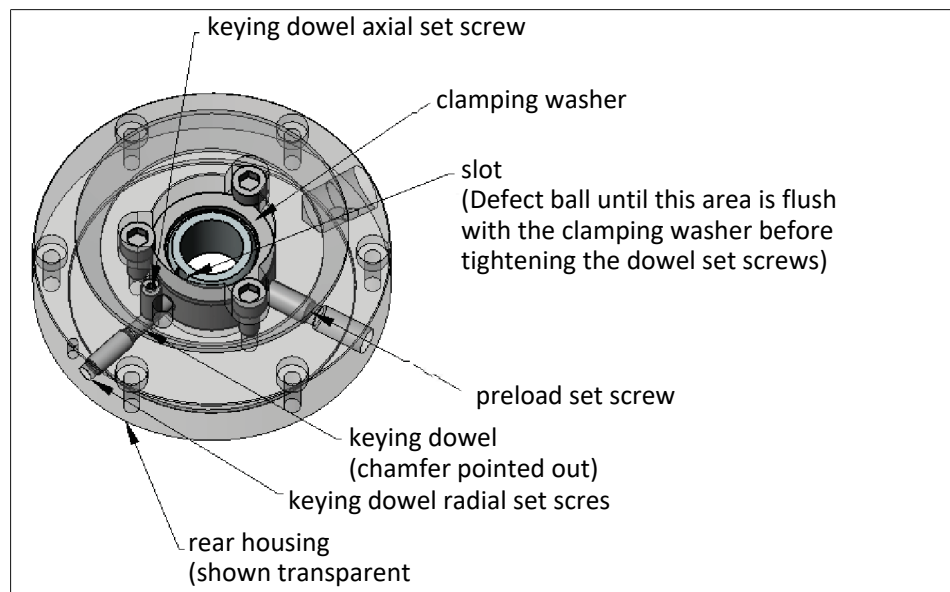

Rear Housing Assembly Replacement

1. Remove the brass plug or hex socket screw from the center of the deburring unit's rear housing.
2. Remove the socket head screws securing the rear housing to the deburring tool's front housing.
3. Remove the rear cover complete with the pivot bearing. Retain the small o-ring and dowel pin between the cover and housing for reuse if desired.
4. The new rear housing assembly will be provided with new fasteners and a new o-ring. Reassembly is the reversal of the previous steps with the following points:
 - ⇒ Insure the dowel pin and small o-ring that go between the housing and the rear cover are in place before refitting the rear cover.
 - ⇒ Use liquid thread locker on all the socket head screws, but NOT on the brass pivot post plug (where applicable).

Pivot Bearing & Keying Dowel Replacement

- ⇒ Insure that the spindle air supply fitting is centered in the housing (side boot) opening prior to tightening the fastener in the pivot bearing post.

NOTE

Always replace the pivot bearing keying dowel when the bearing is replaced

1. Remove the rear housing assembly as described above.
2. Remove the three socket head screws securing the pivot bearing in the center of the rear housing.
3. Remove the large clamping washer which rests on top of the pivot bearing.
4. Locate and loosen the radially tapped bearing preload set screw in the rear housing.
5. Locate the two set screws securing the pivot bearing keying dowel in the rear housing. One will be radially tapped in the rear housing and the second will be axially tapped on the rear mounting surface. Remove both screws.
6. Use a small diameter magnet or a powerful magnet attached to the side of a hex key to reach inside the keying dowel pin hole and remove the keying dowel pin from the rear housing.
7. With the dowel pin removed the old pivot bearing can be pressed from the rear housing.
8. Reassembly is the reversal of the previous steps with the following points:
 - ⇒ Insure that the hole in the outer race of the new pivot bearing lines up with the radial dowel pin hole in the rear housing and insert the pivot bearing in the rear housing bore.
 - ⇒ Always use a new keying dowel pin. Insert the keying dowel pin with its crowned (radiused) end first so it rests in the slot machined in the pivot bearing's ball.
 - ⇒ Apply low strength thread locker such as Loctite-222 to the socket head screws used to secure the clamping washer and refit both the washer and screws to the rear housing. Leave the fasteners finger-tight at this time.
 - ⇒ Sparingly apply a low strength thread locker to the keying dowel pin set screws and insert both set screws in the rear housing.

- ⇒ Adjacent to the keying dowel pin, pivot the bearing's ball by several degrees until the ball's top surface is flush with the clamping washer. Tighten the keying dowel's radial set screw until it just contacts the end of the dowel.
- ⇒ While holding the pivot bearing ball in the deflected position tighten the keying dowel's axial set screw securely to lock the dowel pin in place
- ⇒ Apply two or three drops of light machine oil (or 30 weight engine oil) to the ball of the pivot bearing and its keying slot.
- ⇒ Refit the rear housing assembly as described in the previous section.

Once installed on the deburring tool, tighten the bearing preload set screw until slight resistance to motion can be felt when the spindle is articulated like a joystick. Tighten all socket head cap screws securely. Do not tighten the set screws further.

8.3.4 Ring Cylinder Assembly Replacement

The compliance and articulation of the air motor spindle is accomplished using a circular array of pistons (ring cylinder) at the rear of the FDB housing. After extended operation, this component may need replacing to insure free motion of the pistons. The unit may be replaced as an assembly, but its subcomponents are not user-serviceable. To replace the ring cylinder assembly, perform the steps in the following chapters.

8.3.4.1 Ring Cylinder Assembly FDB 150

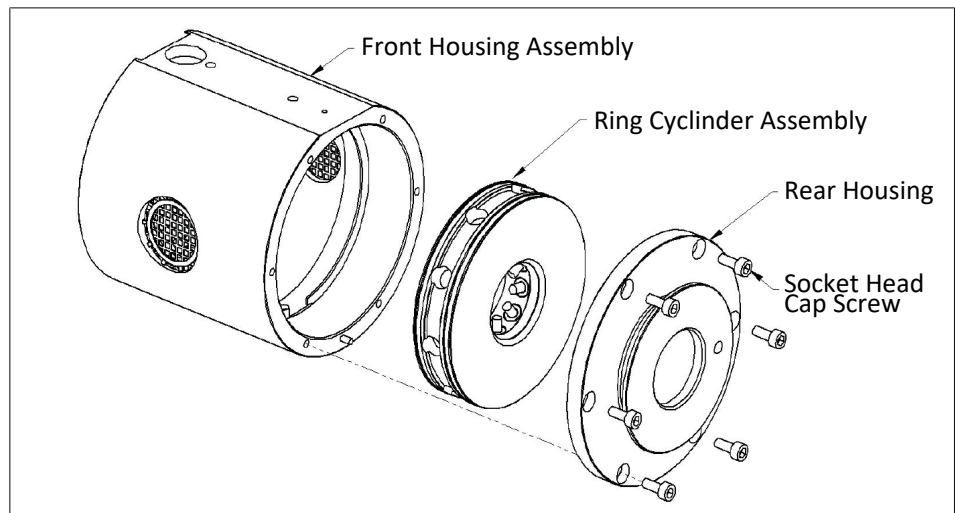

1. Remove the air motor as described in steps 1 through 14 in ► 8.3.2.1 [39].
2. Remove the six socket head cap securing the rear housing to the front housing assembly.
3. Remove the rear housing.

4. Invert the unit and press the ring cylinder assembly outwards to the rear. Use a non-metallic drift to prevent damage. (It may be necessary to use a small arbor press and support plate to remove the ring cylinder if the unit has been in service for a prolonged time).
5. To reassembly, apply a thin film of grease or oil to the bore in the front housing assembly where the ring cylinder seats prior to installation.
6. Use hand pressure and a flat plate to press the ring cylinder into the rear bore of the front housing assembly until it reaches the retaining ring.
7. Apply Loctite 7649 Primer® and Loctite 222® to the threads of the six socket head cap screws that secure the rear housing to the front housing assembly.
8. Install the rear housing to the front housing assembly and secure with six socket head cap screws and torque to 1.35 Nm.
9. Reassemble as described in steps 22 through 39 in ► 8.3.2.1 [📄 39].

8.3.4.2 Ring Cylinder Assembly FDB 300 / FDB 340

1. Remove the air motor as described previously.
2. Remove the front spindle boot and its retaining ring by extracting the socket head screws at the front of the housing.
3. Use a small flat blade screwdriver to pry the ring cylinder retaining ring free and remove it from the front of the housing.
4. From inside the housing, use a non-metallic drift to press the ring cylinder out of the housing. (After prolonged periods of use the o-ring seals may make removal of the compliance unit difficult. If this occurs, support the front of the housing on a suitable plate with a clearance hole for the ring cylinder and use an arbor press for extraction.) Retain the small o-ring and dowel pin for reuse. Always replace the large o-rings on the outside of the ring cylinder assembly when it is reinstalled.
5. Replacing the ring cylinder assembly is the reversal of these steps with the following points.
 - ⇒ Apply a thin film of grease or oil to the housing bore where the ring cylinder seats prior to installation.
 - ⇒ Fit new o-rings to the outside of the ring cylinder assembly if the old unit is being reinstalled. (Do not reuse the old o-rings.)

- ⇒ Insure that the small o-ring and dowel pin are in place inside the housing before sliding the ring cylinder assembly into place.
- ⇒ Align the assembly marks on the housing entrance and the flat surface of the ring cylinder assembly prior to pressing the ring cylinder in the bore.
- ⇒ Use hand pressure and a flat plate to press the ring cylinder into the housing and past the retaining ring groove.

8.3.4.3 Ring Cylinder Assembly FDB 990 / FDB 1040

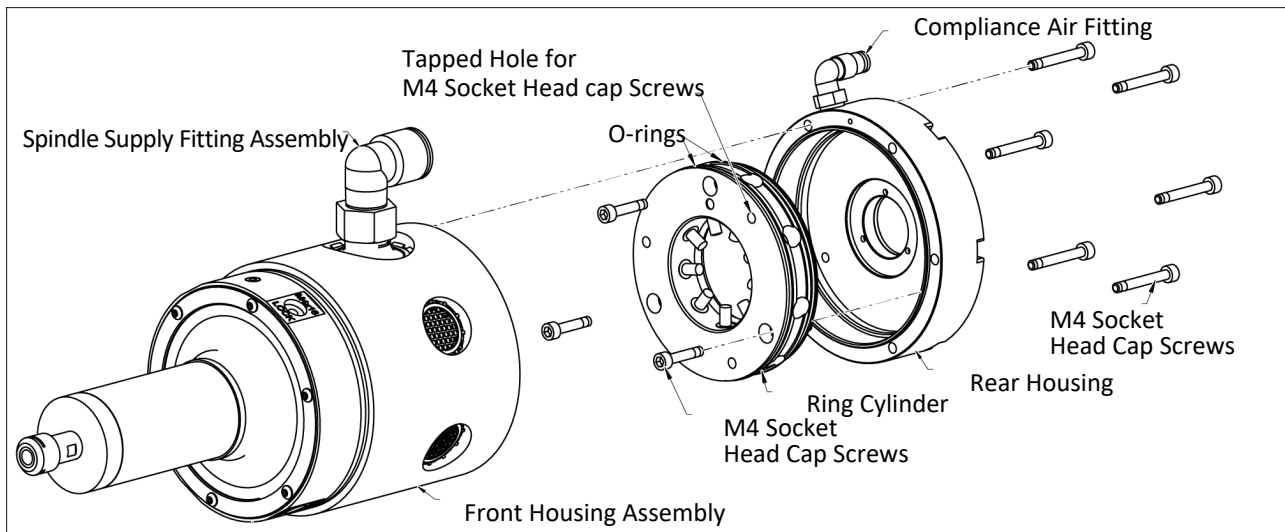

1. Remove and/or lock-out the spindle motor air supply for safety.
2. Disconnect the air hose from the spindle supply fitting and the compliance air fitting.
3. Remove the deburring tool from the robot or work location.
4. Clean the debris from the deburring tool using compressed air and a clean rag to wipe any grease from the outer surfaces.
5. Using a 2 mm Allen wrench, remove the M4 socket head cap screws (6x) securing the rear housing to the front housing.
6. Remove the rear housing.
7. Using a 2 mm Allen wrench, remove the M4 socket head cap screws (3x) securing the ring cylinder assembly to the rear housing.
8. Place the removed M4 screws in the tapped holes in the ring cylinder body and tighten them slowly and equally, so they push the ring cylinder assembly out of the rear housing.
9. Apply a thin film of grease or oil to the housing bore where the ring cylinder seats prior to installation.

10. Insert the new ring cylinder assembly into the rear housing. Align the ring cylinder assembly using the mounting screws prior to pressing the ring cylinder in the bore.
11. Apply Loctite 222 to the M4 socket head cap screws (3x).
12. Place the M4 screws in the through holes in the ring cylinder body and tighten them slowly and equally using a 2 mm Allen wrench, so they pull the ring cylinder assembly into of the rear housing. **NOTICE! Be sure O-ring stay properly seated into grooves. Tighten to 2.82 Nm.**
13. Assemble the rear housing to the front housing.
14. Apply Loctite 222 to the M4 socket head cap screws (6x). Secure the rear housing using the 6 M4 socket head cap screws using a 2 mm Allen wrench. Tighten to 2.82 Nm.
15. Install the FDB to the robot or work location.
16. Connect the air hose to the spindle supply fitting and the compliance air fitting.
17. Apply and/or unlock the spindle motor air supply.

8.3.5 Spindle Boot Replacement FDB 660

The spindle boot prevent debris from entering the housing and protects internal components.

Replace the spindle boot if damaged.

8.3.5.1 Spindle Boot Replacement FDB 900 / 1040

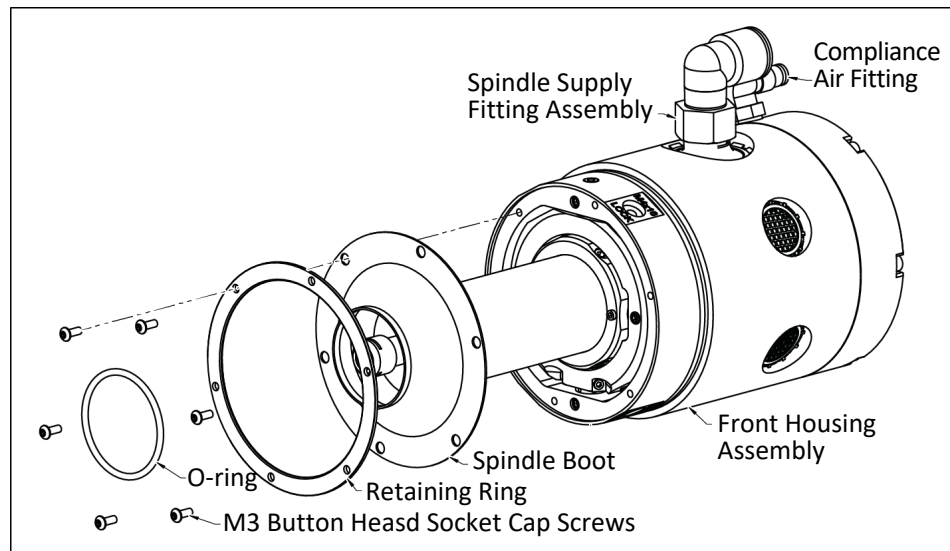

1. Remove and/or lock-out the spindle motor air supply for safety.
2. Disconnect the air hose from the spindle supply fitting and the compliance air fitting.
3. Remove the deburring tool from the robot or work location.

- 4.** Clean the debris from the deburring tool using compressed air and a clean rag to wipe any grease from the outer surfaces.
- 5.** Ease the O-ring off the front spindle boot.
- 6.** Using a 2.5 mm Allen wrench, remove the (6) M3 button head socket cap screws securing the retaining ring to the front housing assembly.
- 7.** Remove the retaining ring and spindle boot.
- 8.** Align the spindle boot and the retaining ring with the holes in the ring cylinder and slide the boot onto the air motor and align the edge of the boot to the edge of the contact sleeve
- 9.** Apply Loctite 222 to the threads of the M3 socket button head cap screws.
- 10.** Secure the spindle boot and retaining ring to the front housing using the (6) M3 button head socket cap screws using a 2.5 mm Allen wrench. Tighten to contact plus one additional flat.
- 11.** Stretch the O-ring over the boot, it will seat in the groove on the contact sleeve.
- 12.** Install the deburring tool to the robot or work location.
- 13.** Connect the air hose to the spindle supply fitting and the compliance air fitting.
- 14.** Apply and/or unlock the spindle motor air supply.

9 Transport and storage

9.1 Transportation and Protection during Transportation

The FDB is packaged in a crate designed to secure and protect it during transportation. Always use the crate when transporting the deburring tool in order to minimize the risk of damage.

9.2 Storage and Preventive Maintenance during Storage

The FDB should be stored in its crate when it is not in use. The FDB should also be stored in a dry place.

For long-term storage, the FDB should be thoroughly cleaned of any burrs or debris. It should not be disassembled. Place the FDB inside a sealed plastic bag and place the FDB inside the crate.

10 Translation of the original declaration of incorporation

in terms of the Directive 2006/42/EG, Annex II, Part 1 Section B.

Manufacturer/
Distributor SCHUNK SE & Co. KG
Spanntechnik | Greiftechnik | Automatisierungstechnik
Bahnhofstr. 106 – 134
D-74348 Lauffen/Neckar

We hereby declare that the partly completed machine described below

Product designation: Radially flexible pneumatic deburring tool / FDB /pneumatic
ID number 0322200, 0322201, 0322202, 0322203, 0322205, 0322208, 0322240,
0322245

meets the following basic occupational health and safety of the Machinery Directive 2006/42/EC:

No. 1.1.1, No. 1.1.2, No. 1.1.3, No. 1.1.5, No. 1.3.2, No. 1.5.3, No. 1.5.4, No. 1.5.6, No. 1.5.8, No. 1.5.10, No. 1.5.11, No. 1.5.13

The partly completed machinery may not be put into operation until it has been confirmed that the machine into which the partly completed machinery is to be installed complies with the provisions of the Machinery Directive (2006/42/EC). The declaration shall be rendered invalid if modifications are made to the product.

The special technical documentation according to Annex VII, Part B, belonging to the partly completed machine, has been created.

Person authorized to compile the technical documentation:
Stefanie Walter, Address: see manufacturer's address

Signature: see original declaration

Lauffen/Neckar, February 2025

Dr.-Ing. Manuel Baumeister,
Head of Systems Engineering,
Technology & Innovation

11 UKCA declaration of incorporation

in accordance with the Supply of Machinery (Safety) Regulations 2008.

Manufacturer/ Distributor	SCHUNK Intec Limited Clamping and gripping technology 3 Drakes Mews, Crownhill MK8 0ER Milton Keynes
------------------------------	---

We hereby declare that on the date of the declaration the following partly completed machine complied with all basic safety and health regulations found in the "Supply of Machinery (Safety) Regulations 2008".

The declaration shall be rendered invalid if modifications are made to the product.

Product designation:	Radially flexible pneumatic deburring tool / FDB / pneumatic
ID number	0322200, 0322201, 0322202, 0322203, 0322205, 0322208, 0322240, 0322245

The partly completed machine may not be put into operation until it has been confirmed that the machine into which the partly completed machine is to be installed complies with the provisions of the "Supply of Machinery (Safety) Regulations 2008".

The special technical documentation according to Annex VII, Part B, belonging to the partly completed machine, has been created.

Person authorized to compile the technical documentation:
Marcel Machado, address: refer to manufacturer's address



Lauffen/Neckar, February 2025

Dr.-Ing. Manuel Baumeister,
Head of Systems Engineering,
Technology & Innovation

12 Information on the RoHS Directive, REACH Regulation and Substances of Very High Concern (SVHC)

RoHS Directive

SCHUNK products are classified as "large-scale stationary installations" or as "large-scale stationary industrial tools" within the meaning of Directive 2011/65/EU and its extension 2015/863/EU "on the restriction of the use of certain hazardous substances in electrical and electronic equipment (RoHS)", or fulfill their intended function only as part of one. Therefore products from SCHUNK do not fall within the scope of the directive at this time.

REACH Regulation

Products from SCHUNK fully comply with the regulations of Regulation (EC) No. 1907/2006 "concerning the Registration, Evaluation, Authorization and Restriction of Chemicals (REACH)" and its amendment 2022/477. SCHUNK attaches great importance to completely avoiding chemicals of concern to humans and the environment wherever possible.

Only in rare exceptional cases do SCHUNK products contain SVHC substances on the candidate list with a mass content above 0.1%. In accordance with Article. 33 (1) of Regulation (EC) No. 1907/2006, SCHUNK complies with its duty to "communicate information on substances in articles" and lists the components concerned and the substances used in an overview that can be viewed at [schunk.com/SVHC](https://www.schunk.com/SVHC).

Signature: see original declaration

Lauffen/Neckar, February 2025

Dr.-Ing. Manuel Baumeister,
Head of Systems Engineering,
Technology & Innovation

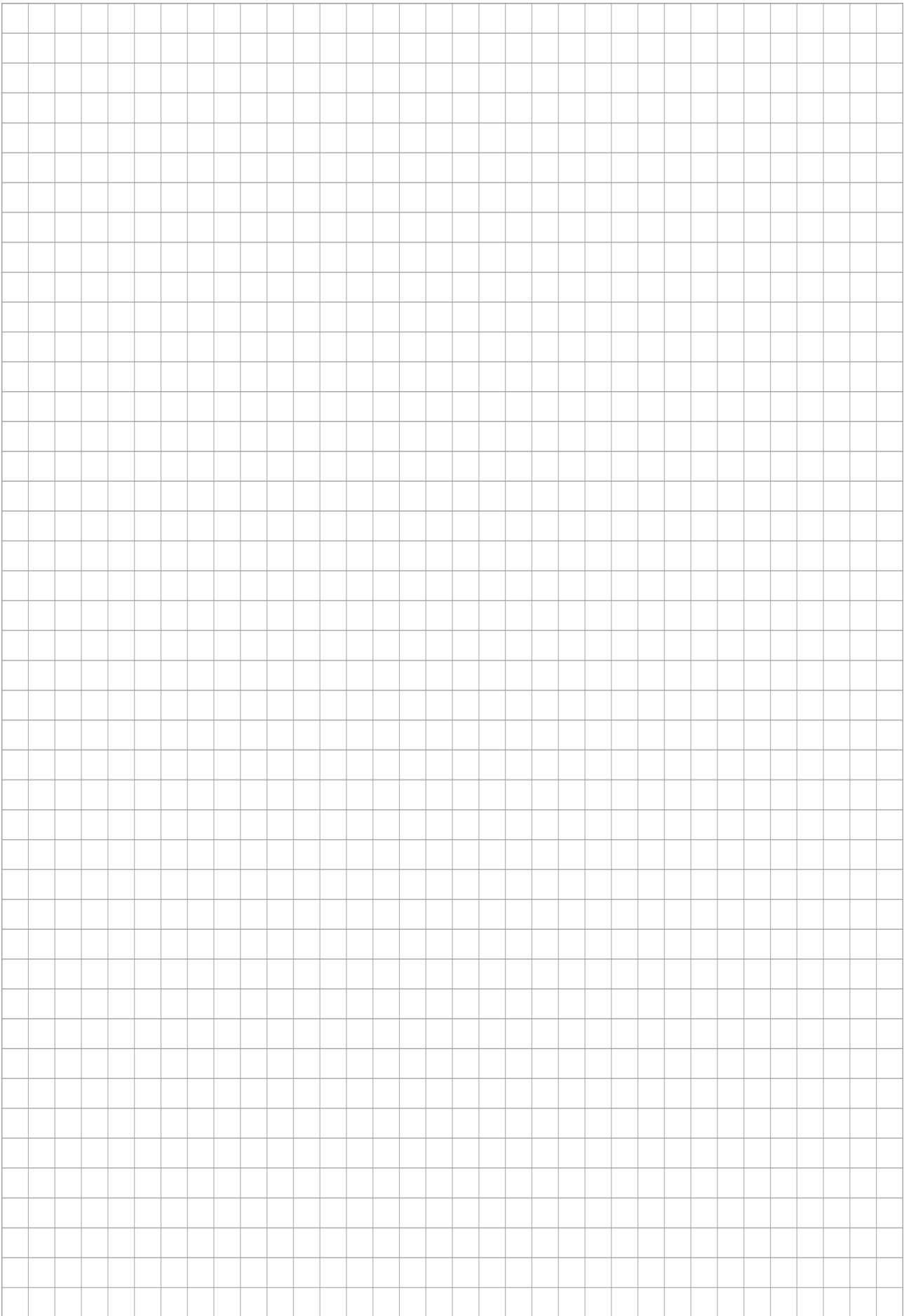

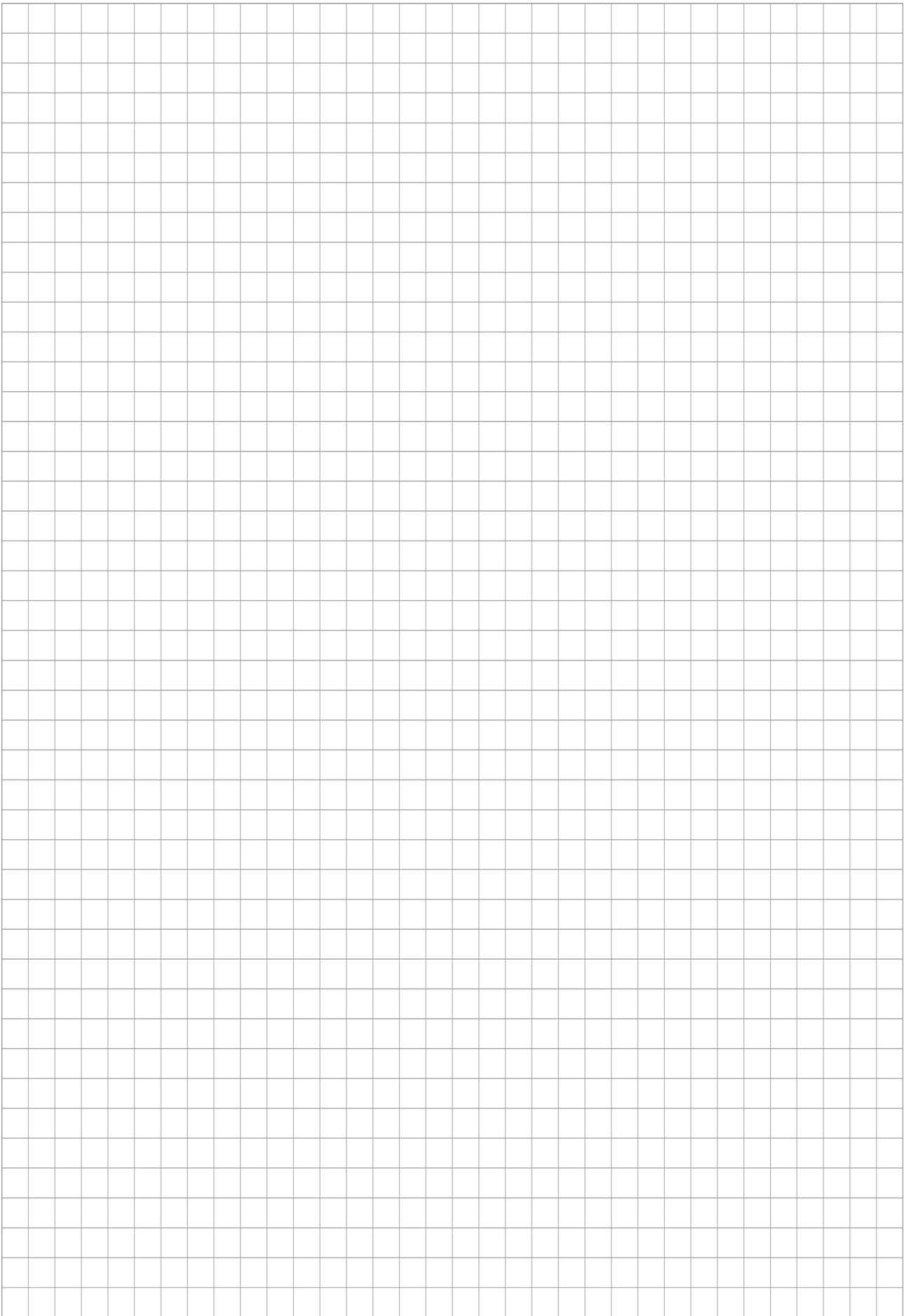

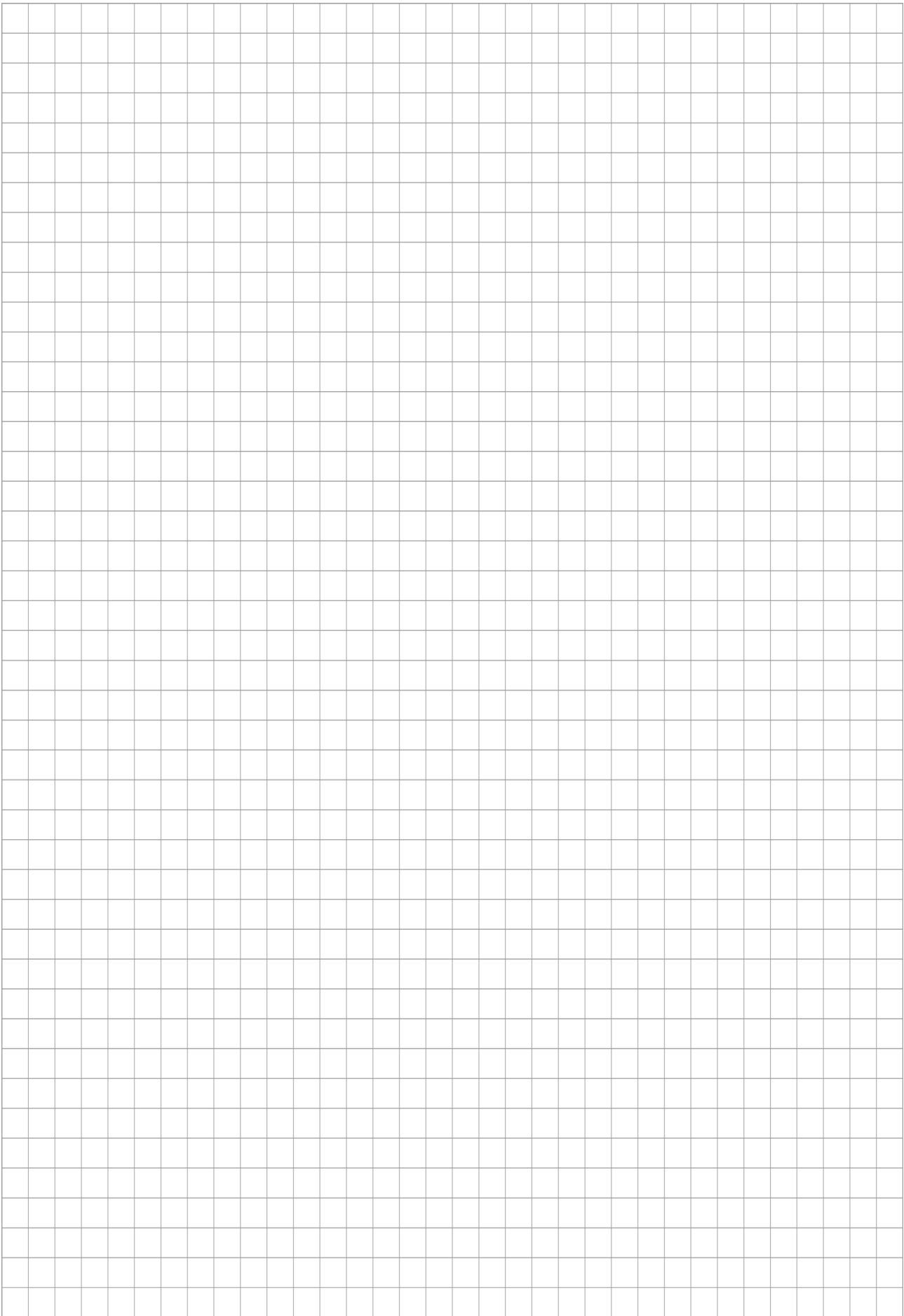



SCHUNK SE & Co. KG
Spanntechnik | Greiftechnik | Automatisierungstechnik

Bahnhofstr. 106 - 134
D-74348 Lauffen/Neckar
Tel. +49-7133-103-0
info@de.schunk.com
schunk.com

Folgen Sie uns | *Follow us*



Wir drucken nachhaltig | *We print sustainable*