

Servo-electric rotary pan-tilt actuator

Type PW 70-90

Assembly and operating manual



Imprint:

Copyright:

This manual remains the copyrighted property of SCHUNK GmbH & Co. KG. It is solely supplied to our customers and operators of our products and forms part of the unit. This documentation may not be duplicated or made accessible to third parties, in particular competitive companies, without our prior permission.

Technical changes:

We reserve the right to make alterations for the purpose of technical improvement.

Document number: 0389353

Edition: 02.01-A / 14.08.2012 / en

© SCHUNK GmbH & Co. KG, Lauffen/Neckar

All rights reserved

Dear Customer,

Congratulations on choosing a SCHUNK product. By choosing SCHUNK, you have opted for the highest precision, top quality and best service.

You are going to increase the process reliability of your production and achieve best machining results – to the customer's complete satisfaction.

SCHUNK products are inspiring.

Our detailed assembly and operation manual will support you.

Do you have further questions? You may contact us at any time – even after purchase. You can reach us directly at the mentioned addresses in the last chapter of these instructions.

Kindest Regards,

Your SCHUNK GmbH & Co. KG
Precision Workholding Systems
Bahnhofstr. 106 – 134
D-74348 Lauffen/Neckar

Tel. +49-7133-103-2503
Fax +49-7133-103-2189
automation@de.schunk.com
www.schunk.com



Table of contents

1	About this manual.....	5
1.1	Purpose/validity	5
1.2	Target groups.....	5
1.3	Applicable documents	5
1.4	Symbols in this manual	6
1.5	Terms used in this manual	6
2	Basic safety notes	7
2.1	Intended use	7
2.2	Environmental and operating conditions	7
2.3	Controlled production	7
2.3.1	Condition of the inputs/ outputs (I/O)	8
2.3.2	Protective equipment.....	8
2.3.3	Constructional changes, attachments or modifications.....	8
2.3.4	Special standards	8
2.4	Personnel qualification	9
2.5	Safety-conscious working.....	9
2.6	Notes on particular risks.....	10
3	Warranty	11
4	Scope of delivery	11
5	Accessories.....	12
5.1	Connecting elements	12
6	Technical Data	13
6.1	Basic data	13
6.2	Factory settings / DEFAULT Value	14
6.3	Power supply requirements.....	14
7	Description of the module.....	15
7.1	Structure.....	15
7.2	Functional principle	16
7.3	Connection cap board	17
8	Assembly and commissioning	18
8.1	Mechanical Connection.....	18

8.2	Example of mounting	19
8.3	Electrical connection	19
8.3.1	EMV-fitting.....	20
8.3.2	RS232 interface.....	23
8.3.3	CAN interface	25
8.3.4	Interface PROFIBUS DP	28
8.3.5	DEFAULT and BOOT function.....	30
8.4	System integration	32
8.4.1	System structure.....	32
8.4.2	SCHUNK Motion protocol.....	32
8.4.3	Most important commands	33
9	Troubleshooting.....	38
9.1	Module does not move	38
9.2	The module is sluggish or jerky	38
9.3	The module's motor is not turning	38
9.4	Module stops abruptly	38
10	Maintenance and care	39
10.1	Maintenance intervals	39
10.2	Dismantling the module.....	39
11	EC declaration of incorporation	40

1 About this manual

1.1 Purpose/validity

This manual is part of the module and describes the safe and proper use during all phases of operation.

This manual is valid only for the module specified on the front page.

1.2 Target groups

Target group	Task
Manufacturer, operator	<ul style="list-style-type: none"> ➔ Keep this manual available for the personnel at all times. ➔ Require personnel to read and observe this manual and the applicable documents, especially the safety notes and warnings.
Skilled personnel, fitter	<ul style="list-style-type: none"> ➔ Read, observe and follow this manual and the applicable documents, especially the safety notes and warnings.

Table 1

1.3 Applicable documents

You can find the following documents on our homepage:

Document	Purpose
Catalog	Technical data or application parameters of the module and information on accessories. The last version is always valid.
Software manual (MotionControl.pdf)	More detailed information about the parameters and special features of the individual bus systems.
General terms of business	Including notes on the warranty.

Table 2

1.4 Symbols in this manual

To give you quick access to information, the following symbols will be used in this guide:





Symbol	Designation
 DANGER	Dangers for persons. Nonobservance causes death or serious injuries.
 WARNING	Dangers for persons. Nonobservance can cause death or serious injuries.
 NOTICE	Information on avoiding material damage, for explanation or to optimize the work processes.
✓	Prerequisite for a handling instruction.
➔	Handling instruction, also measures in a warning or note.
1. 2. 3. ...	Step-by-step handling instruction. ➔ Observe the order.
	Component/spare part represented in a graphic.
	Part/detail shown in a graphic which is part of a spare part or which must be provided by the customer.
(10), (/10/)	Reference in the text or in a handling instruction to a part that is represented in a graphic.
Master M ⇔ Slave S	Parameter will be transferred from Master M to Slave S

Table 3

1.5 Terms used in this manual

Term	Meaning
Cycle	A cycle includes the following movement: ➔ One rotating motion (1x to specified position and 1x back to initial position)

Table 4

2 Basic safety notes

2.1 Intended use

This module has been designed for pivoting and turning workpieces or other objects.

The module is intended for installation in a machine. The requirements of the applicable guidelines must be observed and complied with.

The module may be used only in the context of its defined application parameters.

Any other use or use exceeding that specified is an infringement of use for intended purpose. The manufacturer bears no liability for damage resulting from such use.

2.2 Environmental and operating conditions

- ➔ The module may be used only in the context of its defined application parameters (see chapter 6, page 13 and catalog).
- ➔ Make sure that the environment is clean and the ambient temperature corresponds to the specifications per the catalog. Maintenance intervals. (see chapter 10.1, page 39)
- ➔ Make sure that the environment is free from splash water and vapors as well as from abrasion or processing dust. Excepted are modules that are designed specially for contaminated environments.

2.3 Controlled production

The module represents the state of the art and the recognized safety rules at the time of delivery. However, it can present risks if, for example:

- The module is not used in accordance with its intended purpose.
- The module is not installed or maintained properly.

- The EC Machinery Directive, the VDE directives, the safety and accident-prevention regulations valid at the usage site, or the safety and installation notes are not observed.

2.3.1 Condition of the inputs/ outputs (I/O)

During the run-up of the module not defined I/O conditions may occur.

➔ Do not allow a direct connection with actuators.

2.3.2 Protective equipment

➔ Provide protective equipment per EC Machinery Directive.

2.3.3 Constructional changes, attachments or modifications

Additional drill holes, threads, or attachments that are not offered as accessories by SCHUNK may be attached only with permission of SCHUNK.

2.3.4 Special standards

The following harmonized standards were adhered to:

- Industrial scientific and medical (ISM) radio-frequency equipment - Electromagnetic disturbance characteristics - Limits and methods of measurement (IEC/CISPR 11:2003 + A1:2004, modified + A2:2006); German version EN 55011:2007 + A2:2007 class A (this is equivalent to EN 61000-6-4:2004)
- Electromagnetic compatibility (EMC) - Part 6-2: Generic standards - Immunity for industrial environments (IEC 61000-6-2:2005); German version EN 61000-6-2:2005

2.4 Personnel qualification

The assembly, initial commissioning, maintenance, and repair of the module may be performed only by trained specialist personnel.

The assembly, initial commissioning, maintenance, and repair of the module may be performed only by trained specialist personnel.

Every person called upon by the operator to work on the module must have read and understood the complete Assembly and Operating Manual, especially chapter 2 "Basic safety notes". This applies particularly to occasional personnel such as maintenance personnel.

2.5 Safety-conscious working

- ➔ Avoid any manner of working that may interfere with the function and operational safety of the module.
- ➔ Observe the safety and accident-prevention regulations valid at the usage site.

2.6 Notes on particular risks

Risk of injury from objects falling and being ejected!

- ➔ Provide protective equipment to prevent objects from falling or being ejected, such as processed workpieces, tools, chips, fragments, rejects.

Risk of injury when the machine/system moves unexpectedly!

- ➔ Do not move parts by hand when the energy supply is connected.
- ➔ Do not reach into the open mechanism or the movement area of the module.
- ➔ Remove the energy supplies before installation, modification, maintenance, or adjustment work.
- ➔ Perform maintenance, modifications, and additions outside the danger zone.
- ➔ For all work, secure the module against accidental operation.

3 Warranty

The warranty is valid for 24 months from the delivery date to the production facility under the following conditions:

- Observation of the maintenance intervals (see chapter 10.1, page 39)
- Observation of the ambient conditions and operating conditions (see chapter 2.2, page 7)

Parts touching the workpiece are not part of the warranty. Also observe our general terms of business.

4 Scope of delivery

The scope of delivery includes:

- Servo-electric rotary pan-tilt actuator Type PW in the version ordered
- USB to RS232 converter inclusive driver CD
- DVD

Content of DVD:

- MCDemo (configuration and commissioning tool)
- Operating manual in PDF format
- MotionControl software manual in PDF format

Note

The module is delivered without connection cap ASK. It can be ordered separately as accessory.

Connection cap ASK is necessary for operation.

The following accessories are available for the module:

- Connecting elements (PAM)
- Hybrid cable
- Connection cables

➔ Order accessories separately.

➔ For additional accessories, see catalog.

Notes

Older versions require the PowerConfig tool from the DVD for flashing. If older versions are to be used, contact your SCHUNK representative.

5 Accessories**5.1 Connecting elements**

➔ See catalog for exact type designations of compatible connecting elements.

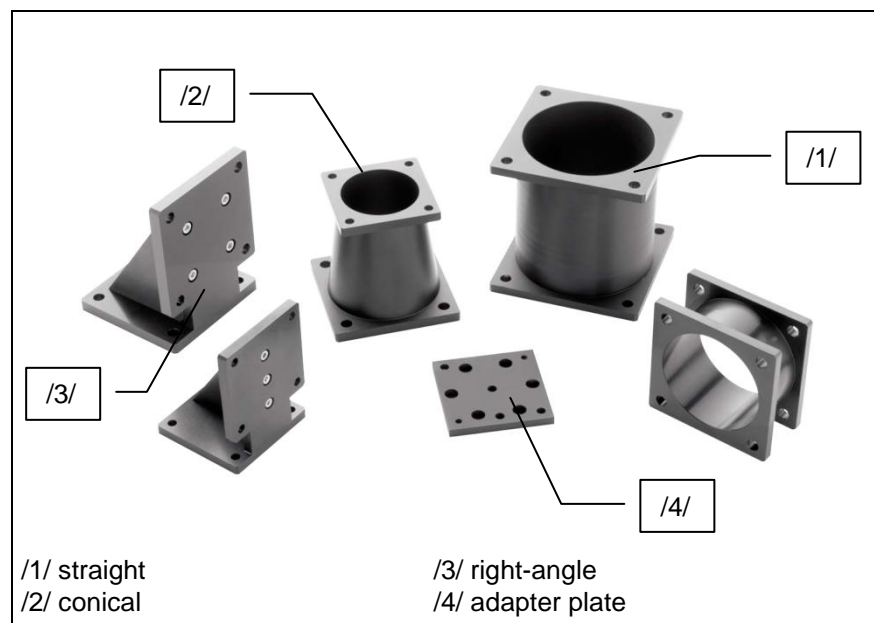

Figure 1

6 Technical Data

6.1 Basic data

Further technical data can be found in our catalog. The most recent version applies.

		Size	70	90
Mechanical operating data		Mass [kg]	1,8	3,4
		Noise emission [dB(A)]	≤ 70	≤ 70
		IP rating (when using DMI-connection cap)	54	54
		Ambient temperature [°C]		
Axis 1	Min.		+5	+5
	Max.		+55	+55
Axis 1		Rated torque [Nm]	12,0	23,0
		Peak torque [Nm]	24,0	46,0
		Angle of rotation [°]	±120	±120
		Max. acceleration [°/s ²]	960	600
		Max. angular velocity [°/s]	240	150
Axis 2		Rated torque [Nm]	2,0	12,0
		Peak torque [Nm]	4,0	24,0
		Angle of rotation [°]	>360	>360
		Max. acceleration [°/s ²]	1440	960
		Max. angular velocity [°/s]	360	240
Electrical operating data		Rated voltage [V DC]	24	24
		Rated current [A]	4	4
		Max. current [A]	8	8
Electronic control unit	Interface			
	RS232	X	X	X
	CAN	X	X	X
	PROFIBUS, DP	X	X	X
	Power supply [V DC]		24	24
	Rated current [A]		0,5	0,5
	Sensor system		Encoder	Encoder

Table 5

6.2 Factory settings / DEFAULT Value

Reference	Axis 1	Axis 2
Interface	RS232	RS232
Data rate	9600	9600
Module address	13	14

Table 6

6.3 Power supply requirements

Designation	Value
Output power supply (motor)	24 V DC
Power supply for logic	24 V DC +10% / -4%; Residual ripple < 150mVSS; Switching peak < 240mVSS
Connection value	Number of modules x Rated module current x 1,2

Table 7

7 Description of the module

7.1 Structure

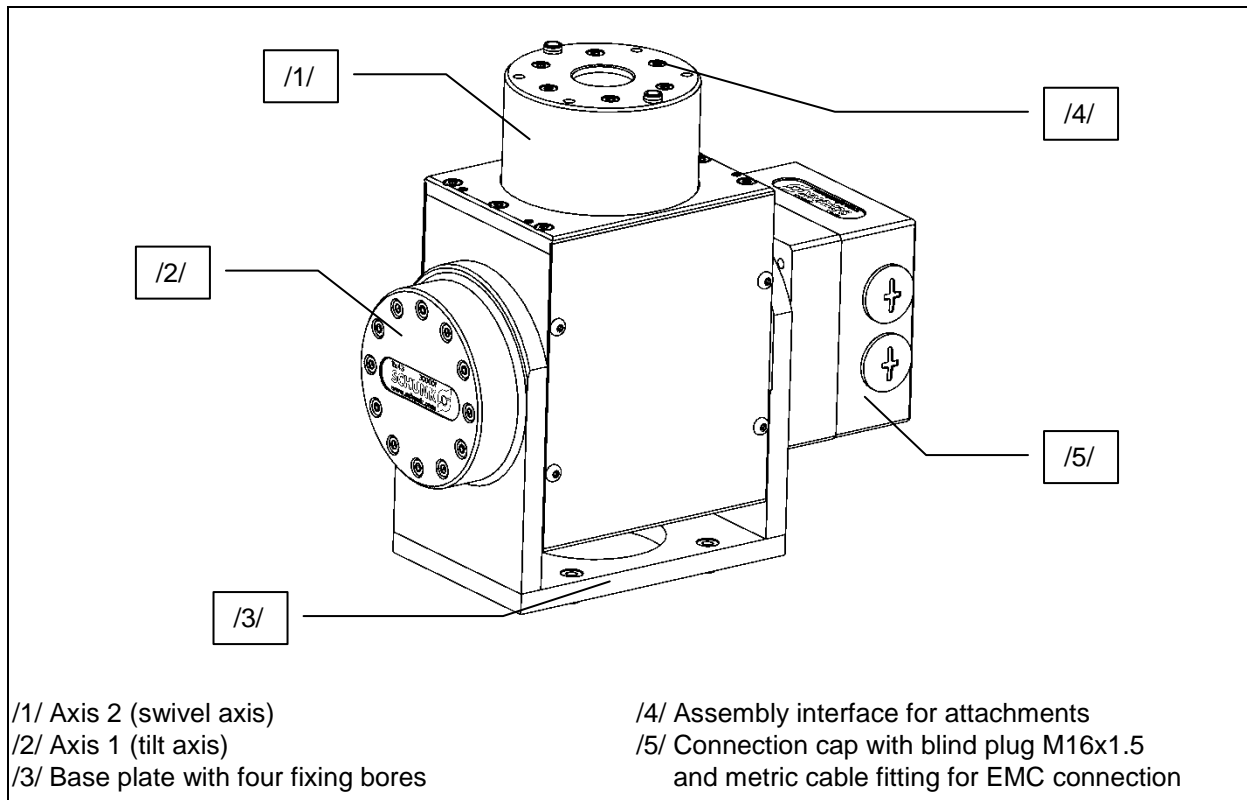

Figure 2 Servo-electric rotary pan-tilt actuator

Note

Only tilt axis (Axis 1) can be controlled via DIO's.

7.2 Functional principle

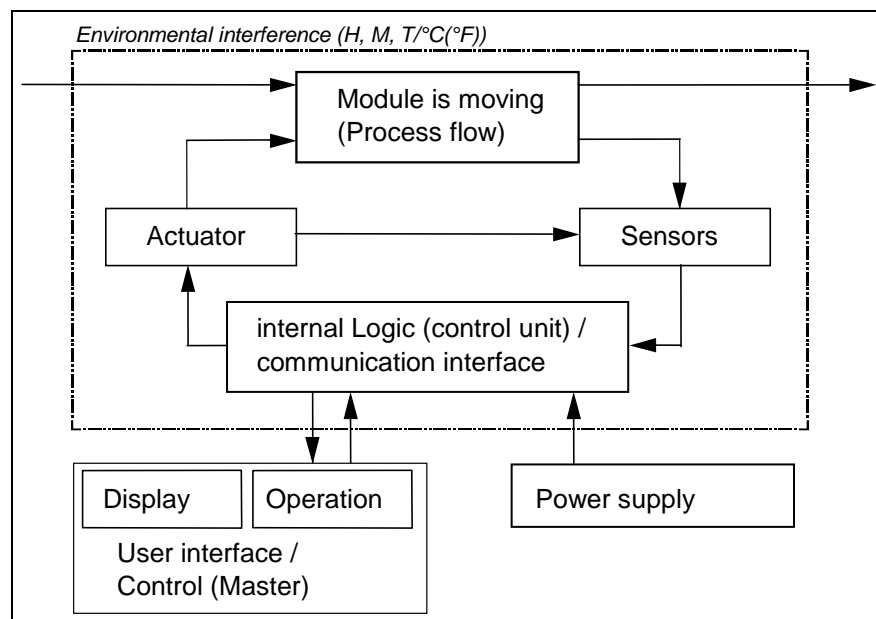

Figure 3

The actuator (in this case a DC motor per axis) is controlled by the internal logic. The required parameters are transferred from the higher level controller (master) to the internal logic.

The following parameters can be transferred from the controller (master) to the internal logic:

- Current I ;
- Velocity v ;
- Acceleration a
- Position

Notes

All possible parameters and the relevant features of the individual bus systems are described in more detail in the document about the SCHUNK Motion protocol (see DVD, document: MotionControl.pdf).

7.3 Connection cap board

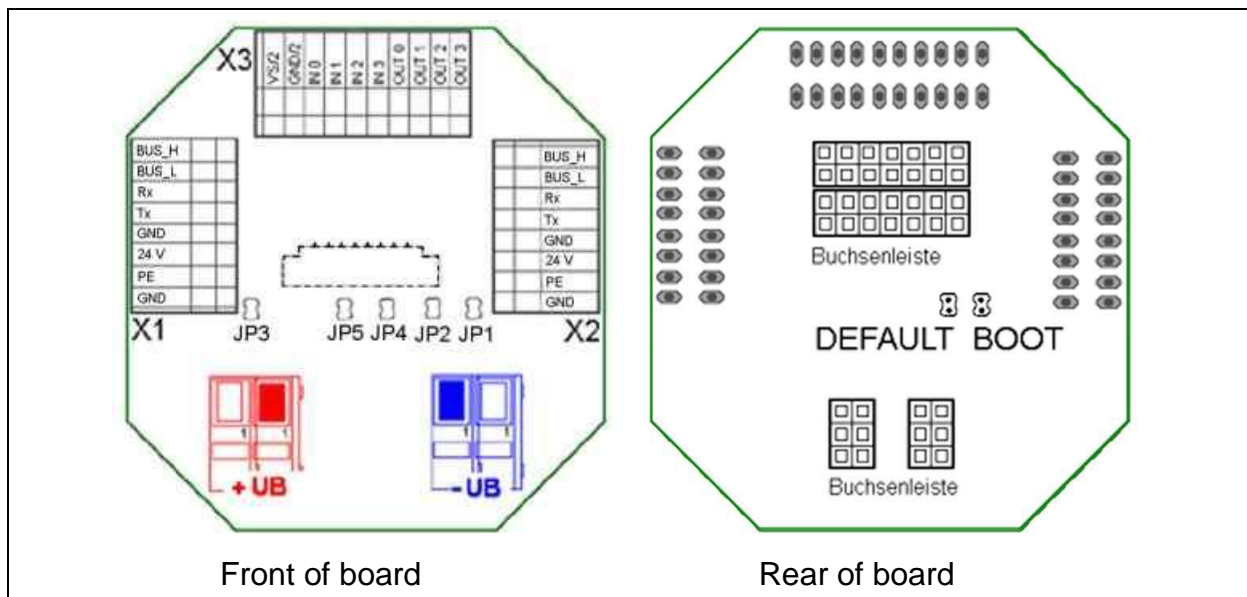

Figure 4

On the front of the board (connection side) are the connecting terminals X1, X2 and X3. The individual jumper connectors (JP1-JP5) for each interface and the motor output (+UB, -UB) are also located here.

Function of terminals:

- X1 is the main connecting terminal for the module's communication
- X2 is for the links to other modules
- X3 is for the use of digital inputs and outputs. Additional sensors can be connected here. The assignment of this terminal is independent of the interfaces.

On the rear of the board (plug-in side to module) are the socket strips and the jumper connectors for the "BOOT" and "DEFAULT" functions. (see chapter 8.3.5, page 30)

8 Assembly and commissioning

8.1 Mechanical Connection

⚠ WARNING

Risk of injury when the machine/system moves unexpectedly!

➔ Switch off energy supply.

- ✓ The installation position of the module has been designed so that cable wrapping is not possible.
- ➔ Use suitable connecting elements (adapter plate) to connect the module in the machine / system.
- ➔ Observe the permissible length of engagement.
- ➔ Observe the tightening torque of the screws.

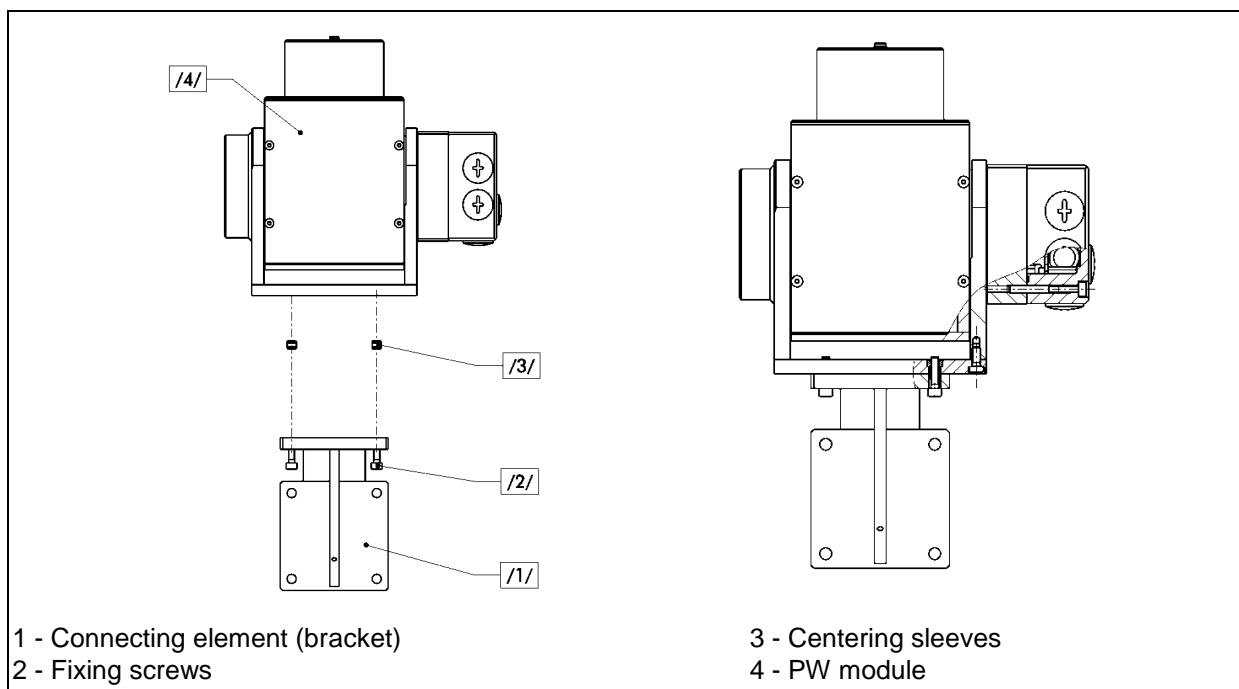

Figure 5 Mounting of the module

The customer must provide the following fixing materials:

Item	Fixing material	PW 70		PW 90	
		Base plate	Axis 2	Base plate	Axis 2
/2/	Permissible screws	4x M4	6x M4	6x M5	4x M5

Table 8 Fixing material (provided by customer)

8.2 Example of mounting

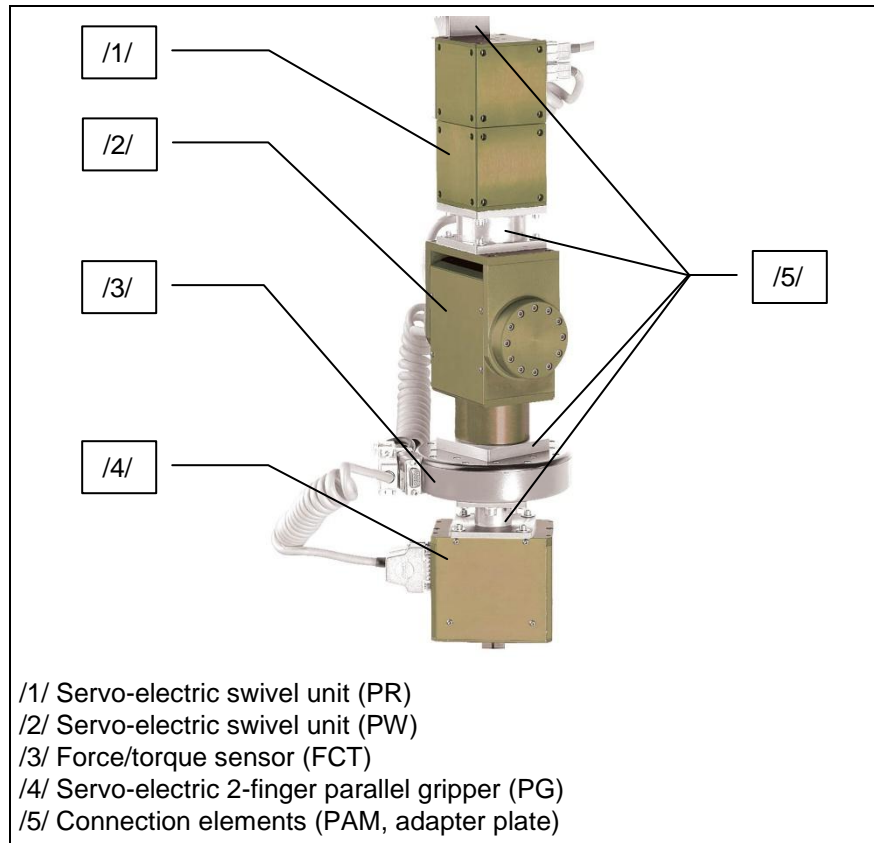

Figure 6

8.3 Electrical connection

Notes

The cable color throughout this chapter relates to the use of a SCHUNK connecting cable.

! NOTICE

Damage of electronics is possible!

In case of a high payload, dynamic energy may build up.

➔ The customer has to take care that the dynamic energy will be discharged.

We recommend to use our brake chopper
(Type: ACC3EA001 Id-No. 9951 504)

8.3.1 EMV-fitting

⚠ WARNING

Risk of injury when the machine/system moves unexpectedly!

➔ Switch off energy supply.

! NOTICE

Damage to board if screws are too tight!

➔ Only fix the screws in place on the board.

Notes

Observe the maximum electrical energy values.
(see chapter 6, page 13)

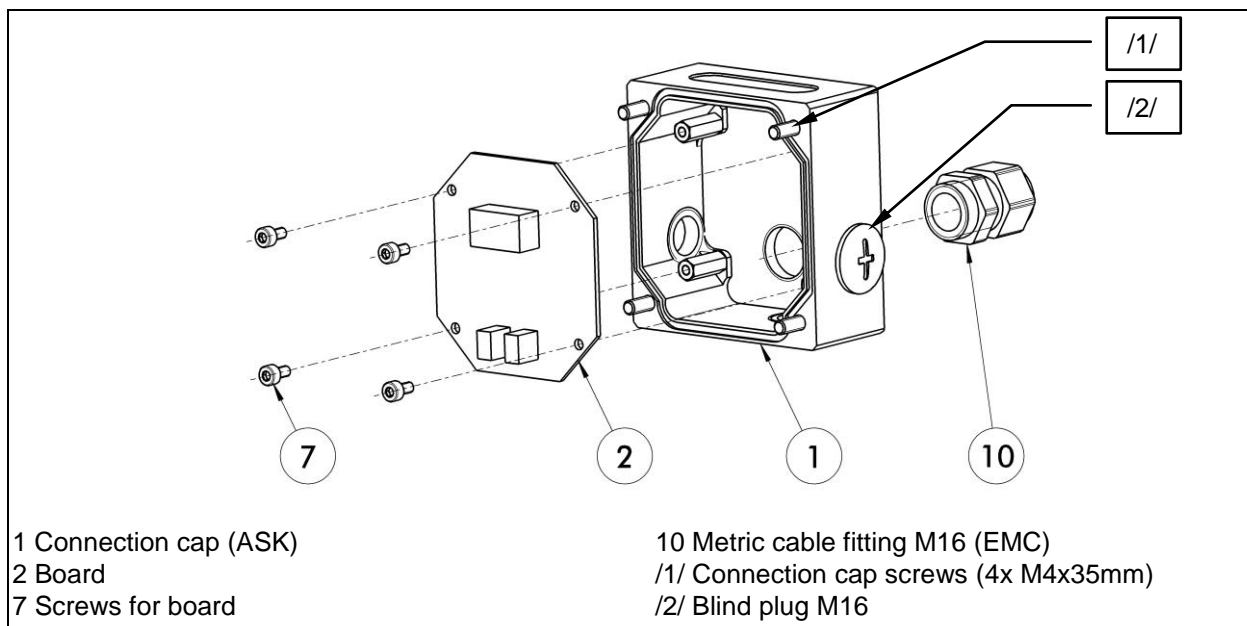

Figure 7

EMC fitting

The module is delivered without connection cap ASK. It can be ordered separately as accessory.

Connection cap ASK is necessary for operation.

(for item, see Figure 7, page 20)

1. Loosen the screws (/1/) for the connection cap (1) with a hexagon socket wrench (size 3).
2. Detach the connection cap (1) from the module.
3. Carefully unscrew the screws (7) for the board (2) with a hexagon socket wrench (size 2.5).
4. Carefully remove the board (2) from the connection cap (1) and place it safely to one side.
5. Unscrew the blind plug (/2/) to achieve an optimum connecting cable position.
6. Pull the connecting cable through the metric cable fitting (10).
7. Strip approximately 50mm from the connecting cable.
8. Strip around 5 mm of the individual wires, sufficient for the terminals.
9. Push the outer connecting cable shielding back over the cable sheath.
10. Fix the shielding in place with shrink hose in such a way that the shielding remains visible at the end of the sheath. (see Figure 8, page 22)
11. Pull the connecting cable through the connection cap (1) and connect the board (2) according to the required interface. (see chapter 8.3.2, page 23)
12. Pull the metric cable fitting (10) over the shrink hose so that the individual wires are still visible. (see Figure 8, page 22)
13. Screw metric cable fitting (10) onto connection cap (1).
14. Carefully slide the board (2) back into the connection cap (1).
15. Carefully tighten the screws (7) on the board (2).

16. Replace the connection cap (1) on the module and tighten the screws (/1/) to a maximum of 3 Nm.

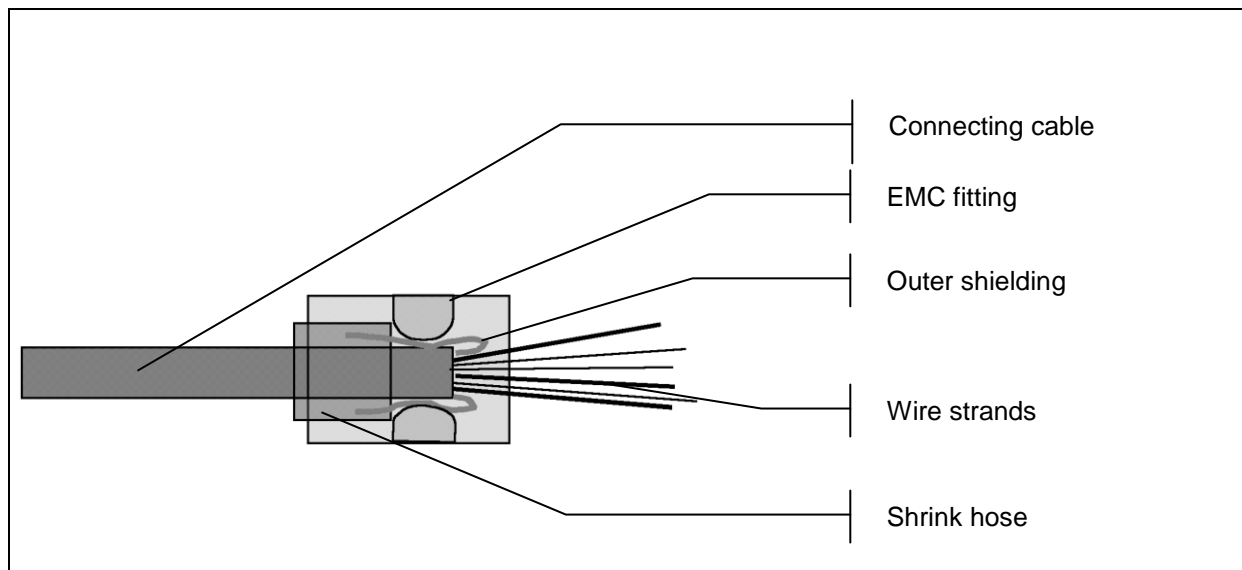

Figure 8 EMC fitting

8.3.2 RS232 interface

The communication interface RS232 can't be used as a field bus system because of its properties.

→ The RS232 interface should be only used as a parameterization interface.

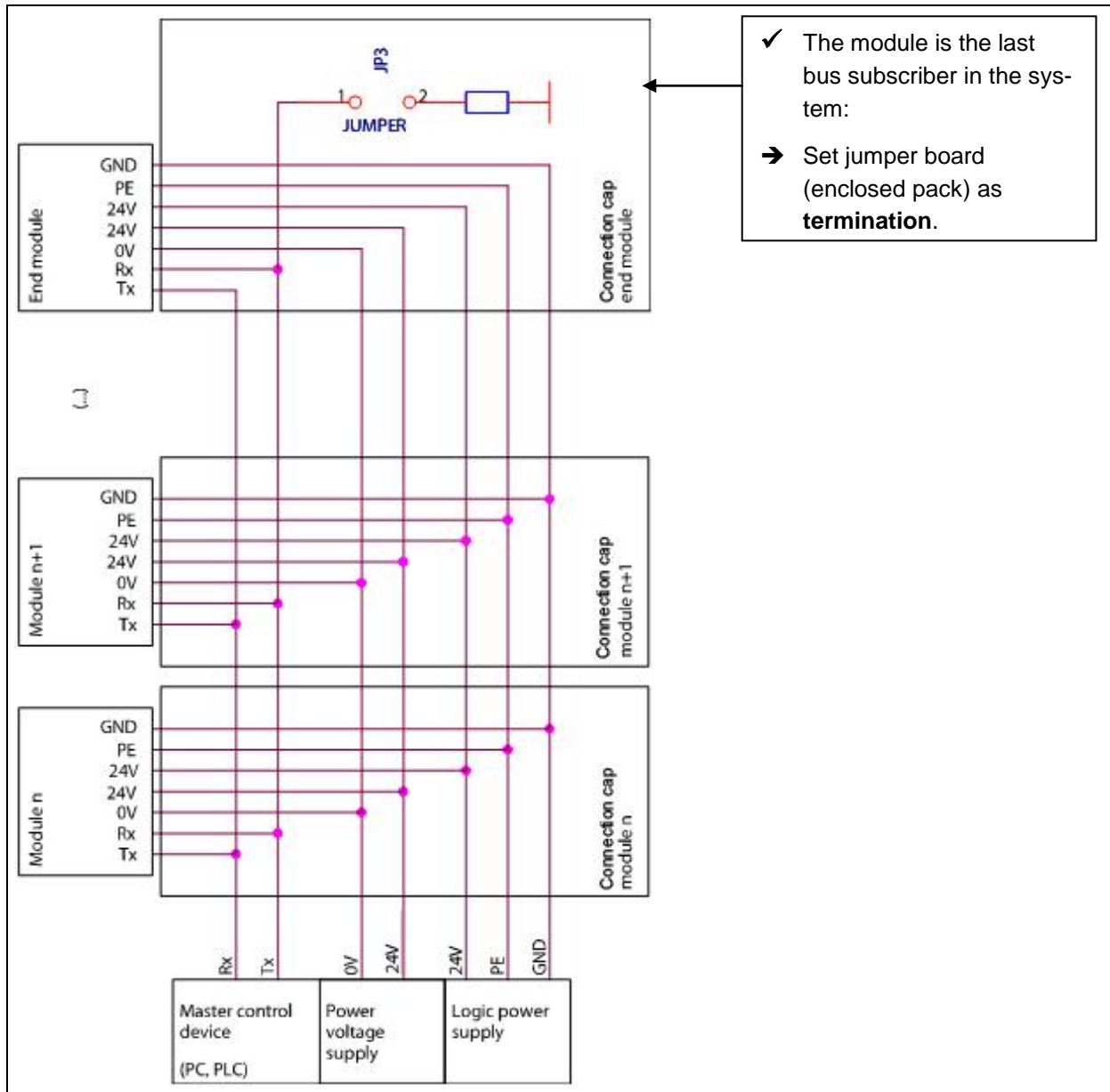

Figure 9 RS232 circuit diagram

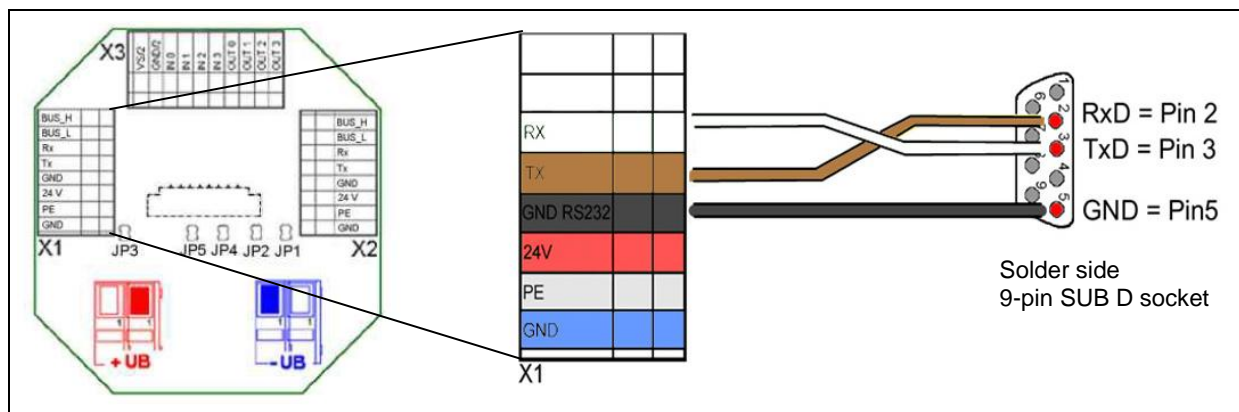

Figure 10 Connection board: Terminal strip X1 and connection to 9-pin SUB D socket

Connection	Terminal	SCHUNK cable color	
RS232 interface	Tx	brown	
	Rx	white	
	GND (Rx/Tx)	black (from Rx/Tx)	
Logic connection	24V	red	0,25 mm ²
	GND	blue	0,25 mm ²
Output power supply	+UB	red	2,5 mm ²
	-UB	blue	2,5 mm ²

Table 9 RS232 connection: Assignment of terminal strip X1

Combining several modules

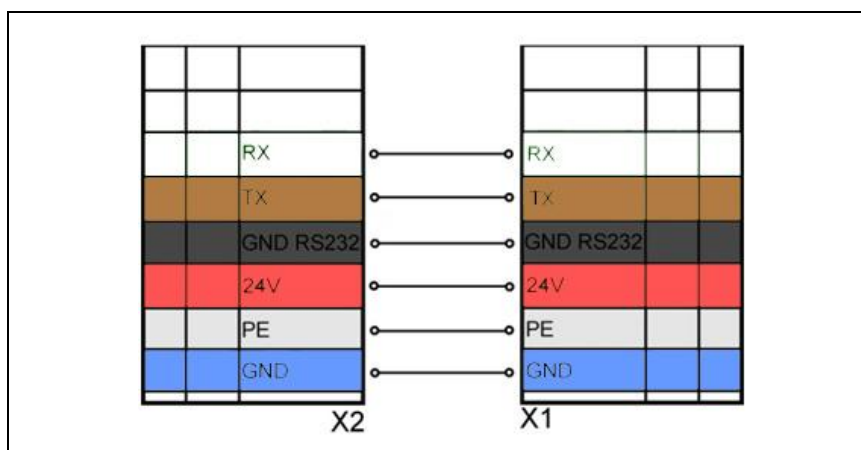

Figure 11 Combining module n with module n+1

When combining several modules, the signals from module n are looped through to module n+1. The wires from terminal X2 on module n are connected to terminal X1 on module n+1.

8.3.3 CAN interface

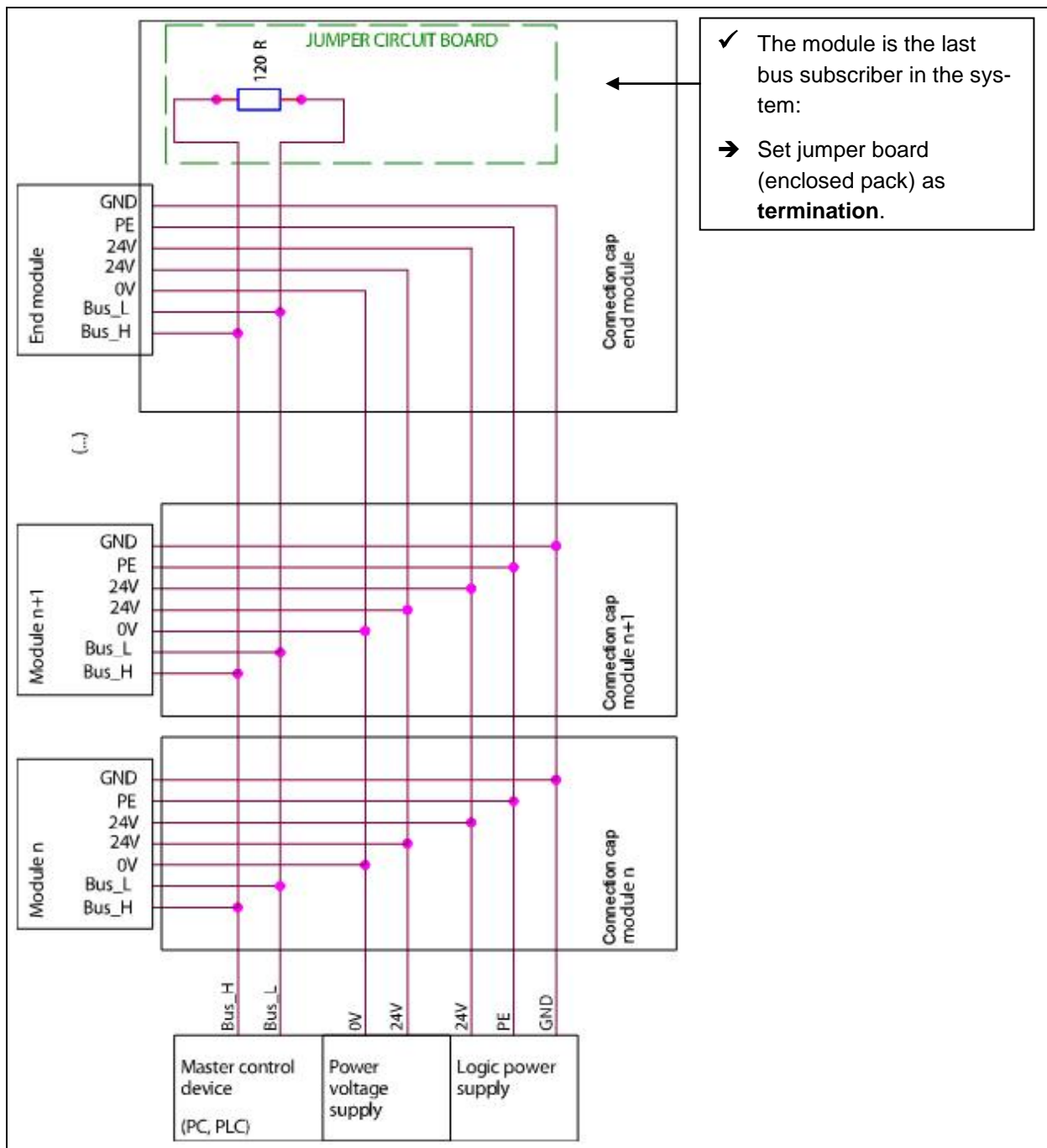

Figure 12 CAN circuit diagram

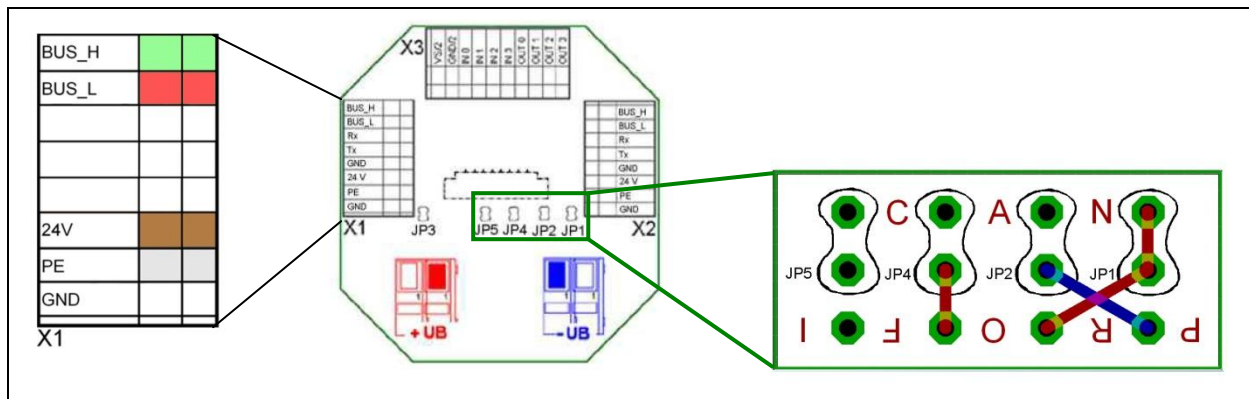

Figure 13 Connection board: Terminal strip X1 and jumper board for termination

Until 2010-12

Connection	Terminal	SCHUNK cable color	
CAN interface	Bus_H	yellow	
	Bus_L	green	
	PE	shield	
Logic connection	24V	brown	0,25 mm ²
	GND	white	0,25 mm ²
Output power supply	+UB	red	2,5 mm ²
	-UB	blue	2,5 mm ²

Table 10 CAN connection Assignment of terminal strip X1

From 2011-01

Connection	Terminal	SCHUNK cable color	
CAN interface	Bus_H	white	
	Bus_L	red	
	PE	shield	
Logic connection	24V	red	0,25 mm ²
	GND	blue	0,25 mm ²
Output power supply	+UB	red	2,5 mm ²
	-UB	blue	2,5 mm ²

Table 11 CAN connection Assignment of terminal strip X1

SUB D socket solder side	Pin	Terminal
	2	Bus_L
	7	Bus_H

Table 12 CAN assignment of 9-pin SUB D socket

Combining several modules

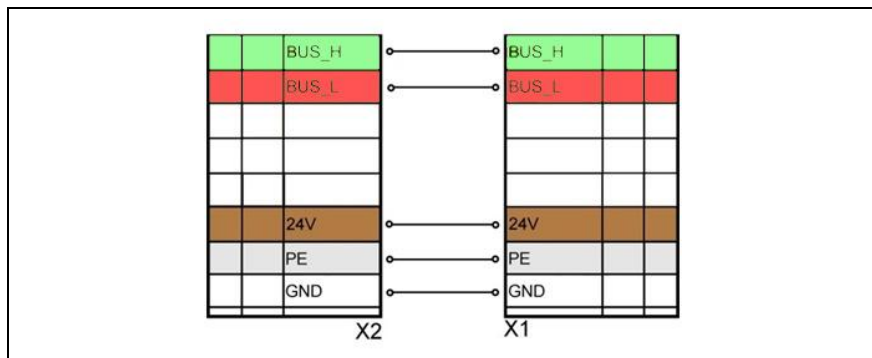

Figure 14 Combining module n with module n+1

When combining several modules, the signals from module n are looped through to module n+1. The wires from terminal X2 on module n are connected to terminal X1 on module n+1.

8.3.4 Interface PROFIBUS DP

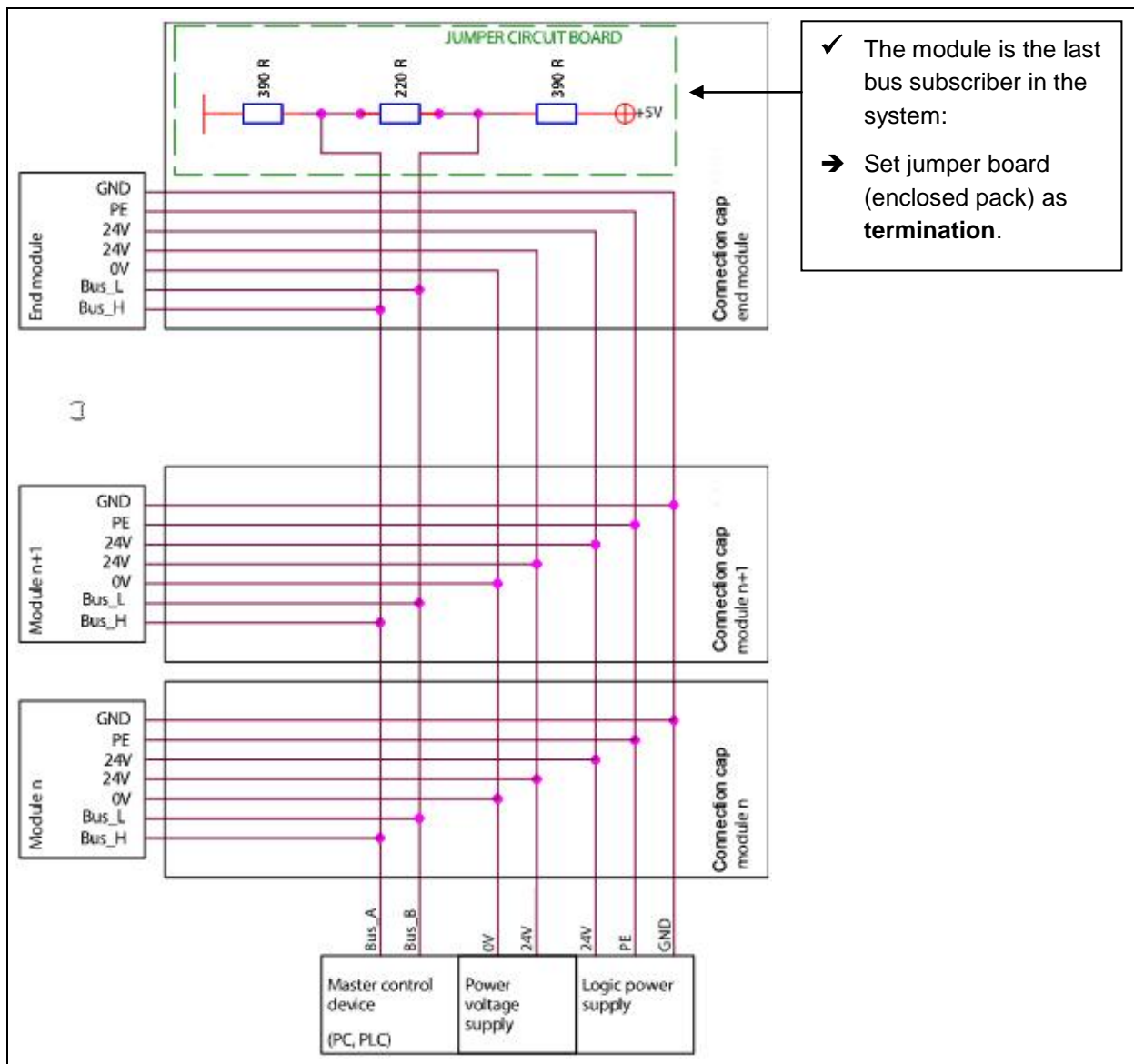

Figure 15 PROFIBUS DP circuit diagram

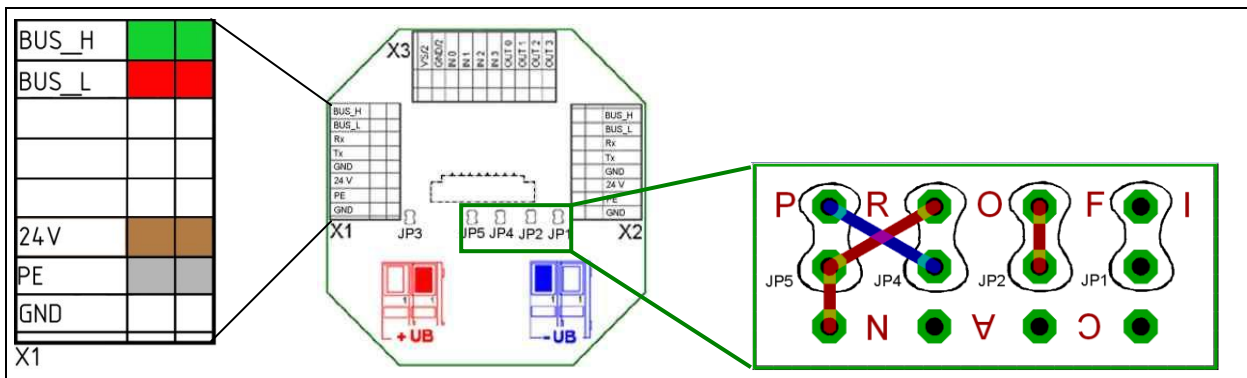

Figure 16 Connection board: Terminal strip X1 and jumper board for termination

Connection	Terminal	SCHUNK cable color	
PROFIBUS DP interface (cable 1)	Bus_H (Bus_A)	green	
	Bus_L (Bus_B)	red	
	PE	shield (from cable 1 & 2)	
Logic connection (cable 2)	24V	brown	0,25 mm ²
	GND	white	0,25 mm ²
Output power supply	+UB	red	2,5 mm ²
	-UB	blue	2,5 mm ²

Table 13 CAN connection Assignment of terminal strip X1

SUB D socket solder side	Pin	Terminal X1
	3	Bus_L (Bus_B)
	8	Bus_H (Bus_A)

Table 14 PROFIBUS DP assignment of 9-pin SUB D connector

Combining several modules

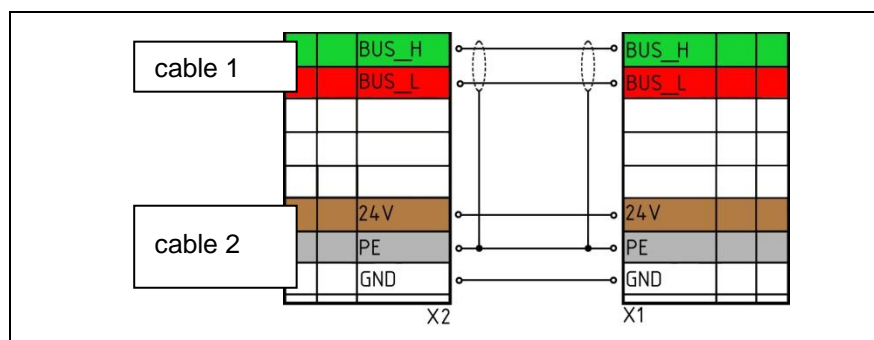

Figure 17 Combining module n with module n+1

When combining several modules, the signals from module n are looped through to module n+1. The wires from terminal X2 on module n are connected to terminal X1 on module n+1.

8.3.5 DEFAULT and BOOT function

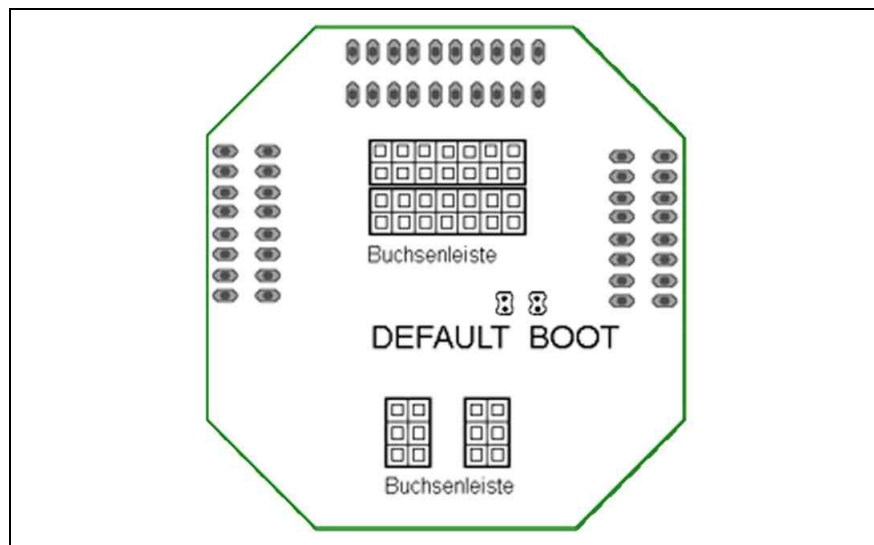

Figure 18 Connection board: Rear

Setting the module to factory settings

The module can be reset to the factory settings using the DEFAULT function:

1. Turn off the power supply.
2. Unscrew the four screws (M4 x 35mm) for the connection cap using a hexagon socket wrench (size 3).
3. Detach the connection cap from the module.
4. Place the jumper (enclosed pack) at the DEFAULT connector on the connection board.
5. Reconnect the connection cap to the module.
6. Turn on the power supply for around 10 seconds.
7. Turn off the power supply and detach the connection cap from the module.
8. Disconnect the jumper from the DEFAULT connector.
9. Reconnect the connection cap to the module.
10. Tighten the connection cap screws uniformly.

The module is now set to the DEFAULT values.
(see chapter 6.2, page 14)

**Loading new
firmware to the
module****Applicable for firmware 1.3.x till 15.04.2010:**

New firmware can be loaded to the module using the BOOT function:

- ✓ RS232 communication interface is connected and active. (see chapter 8.3.2, page 23)
- 1. Turn off the power supply.
- 2. Unscrew the four screws (M4 x 35mm) for the connection cap using a hexagon socket wrench (size 3).
- 3. Detach the connection cap from the module.
- 4. Place the jumper (enclosed pack) at the BOOT connector on the connection board.
- 5. Reconnect the connection cap to the module.
- 6. Turn on the power supply again.
- 7. The module is in BOOT mode. New firmware is transferred to the module using the MCDemo tool (see MotionControl.pdf)
- 8. Turn off the power supply.
- 9. Detach the connection cap from the module.
- 10. Disconnect the jumper from the BOOT connector.
- 11. Reconnect the connection cap to the module.
- 12. Tighten the connection cap screws uniformly.

Notes

For further information, refer to the MotionControl.pdf document on the DVD supplied.

Applicable for firmware 1.4.x from 16.04.2010:

Module can be overwritten with a new firmware by the function „Modul“ – „Firmware update“ of the software MCDemo (included on the provided CD).

Note

Versions of software and firmware need to be adapted to each other.

8.4 System integration

8.4.1 System structure

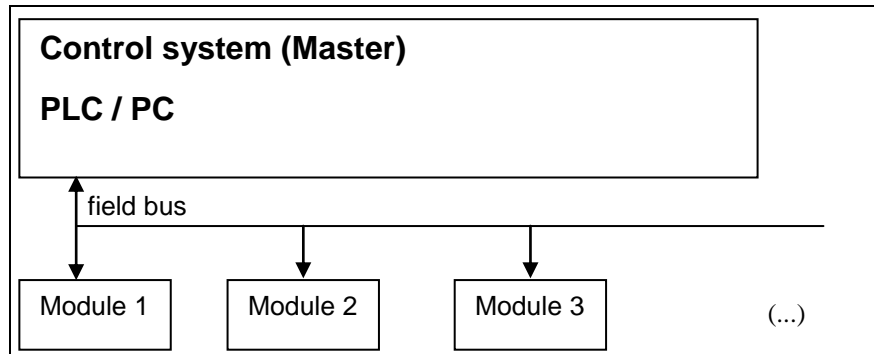

Figure 19

Data format

The data is transferred in INTEL Format (Little Endian Format).

Notes

The number of modules connected depends on the bus used. A maximum of 255 IDs can be assigned (see DVD, Document: MotionControl.pdf).

8.4.2 SCHUNK Motion protocol

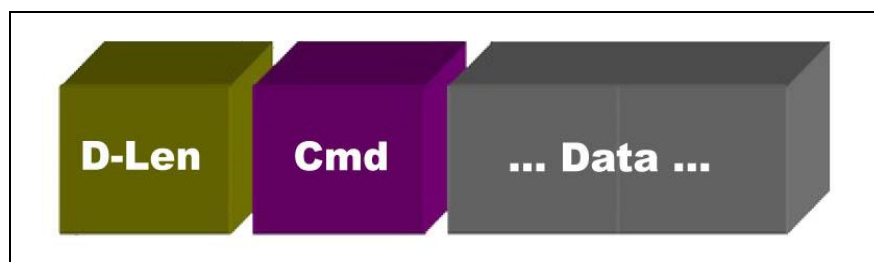

Figure 20

The data frame of the Motion protocol always includes the following elements:

- D-Len (1-byte)
- Command Code (1 byte)

D-Len (Data Length) specifies the number of subsequent items of user data including the command byte. The data

frame consists of one byte, therefore a Motion protocol message can transfer a maximum of 255 data bytes.

The D-Len byte is always followed by the command code, consisting of one byte. If necessary, the command code is followed by the relevant parameters required. If required, a "master command" can be extended with a "sub-command".

All commands sent are immediately confirmed by the module with a response (acknowledge). This response also uses the data frame described above (D-Len, command code, any parameters). If the request has been successfully processed, D-Len always has a value that is not equal to "0x02". If the request failed, D-Len has the value "0x02".

Notes

The special features of the different bus systems are described in MotionControl.pdf (see DVD, Document: MotionControl.pdf).

8.4.3 Most important commands

DANGER

Risk of injury when the machine/system moves unexpectedly due to incorrect programming!

→ Only specialist personnel or specially trained staff should carry out settings and enter parameters.

Notes

In all examples, only the necessary parameters are listed, not the optional parameters. In the examples, "M" stands for master and "S" for slave (= module).

Referencing

Command Code: 0x92

Description: A referencing is executed.

Parameters (Master ⇌ Slave): None.

Response (Slave ⇌ Master): "OK" (0x4F4B) if successful.
The module executes the command.

Miscellaneous: Spontaneous response possible.

	D-Len	Cmd	Param	Meaning
M ⇌ S	0x01	0x92		
S ⇌ M	0x03	0x92	0x4F 0x4B	Successfully referenced

Table 15 Example for REFERENCE

Positioning

Command Code: 0xB0

Description: Moves the module to a specified position.

Parameters (Master ⇌ Slave):

- Position in configured unit system (must be specified)
- Velocity (optional)
- Acceleration (optional)
- Current (optional)
- Jerk (optional)

Response (Slave ⇌ Master): If possible, the time that the module needs for the movement is returned.

Miscellaneous: Spontaneous response when position reached or in case of prior termination of positioning.

	D-Len	Cmd	Param	Meaning
M ⇌ S	0x05	0xB0	0x00 0x00 0x20 0x41	Move to position 10.0[mm]
S ⇌ M	0x05	0xB0	0xCD 0xCC 0x04 0x41	Will reach position in 8.3[sec]

Table 16 Example for MOVE POS

Current move

Command Code: 0xB3

Beschreibung: A current move is executed.

Parameters (Master ⇒ Slave):

Current in configured unit system (must be specified).

Response (Slave ⇒ Master): "OK" (0x4F4B) if successful.
The module executes the command.

Miscellaneous: Spontaneous message is possible.

	D-Len	Cmd	Param	Meaning
M ⇒ S	0x05	0xB3	0x00 0x00 0x60 0x40	Execute current move with 3.5[A]
S ⇒ M	0x05	0xB3	0x4F 0x4B	

Table 17 Example for MOVE CUR

Velocity move

Command Code: 0xB5

Description: A velocity move is executed.

Parameters (Master ⇒ Slave):

- Velocity in configured unit system (must be specified)
- Current (optional)

Response (Slave ⇒ Master): "OK" (0x4F4B) if successful.
The module executes the command.

Miscellaneous: Spontaneous message is possible if the module is no longer moving.

	D-Len	Cmd	Param	Meaning
M ⇒ S	0x05	0xB5	0x9A 0x99 0x31 0x41	Execute velocity move with 11.1[mm/s]
S ⇒ M	0x05	0xB5	0x4F 0x4B	

Table 18 Example for MOVE VEL

Stop module

Command Code: 0x91

Description: The module is braked and stopped in the current position.

Parameters (Master ⇌ Slave): None.

Response (Slave ⇌ Master): "OK" (0x4F4B) if successful.

Miscellaneous: Spontaneous message is possible.

	D-Len	Cmd	Param	Meaning
M ⇌ S	0x01	0x91		
S ⇌ M	0x03	0xB5	0x4F 0x4B	OK

Table 19 Example for CMD STOP

Emergency stop

Command Code: 0x90

Description: The module is stopped as quickly as possible. If a brake is fitted and appropriately configured, it is activated immediately. The motor phases are short circuited.

Parameters (Master ⇌ Slave): None.

Response (Slave ⇌ Master): Error message "ERROR EMERGENCY STOP" is triggered.

Miscellaneous: Can only be reset by "CMD ACK".

	D-Len	Cmd	Param	Meaning
M ⇌ S	0x01	0x90		
S ⇌ M	0x03	0x88	0xD9	Emergency stop executed

Table 20 Example for CMD EMERGENCY STOP

Acknowledge error

Command Code: 0x8B

Description: Acknowledgement of an error message.

Parameters (Master ⇌ Slave): None.

Response (Slave ⇌ Master): "OK" (0x4F4B)

Miscellaneous: When all errors have been successfully acknowledged, after sending "OK" (0x4F4B), an info message "INFO NO ERROR" is also sent.

	D-Len	Cmd	Param	Meaning
M ⇌ S	0x01	0x8B		
S ⇌ M	0x03	0x8B	0x4F 0x4B	OK

Table 21 Example for CMD ACK

Notes

For further information, refer to the MotionControl.pdf document on the DVD supplied.

9 Troubleshooting

9.1 Module does not move

Possible causes	Remedial measures
Communication with the module is not possible	➔ Check bus connection (see chapter 8.3, page 19)

Table 22

9.2 The module is sluggish or jerky

Possible causes	➔ Remedial measures
Dirt deposits in the cavities	➔ Clean the module (see chapter 10.1, Page 39)

Table 23

9.3 The module's motor is not turning

Possible causes	➔ Remedial measures
No voltage connected	➔ Check the power supply
Insufficient voltage	➔ Check the power supply requirements. (see chapter 6.3, Page 14)

Table 24

9.4 Module stops abruptly

(This can be reported by the module using the **ERROR_CABLE_BREAK (0x76)** parameter if the GSD file supplied has been integrated.)

Possible causes	Remedial measures
Bus cable fault (connection to module broken)	➔ Check bus cable for damage and replace if necessary. ➔ For more troubleshooting, see MotionControl.pdf.

Table 25

10 Maintenance and care

10.1 Maintenance intervals

⚠ WARNING

Risk of injury when the machine/system moves unexpectedly!

➔ Switch off energy supply.

Size	70	90
Interval [Mio. Cycles]	2	2

Table 26

The module complies with protection class IP 54 with mounted connection cap DMI.

- ➔ Clean the module dry, remove all coarse dirt and chips from the cavities on the module.
- ➔ Check for damage and replace the module if necessary.

Any repair work on the module may only be carried out by SCHUNK.

- ➔ Call the service hotline or your SCHUNK contact
- ➔ Send the module to SCHUNK with a repair request.

10.2 Dismantling the module

The module may only be dismantled by SCHUNK as otherwise the mechanism or internal electronics may be damaged.

11 EC declaration of incorporation

In terms of the EC Machinery Directive 2006/42/EC, annex II B

Manufacturer/
distributor SCHUNK GmbH & Co. KG.
 Spann- und Greiftechnik
 Bahnhofstr. 106 – 134
 74348 Lauffen/Neckar, Germany

We hereby declare that the following product:

Product designation Servo-electric rotary pan-tilt actuator
Type designation: PW 70, 90, 90-B2
ID number: 0307340, 307342, 0306618

meets the applicable basic requirements of the Directive **Machinery (2006/42/EC)**.

The incomplete machine may not be put into operation until conformity of the machine into which the incomplete machine is to be installed with the provisions of the Machinery Directive (2006/42/EC) is confirmed.

Applied harmonized standards, especially:

EN ISO 12100-1 Safety of machines - Basic concepts, general principles for design --
 Part 1: Basic terminology, methodology
EN ISO 12100-2 Safety of machines - Basic concepts, general principles for design --
 Part 2: Technical principles

The manufacturer agrees to forward on demand the special technical documents for the incomplete machine to state offices.

The special technical documents according to Annex VII, Part B, belonging to the incomplete machine have been created.

Person responsible for documentation:

Mr. Uwe Heinz. Address: see manufacturers address

Location, date/signature: Lauffen, Germany, January 2011

ppa. 

Title of the signatory

Director for Development