

# VERO-S NSR

Robot coupling for high-end pallet handling

Superior Clamping and Gripping



# Product Overview



## Gripping Systems

## Clamping Technology



Chuck Jaws



Lathe Chucks



Stationary Workholding



Toolholders



Hydraulic Expansion Technology



VERO-S



KONTEC



TANDEM



ROTA



MAGNOS



PLANOS

# Challenges

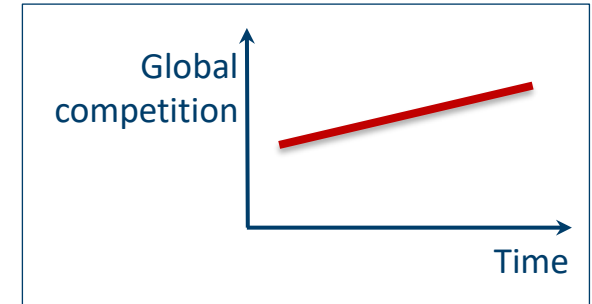
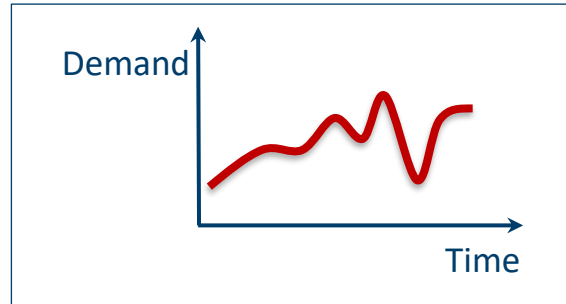
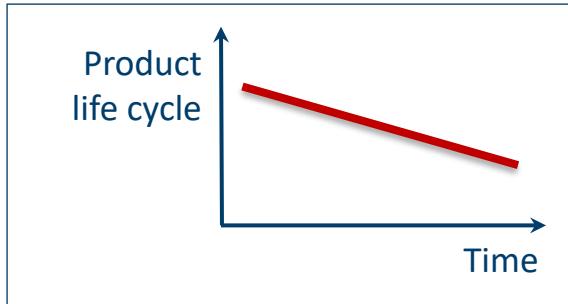
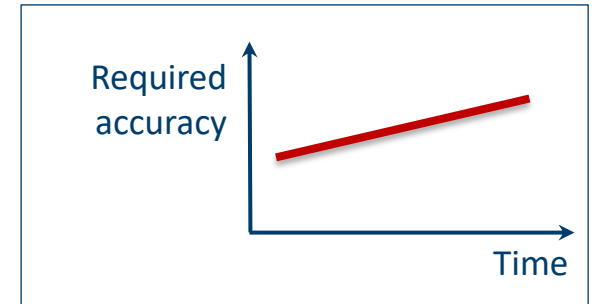
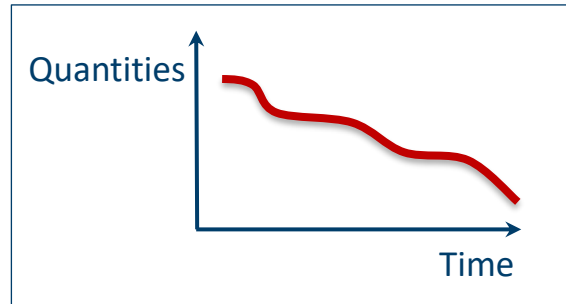
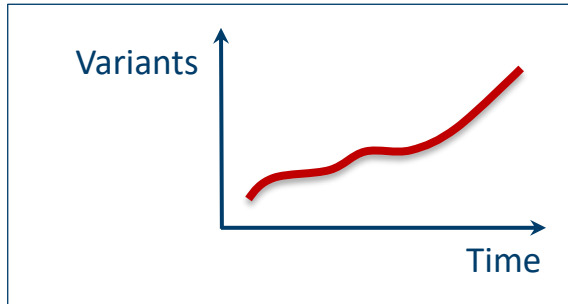

Increasing relevance of the set-up process

# Potential for savings

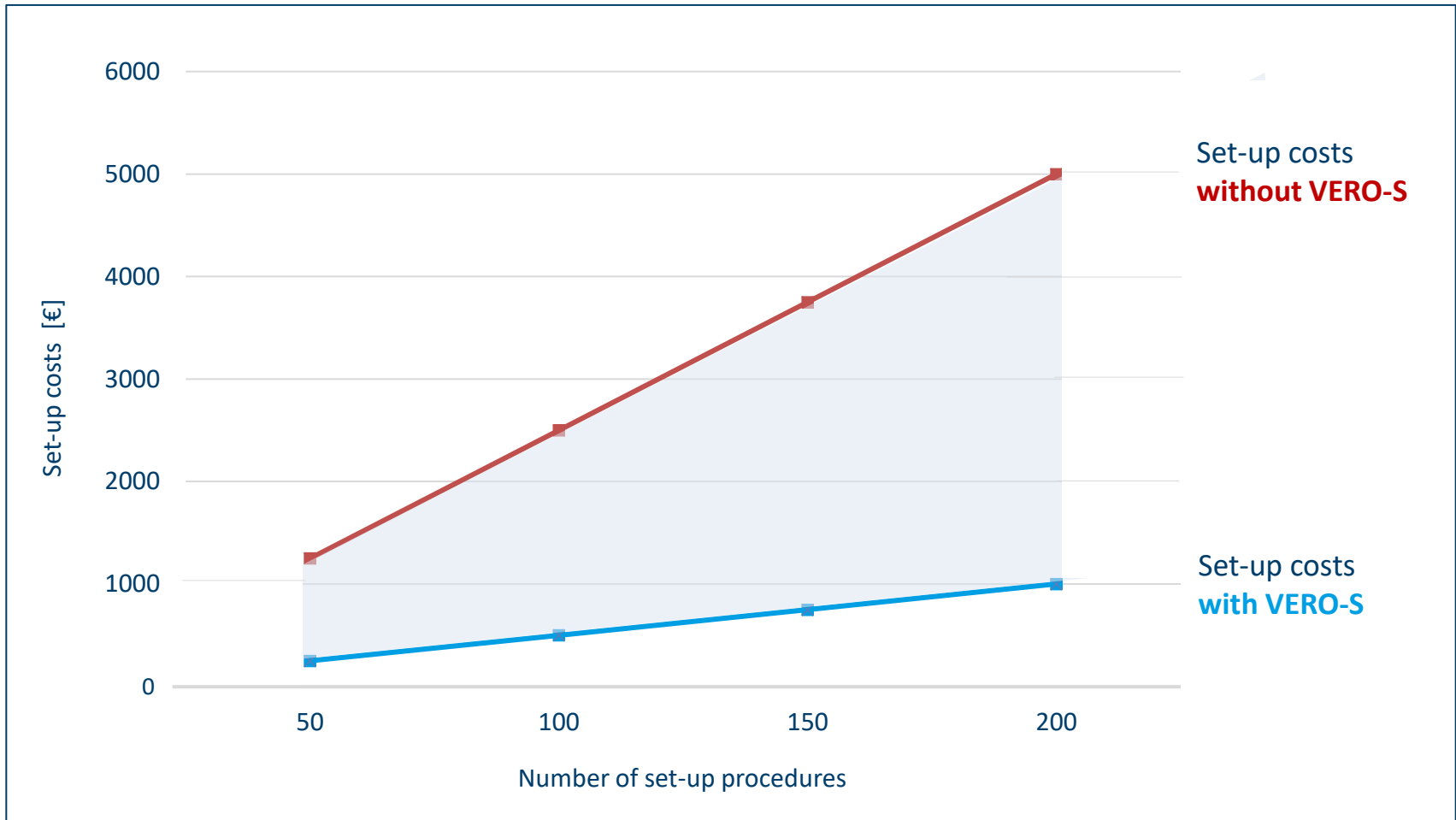

# Amortisation



Even for older machines, the investment in SCHUNK VERO-S quick change pallet system amortizes within a minimum of time.

Thanks to the consistent interface of the clamping pin, the existing clamping devices can easily be integrated in the new system.

Calculation for set-up costs	Case 1	Case 2
Investment in SCHUNK VERO-S [€]	5.000	10.000
Time per set-up procedure without VERO-S [min]	25	
Time per set-up procedure with VERO-S [min]	5	
Machine costs [€/h]	60	
Number of set-up procedures per day	5	
Working days per month	20	
Working days per year	240	
Payback Time		
Set-up procedures	250	500
Working days	50	100
Months	2,5	5
<b>Years</b>	<b>0,21</b>	<b>0,42</b>

# Consistency of pull-down and holding forces

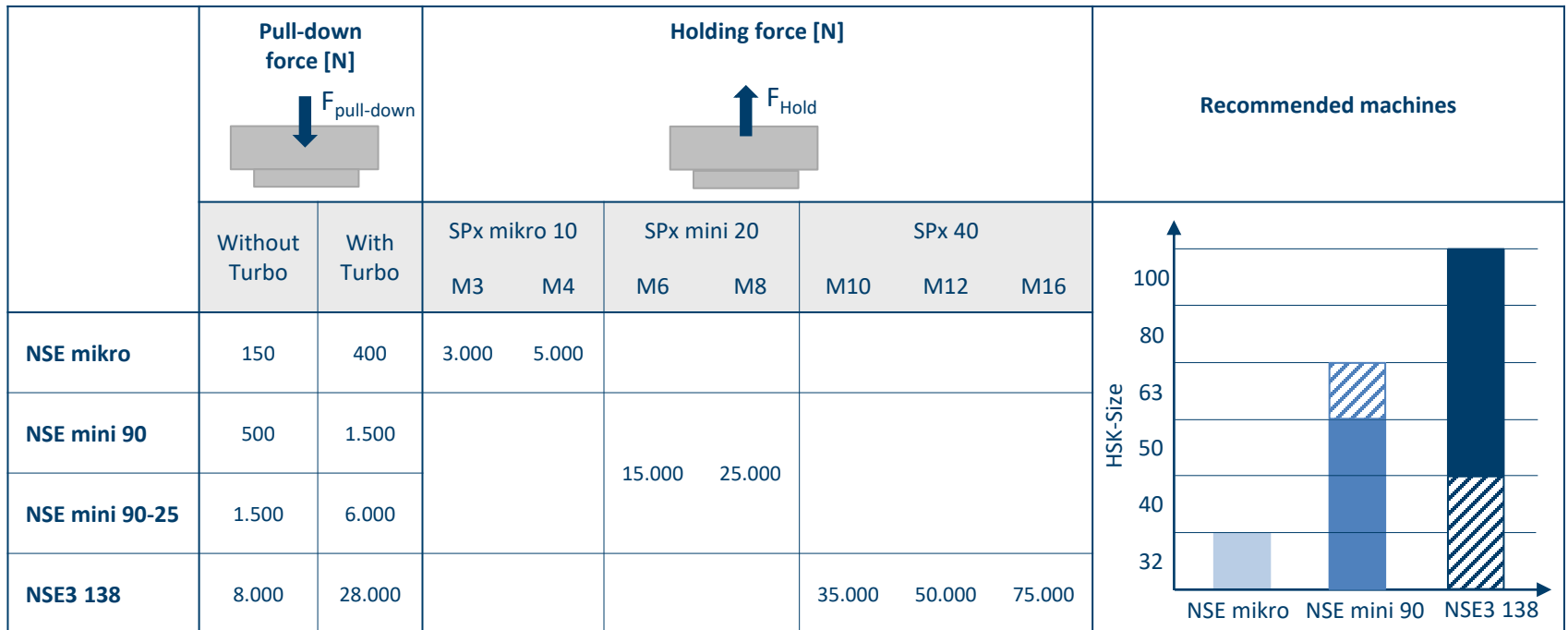



# VERO-S Overview

General milling applications

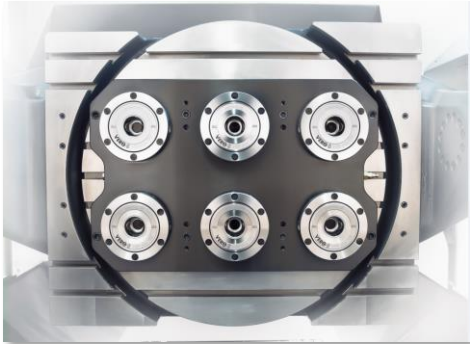

Direct workpiece clamping



Milling and turning applications

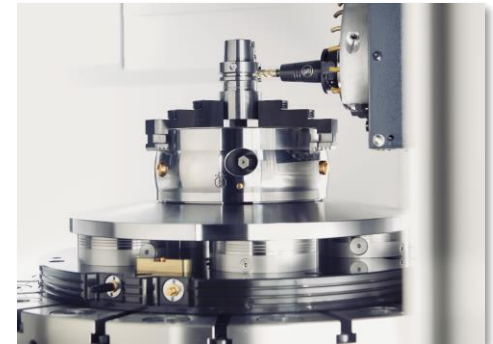

Easy milling applications

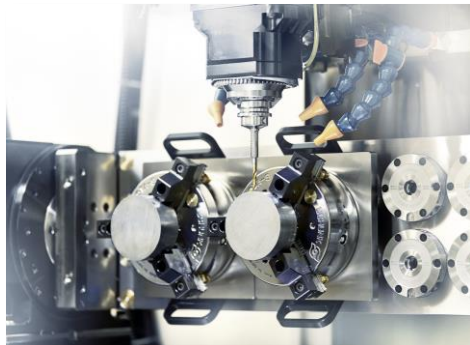

Automated machine loading

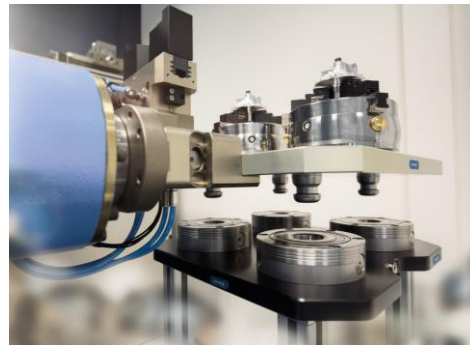

Further applications

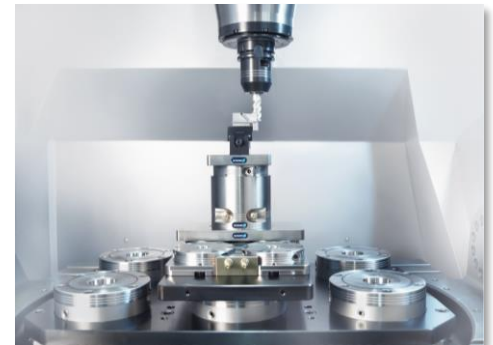

# VERO-S NSR

## Example of application

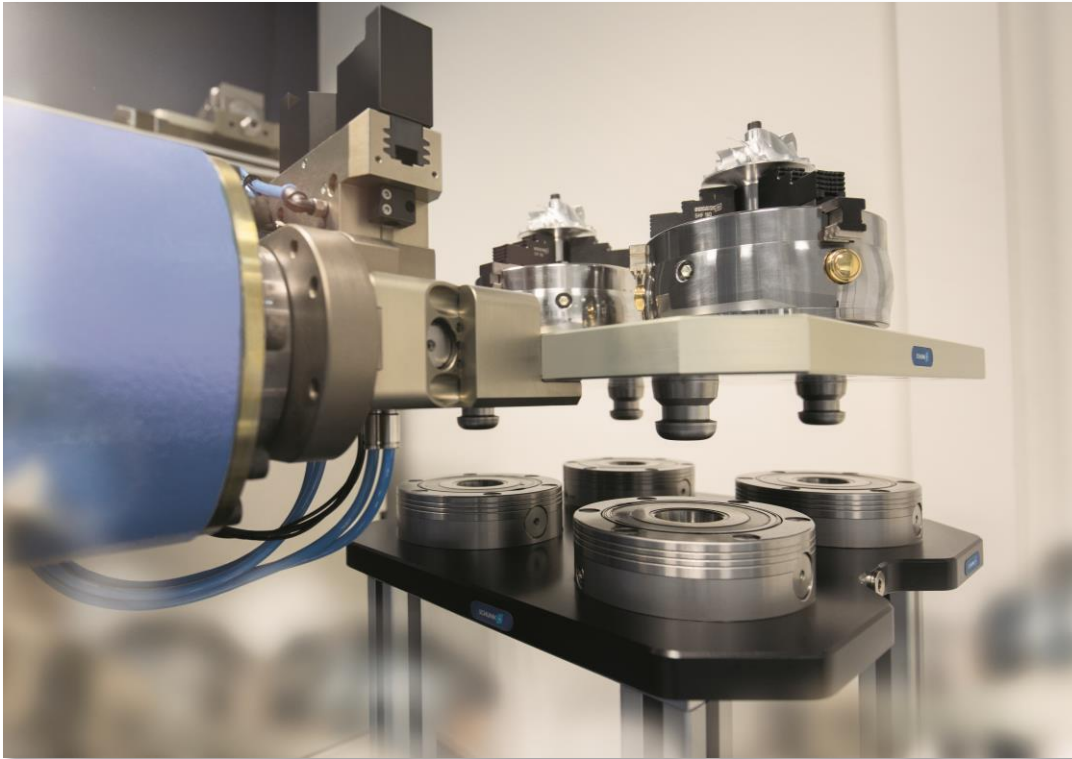

### VERO-S:

Clamping module NSE plus 138,  
Robot coupling NSR,  
Palett coupling PKL.

### Clamping device:

Manual chuck ROTA-S plus 2.0.

### Features/Application:

The high pull-down force of the NSR robot coupling enables the handling of extremely heavy pallets (up to 1000 kg with dimensions 800 x 800 mm). The slim construction of the PKL allows a low design of clamping station and clamping pallet.

# VERO-S NSR



STAINLESS  
STEEL

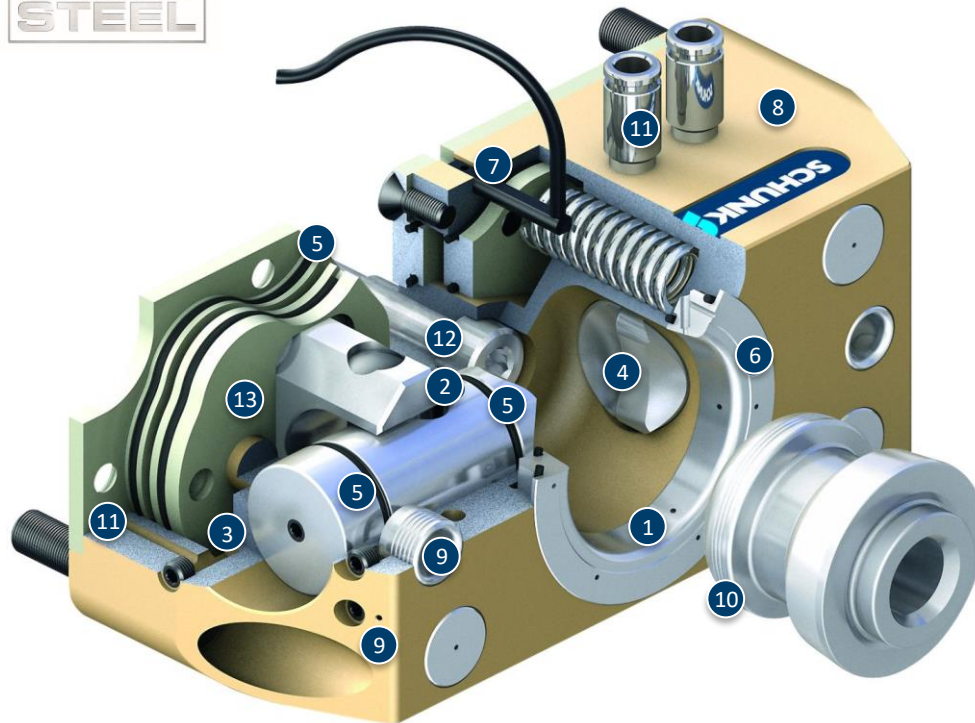

- ① High-precision short taper centering
- ② Patented dual stroke system
- ③ Turbo function
- ④ Large surfaces
- ⑤ Completely sealed system
- ⑥ Steel inlays with integrated cleaning function
- ⑦ Monitoring of the clamping slide position module opened and module closed
- ⑧ Weight-optimized design
- ⑨ Anti-twist protection
- ⑩ Entry radii on the clamping pin
- ⑪ Actuation of the module
- ⑫ Fitting screws
- ⑬ Pneumatic system

# VERO-S NSR

## Comparison: Pull-down force spring clamping and turbo function

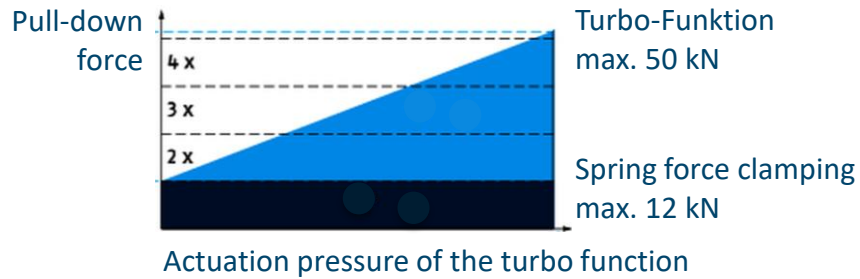

## Centering via short taper

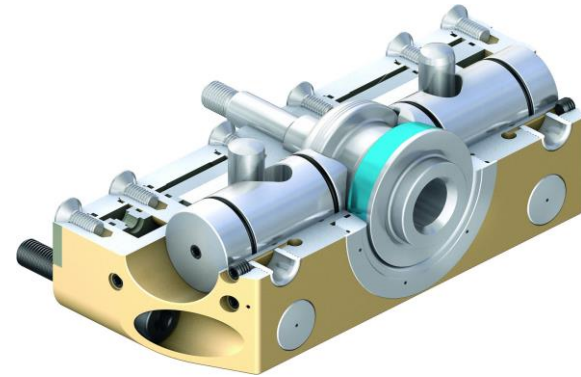

## Locking via clamping slide

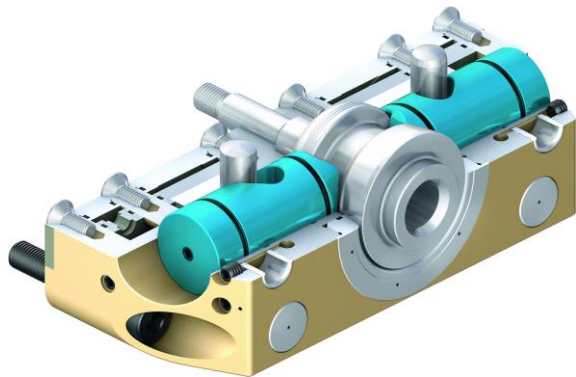

## Integrated turbo function

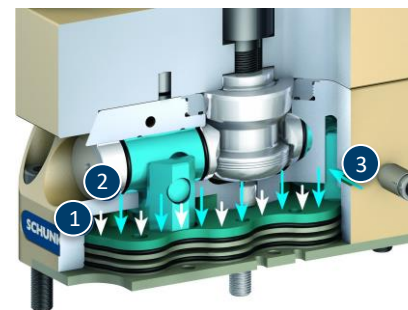

- 1 Spring force
- 2 Additional force, resulting from the turbo function
- 3 Turbo function connection

# VERO-S NSR

## Control of the robot coupling

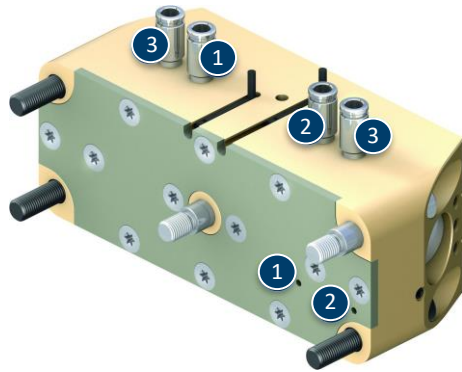

- 1 Open
- 2 Turbo function
- 3 Air purge

## Monitoring opened or clamped (optional)



Robot coupling opened

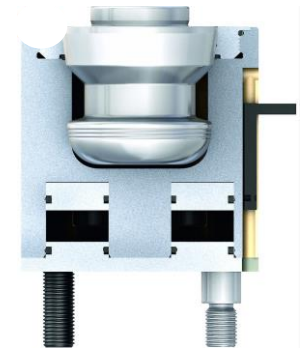

Robot coupling closed

## Monitoring of pallet presence (optional)

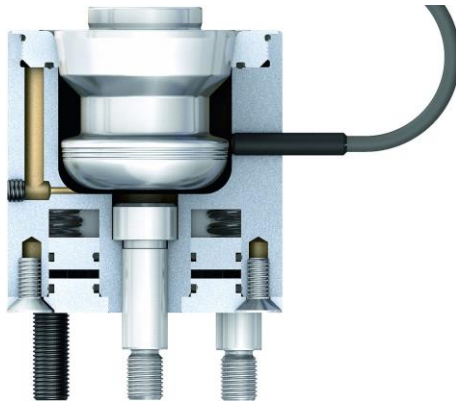

## Cleaning based on air purge

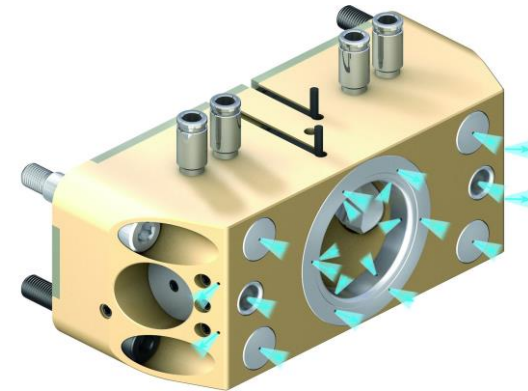

# VERO-S NSR

## Torque pin for pallets

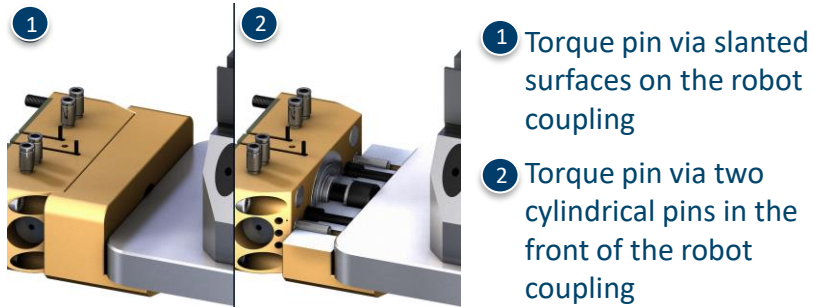

## Slim design

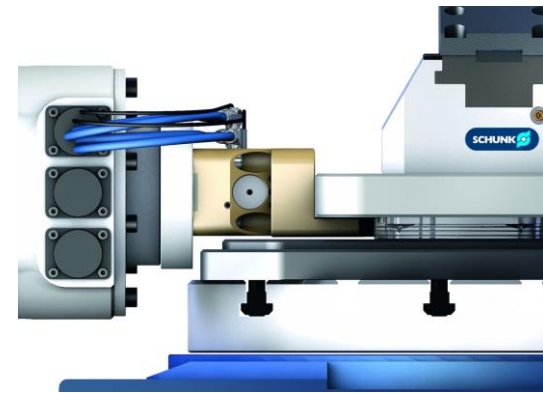

## Easy positioning – more user friendly

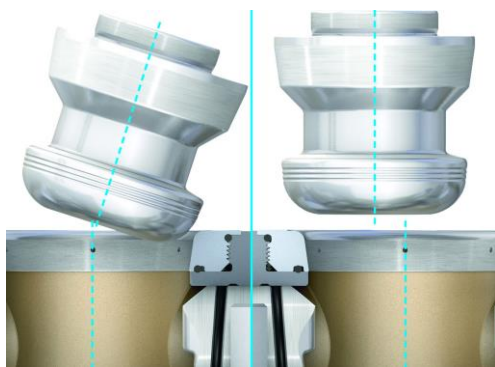

# Variants VERO-S NSR

Technical Data	NSR mini 100	NSR 160	NSR maxi 220
Length [mm]	100	159	220
Width [mm]	40	60	176
Pull-down force [kN]	1	4	12
Pull-down force with turbo [kN]	4	15	50
Unlocking pressure [bar]	6	6	6
Repeat accuracy [mm]	< 0.02	< 0.02	< 0.02
Moment Mx max. [Nm]	75	600	4000
Moment Mz max. [Nm]	200	1600	4000
Weight [kg]	0,4	1,6	21

Superior Clamping and Gripping



© 2021 SCHUNK GmbH & Co. KG  
schunk.com