

ROTA NCK plus

Advantages – Your benefits

- Interface 100% compatible with power chucks of the Kitagawa B200 series
- Precision wedge hook power chuck for highest quality requirements
- High efficiency of the wedge bar system
- Optimized lubrication system
- Base jaws with fine serration 1.5 mm x 60° and 1/16" x 90° as standard
- Blank draw nut which can be disassembled and removed is integrated in the chuck
- Modular center sleeve system
- All functional parts are ground and hardened

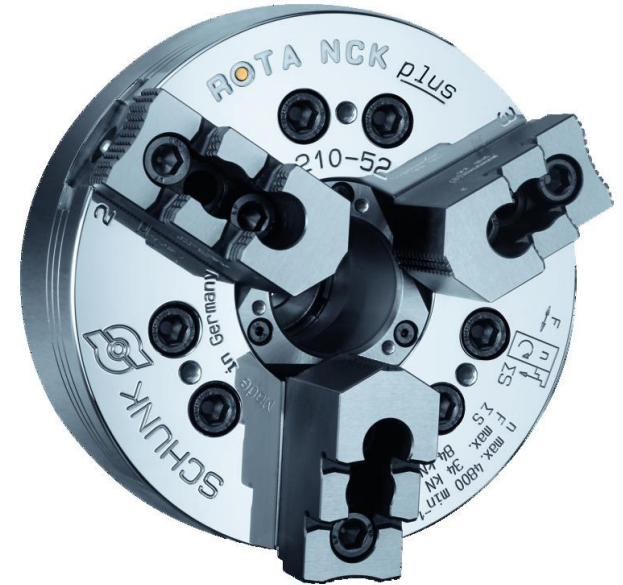

ROTA NCK plus

Example of application

Clamping device:

ROTA NCK-S plus 315 for stationary application.

Features/Application:

Lathe chuck with integrated hydraulic cylinder for automated manufacturing in milling centers.



ROTA NCK plus

Functional diagram

- 1 Wedge hook drive
- 2 Hardened and extremely rigid base body
- 3 Large through-hole
- 4 Optimized lubrication system
- 5 Mounting threads
- 6 Base jaw serration
- 7 Jaw stroke display
- 8 Blank draw nut
- 9 Various direct mountings
- 10 Modular center sleeve system

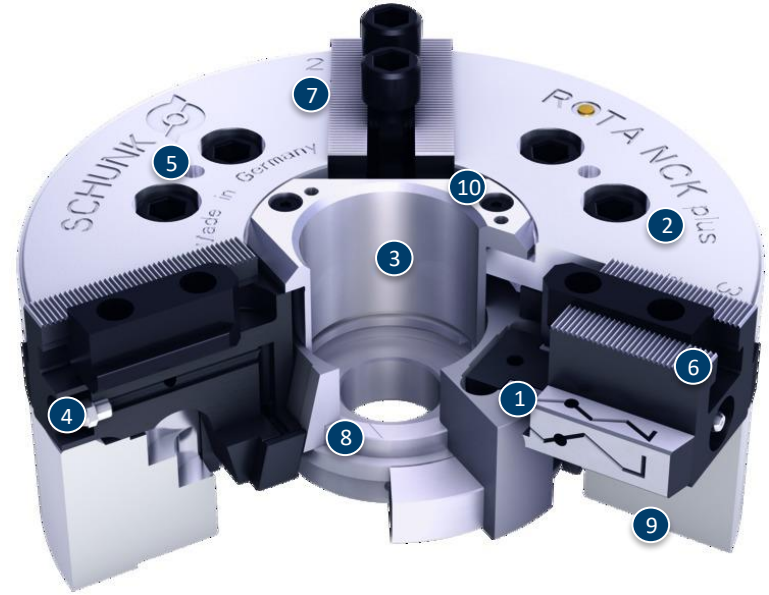

ROTA NCK plus

Modular Center Sleeve System

- 1 Adjustable stop in the center sleeve
- 2 Part ejector in the center sleeve
- 3 Closed center sleeve

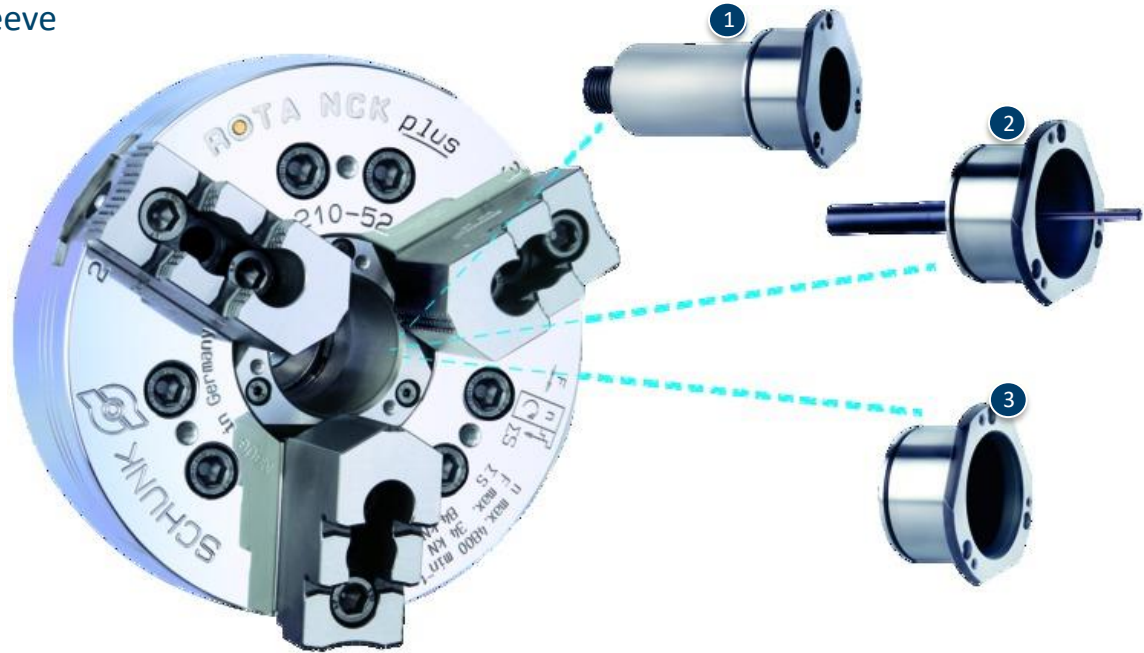

ROTA NCK plus

Highlights

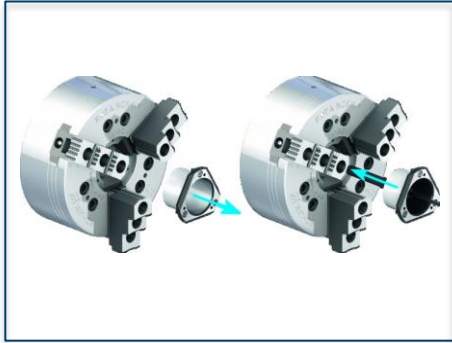

Changing the center sleeve

The modular center sleeves can be changed quickly and easily while the chuck remains mounted. When the three screws are undone, all the protection sleeves can be pulled off from the front and replaced.

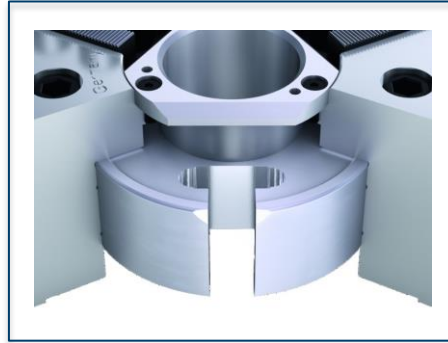

Long and precise piston guidance

For high clamping repeatability and long service life. All functional components used for force transmission are hardened and ground.

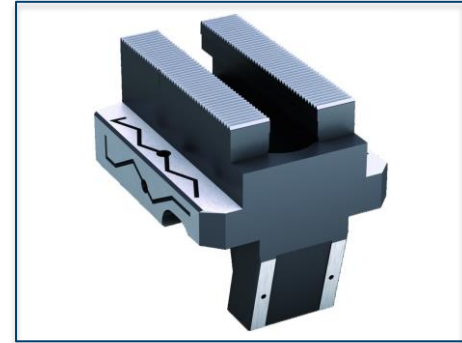

Absolute flexibility of the base jaw

Select between two standard jaw interfaces 1/16" x 90° or 1.5 mm x 60° and profit from the fact that you can continue using existing top jaws on the new SCHUNK chuck.

ROTA NCK plus

Highlights

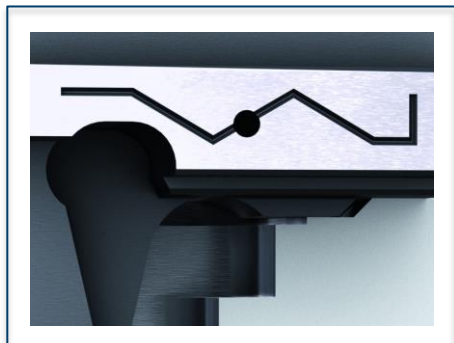

Base jaw safety feature

The small nose at the base jaw remains on the chuck body. This prevents the ejection of the jaws in case of a crash.

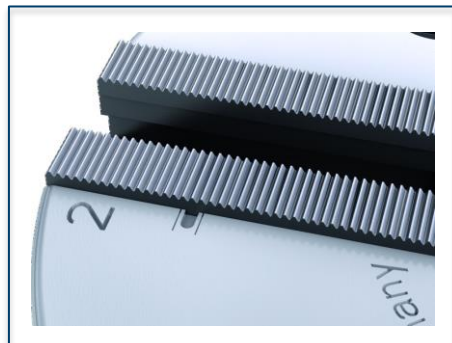

Jaw stroke display

The jaw stroke display is an additional safety feature, which ensures safe workpiece clamping and simplifies the use of the chuck in daily operation.

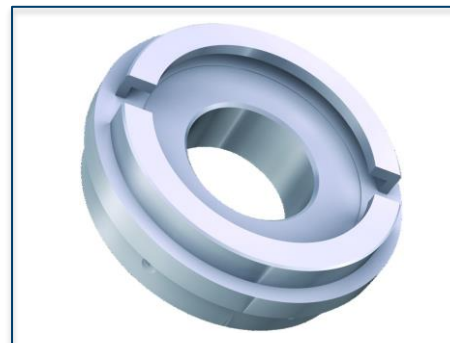

Absolute flexibility – blank draw nut

The supplied center sleeve blank can be easily disassembled and quickly adjusted to the existing draw tube.

ROTA NCK plus

Variants

Technical data	Max. RPM [min ⁻¹]	Max. clamping force [kN]	Max. actuating force [kN]	Stroke/jaw [mm]	Through-hole [mm]	Piston stroke [mm]
ROTA NCK plus 165-45	6000	57	22	2.75	45	12
ROTA NCK plus 210-52	4800	84	34	3.7	52	16
ROTA NCK plus 250-75	4200	111	44	4.4	75	19
ROTA NCK plus 315-91	3300	144	56	5.3	91	23

Superior Clamping and Gripping



© 2021 SCHUNK GmbH & Co. KG
schunk.com