



KONTEC KSG

Modular designed machine vise

Superior Clamping and Gripping



Product Overview



Gripping Systems

Clamping Technology



Chuck Jaws



Lathe Chucks



Stationary Workholding



Toolholders



Hydraulic Expansion Technology



VERO-S



TANDEM



ROTA



KONTEC



Tombstones



MAGNOS

Challenges

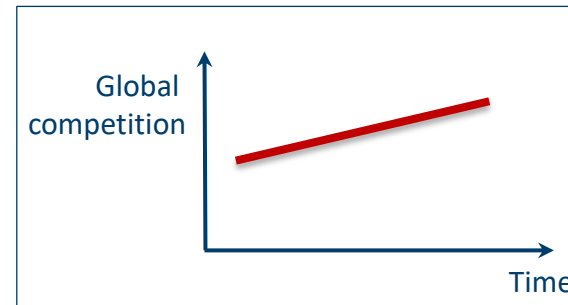
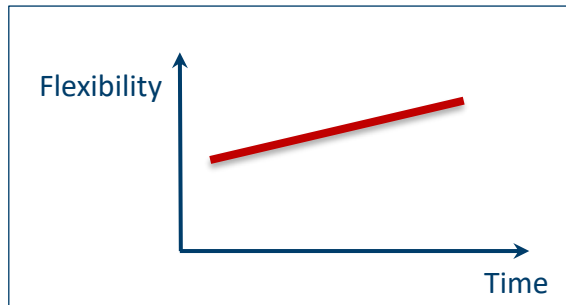
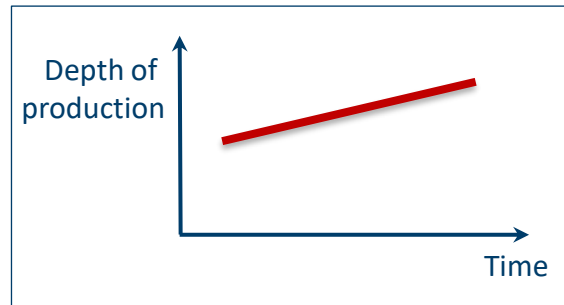

**Increasing importance
of workpiece clamping**

SCHUNK Services

Engineering

- Dimensioning of special plates designed to the manufacturing specifications
- Development of special solutions together with the customer
- FEM analysis for critical components

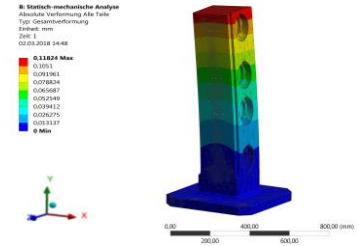

Testing

- Endurance tests with all new developments
- Abrasion checking
- Measurement of accuracy





Service

- Initial operation of customer's solution
- Inspection and maintenance
- Repairs









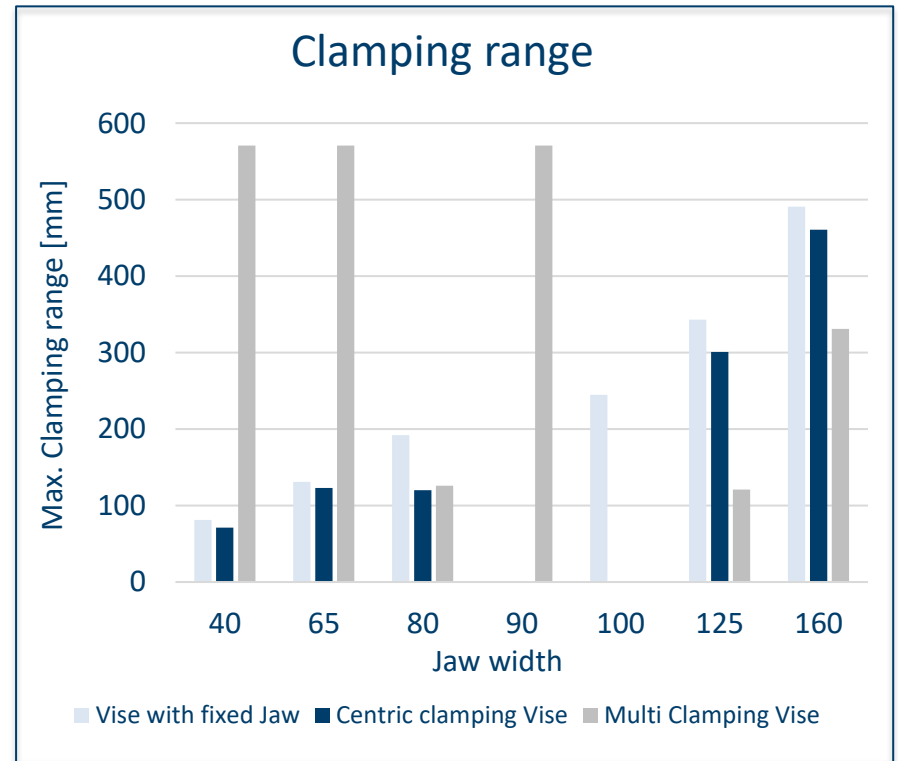
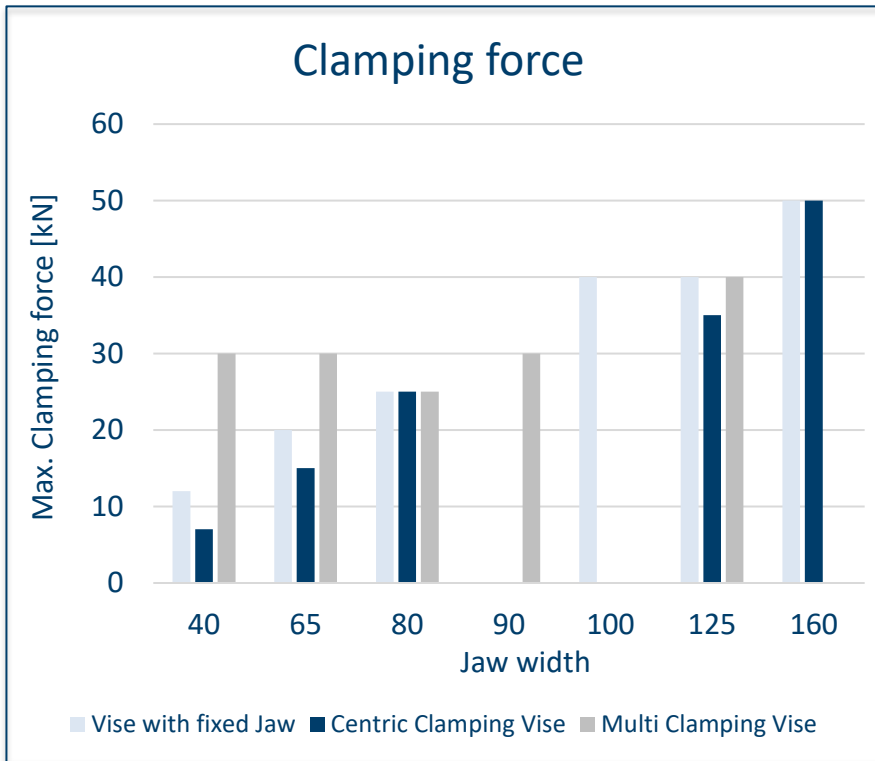

KONTEC Portfolio

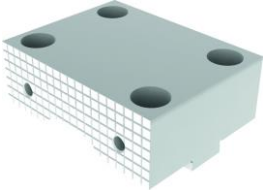
Single-acting Vise	Centric Clamping Vise	Multi Clamping Vise
		
<ul style="list-style-type: none"> • Clamping towards a fixed jaw • Fixed jaw as reference • High repeat accuracy • Especially suitable for workpieces with dimensioning from the side 	<ul style="list-style-type: none"> • Symmetric clamping • Workpiece zero point is always in the center • Optimum accessibility for 5-axis milling • Especially suitable for workpieces with dimensioning from the center 	<ul style="list-style-type: none"> • Clamping of multiple workpieces • Multifunctional usage • Reduction of setup times • Optimum usage of the machine table

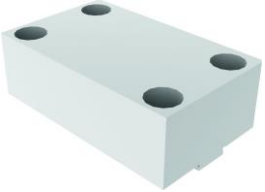
KONTEC Portfolio

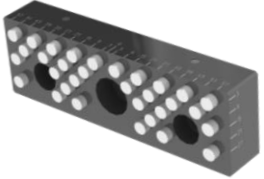
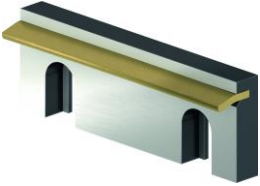

Fast adaption to new clamping tasks

System Jaws			
Standard reversible jaw	Reversible jaw, grip -grip	Enlarged span width -VS	Aluminium jaw -AL
			
Adapter- and swivel plates -R	5-axis standard jaw -5A / -5A-VS	6-fold jaw -6B	Reversible jaw grip, smooth central jaw -ST
			
Chuck Jaws			
Chuck jaw with locator pin	Spring plate, pull-down jaw	Prismatic jaw	Stepped jaw, grip
			

KONTEC Overview

Single-acting Vise



Centric Clamping Vise

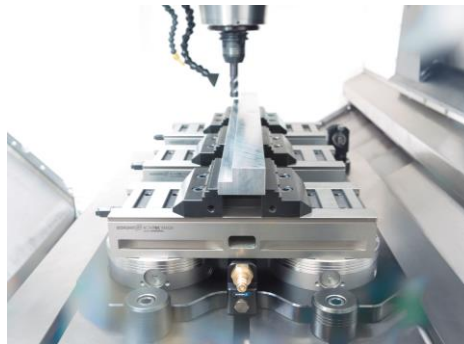

Multi Clamping Vise



KONTEC Single-acting Vise

With force amplification

KSG
Machine vise



KSX
5-axis clamping vise



Without force amplification

KSC-F
Basic clamping vise



KSO
Clamping vise for small components



KONTEC KSG

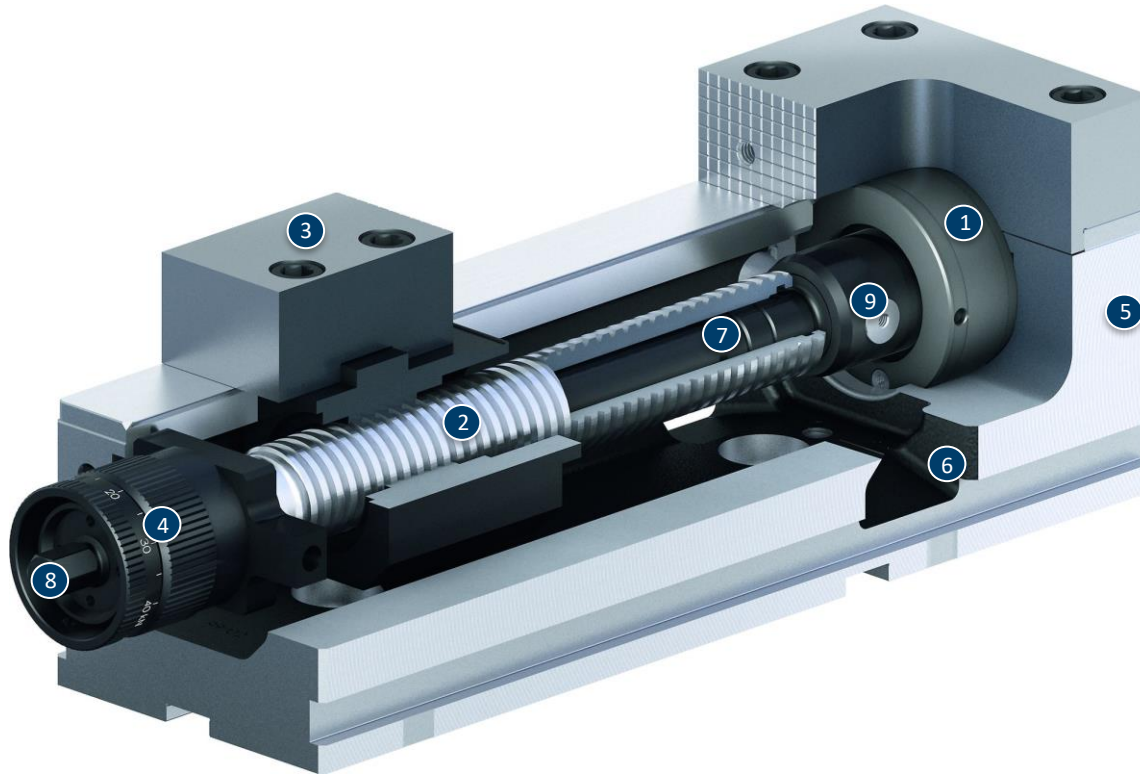

- ① Encapsulated force transmission
- ② Trouble-free clamping
- ③ Versatile range of chuck jaws
- ④ Controlled clamping force
- ⑤ Precise base body
- ⑥ Cooling lubricant drain
- ⑦ Clamping force via drawbar
- ⑧ Lever quick clamping
- ⑨ Easy removal of spindle assembly group

KONTEC KSG

Lever quick clamping



Continuously adjustable clamping force



Completely encapsulated force transmission box

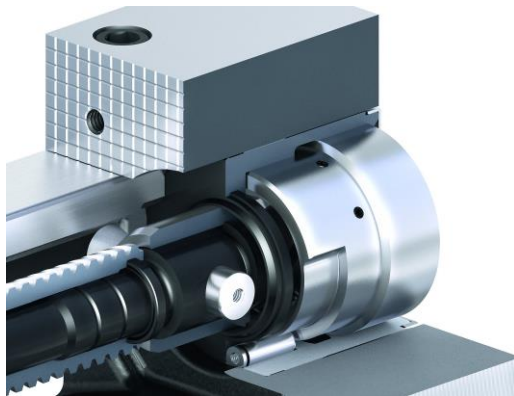

Can be cleaned and disassembled in just a few seconds

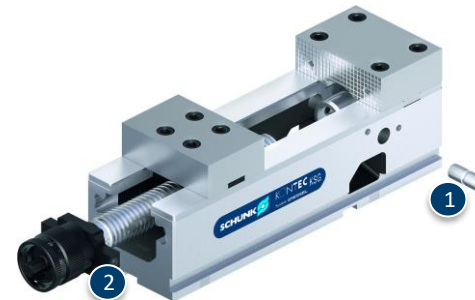

- 1 Coupling pin
- 2 Spindle assembly group

KONTEC KSG

Clamping by tension

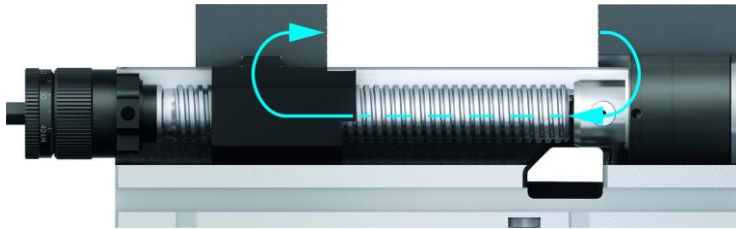

Drainage slots

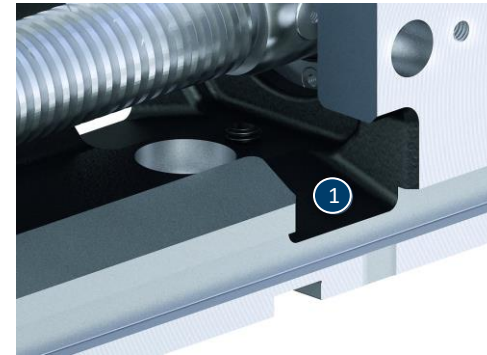

1 Drainage slot

Threads for workpiece stops in the base body

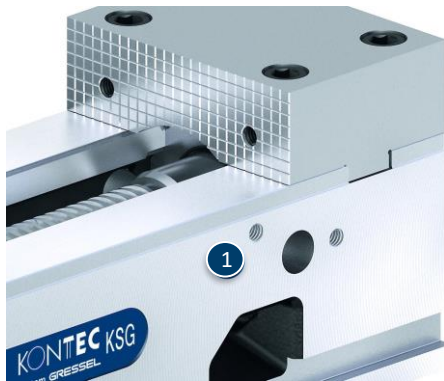

1 Thread for stops

Mounting options

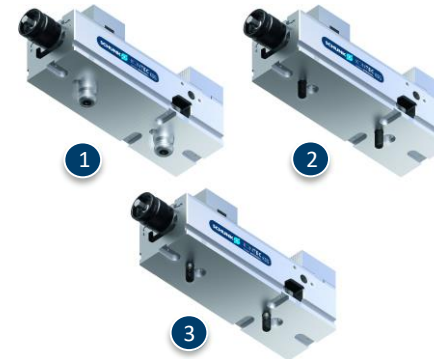

1 Fastening via quick-change pallet system

2 Fastening using two screws

3 Fastening for positional orientation using fitting screws

Variants of KONTEC KSG

Technical data	KSG 100*	KSG 125*	KSG 160*
Jaw width [mm]	100	125	160
Clamping force [kN]	4 - 30	4 - 40	4 - 40

* Additionally available in -VS, -R, -5A-VS

Superior Clamping and Gripping



© 2021 SCHUNK GmbH & Co. KG
schunk.com