



KONTEC KSS

Machine Vises

Superior Clamping and Gripping



KONTEC KSS

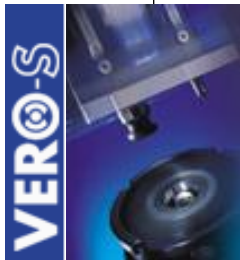
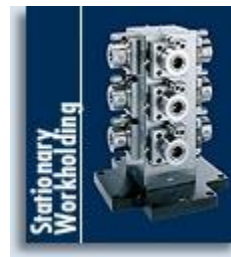

KONTEC KSS



KONTEC KSS



KSS Machine vise

Manual high-pressure gripper with continuous force adjustment. 10% to 100% clamping force with just one turn of the crank – and the final crank position stays the same. Fast adjustment of clamping ranges via disconnection bolt.

Features

- Continuously adjustable with Sensoforce
Finest adjustment of clamping force. Extra easy, powerful clamping.
- Fast, secure and convenient
Just one turn of the crank. No clamping power loss thanks to mechanical locking. Simplest handling.
- Ideal for tool and machine construction
KONTEC KSS Sensoforce clamper just grips and holds.

KONTEC KSS



Technical highlights

Mechanical clamping

- clamping < 1 second
- robust design
- high repeat accuracy due to mechanical locking
- secure locking, vibration-resistant



Mechanical force transmission

- just one turn of the crank for full clamping force
- defined crank final-position setting
- mechanical force transmission – no loss of clamping power



KONTEC KSS

Technical highlights

Continuous clamping force adjustment

- manually adjustable up to 60 kN
- continuous adjustment without tools
- fine adjusted and powerful
- reliable and quick



KONTEC KSS



1. Modular system
2. 100% encapsulated
3. Mechanical force transmission
4. Continuous clamping force adjustment
5. Just one turn of the crank
6. Low base plate
7. Interior slide guidance

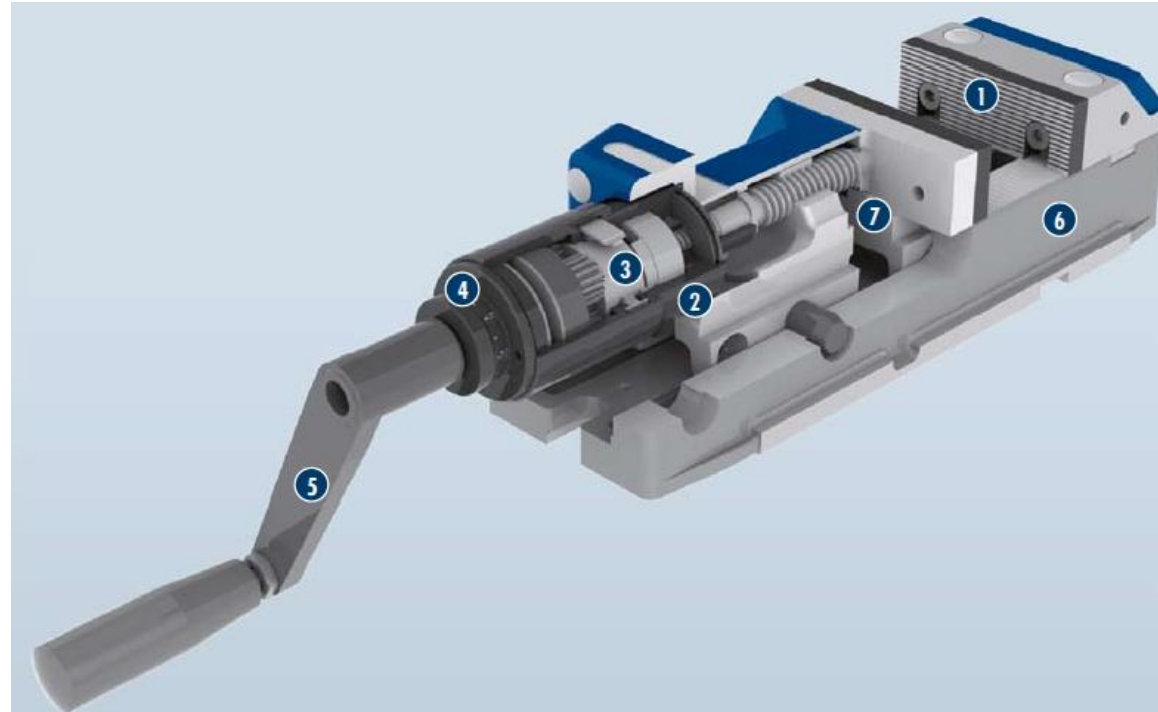

Function

Clamping with Sensoforce

Mechanical clamping with continuous fine adjustment

Just one turn of the crank

10% to 100% of clamping force with just one turn of the crank while the final crank position always remains the same

Encapsulated force transmission box

Force mechanism and setting mechanism are fully protected against dirt, chip and coolant. Wear-resistant, no servicing required.

Continuous clamping force initial setting

Manually adjustable up to 60 kN. Mechanical force-locking maintains required clamping force securely with maximum repeat accuracy – even in case of vibrations.

KONTEC KSS

Modular system



KSS Standard

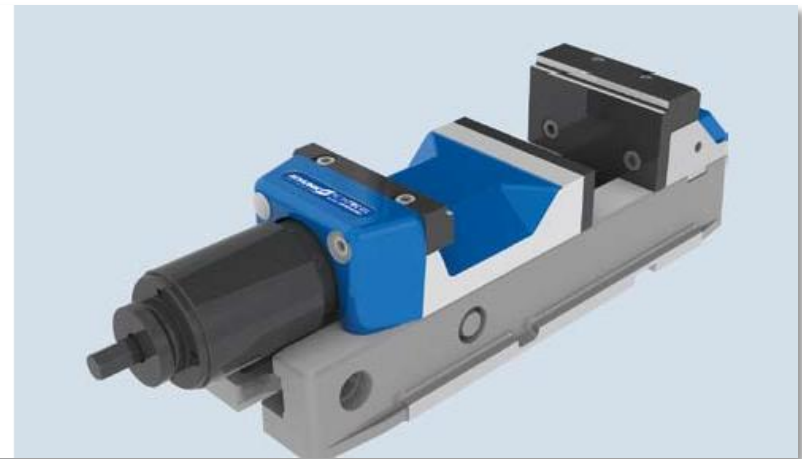

KSS VS

KONTEC KSS



KONTEC KSS 100/125/160



KSS machine vise high-pressure clamping system standard version

Scope of delivery

Jaws (profiled), crank handle, 4 clamping claws

KONTEC KSS VS 100/125/160

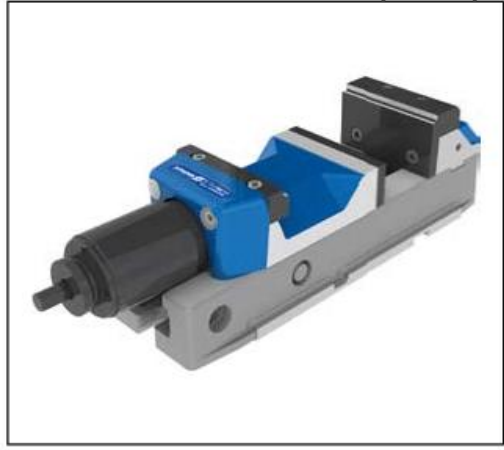

KSS machine vise high-pressure clamping system with enlarged clamping range

Scope of delivery

Jaws (profiled), crank handle, 4 clamping claws, VS jaws for enlarged clamping range

Superior Clamping and Gripping

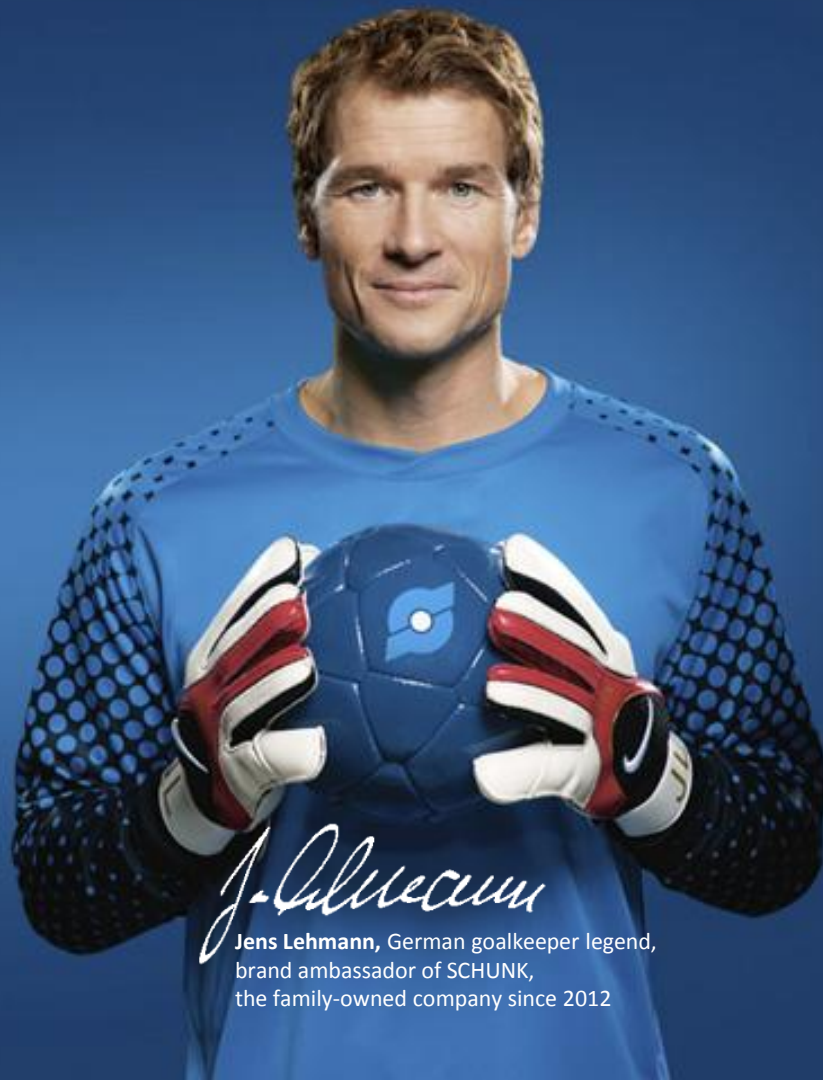

J. Lehmann

Jens Lehmann, German goalkeeper legend,
brand ambassador of SCHUNK,
the family-owned company since 2012



www.schunk.com