

VERO-S NSE mini

The extremely flat, pneumatic quick-change pallet system

Superior Clamping and Gripping



Product Overview



Gripping Systems

Clamping Technology



Chuck Jaws



Lathe Chucks



Stationary Workholding



Toolholders



Hydraulic Expansion Technology



VERO-S



KONTEC



TANDEM



ROTA



MAGNOS



PLANOS

Challenges

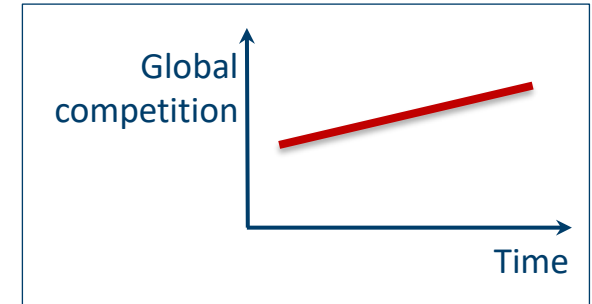
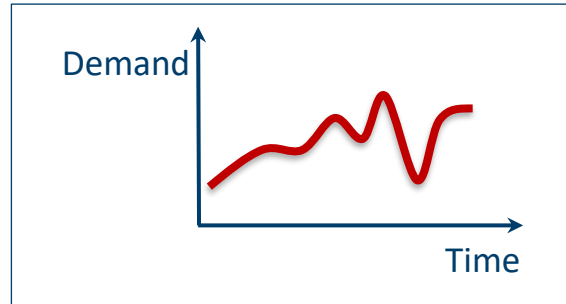
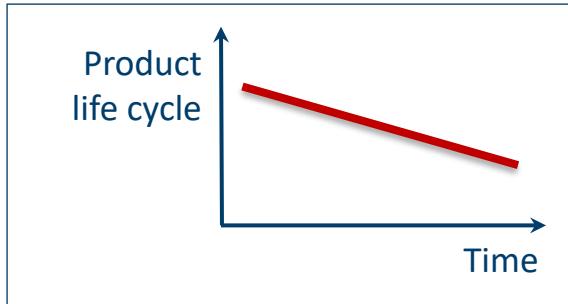
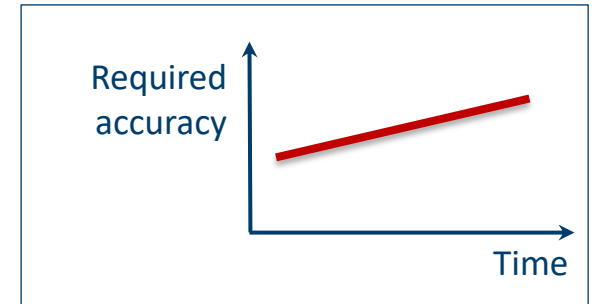
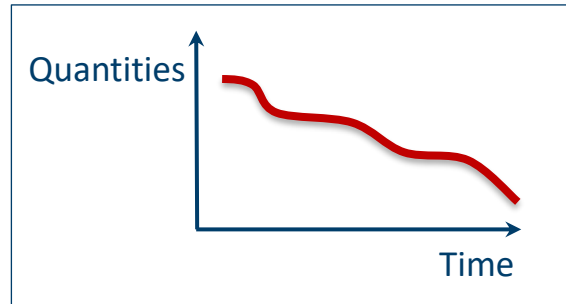
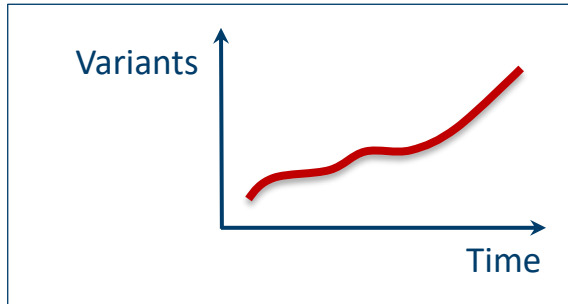

Increasing relevance of the set-up process

Potential for savings

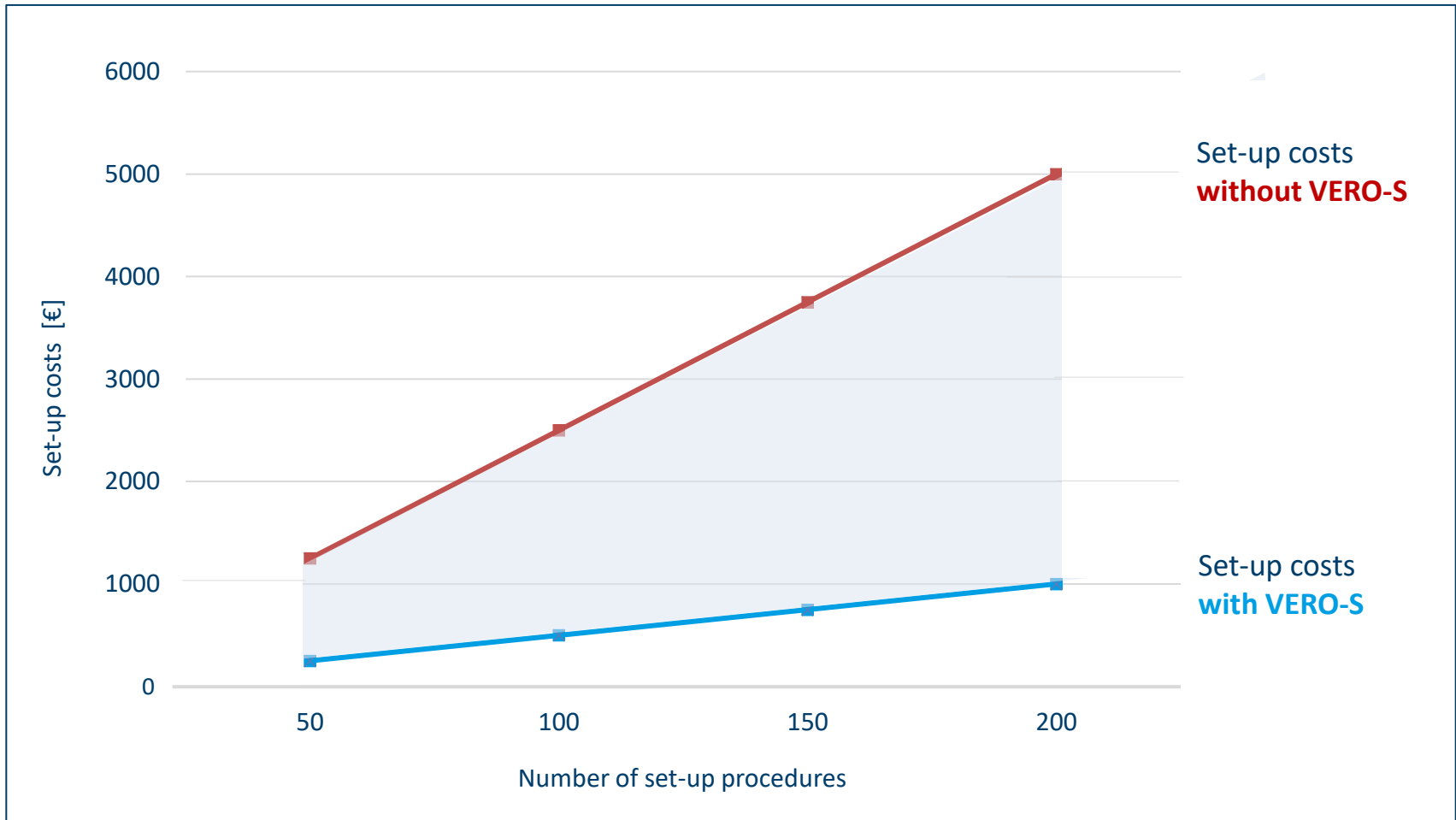

Amortisation



Even for older machines, the investment in SCHUNK VERO-S quick change pallet system amortizes within a minimum of time.

Thanks to the consistent interface of the clamping pin, the existing clamping devices can easily be integrated in the new system.

Calculation for set-up costs	Case 1	Case 2
Investment in SCHUNK VERO-S [€]	5.000	10.000
Time per set-up procedure without VERO-S [min]	25	
Time per set-up procedure with VERO-S [min]	5	
Machine costs [€/h]	60	
Number of set-up procedures per day	5	
Working days per month	20	
Working days per year	240	
Payback Time		
Set-up procedures	250	500
Working days	50	100
Months	2,5	5
Years	0,21	0,42

Consistency of pull-down and holding forces

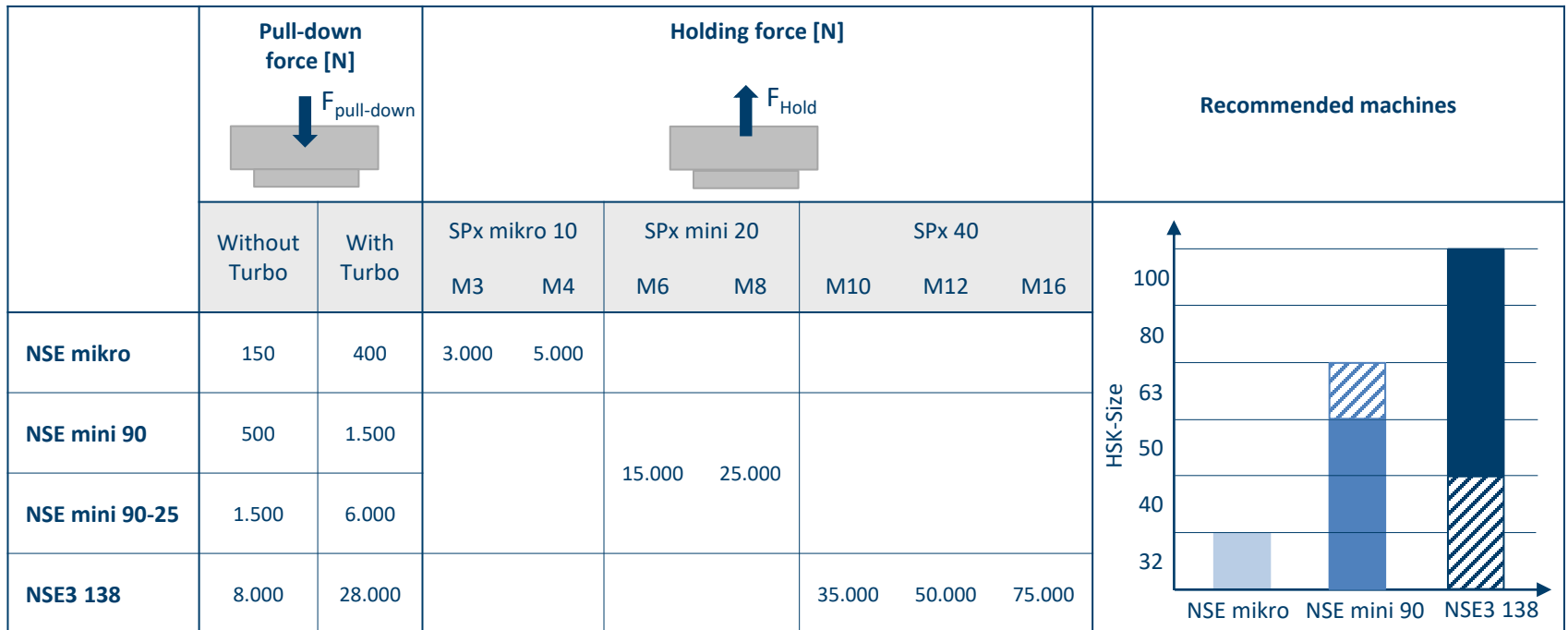

SCHUNK Services

Engineering

- Dimensioning of special plates designed to the manufacturing specifications
- Development of special solutions together with the customer
- FEM analysis for critical components

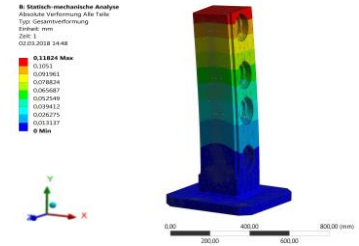

Testing

- Endurance tests with all new developments
- Abrasion checking
- Measurement of accuracy



Service

- Initial operation of customer's solution
- Inspection and maintenance
- Repairs



VERO-S Overview

General milling applications

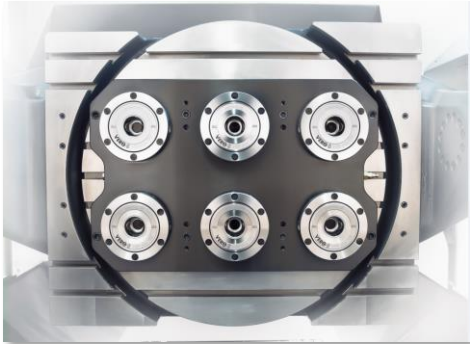

Direct workpiece clamping



Milling and turning applications

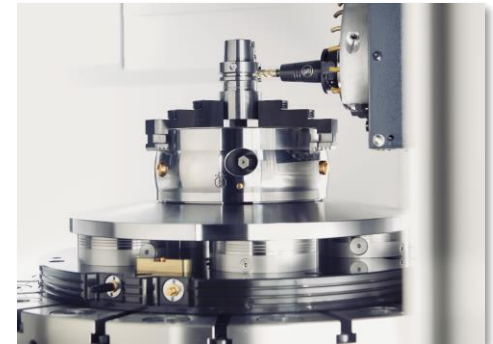

Easy milling applications

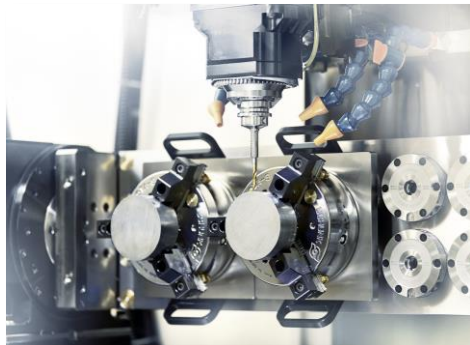

Automated machine loading

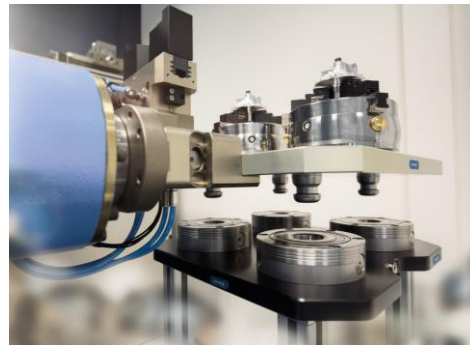

Further applications

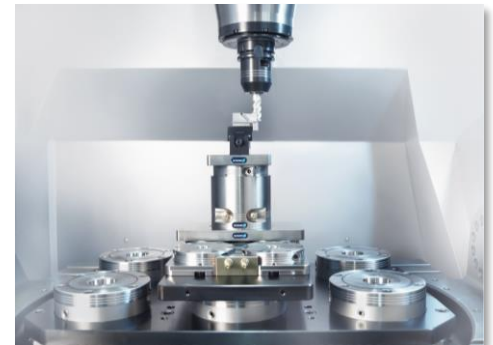

VERO-S NSE mini

Example of application



VERO-S:

Special 12-way clamping station with NSE mini 90 modules.

Features/Application:

Extrem flat buildup of the clamping station allows a higher utilization of the machining area.

VERO-S NSE mini



STAINLESS
STEEL

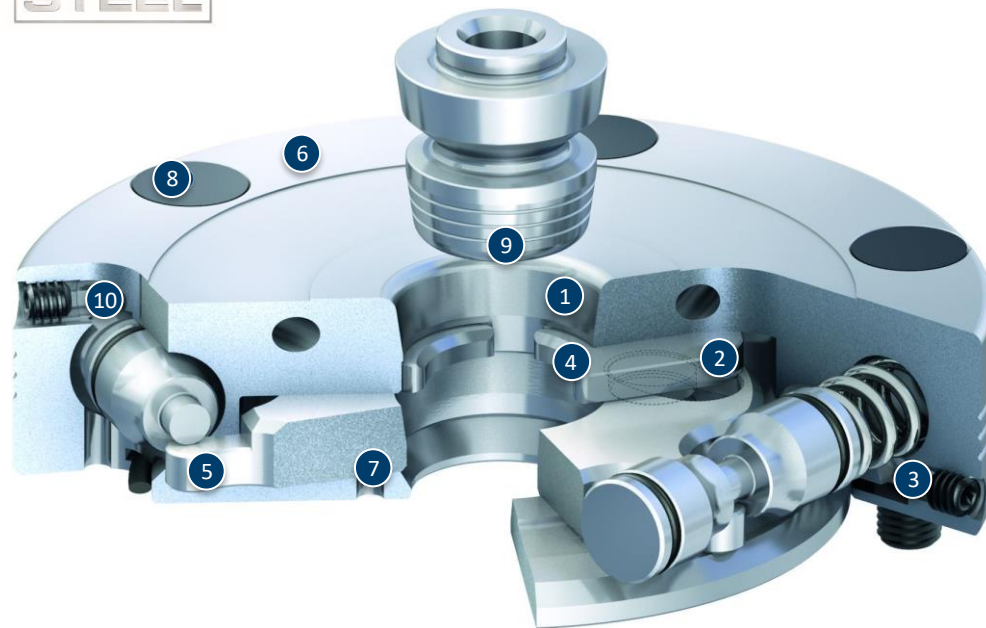

- ① High-precision short taper centering
- ② Patented dual stroke system
- ③ Turbo function
- ④ Large surfaces
- ⑤ Patented drive concept
- ⑥ Large flat surface
- ⑦ Monitoring of the clamping slide position
- ⑧ Cover caps for mounting screws
- ⑨ Entry radii on the clamping pin
- ⑩ Pneumatic system

VERO-S NSE mini

Patented drive concept in confined spaces

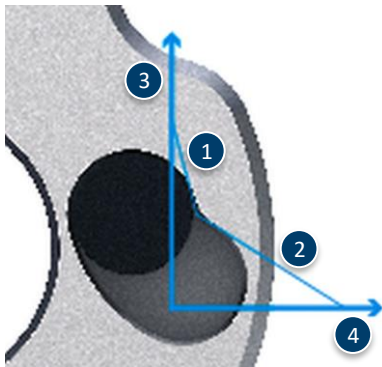

- 1 Clamping stroke
- 2 Fast stroke
- 3 Force
- 4 Travel

Patented drive concept: Triple force transmission

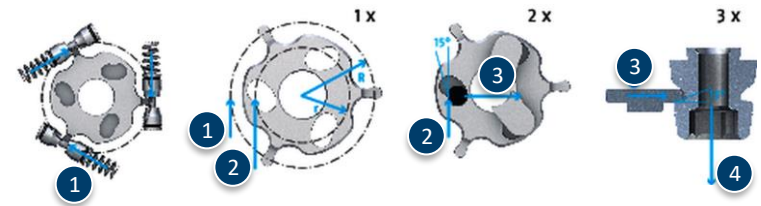

- 1 Actuation force
- 2 Force on the drive ring
- 3 Force on the clamping slide
- 4 Pull-down force

Integrated Turbo function

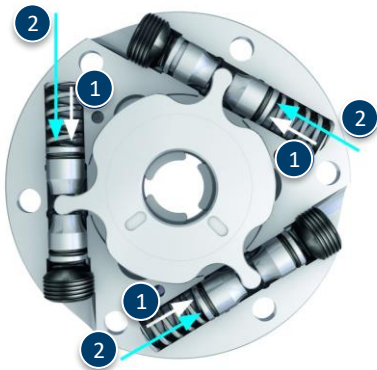

- 1 Spring force
- 2 Additional force, resulting from the turbo function

Comparison: Pull-down force spring clamping and turbo function

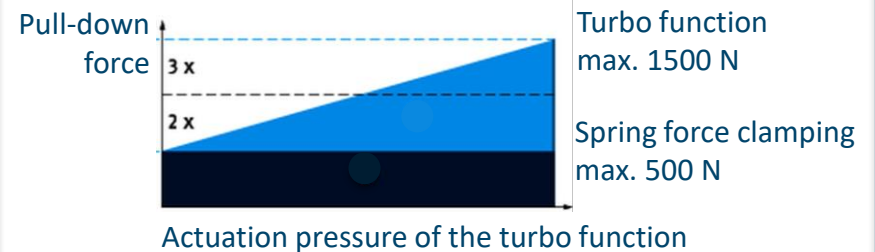

VERO-S NSE mini

Centering via short taper



Locking via clamping slide



Monitoring of the clamping slide position
via dynamic pressure

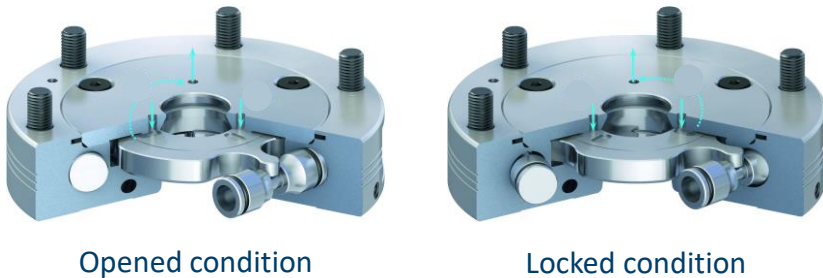

Air purge connection

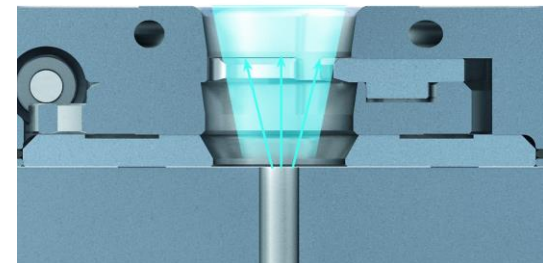

VERO-S NSE mini

Easy positioning – more user friendly

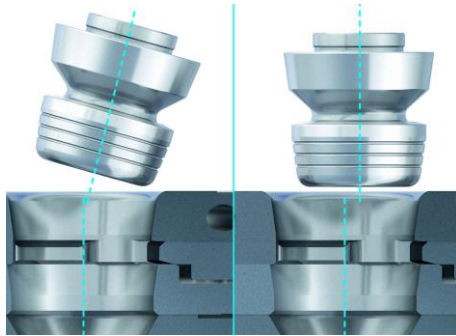

Configuration of clamping pins type A, B and C

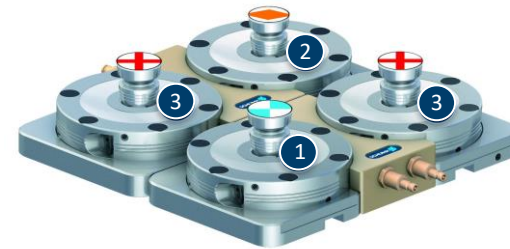

- 1 Typ A fixed
- 2 Typ B positioned
- 3 Typ C with centering play

Saves space through compact design

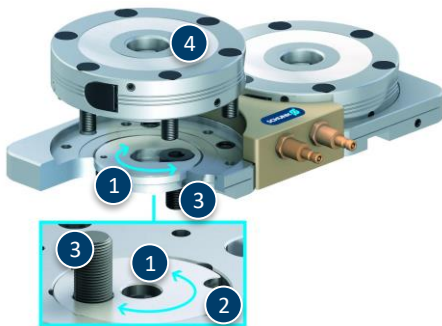

- 1 Conical spring washer for fastening
- 2 Clamp screw for presetting to the T-slot of the machine table
- 3 Fastening screw for attachment on the machine table
- 4 NSE mini 90 module

Variability due to the modular system

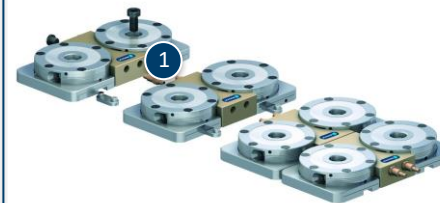

- 1 Adapter for air coupling

Variants VERO-S NSE mini

Technical Data	NSE mini	NSE-M mini 90	NSE mini 90-V1	NSE-M mini 90-V1	NSE mini 90-25	NSE mini 90-25-V10
Diameter [mm]	90	90	90	90	90	90
Pull-down force [N]	500	1000	500	1000	1500	1500
Pull-down force with turbo [N]	1500		1500		6000	6000
Unlocking pressure [bar]	6		6		6	6
Unlocking torque [Nm]		10		10		
Repeat accuracy [mm]	< 0.005	< 0.005	< 0.005	< 0.005	< 0.005	< 0.005
Weight [kg]	1	1	1	1	1.3	1.3

Variants VERO-S NSL mini

Technical Data	NSL mini 100-1 V1	NSL mini 100-2	NSL mini 100-3	NSL mini 100-4
Length [mm]	100	200	Durchmesser: 230	200
Width [mm]	100	100		200
Pull-down force [N]	500	1000	1500	2000
Pull-down force with turbo [N]	1500	3000	4500	6000
Unlocking pressure [bar]	6	6	6	6
Weight [kg]	1.7	3.5	6	7

Superior Clamping and Gripping



© 2021 SCHUNK GmbH & Co. KG
schunk.com