



Assembly and Operating Manual

GAP

2-finger angular/parallel gripper

Translation of the Original Manual

Hand in hand for tomorrow

Imprint

Copyright:

This manual is protected by copyright. The author is SCHUNK SE & Co. KG.
All rights reserved.

Technical changes:

We reserve the right to make alterations for the purpose of technical improvement.

Document number: 389418

Version: 10.00 | 31/03/2025 | en

Dear Customer,

Thank you for trusting our products and our family-owned company, the leading technology supplier of robots and production machines.

Our team is always available to answer any questions on this product and other solutions. Ask us questions and challenge us. We will find a solution!

Best regards,

Your SCHUNK team

Customer Management

Tel. +49-7133-103-2503

Fax +49-7133-103-2189

cmg@de.schunk.com



Please read the operating manual in full and keep it close to the product.

Table of Contents

1 General	5
1.1 About this manual.....	5
1.1.1 Presentation of Warning Labels	5
1.1.2 Applicable documents	6
1.1.3 Sizes.....	6
1.1.4 Variants	6
1.2 Warranty	6
1.3 Scope of delivery.....	6
1.3.1 Accessories kit	7
1.4 Accessories	7
2 Basic safety notes	8
2.1 Intended use.....	8
2.2 Constructional changes.....	8
2.3 Spare parts	8
2.4 Gripper fingers	8
2.5 Environmental and operating conditions.....	9
2.6 Personnel qualification	10
2.7 Personal protective equipment	11
2.8 Notes on safe operation.....	11
2.9 Transport.....	12
2.10 Malfunctions.....	12
2.11 Disposal	12
2.12 Fundamental dangers	13
2.12.1 Protection during handling and assembly	13
2.12.2 Protection during commissioning and operation	14
2.12.3 Protection against dangerous movements	14
2.13 Notes on particular risks	15
3 Technical data	17
4 Design and description	18
4.1 Configuration	18
4.2 Description	18
5 Assembly	19
5.1 Installing and connecting	19
5.2 Connections	20
5.2.1 Mechanical connection.....	20
5.2.2 Pneumatic connection.....	22
5.3 Adjusts absorber (variants with end position dampening).....	24

5.4	Mounting the sensor.....	26
5.4.1	Overview of sensors.....	26
5.4.2	Mounting MMS 22 magnetic switch.....	27
6	Troubleshooting.....	28
6.1	Product does not move.....	28
6.2	Product does not execute a complete stroke.....	28
6.3	Product opens or closes jerkily.....	28
6.4	Gripping force is dropping.....	29
6.5	Product does not achieve the opening and closing times.....	29
7	Maintenance.....	30
7.1	Notes.....	30
7.2	Maintenance intervals.....	30
7.3	Lubricants/Lubrication points (basic lubrication).....	31
7.4	Disassembly and assembly.....	32
7.4.1	Variant with maintenance of gripping force.....	32
7.4.2	Variant without maintenance of gripping force.....	33
7.5	Assembly drawing.....	34
8	Translation of the original declaration of incorporation.....	35
9	UKCA declaration of incorporation.....	36
10	Information on the RoHS Directive, REACH Regulation and Substances of Very High Concern (SVHC).....	37

1 General

1.1 About this manual

This manual contains important information for a safe and appropriate use of the product.

This manual is an integral part of the product and must be kept accessible for the personnel at all times.

Before starting work, the personnel must have read and understood this operating manual. Prerequisite for safe working is the observance of all safety instructions in this manual.

In addition to these instructions, the documents listed under ► 1.1.2 [6] are applicable.

NOTE: The illustrations in this manual are intended to provide a basic understanding and may deviate from the actual version.

1.1.1 Presentation of Warning Labels

To make risks clear, the following signal words and symbols are used for safety notes.



⚠ DANGER

Dangers for persons!

Non-observance will inevitably cause irreversible injury or death.



⚠ WARNING

Dangers for persons!

Non-observance can lead to irreversible injury and even death.



⚠ CAUTION

Dangers for persons!

Non-observance can cause minor injuries.

NOTICE

Material damage!

Information about avoiding material damage.

1.1.2 Applicable documents

- General terms of business *
- Catalog data sheet of the purchased product *
- Assembly and operating manuals of the accessories *

The documents labeled with an asterisk (*) can be downloaded from [schunk.com/downloads](https://www.schunk.com/downloads).

1.1.3 Sizes

This operating manual applies to the following sizes:

- GAP 16
- GAP 20
- GAP 28
- GAP 32

1.1.4 Variants

This operating manual applies to the following variations:

- GAP without gripping force maintenance, *GAP...*
- GAP with gripping force maintenance, *GAP...-AS*
- GAP with end positioning dampening of the base jaw, *GAP...-S*

1.2 Warranty

If the product is used as intended, the warranty is valid for 24 months from the ex-works delivery date under the following conditions:

- Observe the specified maintenance and lubrication intervals
- Observe the ambient conditions and operating conditions

Parts touching the workpiece and wear parts are not included in the warranty.

1.3 Scope of delivery

The scope of delivery includes

- 2-finger angular/parallel gripper GAP in the version ordered
- Safety information (product-specific instructions available online)
- Accessory pack

1.3.1 Accessories kit

Content of the accessory pack:

- 6 x centering sleeves for mounting
- 2 x O-rings for hose-free direct connection
- 2 x locking screws for hose connections

**ID.-No. of the
accessory pack**

Size	ID number
16	5522430
20	5521287
28	5521317
32	5521348

1.4 Accessories

A wide range of accessories are available for this product

For information regarding which accessory articles can be used with the corresponding product variants, see catalog data sheet.

ID.-No. of the seal kit

Size	ID number
16	0314639
20	0314609
28	0314619
32	0314629

contents of the sealing kit, ▶ 7.5 [34].

2 Basic safety notes

2.1 Intended use

The product is designed exclusively for gripping and temporarily holding workpieces or objects.

- The product may only be used within the scope of its technical data, ▶ 3 [17].
- The product is intended for installation in a machine/ automated system. The applicable guidelines for the machine/ automated system must be observed and complied with.
- The product is intended for industrial and industry-oriented use. Its use outside enclosed spaces is only permitted if suitable protective measures are taken against outdoor exposure. The product is not suitable for use in salty air.
- The product can be used within the permissible load limits and technical data for holding workpieces during simple machining operations, but is not a clamping device according to EN 1550:1997+A1:2008.
- Appropriate use of the product includes compliance with all instructions in this manual.
- Any utilization that exceeds or differs from the appropriate use is regarded as misuse.

2.2 Constructional changes

Implementation of structural changes

Modifications, changes or reworking, e.g. additional threads, holes, or safety devices, can damage the product or impair its functionality or safety.

- Structural changes should only be made with the written approval of SCHUNK.

2.3 Spare parts

Use of unauthorized spare parts

Using unauthorized spare parts can endanger personnel and damage the product or cause it to malfunction.

- Use only original spare parts or spares authorized by SCHUNK.

2.4 Gripper fingers

Requirements of gripper fingers

Accumulated energy can make the product unsafe and risk the danger of serious injuries and considerable material damage.

- Execute the gripper fingers in such a way that the product reaches either the "open" or "closed" position in a de-energized state.
- Only change gripper fingers if no residual energy can be released.
- Make sure that the product and the top jaws are a sufficient size for the application.

2.5 Environmental and operating conditions

Required ambient conditions and operating conditions

Incorrect ambient and operating conditions can make the product unsafe, leading to the risk of serious injuries, considerable material damage and/or a significant reduction to the product's life span.

- Make sure that the product and the top jaws are a sufficient size for the application.
- Ensure that maintenance and lubrication intervals are observed, ▶ 7 [30].
- Make sure that the environment is free from splash water and vapors as well as from abrasion or processing dust. Exceptions are products that are designed especially for contaminated environments.
- Make sure that the product is not exposed to excessive vibrations and/or strokes.
- Ensure that no strong magnetic fields impair the function of the product.

Contact your SCHUNK partner if the product is to be used in strong magnetic fields.

2.6 Personnel qualification

Inadequate qualifications of the personnel

If the personnel working with the product is not sufficiently qualified, the result may be serious injuries and significant property damage.

- All work may only be performed by qualified personnel.
- Before working with the product, the personnel must have read and understood the complete assembly and operating manual.
- Observe the national safety regulations and rules and general safety instructions.

The following personal qualifications are necessary for the various activities related to the product:

Trained electrician

Due to their technical training, knowledge and experience, trained electricians are able to work on electrical systems, recognize and avoid possible dangers and know the relevant standards and regulations.

Qualified personnel

Due to its technical training, knowledge and experience, qualified personnel is able to perform the delegated tasks, recognize and avoid possible dangers and knows the relevant standards and regulations.

Instructed person

Instructed persons were instructed by the operator about the delegated tasks and possible dangers due to improper behaviour.

Service personnel of the manufacturer

Due to its technical training, knowledge and experience, service personnel of the manufacturer is able to perform the delegated tasks and to recognize and avoid possible dangers.

2.7 Personal protective equipment

Use of personal protective equipment

Personal protective equipment serves to protect staff against danger which may interfere with their health or safety at work.

- When working on and with the product, observe the occupational health and safety regulations and wear the required personal protective equipment.
- Observe the valid safety and accident prevention regulations.
- Wear protective gloves to guard against sharp edges and corners or rough surfaces.
- Wear heat-resistant protective gloves when handling hot surfaces.
- Wear protective gloves and safety goggles when handling hazardous substances.
- Wear close-fitting protective clothing and also wear long hair in a hairnet when dealing with moving components.

2.8 Notes on safe operation

Incorrect handling of the personnel

Incorrect handling and assembly may impair the product's safety and cause serious injuries and considerable material damage.

- Avoid any manner of working that may interfere with the function and operational safety of the product.
- Use the product as intended.
- Observe the safety notes and assembly instructions.
- Do not expose the product to any corrosive media. This does not apply to products that are designed for special environments.
- Eliminate any malfunction immediately.
- Observe the care and maintenance instructions.
- Observe the current safety, accident prevention and environmental protection regulations regarding the product's application field.

2.9 Transport

Handling during transport

Incorrect handling during transport may impair the product's safety and cause serious injuries and considerable material damage.

- When handling heavy weights, use lifting equipment to lift the product and transport it by appropriate means.
- Secure the product against falling during transportation and handling.
- Stand clear of suspended loads.

2.10 Malfunctions

Behavior in case of malfunctions

- Immediately remove the product from operation and report the malfunction to the responsible departments/persons.
- Order appropriately trained personnel to rectify the malfunction.
- Do not recommission the product until the malfunction has been rectified.
- Test the product after a malfunction to establish whether it still functions properly and no increased risks have arisen.

2.11 Disposal

Handling of disposal

The incorrect handling of disposal may impair the product's safety and cause serious injuries as well as considerable material and environmental harm.

- Follow local regulations on dispatching product components for recycling or proper disposal.

2.12 Fundamental dangers

General

- Observe safety distances.
- Never deactivate safety devices.
- Before commissioning the product, take appropriate protective measures to secure the danger zone.
- Disconnect power sources before installation, modification, maintenance, or calibration. Ensure that no residual energy remains in the system.
- If the energy supply is connected, do not move any parts by hand.
- Do not reach into the open mechanism or movement area of the product during operation.

2.12.1 Protection during handling and assembly

Incorrect handling and assembly

Incorrect handling and assembly may impair the product's safety and cause serious injuries and considerable material damage.

- Have all work carried out by appropriately qualified personnel.
- For all work, secure the product against accidental operation.
- Observe the relevant accident prevention rules.
- Use suitable assembly and transport equipment and take precautions to prevent jamming and crushing.

Incorrect lifting of loads

Falling loads may cause serious injuries and even death.

- Stand clear of suspended loads and do not step into their swiveling range.
- Never move loads without supervision.
- Do not leave suspended loads unattended.

2.12.2 Protection during commissioning and operation

Falling or violently ejected components

Falling and violently ejected components can cause serious injuries and even death.

- Take appropriate protective measures to secure the danger zone.
- Never step into the danger zone during operation.

2.12.3 Protection against dangerous movements

Unexpected movements

Residual energy in the system may cause serious injuries while working with the product.

- Switch off the energy supply, ensure that no residual energy remains and secure against inadvertent reactivation.
- Never rely solely on the response of the monitoring function to avert danger. Until the installed monitors become effective, it must be assumed that the drive movement is faulty, with its action being dependent on the control unit and the current operating condition of the drive. Perform maintenance work, modifications, and attachments outside the danger zone defined by the movement range.
- To avoid accidents and/or material damage, human access to the movement range of the machine must be restricted. Limit/prevent accidental access for people in this area due through technical safety measures. The protective cover and protective fence must be rigid enough to withstand the maximum possible movement energy. EMERGENCY STOP switches must be easily and quickly accessible. Before starting up the machine or automated system, check that the EMERGENCY STOP system is working. Prevent operation of the machine if this protective equipment does not function correctly.

2.13 Notes on particular risks



⚠ DANGER

Risk of fatal injury from suspended loads!

Falling loads can cause serious injuries and even death.

- Stand clear of suspended loads and do not step within their swiveling range.
- Never move loads without supervision.
- Do not leave suspended loads unattended.
- Wear suitable protective equipment.



⚠ WARNING

Risk of injury from objects falling and being ejected!

Falling and ejected objects during operation can lead to serious injury or death.

- Take appropriate protective measures to secure the danger zone.



⚠ WARNING

Risk of injury from sharp edges and corners!

Sharp edges and corners can cause cuts.

- Use suitable protective equipment.



⚠ WARNING

Risk of injury due to unexpected movements!

If the power supply is switched on or residual energy remains in the system, components can move unexpectedly and cause serious injuries.

- Before starting any work on the product: Switch off the power supply and secure against restarting.
- Make sure, that no residual energy remains in the system.



⚠ WARNING

Risk of injury from crushing and impacts!

Serious injury could occur during movement of the base jaw, due to breakage or loosening of the gripper fingers or if the workpiece is lost.

- Wear suitable protective equipment.
- Do not reach into the open mechanism or the movement area of the product.



⚠ WARNING

Risk of injury due to spring forces!

Parts are under spring tension on products which clamp using spring force or which have gripping force maintenance. While disassembling components can move unexpectedly and cause serious injuries.

- Disassemble the product cautiously.
- Make sure that no residual energy remains in the system.



⚠ WARNING

Risk of injury from objects falling during energy supply failure

Products with a mechanical gripping force maintenance can, during energy supply failure, still move independently in the direction specified by the mechanical gripping force maintenance.

- Secure the end positions of the product with SCHUNK SDV-P pressure maintenance valves.

3 Technical data

Connection data

Pressure medium	Compressed air, compressed air quality according to ISO 8573-1:2010 [7:4:4]
Nominal operating pressure [bar]	6
Minimum pressure [bar] without maintenance of gripping force	3
Minimum pressure [bar] with maintenance of gripping force	4.5
Maximum pressure [bar] without maintenance of gripping force	7
Maximum pressure [bar] with maintenance of gripping force	6.5

Ambient conditions and operating conditions

Ambient temperature [°C]	
min.	+5
max.	+60
Protection class IP	40
Noise emission [dB(A)]	≤ 70

More technical data is included in the catalog data sheet. Whichever is the latest version.

4 Design and description

4.1 Configuration

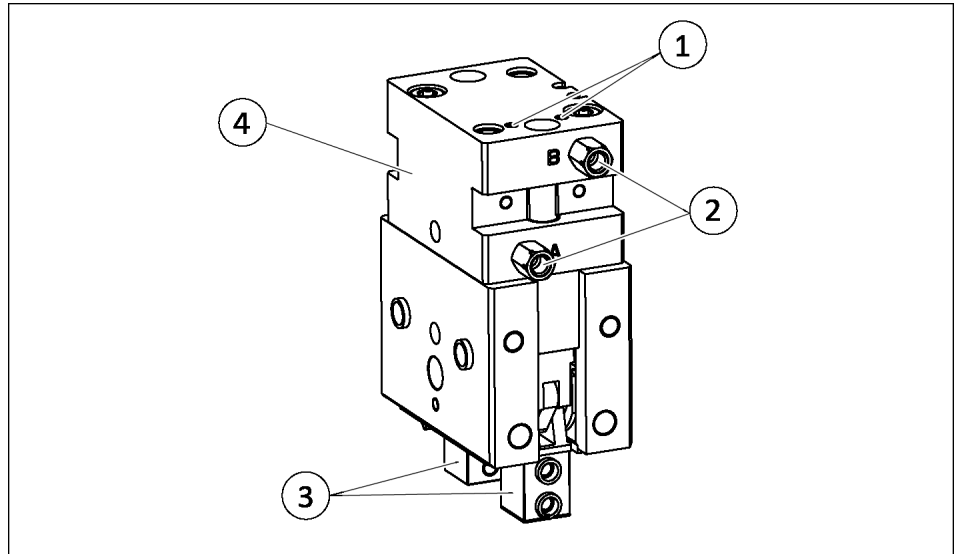

2-finger angular/parallel gripper

- | | |
|---|--|
| 1 | Hose-free direct connection |
| 2 | Main air connections (A = open, B = close) |
| 3 | Base jaw |
| 4 | Case |

4.2 Description

2-finger angle parallel gripper for parallel external gripping with prior swivelling of the gripper fingers up to 90° per jaw

5 Assembly

5.1 Installing and connecting

NOTICE

Damage to the gripper is possible!

If the maximum permissible finger weight or the permissible mass moment of inertia of the fingers is exceeded, the gripper can be damaged.

- A jaw movement always has to be without jerks and bounce.
- You must therefore implement sufficient reduction and/or damping.
- Observe the information in the catalog data sheet.

1. Check the flatness of the mounting surface, ▶ 5.2.1 [20].
2. Connect the product via the hose-free direct connection, ▶ 5.2.2 [22].
 - ⇒ Screw throttles in the main air connections *A* and *B*.
3. OR: Connect supply lines to the main air connections *A* and *B*, ▶ 5.2.2 [22].
 - ⇒ Unscrew locking screws.
 - ⇒ Screw on air connections
 - ⇒ OR: Screw on air throttle in order to be able to perform sufficient throttling and/or dampening.
4. Screw the product to the machine/system, ▶ 5.2.1 [20].
 - ⇒ Use suitable connecting elements (adapter plates) if necessary.
 - ⇒ Observe the permissible depth of engagement.
 - ⇒ Observe the tightening torque for the mounting screws.
5. Connect the sensor, see Sensor Assembly and Operating Manual.
6. Install the sensor, ▶ 5.4 [26].

5.2 Connections

5.2.1 Mechanical connection

NOTE

When mounting the product and when mounting loads, do not allow impermissible forces and moments to be exerted, see catalog data sheet.

Select a suitable tightening torque when assembling the product or loads on the product in accordance with the generally accepted guidelines for screw connections.

Secure all screw connections using a suitable chemical screw lock.

Evenness of the mounting surface

The values apply to the whole mounting surface to which the product is mounted.

Edge length	Permissible unevenness
< 100	< 0.02
> 100	< 0.05

Tab.: Requirements for evenness of the mounting surface (Dimensions in mm)

Mounting

The connection geometries are above and at the side of the product. See catalog for dimensions to position the mounting holes.

1. Use the provided fixing bores for mounting the product on the side. For the tightening torque, see following table.
2. Fasten the product using the mounting holes provided for this purpose.

Size	Tightening torque [Nm]
16	3
20	6
28	6
32	6

Tab.: Max. permissible tightening torque for lateral mounting

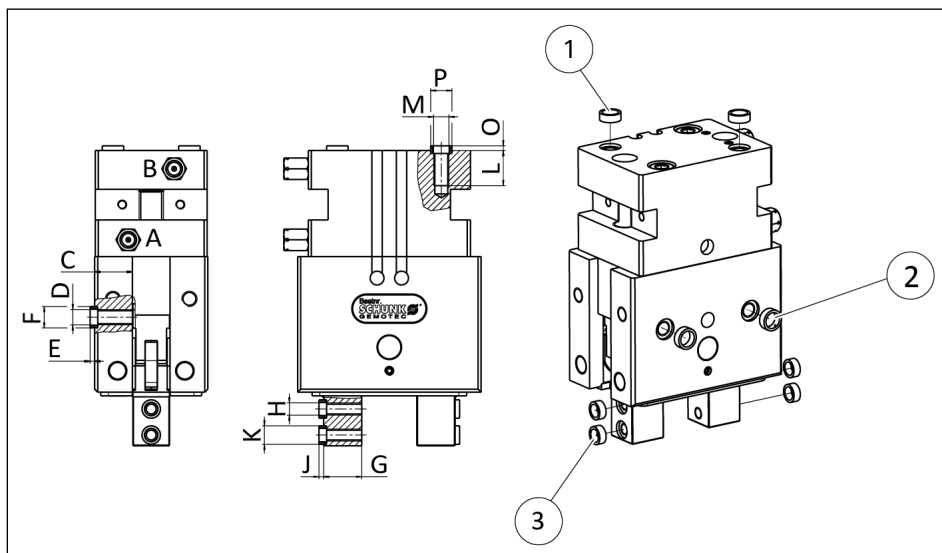

Size	Centering sleeve		
	①	②	③
16	∅6 x 2.5 (2x)	∅7 x 2.5 (2x)	∅5 x 2.5 (4x)
20	∅6 x 2.5 (2x)	∅7 x 2.5 (2x)	∅5 x 2.5 (4x)
28		∅7 x 2.5 (2x)	∅6 x 2.5 (4x)
32		∅7 x 2.5 (6x)	

Tab.: Centering sleeve (Included in the accessory kit)

Size	C [mm]	D	E [mm]	F	G [mm]	H	J [mm]	K	L [mm]	M	O [mm]	P
16	6.5	M5	1.5	∅7H7	8.0	M3	1.5	∅5H7	8.0	M4	1.5	∅6H7
20	9.5	M5	1.5	∅7H7	10.0	M3	1.5	∅5H7	9.0	M4	1.5	∅6H7
28	12.0	M5	1.5	∅7H7	12.5	M4	1.5	∅6H7	11.5	M5	1.5	∅7H7
32	11.0	M5	1.5	∅7H7	15.5	M5	1.5	∅7H7	11.5	M5	1.5	∅7H7

5.2.2 Pneumatic connection

NOTICE

Damage to the gripper is possible!

If the maximum permissible finger weight or the permissible mass moment of inertia of the fingers is exceeded, the gripper can be damaged.

- A jaw movement always has to be without jerks and bounce.
- You must therefore implement sufficient reduction and/or damping.
- Observe the information in the catalog data sheet.

NOTICE

When using the main air connections "A" and "B" GAP 16 – 32 the gripper must be throttled by external throttle screw connections for 16 – 32.

- Do not remove pre-assembled fixed throttle fittings.

NOTICE

When using the direct connections "a" and "b" throttling for GAP 16 – 32 is also necessary.

- Attach the supplied fixed throttle screw connection to the connections of the adapter plate.

NOTE

- Observe the requirements for the compressed air supply, ▶ 3 [17].
- In case of compressed air loss (cutting off the energy line), the components lose their dynamic effects and do not remain in a secure position. However, the use of a SDV-P pressure maintenance valve is recommended in this case in order to maintain the dynamic effect for some time. Product variants are also offered with mechanical gripping force via springs, which also ensure a minimum clamping force in the event of a pressure drop.

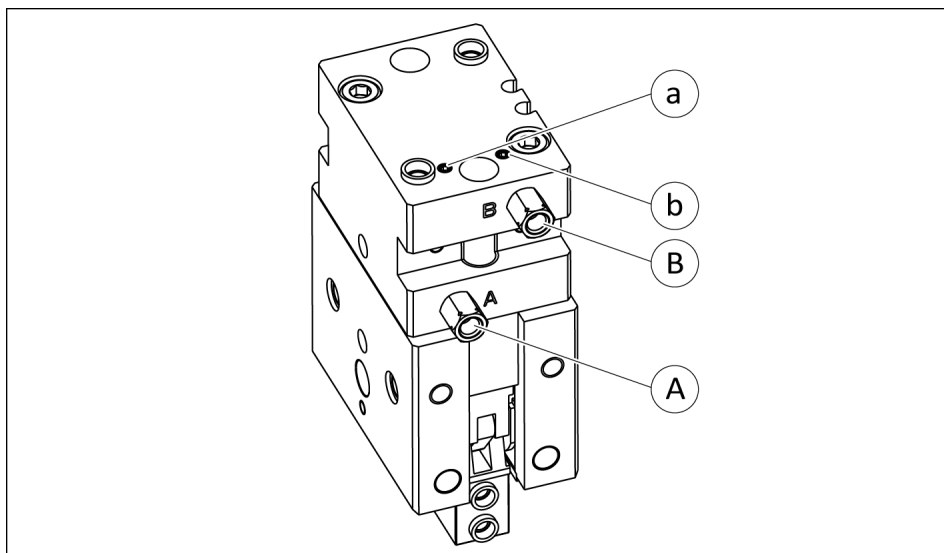

Pneumatic connection

Main connections		
Size	A Open gripper	B Close gripper
16	M3	M3
20	M5	M5
28	M5	M5
32	M5	M5

Hose-free direct connection	
a Open gripper	b Close gripper

For connection dimensions and geometry, see catalogue

- Only open the air connections required.
- Seal air connections not required using the locking screws from the enclosed pack.
- For hose-free direct connections use the two O-rings from the enclosed pack.

5.3 Adjusts absorber (variants with end position dampening)

NOTE

- Do not use absorber to limit the gripper stroke.
- Set both absorbers to the same dimension.

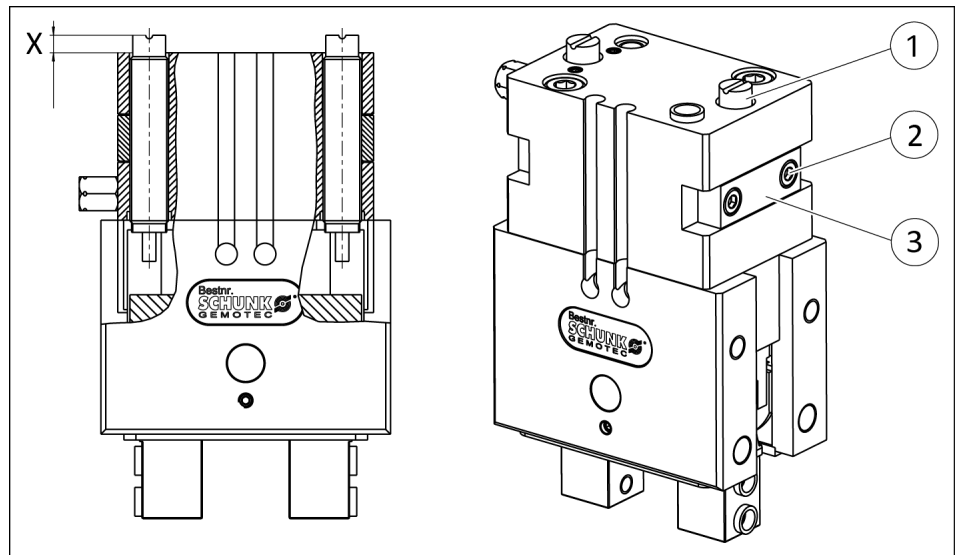

Adjust absorber

1. Unscrew cylinder screws (3).
2. Loosen clamping piece (2), if necessary.
3. Set both absorbers (1) to dimension X.
4. Screw cylinder screws (3) tight.
Note: Secure all cylinder screws using a suitable chemical screw lock.

Size	Tightening torque [Nm]
16	0.6
20	0.8
28	1.5
32	3.0

Tab.: Tightening torque for attachment screws

Size	Dimension X [mm]
16-30-S	-7.2
16-60-S	-4.6
16-90-S	-2.1
20-30-S	-10.6
20-60-S	-7.4
20-90-S	-3.9
28-30-S	-3.9
28-60-S	-0.3

Size	Dimension X [mm]
28-90-S	3.6
32-30-S	-6.4
32-60-S	-2
32-90-S	2.8

Tab.: Dimension X for absorber setting – maximum absorber stroke

5.4 Mounting the sensor

NOTE

Observe the assembly and operating manual of the sensor for mounting and connecting.

The product is prepared for the use of sensors.

- For the exact type designations of suitable sensors, please see catalog datasheet and ▶ 5.4.1 [📄 27].
- For technical data for the suitable sensors, see assembly and operating manual and catalog datasheet.
 - The assembly and operating manual and catalog datasheet are included in the scope of delivery for the sensors and are available at schunk.com.
- Information on handling sensors is available at schunk.com or from SCHUNK contact persons.

5.4.1 Overview of sensors

Designation	GAP			
	16	20	28	32
Magnetic switch MMS 22	X	X	X	X

5.4.2 Mounting MMS 22 magnetic switch

NOTICE

Material damage due to an incorrect tightening torque!

If the threaded pin is tightened with an incorrect tightening torque, the product may be damaged.

- Observe a maximum tightening torque of 10 Ncm for the set-screws.

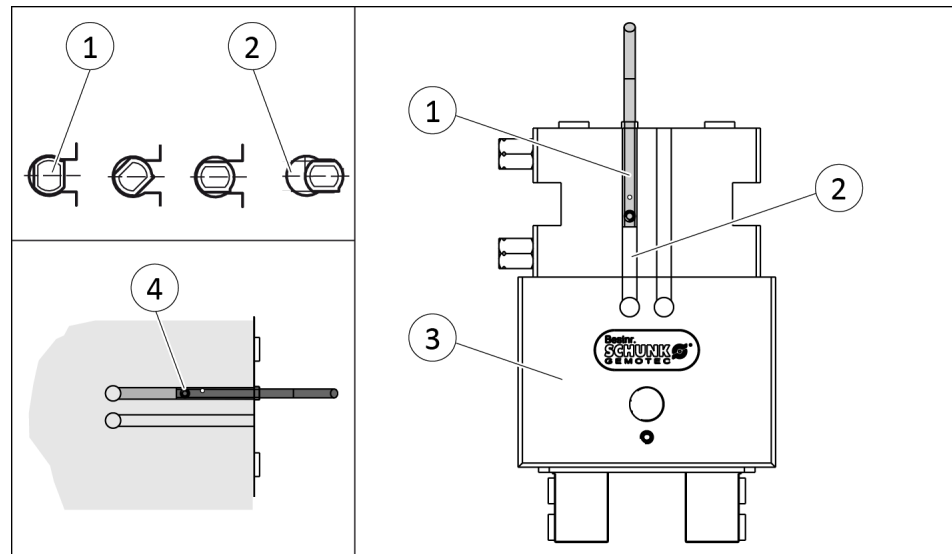

Gripper position opened or part gripped (I.D. gripping)

1. Put product in the position in which it is to be set.
2. Turn the sensor 1 (1) into the groove (2).
OR: Push the sensor 1 (1) into the groove (2) until sensor 1 (1) stops at the housing (3).
3. Pull the sensor 1 (1) back again slowly until it switches.
4. Secure the sensor 1 (1) using the set-screw (4).
⇒ Tightening torque: 10 Ncm
5. Close the product and open it again in order to test its function.
6. Repeat steps for sensor 2.

Gripper position closed or part gripped (O.D gripping)

1. Put product in the position in which it is to be set.
2. Turn the sensor 1 (1) into the groove (2).
OR: Slide sensor 1 (1) into the groove (2) in the direction of the housing middle (3), until the sensor 1 (1) switches.
3. Secure the sensor 1 (1) using the set-screw (4).
⇒ Tightening torque: 10 Ncm
4. Close the product and open it again in order to test its function.
5. Repeat steps for sensor 2.

6 Troubleshooting

6.1 Product does not move

Possible cause	Corrective action
Base jaws jam in housing, e.g. mounting surface is not sufficiently even.	Check the evenness of the mounting surface., ▶ 5.2.1 [☐ 20] Loosen the mounting screws of the product and actuate the product again.
Pressure drops below minimum.	Check air supply., ▶ 5.2.2 [☐ 22]
Compressed air lines switched.	Check compressed air lines.
Proximity switch defective or set incorrect.	Readjust or change sensor.
Component part defective.	Replace component or send it to SCHUNK for repair.

6.2 Product does not execute a complete stroke

Possible cause	Corrective action
Variant GAP...-S Damper turned in too far (piston does not reach end position).	Adjusting damping., ▶ 5.3 [☐ 24]
Dirt deposits in the mechanical elements.	Clean and lubricate product.▶ 7 [☐ 30]
Dirt deposits between the housing and base jaws.	Disassemble and clean the product. ▶ 7 [☐ 30]
Pressure drops below minimum.	Check air supply. ▶ 3 [☐ 17]
Mounting surface is not sufficiently flat.	Check the evenness of the mounting surface. ▶ 5.2.1 [☐ 20]
Component part defective.	Replace component or send it to SCHUNK for repair.

6.3 Product opens or closes jerkily

Possible cause	Corrective action
Too little grease in the mechanical guiding areas.	Clean and lubricate product. ▶ 7 [☐ 30]
Compressed air lines blocked.	Check compressed air lines of damage.
Mounting surface is not sufficiently flat.	Check the evenness of the mounting surface.
One-way flow control valve is missing or adjustet incorrectly.	Install and adjust one-way flow control valve.

6.4 Gripping force is dropping

Possible cause	Corrective action
Compressed air can escape.	Check seals, if necessary, disassemble the product and replace seals.
Too much grease in the mechanical movement space.	Clean and lubricate product.
Pressure drops below minimum.	Check air supply. ▶ 3 [17]
Component part defective.	Replace component or send it to SCHUNK for repair.

6.5 Product does not achieve the opening and closing times

Possible cause	Corrective action
Compressed air lines are not installed optimally.	If present: Open the flow control couplings on the product to the maximum that the movement of the jaws occurs without bouncing and hitting.
	Check compressed air lines.
	Inner diameters of compressed air lines are of sufficient size in relation to compressed air consumption.
	Keep compressed air lines between the product and directional control valve as short as possible.
	Flow rate of valve is sufficiently large relative to the compressed air consumption.
	NOTICE! The throttle check valve must not be removed, even if the product has not reached the opening and closing times.
Loading too large.	If you still cannot achieve the open and close times in the latest catalog, we recommend the use of quick-air-vent-valves directly at the product.
	Check permissible weight and length of the gripper fingers.

7 Maintenance

7.1 Notes

Original spare parts

Use only original spare parts of SCHUNK when replacing spare and wear parts.

NOTE

Use suitable devices and aids for assembly of the springs (154)(for variant AS) and (124).

7.2 Maintenance intervals

Interval [Mio. cycles]	Maintenance work
2	Clean the product dry without a degreasing agent, check for damage and wear, if necessary replace seals and wearing parts, ▶ 7.4 [32].
2	Treat all grease areas with lubricant, ▶ 7.3 [31].

For extreme ambient and application conditions, shortened maintenance cycles can ensure the lifespan is maintained.

NOTICE

Material damage due to hardening lubricants!

Lubricants harden more quickly at temperatures above 60°C, leading to possible product damage.

- Reduce the lubricant intervals accordingly.
-

7.3 Lubricants/Lubrication points (basic lubrication)

SCHUNK recommends the lubricants listed.

Greasing area	Lubricant
Lever mechanism and connecting members	SCHUNK grease 10
Seals and sealing surfaces *	SCHUNK grease 1

* only after disassembling the product

Details regarding SCHUNK lubricant designations are available at schunk.com/lubricants.

The product contains food-compliant lubricants as standard.

The requirements of standard EN 1672-2:2020 are not fully met.

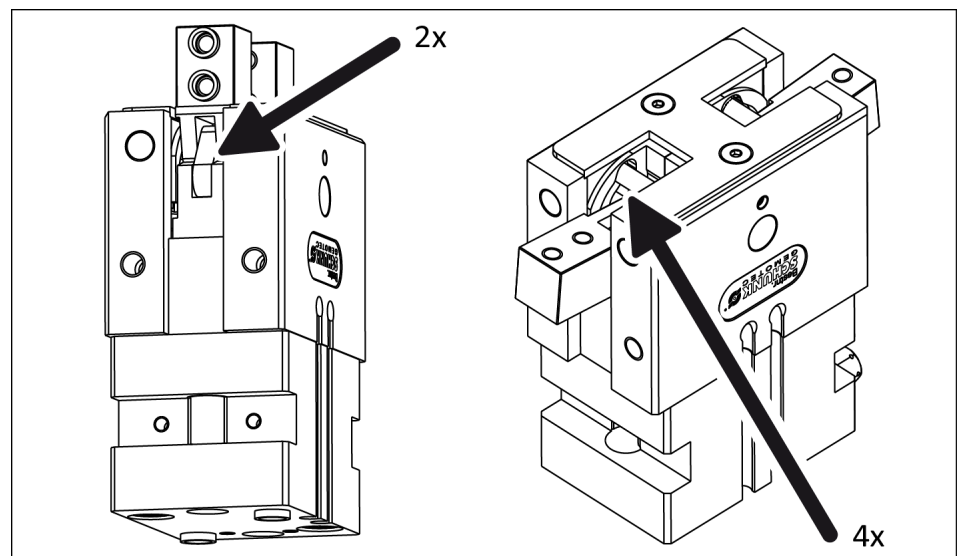

Greasing areas, lever mechanism and connecting members

If the product gets dirty, wipe it carefully with a soft cloth. Do not use solvents.

During maintenance, treat all greased areas with lubricant. Thinly apply lubricant with a lint-free cloth.

7.4 Disassembly and assembly

7.4.1 Variant with maintenance of gripping force

Position of the item numbers, ▶ 7.5 [34]



⚠ WARNING

Risk of injury due to unexpected movements!

If the power supply is switched on or residual energy remains in the system, components can move unexpectedly and cause serious injuries.

- Before starting any work on the product: Switch off the power supply and secure against restarting.
- Make sure, that no residual energy remains in the system.



⚠ WARNING

Risk of injury due to spring forces!

For products with gripping force maintenance, parts are under spring tension. During disassembly parts may move unexpectedly and cause serious injuries

- Disassemble the product cautiously.
- Make sure that no residual energy remains in the system.

1. Remove the compressed air line.
2. Carefully clamp the product between the base body (51) and the base body (21).
3. Remove screws (57) and (157).
4. Slowly unclamp springs.
5. Remove housing.
6. If applicable, disassemble the product further, ▶ 7.5 [34].

Assembly takes place in the opposite order to disassembly.

Observe the following:

- Unless otherwise specified, secure all screws and nuts with Loctite no. 243 and tighten with the appropriate tightening torque.

7.4.2 Variant without maintenance of gripping force

Position of the item numbers, ▶ 7.5 [📄 34]

1. Remove the compressed air lines.
2. Unfasten screws (46) and (143).
3. Remove base body (41).
4. If applicable, disassemble the product further, ▶ 7.5 [📄 34].

Assembly takes place in the opposite order to disassembly.

Observe the following:

- Unless otherwise specified, secure all screws and nuts with Loctite no. 243 and tighten with the appropriate tightening torque.

7.5 Assembly drawing

The following figure is an example image.
It serves for illustration and assignment of the spare parts.
Variations are possible depending on size and variant.

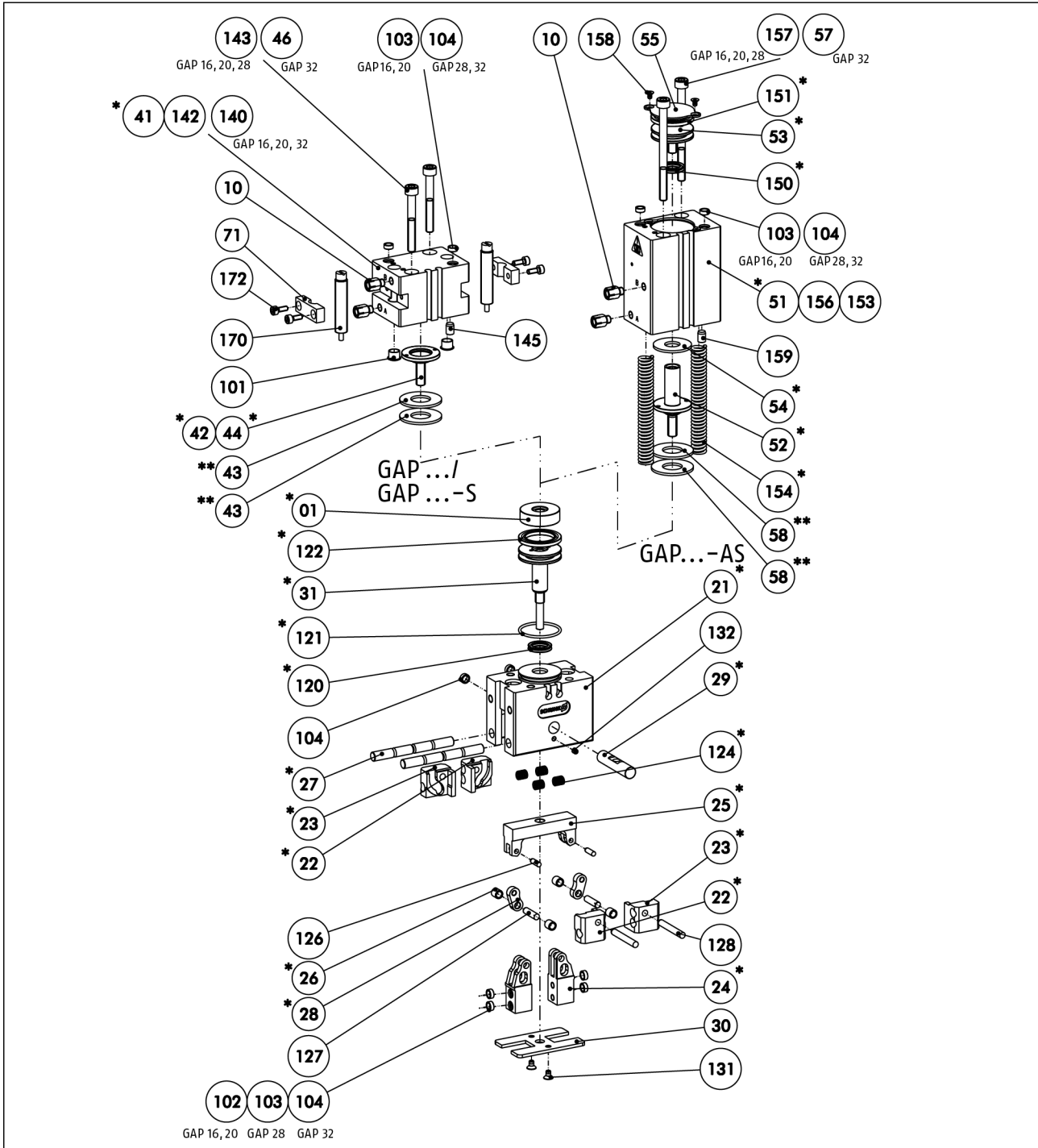

Assembly drawing

* Wearing part, replace during maintenance.

** Magnet orientation (43);(58):
Alignment of the south poles toward the gripper head (size 16 and 20)
Alignment of the south poles toward one another (size 18 and 32)

8 Translation of the original declaration of incorporation

in terms of the Directive 2006/42/EG, Annex II, Part 1 Section B.

Manufacturer/
Distributor SCHUNK SE & Co. KG
Spanntechnik | Greiftechnik | Automatisierungstechnik
Bahnhofstr. 106 – 134
D-74348 Lauffen/Neckar

We hereby declare that the partly completed machine described below

Product designation: 2-finger angular/parallel gripper / GAP /pneumatic
ID number 0314600 ... 0314638

meets the following basic occupational health and safety of the Machinery Directive 2006/42/EC:

No. 1.1.1, No. 1.1.2, No. 1.1.3, No. 1.1.5, No. 1.3.2, No. 1.5.3, No. 1.5.4, No. 1.5.6, No. 1.5.8, No. 1.5.10, No. 1.5.11, No. 1.5.13

The partly completed machinery may not be put into operation until it has been confirmed that the machine into which the partly completed machinery is to be installed complies with the provisions of the Machinery Directive (2006/42/EC). The declaration shall be rendered invalid if modifications are made to the product.

Applied harmonized standards, especially:

EN ISO 12100:2010 Safety of machinery – General principles for design –
Risk assessment and risk reduction

The special technical documentation according to Annex VII, Part B, belonging to the partly completed machine, has been created.

Person authorized to compile the technical documentation:
Stefanie Walter, Address: see manufacturer's address

Signature: see original declaration

Lauffen/Neckar, March 2025

Dr.-Ing. Manuel Baumeister,
Head of Systems Engineering,
Technology & Innovation

10 Information on the RoHS Directive, REACH Regulation and Substances of Very High Concern (SVHC)

RoHS Directive

SCHUNK products are classified as "large-scale stationary installations" or as "large-scale stationary industrial tools" within the meaning of Directive 2011/65/EU and its extension 2015/863/EU "on the restriction of the use of certain hazardous substances in electrical and electronic equipment (RoHS)", or fulfill their intended function only as part of one. Therefore products from SCHUNK do not fall within the scope of the directive at this time.

REACH Regulation

Products from SCHUNK fully comply with the regulations of Regulation (EC) No. 1907/2006 "concerning the Registration, Evaluation, Authorization and Restriction of Chemicals (REACH)" and its amendment 2022/477. SCHUNK attaches great importance to completely avoiding chemicals of concern to humans and the environment wherever possible.

Only in rare exceptional cases do SCHUNK products contain SVHC substances on the candidate list with a mass content above 0.1%. In accordance with Article. 33 (1) of Regulation (EC) No. 1907/2006, SCHUNK complies with its duty to "communicate information on substances in articles" and lists the components concerned and the substances used in an overview that can be viewed at schunk.com/SVHC.

Signature: see original declaration

Lauffen/Neckar, March 2025

Dr.-Ing. Manuel Baumeister,
Head of Systems Engineering,
Technology & Innovation

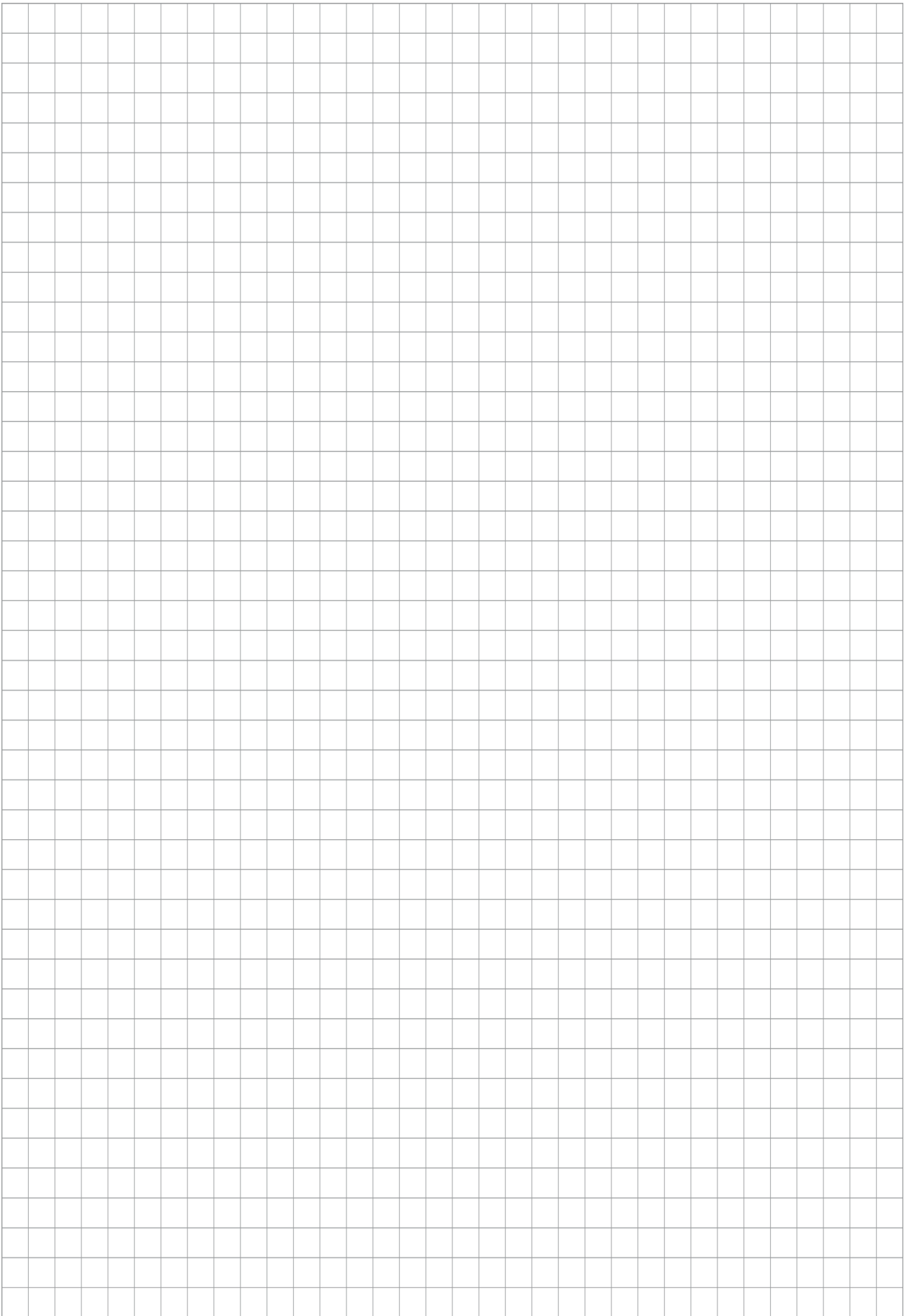





SCHUNK SE & Co. KG
Spanntechnik | Greiftechnik | Automatisierungstechnik

Bahnhofstr. 106 - 134
D-74348 Lauffen/Neckar
Tel. +49-7133-103-0
info@de.schunk.com
schunk.com

Folgen Sie uns | *Follow us*



Wir drucken nachhaltig | *We print sustainable*