



KONTEC KSX

Power-amplified-5-axis clamping vise

Superior Clamping and Gripping



Product Overview



Gripping Systems

Clamping Technology



Chuck Jaws



Lathe Chucks



Stationary Workholding



Toolholders



Hydraulic Expansion Technology



VERO-S



TANDEM



ROTA



KONTEC



Tombstones



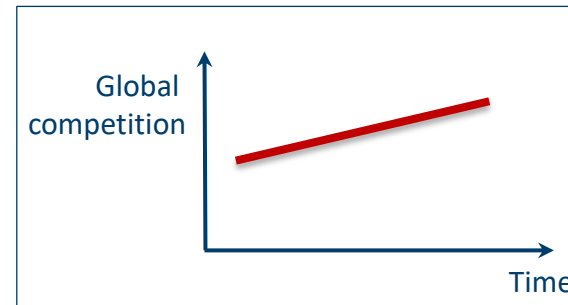
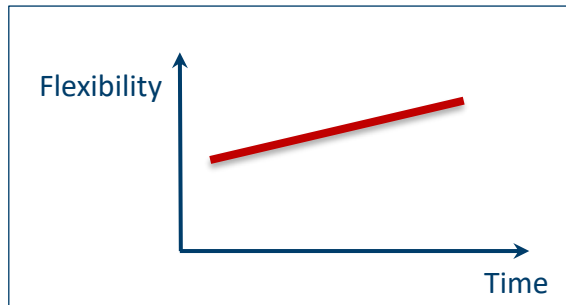
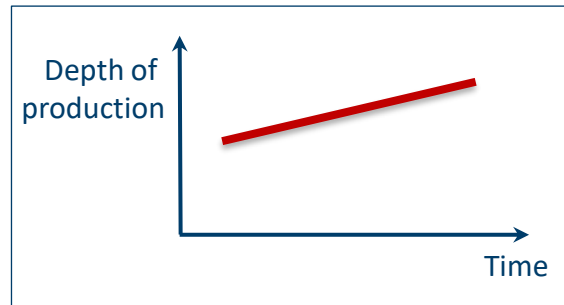

MAGNOS

Challenges



**Increasing importance
of workpiece clamping**





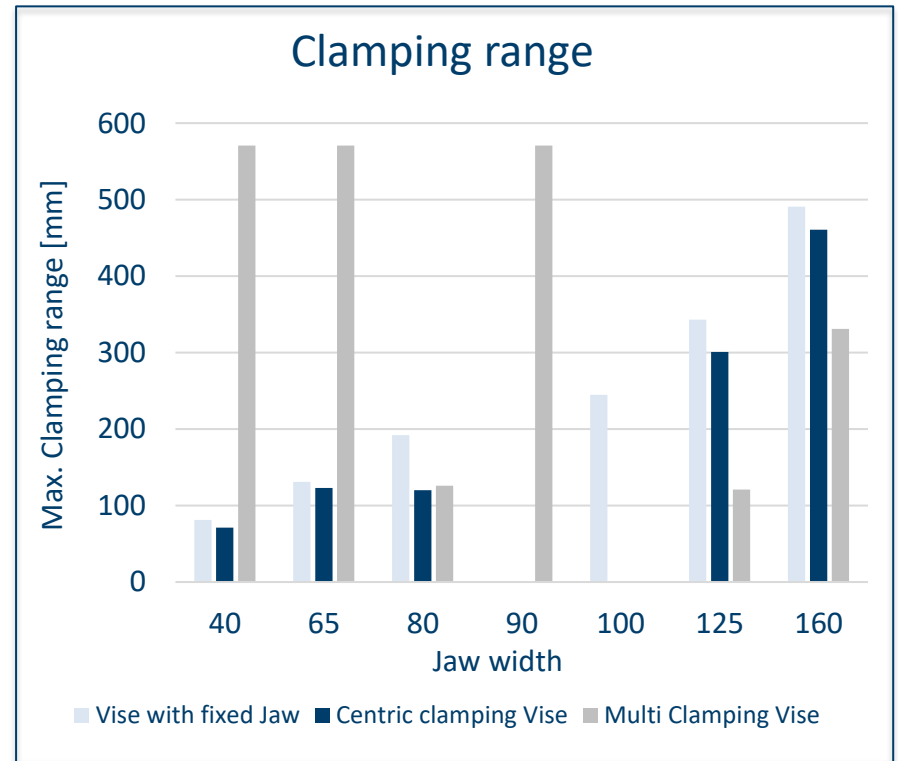
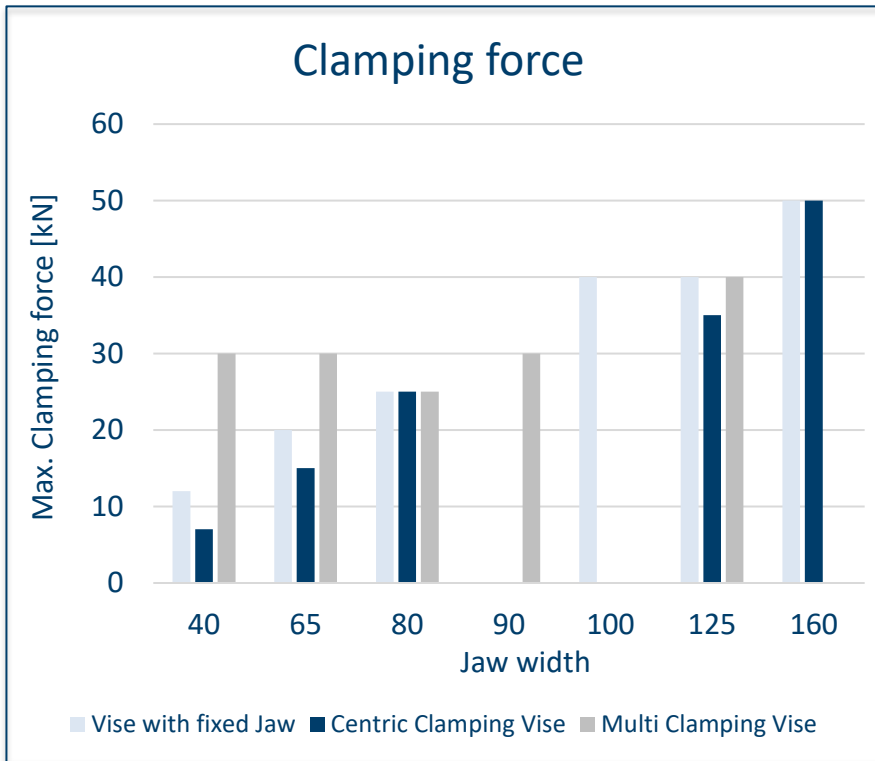

KONTEC Portfolio

Single-acting Vise	Centric Clamping Vise	Multi Clamping Vise
		
<ul style="list-style-type: none"> • Clamping towards a fixed jaw • Fixed jaw as reference • High repeat accuracy • Especially suitable for workpieces with dimensioning from the side 	<ul style="list-style-type: none"> • Symmetric clamping • Workpiece zero point is always in the center • Optimum accessibility for 5-axis milling • Especially suitable for workpieces with dimensioning from the center 	<ul style="list-style-type: none"> • Clamping of multiple workpieces • Multifunctional usage • Reduction of setup times • Optimum usage of the machine table

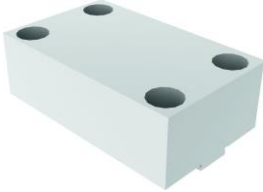
KONTEC Portfolio

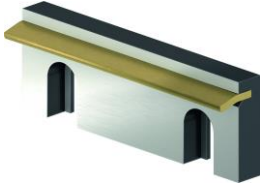

Fast adaption to new clamping tasks

System Jaws			
Standard reversible jaw	Reversible jaw, grip -grip	Enlarged span width -VS	Aluminium jaw -AL
			
Adapter- and swivel plates -R	5-axis standard jaw -5A / -5A-VS	6-fold jaw -6B	Reversible jaw grip, smooth central jaw -ST
			
Chuck Jaws			
Chuck jaw with locator pin	Spring plate, pull-down jaw	Prismatic jaw	Stepped jaw, grip
			

KONTEC Overview

Single-acting Vise



Centric Clamping Vise

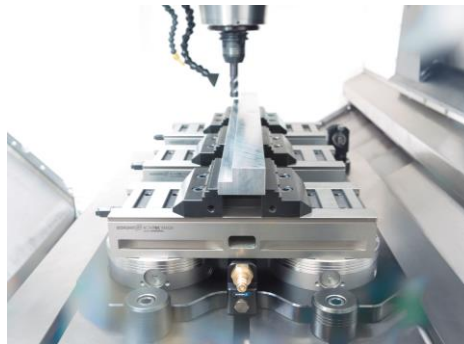

Multi Clamping Vise



KONTEC Single-acting Vise

With force amplification

KSG
Machine vise



KSX
5-axis clamping vise



Without force amplification

KSC-F
Basic clamping vise



KSO
Clamping vise for small components



KONTEC KSX

Example of application



KONTEC KSX



- 1 High precision
- 2 Mechanical force transmission
- 3 Lever quick clamping
- 4 Continuous clamping force adjustment
- 5 Complete encapsulation + quick adjustment
- 6 Optimal accessibility
- 7 Diverse applications

KONTEC KSX

Lever quick clamping



Continuously adjustable clamping force



Completely encapsulated force transmission box

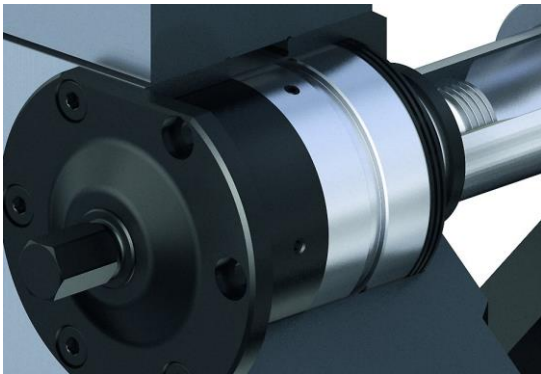

Clamping by tension

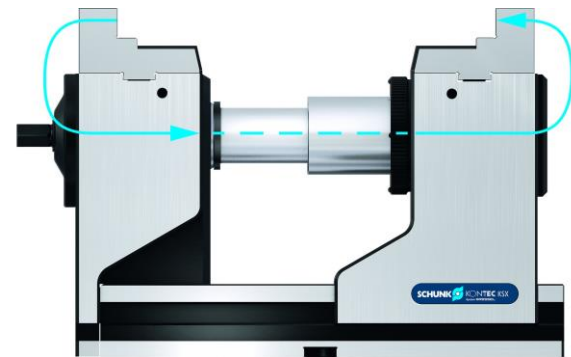

KONTEC KSX

Force transmission on equal level with the clamping position

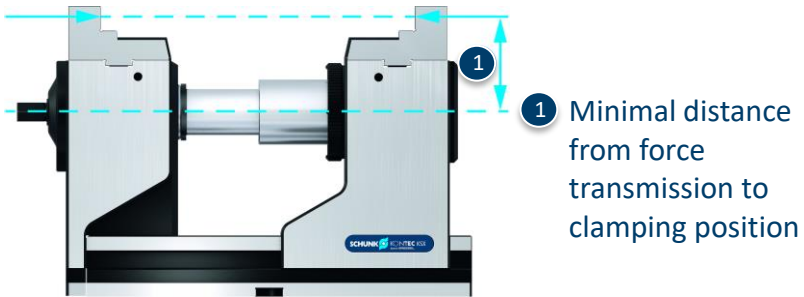

Mounting options

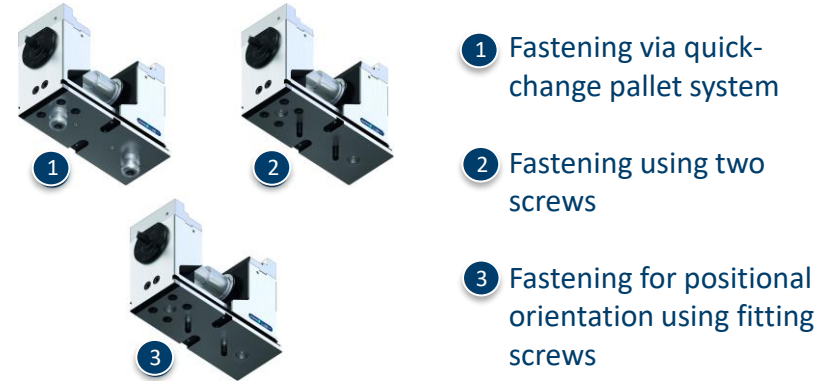

Low version



Can be extended to any length – maximum flexibility

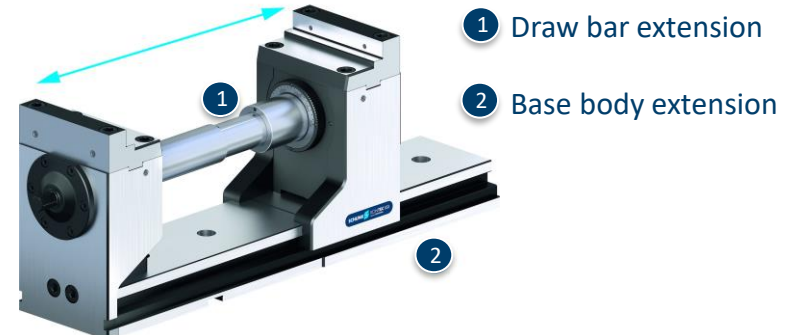

Variants of KONTEC KSX

Technical data	KSX 125		KSX AL 125		KSX R 125		KSX 6B 125		KSX ZV*	
Jaw width [mm]	125		125				125		125	
Height [mm]	174	125	174	125	174	125	174	125	174	125
Clamping force [kN]	5 - 40		5 - 40		5 - 40		5 - 40		5 - 40	
Weight [kg]	30.2	22.6	30.2	22.6	30.2	22.6	30.2	22.6	30.2	22.6

* Draw bar extension available in 125, 250, 375, 500 mm

Superior Clamping and Gripping



© 2021 SCHUNK GmbH & Co. KG
schunk.com