

Assembly and Operating Manual

LOG

Hole Gripper

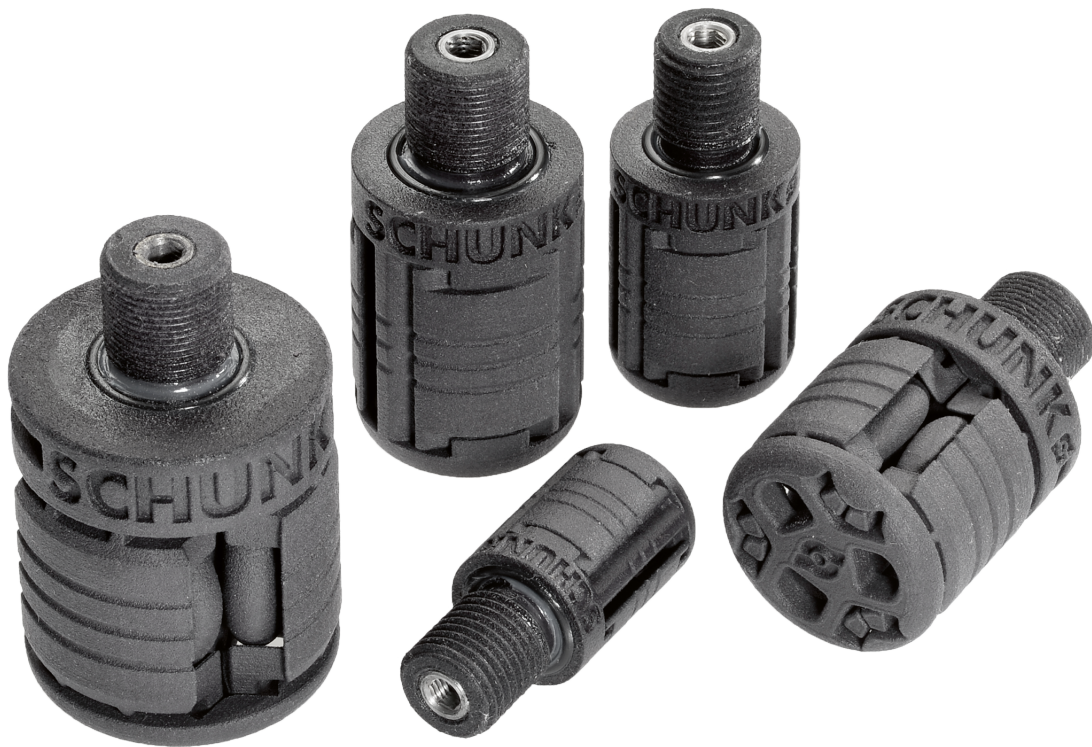

Superior Clamping and Gripping



Imprint

Copyright:

This manual is protected by copyright. The author is SCHUNK GmbH & Co. KG. All rights reserved.

Technical changes:

We reserve the right to make alterations for the purpose of technical improvement.

Document number: 389509

Version: 05.00 | 16/01/2023 | en

Dear Customer,

Thank you for trusting our products and our family-owned company, the leading technology supplier of robots and production machines.

Our team is always available to answer any questions on this product and other solutions. Ask us questions and challenge us. We will find a solution!

Best regards,

Your SCHUNK team

Customer Management

Tel. +49-7133-103-2503

Fax +49-7133-103-2189

cmg@de.schunk.com



Please read the operating manual in full and keep it close to the product.

Table of Contents

1	General	4
1.1	About this manual.....	4
1.1.1	Presentation of Warning Labels.....	4
1.1.2	Applicable documents	5
1.2	Warranty.....	5
1.3	Scope of delivery.....	6
1.4	Accessories.....	6
2	Basic safety notes	7
2.1	Intended use	7
2.2	Constructional changes.....	7
2.3	Spare parts	7
2.4	Gripper fingers	8
2.5	Environmental and operating conditions	8
2.6	Personnel qualification	9
2.7	Personal protective equipment	9
2.8	Notes on safe operation	10
2.9	Transport.....	10
2.10	Malfunctions	10
2.11	Disposal.....	10
2.12	Fundamental dangers	11
2.12.1	Protection during handling and assembly	11
2.12.2	Protection during commissioning and operation	11
2.12.3	Protection against dangerous movements.....	12
2.12.4	Protection against electric shock	12
2.13	Notes on particular risks	13
3	Technical Data	14
4	Assembly	15
4.1	Mechanical connection	15
4.2	Air connections	16
5	Troubleshooting	17
5.1	Product does not move?.....	17
5.2	The product does not travel through the entire stroke?	17
5.3	Product opens or closes abruptly?.....	17
5.4	The gripping force drops?	17
5.5	Product does not achieve the opening and closing times?.....	17
6	Maintenance and Care	18
7	Translation of the original declaration of incorporation	19
8	UKCA declaration of incorporation	20
9	Annex to declaration of Incorporation	21

1 General

1.1 About this manual

This manual contains important information for a safe and appropriate use of the product.

This manual is an integral part of the product and must be kept accessible for the personnel at all times.

Before starting work, the personnel must have read and understood this operating manual. Prerequisite for safe working is the observance of all safety instructions in this manual.

In addition to these instructions, the documents listed under ▶ 1.1.2 [□ 5] are applicable.

NOTE: The illustrations in this manual are intended to provide a basic understanding and may deviate from the actual version.

1.1.1 Presentation of Warning Labels

To make risks clear, the following signal words and symbols are used for safety notes.



⚠ DANGER

Dangers for persons!

Non-observance will inevitably cause irreversible injury or death.



⚠ WARNING

Dangers for persons!

Non-observance can lead to irreversible injury and even death.



⚠ CAUTION

Dangers for persons!

Non-observance can cause minor injuries.

NOTICE

Material damage!

Information about avoiding material damage.

1.1.2 Applicable documents

- General terms of business *
- Catalog data sheet of the purchased product *
- Assembly and operating manuals of the accessories *

The documents labeled with an asterisk (*) can be downloaded from [schunk.com](https://www.schunk.com).

1.2 Warranty

If the product is used as intended, the warranty is valid for 24 months from the ex-works delivery date under the following conditions:

- Observe the applicable documents, ▶ [1.1.2 \[5 \]](#)
- Observe the ambient conditions and operating conditions, ▶ [2.5 \[8 \]](#)
- Observe the maximum service life. ▶ [3 \[14 \]](#)
- Observe the specified maintenance and lubrication intervals, ▶ [6 \[18 \]](#)

Wearing surfaces that come into contact with the workpiece are excluded from the warranty.

At high temperatures a shorter life span can be expected.

The product is not considered defective if it warps plastically within the specified limits. The permissible warp is dependent on the workpiece diameter.

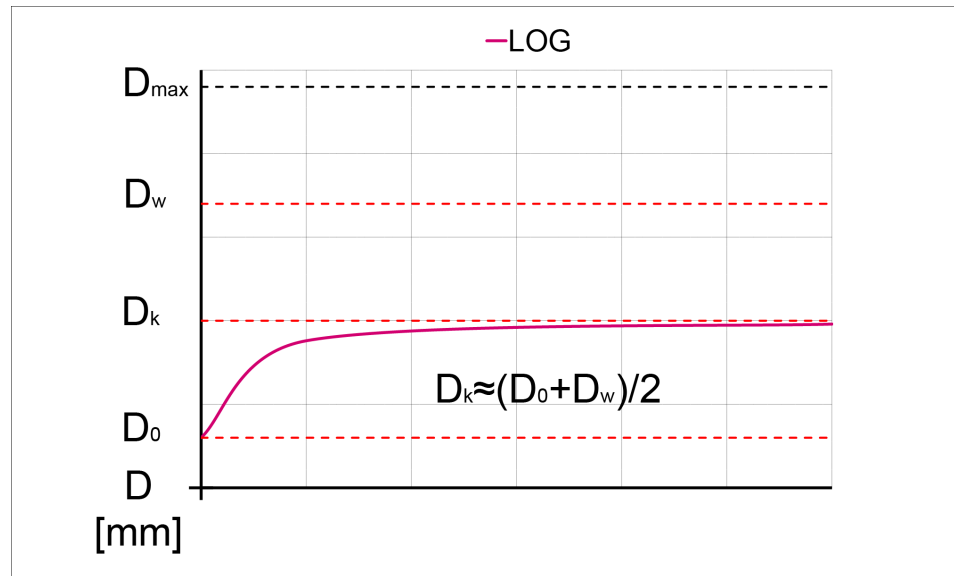

Symbol [mm]	Designation
D_0	Gripper - $\emptyset D$
D_k	Max. value to which the gripper - $\emptyset D$ creeps
D_w	Workpiece diameter
D_{max}	Max. workpiece diameter

1.3 Scope of delivery

The scope of delivery includes

- Hole Gripper LOG in the version ordered
- Assembly and Operating Manual

1.4 Accessories

A wide range of accessories are available for this product. For information regarding which accessory articles can be used with the corresponding product variants, see catalog data sheet.

2 Basic safety notes

2.1 Intended use

The product is designed exclusively for gripping and temporarily holding workpieces or objects.

- The product may only be used within the scope of its technical data, ▶ 3 [□ 14].
- The product is intended for installation in a machine/automated system. The applicable guidelines for the machine/automated system must be observed and complied with.
- The product is intended for industrial and industry-oriented use. Its use outside enclosed spaces is only permitted if suitable protective measures are taken against outdoor exposure. The product is not suitable for use in salty air.
- The product can be used within the permissible load limits and technical data for holding workpieces during simple machining operations, but is not a clamping device according to EN 1550:1997+A1:2008.
- Appropriate use of the product includes compliance with all instructions in this manual.
- Any utilization that exceeds or differs from the appropriate use is regarded as misuse.

2.2 Constructional changes

Implementation of structural changes

By conversions, changes, and reworking, e.g. additional threads, holes, or safety devices can impair the functioning or safety of the product or damage it.

- Structural changes should only be made with the written approval of SCHUNK.

2.3 Spare parts

Use of unauthorized spare parts

Using unauthorized spare parts can endanger personnel and damage the product or cause it to malfunction.

- Use only original spare parts or spares authorized by SCHUNK.

2.4 Gripper fingers

Requirements of gripper fingers

Accumulated energy can make the product unsafe and risk the danger of serious injuries and considerable material damage.

- Execute the gripper fingers in such a way that the product reaches either the "open" or "closed" position in a de-energized state.
- Only change gripper fingers if no residual energy can be released.
- Make sure that the product and the top jaws are a sufficient size for the application.

2.5 Environmental and operating conditions

- Make sure that the product and the top jaws are a sufficient size for the application.
- Ensure that the environment is clean.
- Make sure that the environment is free from splash water and vapors as well as from abrasion or processing dust. This excludes products that are designed specially for contaminated environments.
- Prevent the LOG hole grippers remain pressurized with compressed air for a long time (> 1 hour) (e.g. in case of machine shutdown or overnight). In addition, idle strokes (opening the gripper without a workpiece) are to be avoided.
- For production reasons, it is possible that powder granules come loose on the gripper (inside and outside) during operation. Therefore, the use of a filter for the compressed air is recommended.

2.6 Personnel qualification

Inadequate qualifications of the personnel

If the personnel working with the product is not sufficiently qualified, the result may be serious injuries and significant property damage.

- All work may only be performed by qualified personnel.
- Before working with the product, the personnel must have read and understood the complete assembly and operating manual.
- Observe the national safety regulations and rules and general safety instructions.

The following personal qualifications are necessary for the various activities related to the product:

Trained electrician	Due to their technical training, knowledge and experience, trained electricians are able to work on electrical systems, recognize and avoid possible dangers and know the relevant standards and regulations.
Qualified personnel	Due to its technical training, knowledge and experience, qualified personnel is able to perform the delegated tasks, recognize and avoid possible dangers and knows the relevant standards and regulations.
Instructed person	Instructed persons were instructed by the operator about the delegated tasks and possible dangers due to improper behaviour.
Service personnel of the manufacturer	Due to its technical training, knowledge and experience, service personnel of the manufacturer is able to perform the delegated tasks and to recognize and avoid possible dangers.

2.7 Personal protective equipment

Use of personal protective equipment

Personal protective equipment serves to protect staff against danger which may interfere with their health or safety at work.

- When working on and with the product, observe the occupational health and safety regulations and wear the required personal protective equipment.
- Observe the valid safety and accident prevention regulations.
- Wear protective gloves to guard against sharp edges and corners or rough surfaces.
- Wear heat-resistant protective gloves when handling hot surfaces.
- Wear protective gloves and safety goggles when handling hazardous substances.
- Wear close-fitting protective clothing and also wear long hair in a hairnet when dealing with moving components.

2.8 Notes on safe operation

Incorrect handling of the personnel

Incorrect handling and assembly may impair the product's safety and cause serious injuries and considerable material damage.

- Avoid any manner of working that may interfere with the function and operational safety of the product.
- Use the product as intended.
- Observe the safety notes and assembly instructions.
- Do not expose the product to any corrosive media. This does not apply to products that are designed for special environments.
- Eliminate any malfunction immediately.
- Observe the care and maintenance instructions.
- Observe the current safety, accident prevention and environmental protection regulations regarding the product's application field.

2.9 Transport

Handling during transport

Incorrect handling during transport can make the product unsafe and risk the danger of serious injuries and considerable material damage.

- During transport and handling, secure the product to prevent it from falling.
- Do not walk under suspended loads.

2.10 Malfunctions

Behavior in case of malfunctions

- Immediately remove the product from operation and report the malfunction to the responsible departments/persons.
- Order appropriately trained personnel to rectify the malfunction.
- Do not recommission the product until the malfunction has been rectified.
- Test the product after a malfunction to establish whether it still functions properly and no increased risks have arisen.

2.11 Disposal

Handling of disposal

The incorrect handling of disposal may impair the product's safety and cause serious injuries as well as considerable material and environmental harm.

- Follow local regulations on dispatching product components for recycling or proper disposal.

2.12 Fundamental dangers

General

- Observe safety distances.
- Never deactivate safety devices.
- Before commissioning the product, take appropriate protective measures to secure the danger zone.
- Disconnect power sources before installation, modification, maintenance, or calibration. Ensure that no residual energy remains in the system.
- If the energy supply is connected, do not move any parts by hand.
- Do not reach into the open mechanism or movement area of the product during operation.

2.12.1 Protection during handling and assembly

Incorrect handling and assembly

Incorrect handling and assembly may impair the product's safety and cause serious injuries and considerable material damage.

- Have all work carried out by appropriately qualified personnel.
- For all work, secure the product against accidental operation.
- Observe the relevant accident prevention rules.
- Use suitable assembly and transport equipment and take precautions to prevent jamming and crushing.

Incorrect lifting of loads

Falling loads may cause serious injuries and even death.

- Stand clear of suspended loads and do not step into their swiveling range.
- Never move loads without supervision.
- Do not leave suspended loads unattended.

2.12.2 Protection during commissioning and operation

Falling or violently ejected components

Falling and violently ejected components can cause serious injuries and even death.

- Take appropriate protective measures to secure the danger zone.
- Never step into the danger zone during operation.

2.12.3 Protection against dangerous movements

Unexpected movements

Residual energy in the system may cause serious injuries while working with the product.

- Switch off the energy supply, ensure that no residual energy remains and secure against inadvertent reactivation.
- Never rely solely on the response of the monitoring function to avert danger. Until the installed monitors become effective, it must be assumed that the drive movement is faulty, with its action being dependent on the control unit and the current operating condition of the drive. Perform maintenance work, modifications, and attachments outside the danger zone defined by the movement range.
- To avoid accidents and/or material damage, human access to the movement range of the machine must be restricted. Limit/prevent accidental access for people in this area due through technical safety measures. The protective cover and protective fence must be rigid enough to withstand the maximum possible movement energy. EMERGENCY STOP switches must be easily and quickly accessible. Before starting up the machine or automated system, check that the EMERGENCY STOP system is working. Prevent operation of the machine if this protective equipment does not function correctly.

2.12.4 Protection against electric shock

Possible electrostatic energy

Components or assembly groups may become electrostatically charged. When the electrostatic charge is touched, the discharge may trigger a shock reaction leading to injuries.

- The operator must ensure that all components and assembly groups are included in the local potential equalisation in accordance with the applicable regulations.
- While paying attention to the actual conditions of the working environment, the potential equalisation must be implemented by a specialist electrician according to the applicable regulations.
- The effectiveness of the potential equalisation must be verified by executing regular safety measurements.

2.13 Notes on particular risks



⚠ WARNING

Risk of injury from objects falling and being ejected!

Falling and ejected objects during operation can lead to serious injury or death.

- Take appropriate protective measures to secure the danger zone.



⚠ CAUTION

Danger of crushing between the gripper housing and base jaws

Fingers or body parts can be crushed if they get into the openings between the gripper housing and base jaws during operation.

- When the air supply is connected, do not reach into the openings between the gripper housing and base jaws.

3 Technical Data

Technical Data

Designation	LOG 20 - 99
Pressure medium	Compressed air, compressed air quality according to ISO 8573-1:7 4 4
Nominal working pressure [bar]	6
Max. pressure [bar]	6
Noise emission [dB(A)]	≤ 70

The gripping force can be set directly by the operating pressure. At a lower pressure than the nominal operating pressure, the full stroke cannot be achieved.

Warranty

Designation	LOG 20 - 99
Warranty duration [months]	24
or maximum cycles [piece]	5.000.000

More technical data is included in the catalog data sheet. Whichever is the latest version.

4 Assembly

4.1 Mechanical connection

Evenness of the mounting surface

The values apply to the whole mounting surface to which the product is mounted.

Requirements for evenness of the mounting surface (Dimensions in mm)

Edge length	Permissible unevenness
< 100	< 0.02
> 100	< 0.05

Mounting

The product can be mounted in a threaded hole or a through-hole with a corresponding counter nut.

SCHUNK recommends a 1 mm larger through-hole for mounting the gauge block to be able to align the gripper.

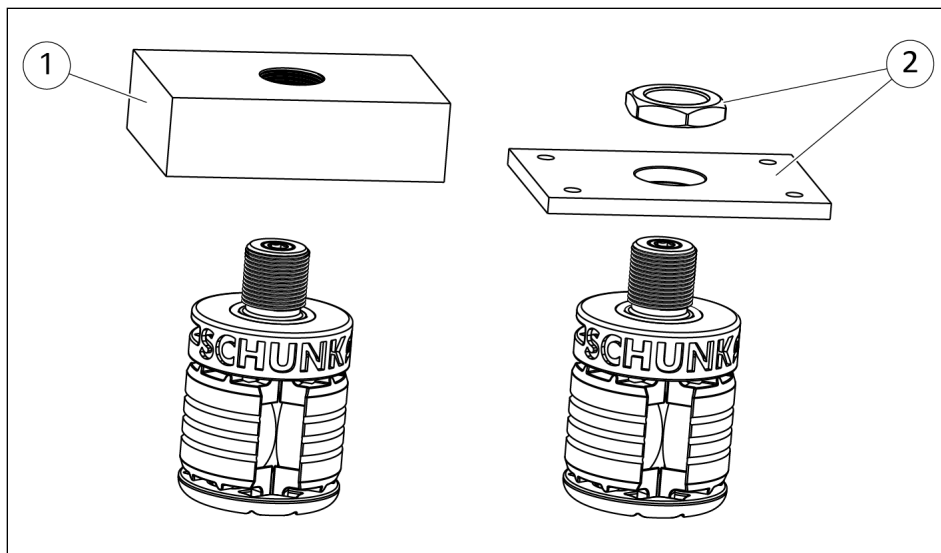

Assembly options

1	Mounting with threaded hole
2	Mounting with through-hole and nut (preferred variant for gauge block mounting)

Mounting thread

Designation	LOG		
	20 – 25	26 – 63	64 – 99
Mounting thread on the product	M14 x 1.5	M16 x 1	M20 x 1.5
Length [mm]	17		

4.2 Air connections

NOTICE

Observe the requirements for the air supply
 ▶ 3 [14].

The product has an air connection, but has two ways of supplying air.

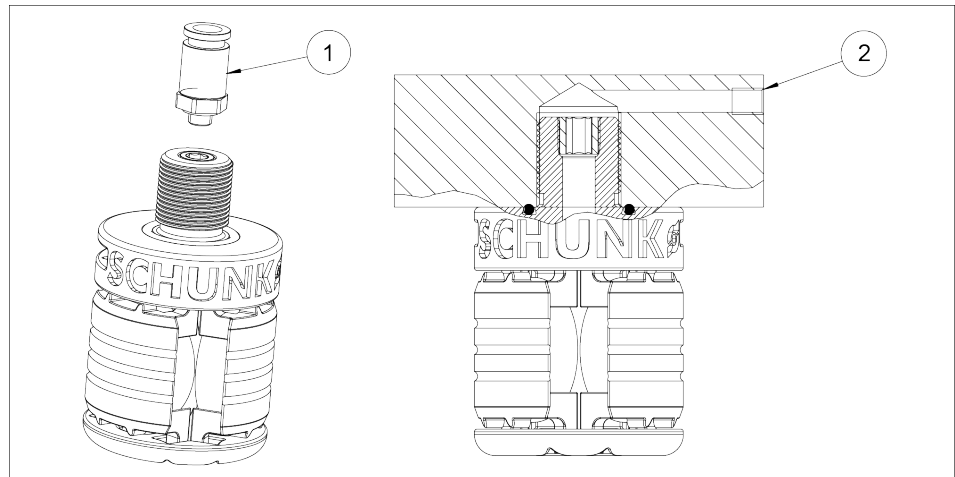

Air connections

1	Air connection from above (hose connection) M5 (LOG 20 - 63) and G 1/8' (LOG 64 - 99)
2	Internal air supply (hose-free direct connection) The connection is sealed by the O-ring. A suitable surface finish in the plate is required.

5 Troubleshooting

5.1 Product does not move?

Possible cause	Corrective action
Pressure drops below minimum.	Check air supply. ▶ 4.2 [□ 16]
Component part defective.	Replace the gripper completely. Make sure that the product was only used in the context of its defined application parameters ▶ 3 [□ 14].

5.2 The product does not travel through the entire stroke?

Possible cause	Corrective action
Dirt deposits between the end stops	Clean the product.
Pressure drops below minimum.	Check air supply. ▶ 4.2 [□ 16]
Mounting surface is not sufficiently flat.	Check the evenness of the mounting surface. ▶ 4.1 [□ 15]
Component part defective.	Replace the gripper completely.

5.3 Product opens or closes abruptly?

Possible cause	Corrective action
Compressed air lines blocked.	Check compressed air lines of damage.

5.4 The gripping force drops?

Possible cause	Corrective action
Compressed air can escape.	Check seals, replace product if necessary.
Pressure drops below minimum.	Check air supply. ▶ 4.2 [□ 16]

5.5 Product does not achieve the opening and closing times?

Possible cause	Corrective action
Compressed air lines are not installed optimally.	Check compressed air lines. Inner diameters of compressed air lines are of sufficient size in relation to compressed air consumption. Keep compressed air lines between the product and directional control valve as short as possible. Flow rate of valve is sufficiently large relative to the compressed air consumption.

6 Maintenance and Care

The product is not intended for maintenance.

Disassembly for maintenance or repair purposes is not possible.

A damaged product has to be replaced completely.

8 UKCA declaration of incorporation

in accordance with the Supply of Machinery (Safety) Regulations 2008.

Manufacturer/
Distributor SCHUNK Intec Limited
 Clamping and gripping technology
 3 Drakes Mews, Crownhill
 MK8 OER Milton Keynes

We hereby declare that on the date of the declaration the following partly completed machine complied with all basic safety and health regulations found in the "Supply of Machinery (Safety) Regulations 2008".

The declaration shall be rendered invalid if modifications are made to the product.

Product designation: Hole Gripper / LOG / pneumatic
ID number 0398920 ... 0398999

The partly completed machine may not be put into operation until it has been confirmed that the machine into which the partly completed machine is to be installed complies with the provisions of the "Supply of Machinery (Safety) Regulations 2008".

Applied harmonized standards, especially:

EN ISO 12100:2010 Safety of machinery - General principles for design -
 Risk assessment and risk reduction

The manufacturer agrees to forward on demand the relevant technical documentation for the partly completed machinery in electronic form to national authorities.

The relevant technical documentation according to Annex VII, Part B, belonging to the partly completed machinery, has been created.

Person authorized to compile the technical documentation:
Marcel Machado, address: refer to manufacturer's address



Lauffen/Neckar, January 2023

p.p. Ralf Winkler;
Head of Technology & Engineering,
Mechanics Gripping Systems

9 Annex to declaration of Incorporation

in accordance with 2006/42/EC, Appendix II, no. 1 B

as well as

in accordance with the Supply of Machinery (Safety) Regulations 2008.

1. Description of the basic safety and health protection requirements, as per 2006/42/EC, Annex I and per the Supply of Machinery (Safety) Regulations 2008, that apply to and are fulfilled for the scope of the incomplete machine:

Product designation	Hole Gripper
Type designation	LOG
ID number	0398920 ... 0398999

To be provided by the System Integrator for the overall machine	↓
Fulfilled for the scope of the partly completed machine	↓
Not relevant	↓

1.1	Essential Requirements		
1.1.1	Definitions	X	
1.1.2	Principles of safety integration	X	
1.1.3	Materials and products	X	
1.1.4	Lighting	X	
1.1.5	Design of machinery to facilitate its handling	X	
1.1.6	Ergonomics	X	
1.1.7	Operating positions		X
1.1.8	Seating		X

1.2	Control Systems		
1.2.1	Safety and reliability of control systems	X	
1.2.2	Control devices	X	
1.2.3	Starting	X	
1.2.4	Stopping	X	
1.2.4.1	Normal stop	X	
1.2.4.2	Operational stop	X	
1.2.4.3	Emergency stop	X	
1.2.4.4	Assembly of machinery	X	
1.2.5	Selection of control or operating modes	X	
1.2.6	Failure of the power supply		X

1.3	Protection against mechanical hazards		
1.3.1	Risk of loss of stability		X
1.3.2	Risk of break-up during operation		X

1.3	Protection against mechanical hazards			
1.3.3	Risks due to falling or ejected objects			X
1.3.4	Risks due to surfaces, edges or angles		X	
1.3.5	Risks related to combined machinery			X
1.3.6	Risks related to variations in operating conditions			X
1.3.7	Risks related to moving parts		X	
1.3.8	Choice of protection against risks arising from moving parts			X
1.3.8.1	Moving transmission parts		X	
1.3.8.2	Moving parts involved in the process			X
1.3.9	Risks of uncontrolled movements			X
1.4	Required characteristics of guards and protective devices			
1.4.1	General requirements			X
1.4.2	Special requirements for guards			X
1.4.2.1	Fixed guards			X
1.4.2.2	Interlocking movable guards			X
1.4.2.3	Adjustable guards restricting access			X
1.4.3	Special requirements for protective devices			X
1.5	Risks due to other hazards			
1.5.1	Electricity supply		X	
1.5.2	Static electricity		X	
1.5.3	Energy supply other than electricity		X	
1.5.4	Errors of fitting		X	
1.5.5	Extreme temperatures			X
1.5.6	Fire			X
1.5.7	Explosion			X
1.5.8	Noise			X
1.5.9	Vibrations			X
1.5.10	Radiation	X		
1.5.11	External radiation	X		
1.5.12	Laser radiation	X		
1.5.13	Emissions of hazardous materials and substances			X
1.5.14	Risk of being trapped in a machine	X		
1.5.15	Risk of slipping, tripping or falling	X		
1.5.16	Lightning			X
1.6	Maintenance			
1.6.1	Machinery maintenance		X	
1.6.2	Access to operating positions and servicing points		X	
1.6.3	Isolation of energy sources		X	

1.6	Maintenance			
1.6.4	Operator intervention		X	
1.6.5	Cleaning of internal parts		X	
1.7	Information			
1.7.1	Information and warnings on the machinery		X	
1.7.1.1	Information and information devices		X	
1.7.1.2	Warning devices		X	
1.7.2	Warning of residual risks		X	
1.7.3	Marking of machinery	X		
1.7.4	Instructions	X		
1.7.4.1	General principles for the drafting of instructions	X		
1.7.4.2	Contents of the instructions	X		
1.7.4.3	Sales literature	X		
	The classification from Annex 1 is to be supplemented from here forward.			
2	Supplementary essential health and safety requirements for certain categories of machinery			X
2.1	Foodstuffs machinery and machinery for cosmetics or pharmaceutical products			X
2.2	Portable hand-held and/or guided machinery			X
2.2.1	Portable fixing and other impact machinery			X
2.3	Machinery for working wood and material with similar physical characteristics			X
3	Supplementary essential health and safety requirements to offset hazards due to the mobility of machinery		X	
4	Supplementary essential health and safety requirements to offset hazards due to lifting operations		X	
5	Supplementary essential health and safety requirements for machinery intended for underground work			X
6	Supplementary essential health and safety requirements for machinery presenting particular hazards due to the lifting of persons		X	

SCHUNK GmbH & Co. KG
Clamping and gripping technology

Bahnhofstr. 106 - 134
D-74348 Lauffen/Neckar
Tel. +49-7133-103-0
Fax +49-7133-103-2399
info@de.schunk.com
schunk.com

Folgen Sie uns | *Follow us*

