

## Original Assembly and Maintenance Instructions

### Linear Unit

**HSB-delta**

#### Typen

Delta 90-SRS  
Delta 110-C-SSS  
Delta 145-C-SSS  
Delta 200-SSS  
Delta 240-SSS  
Delta 240-C-SSS

HSB Automation GmbH  
In Laisen 74  
72766 Reutlingen  
Deutschland  
Tel. +49 7121 14498-0  
info@HSB-Automation.de  
www.hsb-automation.de

Distributor:  
SCHUNK GmbH & Co. KG  
Spann- und Greiftechnik  
Bahnhofstr. 106 - 134  
74348 Lauffen/Neckar  
Deutschland  
Tel. +49 7133-103-0  
Fax +49 7133-103-2399  
info@de.schunk.com  
www.schunk.com



# Contents

<b>1</b>	<b>Safety</b> .....	<b>2</b>
1.1	Symbols used .....	2
1.2	Regulation use .....	2
1.3	General safety .....	3
1.5	Use in explosive environments .....	3
1.6	Technical condition of the linear unit.....	3
1.7	Modifications to the linear unit .....	4
1.8	Requirements for personnel.....	4
1.9	Responsibilities of the operator.....	4
<b>2</b>	<b>Warranty</b> .....	<b>5</b>
<b>3</b>	<b>Technical data – Standard model</b> .....	<b>6</b>
<b>4</b>	<b>Product description</b> .....	<b>11</b>
<b>5</b>	<b>Transportation and storage</b> .....	<b>14</b>
<b>6</b>	<b>Installation and adjustment</b> .....	<b>15</b>
6.1	Installing the linear unit by mounting rails .....	15
6.2	Screwing the linear unit into place from below (not Delta 90).....	16
6.3	Setting maximum travel .....	16
6.3.1	Setting the positions of the inductive limit switches .....	17
6.3.2	Setting the positions of the mechanical limit switches.....	18
6.4	Mounting a drive unit .....	19
6.4.1	Mounting a motor .....	20
<b>7</b>	<b>Start-up</b> .....	<b>21</b>
<b>8</b>	<b>Operation</b> .....	<b>22</b>
<b>9</b>	<b>Shutdown</b> .....	<b>22</b>
<b>10</b>	<b>Maintenance</b> .....	<b>23</b>
10.1	Lubrication.....	23
10.2	Replacing cover bands .....	27
10.3	Your added value in service: Repair and Retrofit.....	29

# 1 Safety

This operating manual is an integral part of the machine package, and must be kept permanently ready to hand as a reference source. It must be passed on with the machine if the machine is sold on.

If there is anything in this manual which you do not fully understand, please be sure to contact the manufacturers.

## 1.1 Symbols used

This manual employs the following symbols to indicate hazards as well as other types of symbol:

DANGER



Indicates immediate danger.  
Failure to observe this notice entails risk of death or very serious injury.

WARNING



Indicates a danger carrying a medium to high risk.  
Failure to observe this notice may result in death or serious injury.

CAUTION



Indicates minor risk.  
Failure to observe this notice may result in light to moderate injury or damage to property.

 Note  
Indicates tips on use of the machine and optimising its efficiency.

## 1.2 Regulation use

The mechanical linear unit is intended to be used solely for manipulating, positioning, transporting, palletising, loading, unloading, clamping, clacking, tensioning, testing, measuring, handling and pushing workpieces or tools.

Pay attention to the basic applications of the linear unit set out in sections 4 and 3.

In order to comply with the EU Directive governing Electromagnetic Compatibility (EMC), the mechanical linear unit may only be used in industrial environments, as defined in European standard EN 61000-6-1.

Any other use, or use for purposes beyond those stipulated, will be classed as illegitimate. The manufacturers accept no liability for any loss thereby incurred. The risk is borne solely by the operators.

## 1.3 General safety

### Preconditions for operation

The linear unit must not be put into operation until the machine or line into which it is installed conforms to the following:

- EC/EU directives
- Standards governing the electromagnetic compatibility of machinery

### Safe operation

To ensure safe operation, refer to the following documents:

- This operating manual for the linear unit, particularly the technical data
- The operating manual for the line into which it is installed

### Decommissioning

Dispose of the product in accordance with the applicable national requirements. Observe the safety data sheets.

## 1.4 Use in clean rooms (ISO 14644)

The linear units used in clean rooms are fitted with a vent hole (generally G1/4") at the basic profile.

The following guidelines must be observed:

- The linear unit must be subjected to a negative pressure of 0.2 bar.
- The linear unit must be relubricated with a grease suitable for use in clean rooms (basic lubrication carried out using Klübersynth BEM 32-34).

## 1.5 Use in explosive environments



The linear units are suitable for use in explosive atmospheres in zones according to their ATEX marking. In addition to these assembly and maintenance instructions, the document "[FM\\_319\\_Use-in-Atex-zones-MuW](#)" must also be observed.

## 1.6 Technical condition of the linear unit

### State of the art

- The unit conforms to the current state of the art and applicable rules and regulations. The device complies with the EC Machinery Directive and the relevant Harmonised Standards (European standards). Furthermore, the EC Declaration of Incorporation applies.

## 1.7 Modifications to the linear unit

### Modifications

The linear unit must not be modified, either in its basic design or in its safety components, without our written consent. Any such unauthorised modification will void our liability in respect of the unit.

The operating company may only carry out the maintenance and repair work detailed in this operating manual. Any other measures, such as to replace wearing parts and components, may be carried out only in consultation with our service engineers, by the service engineers themselves, or by us directly.

Installed safety devices must never be dismantled or disabled.

When fitting special attachments to the unit, follow the fitting instructions provided by the manufacturers!

## 1.8 Requirements for personnel

Work on parts carrying live electrical current may be carried out only by trained electricians. Such work includes:

- Installing safety limit switches
- Mounting a drive unit
- Checking the direction of rotation of the drive

## 1.9 Responsibilities of the operator

**Preservation of labels** The operator must ensure that any lettering, information signs or labels are fully legible (in particular the serial number) and always observed. Any damaged or illegible information signs and labels must be replaced.

**Accident Prevention and Environmental Protection** The applicable regulations for accident prevention and environmental protection must be observed.

**Disposal** Dispose of the product according to the relevant national regulations. Refer to the safety data sheets.

## 2 Warranty

The warranty conditions are laid down in the terms and conditions of delivery and payment issued at time of order. Warranty cover will be voided if:

- the unit is not operated in accordance with the stipulated regulation use;
- the instructions set out in this operating manual are not followed;
- the unit is modified without the consent of the manufacturers;
- screws sealed by locking varnish are unlocked.

The manufacturer's warranty in respect of maintenance and repair work applies only if original replacement parts are used.

### 3 Technical data – Standard model

Linear unit model Delta	Sizes			
	90		110-C	
	SRS		SSS	
Drive element	BSD <sup>2)</sup>	TSD <sup>3)</sup>	BSD <sup>2)</sup>	TSD <sup>3)</sup>
Max. speed [rpm]	3000	1500	3000	1500
Spindle diameter [mm]	12	12	16	16
Spindle pitch [mm]	5 10	3	5 10 20 40	4
Moment of inertia [kgm <sup>2</sup> /m]	1,20 x 10 <sup>-5</sup>		3,25 x 10 <sup>-5</sup>	
Max. velocity <sup>1)</sup> [m/s]	0,25		2	
Max. acceleration [m/s <sup>2</sup> ]	20		20	
No-load torque [Nm]	0,30		1,0	
Maximum travel (standard) [mm]	1245		5370	
Length of standard/long carriage [mm]	160 / 240		145 / 265	
Repeat accuracy [mm]	±0,03 (BSD)		±0,03 (KGT)	
Operating temperature [°C] (continuous operation)	0 ... 80		0 ... 80	
Geometrical moment of inertia I <sub>y</sub> [mm <sup>4</sup> ]	223339		446420	
Geometrical moment of inertia I <sub>z</sub> [mm <sup>4</sup> ]	1195788		2505144	
Weight (without travel) [kg]	3,25		11,0	
Weight (per 100 mm travel) [kg]	0,47		0,9	
Weight of standard carriage [kg]	1,30		2,3	
Weight of long carriage [kg]	1,85		3,25	
Noise emission max. [dB A] <sup>4)</sup>	75		75	

<sup>1)</sup> *Dependent on spindle pitch at max. speed*

<sup>2)</sup> *Ball Screw Drive*

<sup>3)</sup> *Trapezoidal Screw Drive*

<sup>4)</sup> *The figure will vary based on assembly with other system components*

Linear unit model Delta	Sizes			
	145-C	200	240	240-C
	SSS	SSS	SSS	SSS
Drive element	BSD <sup>2)</sup>	BSD <sup>2)</sup>	BSD <sup>2)</sup>	BSD <sup>2)</sup>
max. speed [rpm]	3000	3000	3000	3000
Spindle diameter [mm]	20	32	32	32
Spindle pitch [mm]	5 10 20 50	5 10 20 40	5 10 20 40	5 10 20 40
Moment of inertia [kgm <sup>2</sup> /m]	8,50 x 10 <sup>-5</sup>	6,45 x 10 <sup>-4</sup>	6,45 x 10 <sup>-4</sup>	6,45 x 10 <sup>-4</sup>
Max. velocity <sup>1)</sup> [m/s]	2,5	2	2	2
Max. acceleration [m/s <sup>2</sup> ]	20	20	20	20
No-load torque [Nm]	1,0	2,8	2,8	2,8
Maximum travel (standard) [mm]	5275	3620	2600	5400
Length of standard/long carriage [mm]	180 / 300	250 / 400	280 / 400	280 / 400
Repeat accuracy [mm]	±0,03 (BSD)	±0,03 (BSD)	±0,03 (BSD)	±0,03 (BSD)
Operating temperature [°C] (continuous operation)	0 ... 80	0 ... 80	0 ... 80	0 ... 80
Geometrical moment of inertia I <sub>y</sub> [mm <sup>4</sup> ]	1251254	3889990	6369119	4944409
Geometrical moment of inertia I <sub>z</sub> [mm <sup>4</sup> ]	7737207	28139811	59788355	38449888
Weight (without travel) [kg]	10,8	22	26	18,8
Weight (per 100 mm travel) [kg]	1,5	2,6	3,4	3,3
Weight of standard carriage [kg]	4,9	8,4	10,2	10,2
Weight of long carriage [kg]	6,5	11	14,6	14,6
Noise emission max. [dB A] <sup>4)</sup>	75	75	75	75

<sup>1)</sup> Dependent on spindle pitch at max. speed

<sup>2)</sup> Ball Screw Drive

<sup>3)</sup> Trapezoidal Screw Drive

<sup>4)</sup> The figure will vary based on assembly with other system components

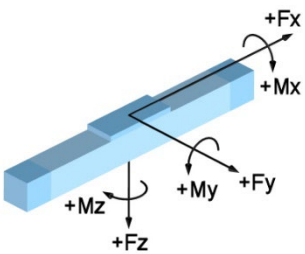

### Forces and moments - Delta linear unit with spindle drive

Type designation	Dynamic forces [N]				Dynamic moments [Nm]			
	F <sub>x</sub>	F <sub>y</sub>	F <sub>z</sub>	-F <sub>z</sub>	M <sub>x</sub>	M <sub>y</sub>	M <sub>z</sub>	M <sub>no-load</sub>
Delta 90-SRS	1000	500	1000	1000	60	80 (110)	80 (110)	0.3
Delta 110-C-SSS	2000	1200	3000	1500	500	550 (1000)	550 (1000)	1.0
Delta 145-SSS Delta 145-C-SSS	6000 4000	2500	5000	3000	800	1000 (1600)	1000 (1600)	1.1 1.0
Delta 200-SSS	10000	5000	8000	5000	3500	4300 (6000)	3200 (4500)	2.8
Delta 240-SSS	12000	6000	12000	8000	4500	6000 (8500)	4500 (6400)	2.8
Delta 240-C-SSS	12000	6000	12000	8000	4500	6000 (8500)	4500 (6400)	2.8

Figures in ( ) relate to the long carriage.

M<sub>no-load</sub> = No-load torque ±30 %

The forces and moments quoted are maximum values for the single load. In the event of combined loading or simultaneous occurrence of multiple moments or forces, the individual values must be reduced. In case of doubt consult Technical Support.

### Dynamic load ratings of rail guides - linear unit Delta SSS

(THK and Rex = Rexroth)

Model	Size	Number of rails	Number of carriages	Load rating per carriage C <sub>dyn</sub> [N] THK / Rex	Pre-tension F <sub>v</sub> THK / Rex	Guide spacing in direction x (lx1) [mm]	Guide spacing in direction y (ly) [mm]
Delta 110-C	15	2	4	11271 / 9860	564 / 620	75 (195)	66
Delta 145-C	20	2	4	17700 / 23400	885 / 1500	87 (207)	87
Delta 200	25	2	4	25160 / 28600	1258 / 1820	144 (294)	126
Delta 240 Delta 240-C	25	2	4	25160 / 28600	1258 / 1820	159 (279)	150

Figures in ( ) relate to the long carriage

The load rating and pre-tension figures relate to the standard linear guidance system with recirculating linear ball bearings

**Dynamic load ratings of ball screw drives - Delta linear unit**

Model and size	Nominal Ø in [mm]	Pitch in [mm]	C <sub>dyn</sub> [N]
Delta 90	12	5	3800
		10	4300
Delta 110-C	16	5	12800
		10	14300
		20	8100
		40	8500
Delta 145-C	20	5	14600
		10	13500
		20	11500
		50	12300
Delta 200	32	5	26200
		10	33100
		20	30200
		40	15200
Delta 240 Delta 240-C	32	5	26200
		10	33100
		20	30200
		40	15200

*Dynamic load rating of ball screw nut to DIN 69051, 1989*

**Static and dynamic load ratings of roller guides - linear unit Delta SRS**

Model	Size (∅) [mm]	Number of load-bearing rollers for Fz	Number of load-bearing rollers for Fy	Load rating per roller C <sub>stat</sub> [N]	Load rating per roller C <sub>dyn</sub> [N]	Guide spacing* in direction x [mm]		Guide spacing in direction y [mm]
						lx1	lx2	ly
Delta 90	20	4	2	600	1.500	100 (180)	100 (180)	54.5

The pre-tension per roller is approximately 5%

Tightening torques [Nm] for fixing screws							
Fixing screws	M4	M5	M6	M8	M10	M12	The figures given are intended as guides. For shorter insertion depths, the figures must be adjusted accordingly.
DIN912/ISO4762-8.8	2,7	5,4	9,0	22,0	43,0	74,0	
DIN912/ISO4762-10.9	3,0	5,7	9,0	22,0	43,0	74,0	
DIN912/ISO4762-12.9	3,0	5,7	9,0	22,0	43,0	74,0	

Tightening torques [Nm] for clutch with clamping hub					
Size	14	19	24	28	38
Clutch diameter [mm]	30	40	55	65	80
Screw size	M3	M6	M6	M8	M8
Tightening torque [Nm]	1.34	10.50	10.50	25.00	25.00

Tightening torques [Nm] for clutch with clamping ring hub					
Size	14	19	24	28	38
Clutch diameter [mm]	30	40	55	65	80
Screw size	M3	M4	M5	M5	M6
Tightening torque [Nm]	1.34	2.90	6.00	6.00	10.00

## 4 Product description

**Linear unit with spindle drive and roller guideway or rail guidance**

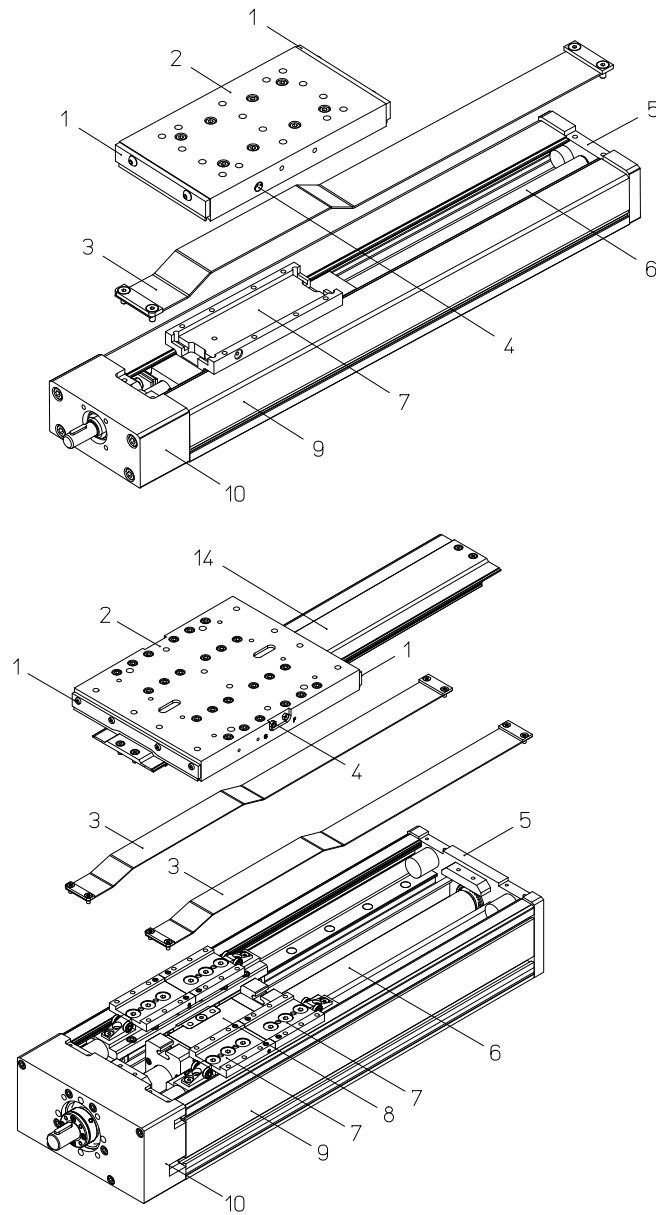

Key	1	Stripper brush	7	Driver
	2	Carriage	8	Nut driver
	3	Cover band	9	Base profile
	4	Lubricating nipple	10	Drive bearing
	5	Movable bearing	14	<u>Centre bar</u>
	6	Spindle		

Figure 1: Component assemblies of Delta 90 (above) and Delta 200 linear unit with spindle drive

**Guide elements  
 roller guideway and  
 rail guidance**

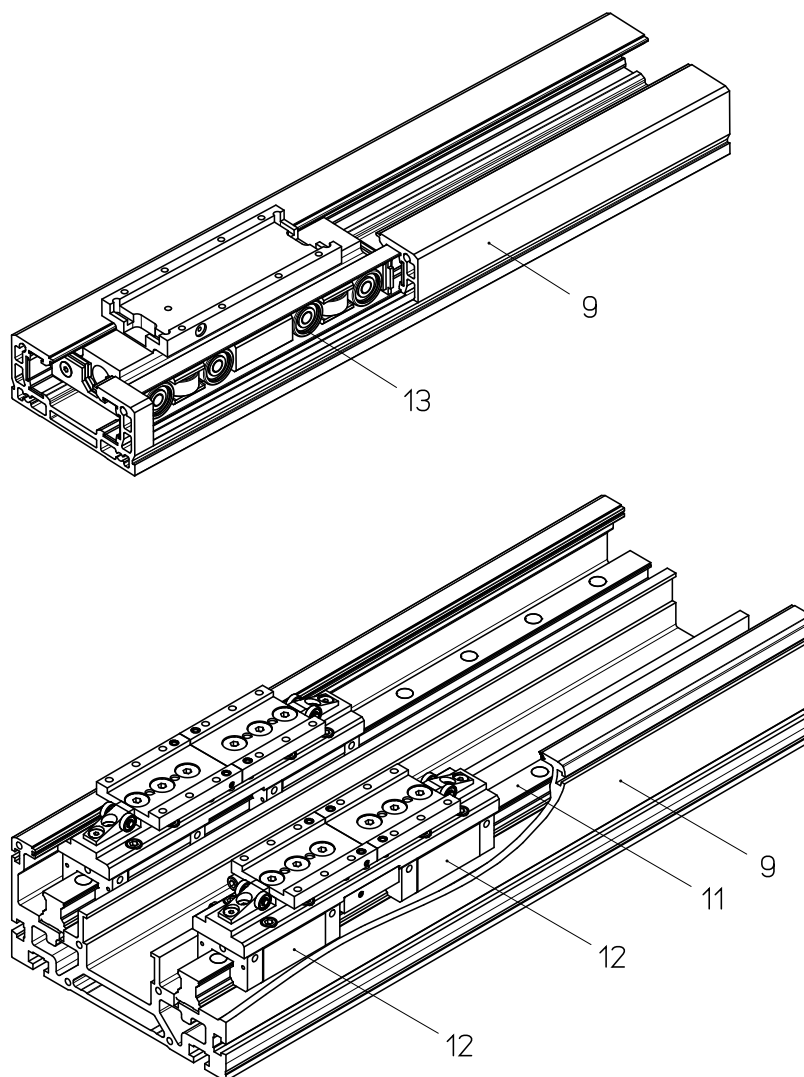

Key	9	Base profile	13	Roller guideway
	11	Guide rail		
	12	Recirculating ball bearing		

Figure 2: Rail guidance of Delta 90 (above) and Delta 200 linear unit

A mechanical linear unit converts rotational motion into linear motion and is used to move loads quickly, safely and precisely from one position to another. It consists of an aluminium base profile, a moving carriage supported by a guide element (recirculating ball bearing guidance system) and a drive element (screw or timing belt drive).

Depending on its design, the carriage is able to absorb forces and moments in all directions, and is positively connected to the guidance and drive elements by way of the so-called drivers.

The base profile is self-supporting up to a certain length, and is equipped with grooves for mounting.

As an option, the linear unit can be equipped with accessories such as screw supports, inductive or mechanical limit switches and other fittings (see section **6.3**).

The effective range can be flexibly configured. Multiple linear units of the Alpha, Beta or Delta type can be arranged two-dimensionally (2 axes) or three-dimensionally (3 axes).

Driven linear units can be connected to non-driven units of the same type by a plate, to be able to take large-area loads for example.

## 5 Transportation and storage

The mechanical linear unit is a precision item. Its mechanism may be damaged by heavy jolting, resulting in impairment of its functions.

### CAUTION



---

Risk of damage by heavy jolting or deformation!

Transport the assembled linear unit only with the transportation safety fixtures attached.

---

To prevent damage during transportation and storage, protect the linear unit against shaking and sliding as follows:

- Stow it in a box of sufficient size.
- Use packing.

Section 3 lists the unit weights.

Protect the unit against:

- dirt;
- corrosion;
- water;
- and aggressive atmospheres.

## 6 Installation and adjustment

The linear unit can be attached by the following methods:

- On mounting rails
- By screws inserted into the sliding blocks
- By screws inserted into the factory-fitted tapped hole rails

☛ Install the linear unit on a flat surface. Unit parallelism  $<0.2 \text{ mm}/1000 \text{ mm}$ .

☛ Mounting by the rails with tapped holes in them is the preferable solution:  
for highly dynamic applications;  
where the linear unit has only two attachment points.

### 6.1 Installing the linear unit by mounting rails

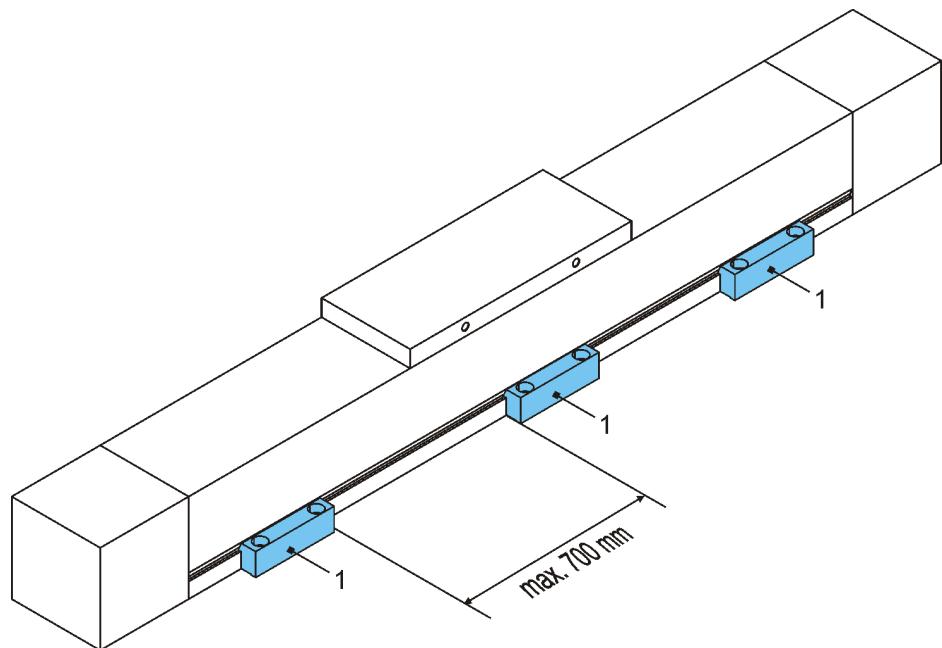

Figure 3: Mounting rails (1)

☛ The recommended maximum spacing between the mounting rails is 700 mm.

#### Procedure

1. Attach the mounting rails (1) loosely in position (Figure 3).
2. Align the linear unit axially.
3. Tighten the mounting rails (1)  
(for tightening torques see section 3).

## 6.2 Screwing the linear unit into place from below (not Delta 90)

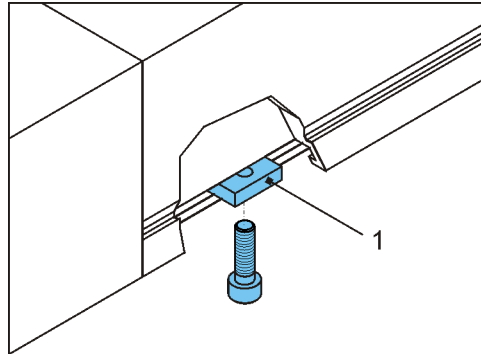

Figure 4: Sliding blocks (1) in the groove on the underside of the base profile

Attach the linear unit by the fixing screws from below using the sliding blocks or the tapped hole rails in the aluminium base profile (Figure 4).

### Procedure

1. Align the linear unit.
2. Align the sliding blocks (1)/tapped hole rails.
3. Tighten the linear unit  
(for tightening torques see section 3).

## 6.3 Setting maximum travel

DANGER



Serious injury may result if the transport carriers topple over. If the carriage moves to its full extent beyond the safety zone, the transport carrier mounted on it may break away or topple over. The linear unit may be destroyed.

Keep to the specified safety zone when setting up the unit, and set the limit switches accordingly.

Electrical switches may only be connected by qualified electricians.

☛ To stop the carriage promptly in the event of an emergency stop, allow for adequate braking distance.

### 6.3.1 Setting the positions of the inductive limit switches

The function of inductive proximity switches is to shut down the electric drive before the mechanical end position is reached.

The necessary braking distance ( $\Delta B$ ) depends on the velocity and deceleration of the carriage. The braking distance must be between the switching point of the proximity switch and the actual mechanical end position.

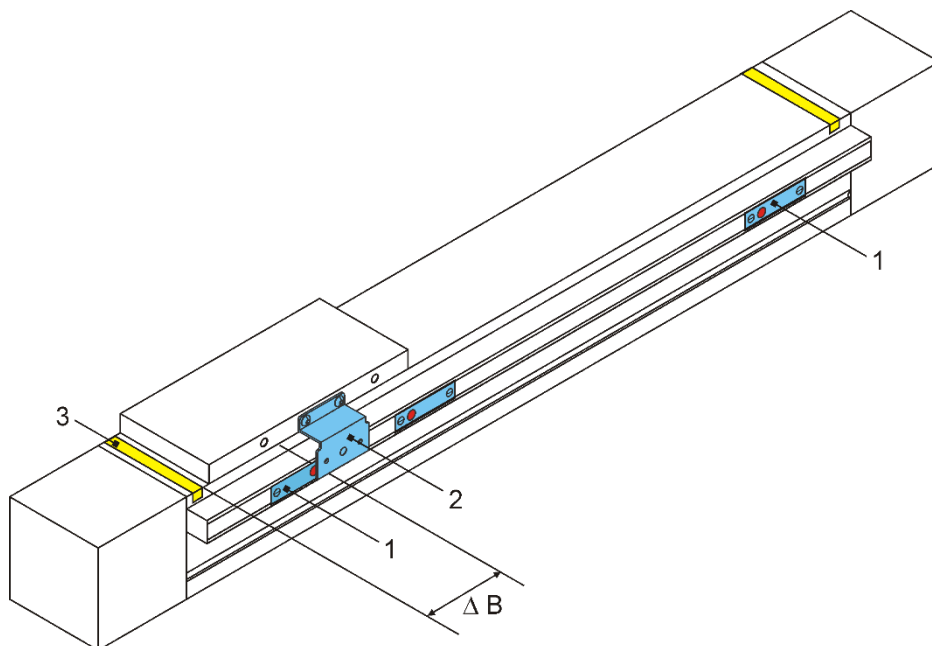

Key	1	Inductive limit switch
	2	Switching cam
	3	Band marking safety zone

Figure 5: Inductive limit switches

CAUTION



The limit switches must switch so that the carriage comes to a stop immediately before the safety zone. The safety zone is factory-marked on the unit by a band (3).

#### Procedure

1. Connect the power to the limit switches.
2. Slacken the limit switch fixing screws.
3. Run the carriage as far as the braking position.
4. Move the limit switch (NC contact) under the switching cam until it trips and the LED on the sensor goes out.
5. Move the carriage away.
6. Tighten the limit switch.
7. Check the correct position of the limit switch: Move the carriage manually and observe the switching operation.
8. Fit the limit switch array covering.

### 6.3.2 Setting the positions of the mechanical limit switches

Mechanical safety limit switches (NC contacts) must be used if a hazard is posed to personnel as soon as the electric drive fails to shut down.

The drive may only be started up when all limit switches are connected and correctly set!

A combination with inductive proximity switches is possible.

External shock-absorbers must be fitted to protect against mechanical destruction.

The necessary braking distance ( $\Delta B$ ) depends on the velocity and deceleration of the carriage. The braking distance must be between the switching point of the limit switch and the actual mechanical end position (Figure 6).

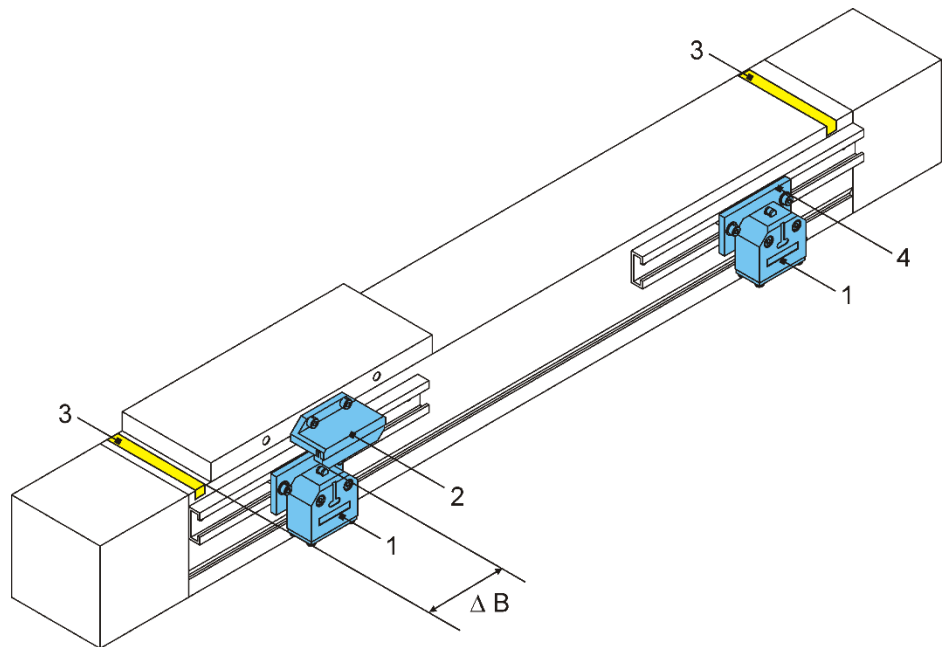

Key	1	Mechanical limit switches
	2	Switching cam
	3	Band marking safety zone
	4	Bracket
	B	Braking distance

Figure 6: Mechanical limit switches

**CAUTION**



The limit switches must switch so that the carriage comes to a stop immediately before the safety zone. The safety zone is factory-marked on the unit by a band (3).

**Procedure**

1. Connect the power to the limit switches.
2. Slacken the bracket fixing screw (Figure 6).
3. Run the carriage as far as the safety zone.
4. Move the limit switch until it trips.
5. Tighten the bracket fixing screw.
6. Check the correct position of the limit switch: Move the carriage manually and observe the switching operation.  
If the braking distance is too short, repeat the set-up.

## 6.4 Mounting a drive unit

Make sure the direction of rotation of the external drive unit takes into account the direction of the spindle or timing belt so that the limit switches work correctly.

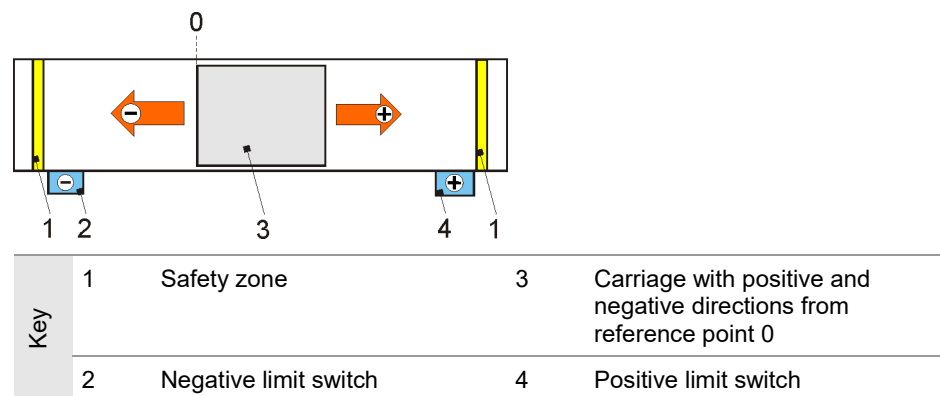

*Figure 7: Example of travel direction and limit switch configuration*

### 6.4.1 Mounting a motor

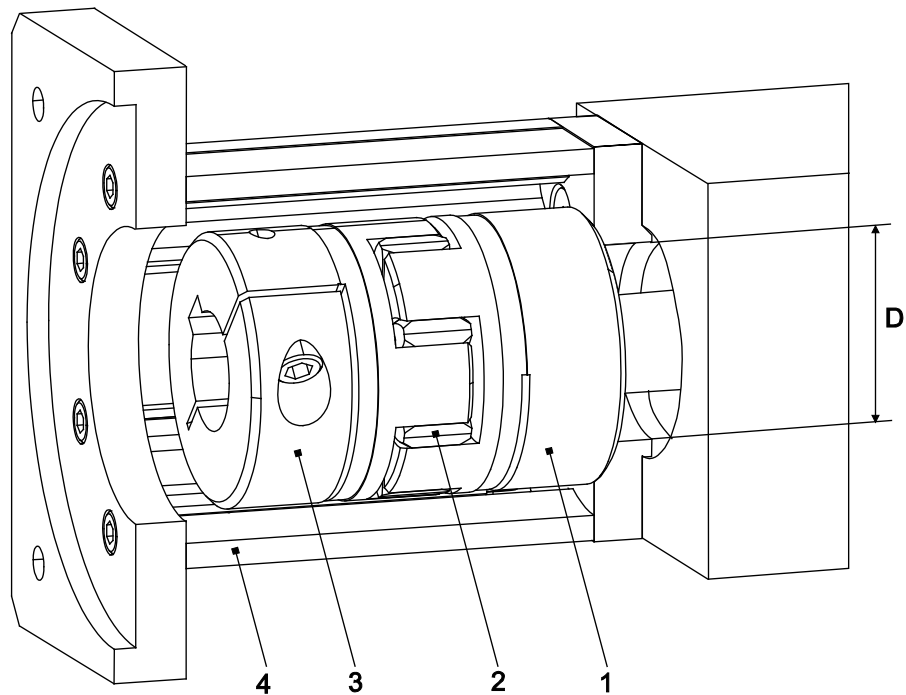

Key	1	Clutch half 1	4	Motor housing
	2	Clutch ring	D	Diameter on motor housing
	3	Clutch half 2		

Figure 8 Motor housing with motor clutch on drive pin

#### Procedure

1. Place the motor and the clutch components in mounting position adjacent to the linear unit.
2. Check the direction of rotation of the motor. It must take into account the safety limit switches (Figure 7). Alter the direction of the motor as necessary.
3. If the clutch diameter is less than the measure D on the motor housing (4), first mount clutch half 1 (1) (drill hole flush with drive shaft) and then the motor housing (4) (Figure 8).

If the clutch diameter is greater than the measure D on the motor housing (4), first mount the motor housing (4) and then clutch half 1 (1) (drill hole flush with drive shaft). Tighten the clutch clamping screw through the mounting hole on the motor housing (4).

4. Slot the clutch ring (2) onto the clutch.
5. Mount clutch half 2 (3) on the motor pin.
6. Mount the motor on the motor housing.

### Tightening torque [Nm] of clamping screws

Screw	SW	Torque
M6	5	14
M8	6	35
M10	8	65
M12	10	74

## 7 Start-up

WARNING



Risk of injury to personnel or damage to other components due to the high-speed linear motion of the transport carrier by the load being thrown off.

Only authorised technical personnel may operate the linear unit.

WARNING



Risk of crushing if the transport carrier is moved in the wrong direction. If the directions of rotation of the drive (motor or gearbox) and of the carriage drive (spindle or timing belt) do not match, the mounted transport carrier may move in the wrong direction.

Only qualified electricians may carry out electrical installation and check rotation.

### Checks before start-up

Before starting the unit, check the following:

- Make sure the retaining fixtures conform to the mass and acceleration data provided by the manufacturers.
- Make sure the machine or line into which the linear unit is installed conforms to the EU Machinery Directive, the harmonised European standards or applicable national standards.
- Make sure the linear unit is correctly installed.
- Make sure the inductive and/or mechanical limit switches are correctly connected and working properly.
- Make sure the direction of rotation of the motor shaft and - where appropriate - of the interposed gearbox - matches that of the spindle or timing belt.

If the checks reveal any defects, prohibit start-up of the unit.

### Trial run

To prevent accidents, collisions and possible errors in the programming, move the linear unit along the stroke several times at such a low speed that it can be stopped in good time in case of an emergency.

The line may be started up once it has been established that there is no risk of collision when the maximum travel is overrun.

## 8 Operation

### CAUTION



Risk of damage from harmful environmental influences!  
Operate the linear unit only under the ambient conditions approved by the manufacturers.

#### Ambient conditions

The linear unit may only be operated within the permitted temperature range of 0 - 80 °C.

Operating the unit in damp, abrasive conditions may result in foreign objects entering components in the linear unit. To prevent this, as part of the integration of the linear unit into the entire plant, measures may need to be taken to prevent foreign bodies from penetrating, e.g. using folding plates, baffle plates, sealing air.

#### Duty of inspection

The proper functioning of the linear unit must be checked periodically during operation.

The responsible personnel must check the linear unit and the line for external signs of damage and defects at least once every shift.

If changes occur which are detrimental to safety, shut down the line immediately.

#### Emergency stop

The maximum permissible load values must not be exceeded even in an emergency stop situation.

As a rule, the category 1 emergency stop strategy (targeted braking to standstill, then de-energise) is chosen for automation equipment with moving masses. A simple emergency stop strategy is not usually effective, as the masses are still moving and can cause damage.

#### End position damping

The end stops and stop buffers installed in our linear modules protect the unit at low speed (commissioning). They are definitely not intended to completely protect the unit against damage at high speed and/or with a large mass.

## 9 Shutdown

### WARNING



Risk of injury to personnel or damage to other components from falling components.  
Only authorised technical personnel may operate the linear unit.

1. Cut the power to the machine/line.
2. Dismantle the drive from the linear unit.
3. Detach the linear unit from the machine/line.

## 10 Maintenance

- All installed ball bearings are sealed and maintenance-free.
- Remove excessive dust and dirt from the cover band and other components of the linear unit on a regular basis.
- Relubricate the thread drives of the linear axes on a regular basis.

### 10.1 Lubrication

#### Influencing factors

The following factors are key to determining the exact lubrication intervals required:

- Loading
- Velocity
- Motion
- Operating temperature
- Degree of dirtying

#### Short lubrication intervals

Short lubrication intervals are required for:

- operation under the influence of dust and dampness
- a heavy load
- high speed (up to  $V_{max}$ )

#### Short strokes (Short stroke design)

Short stroke refers to a stroke with a value equal to or lower than that specified in the table. To achieve the best possible lubrication, relubrication should be carried out from both sides with guiding carriage short strokes and thus requires a special attachment. (Design feasibility must be checked.)

A lubrication stroke should also be carried out at least once per shift (8 hours) where possible.

Größe	12	15	20	25	25L	30	30L	35	35L
THK	40	95	120	140	175	160	210	185	250
Bosch-Rex.	40	80	100	115	160	135	180	155	210
Lubrication stroke	70	130	160	180	220	210	260	240	300

In addition, it must be ensured that the stroke is at least (2x) the length of the ball screw nut. If this is not the case, consultation is mandatory.

#### Initial lubrication

☛ Carry out an initial lubrication after starting up the unit for the first time. A basic lubrication was applied at the factory.

Refer to the lubrication regulations on the following pages.

**Lubrication points on linear units**  
 (not Delta 90 as lubricated for life)

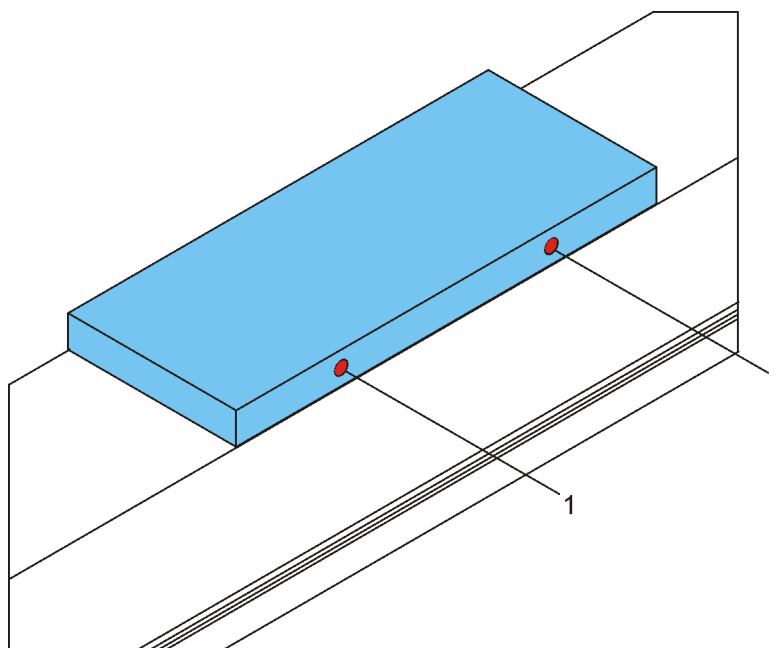

Figure 9: Possible lubrication points (1) on the carriage

The categories, quantity and positions of lubrication point depend on the model of linear unit. The categories of lubrication point are identified by the markings S, F on the unit. There is a separate lubrication schedule for each lubrication point category.

Lubrication point category	Lubrication for...	Lubricant
S	Spindle	Grease
F	Guide elements	Grease

**Lubrication method**

Lubrication should, as far as possible, take place while the unit is running, so that the grease is distributed evenly and no pressure is built up.

**Schedule for lubrication point S (for ball screw drive)**

BSD* type	Lubrication intervals at roll-overs	Grease quantity [cm <sup>3</sup> ] per ball screw nut	Grease type
1205	25.000.000**	0.60	Greases to DIN 51825-KP2N-20, e.g. Klüberplex BE 31-102  ☛ If other greases are used, pay attention to manufacturers' specifications!  ☛ Greases containing solid lubricant (e.g. graphite, MoS <sub>2</sub> ) must not be used!
1210		0.60	
1605		1.70	
1610		1.80	
1620		1.90	
2005		2.00	
2020		2.30	
2050		4.50	
2505		2.60	
2510		3.40	
2525		3.10	
2550		4.80	
3205		4.20	
3210		13.10	
3220		8.40	
3232		5.30	
3240		3.00	
4005		15.000.000**	
4010	15.40		
4020	10.20		
4040	9.50		

\*BSD = Ball Screw Drive  
 \*\* Or at least 2x per year. The lubrication interval depends on the ambient temperatures and on the loading (see figure 9). Relubrication "in motion"!

**Schedule for lubrication point F (for linear guide)**

Carriage size	Lubrication interval	Grease quantity [cm <sup>3</sup> ] per carriage	Grease type
15 with ball chain	approx. 5,000 km*	approx. 0.4	Greases to DIN 51825-KPE1R-20, e.g. Klüberplex BE 31-102 ⚠ If other greases are used, pay attention to manufacturers' specifications! ⚠ Greases containing solid lubricant (e.g. graphite, MoS <sub>2</sub> ) must not be used!
20 with ball chain		approx. 0.6	
25(L) with ball chain		approx. 1.2	
30 with ball chain		approx. 1.5	
35 with ball chain		approx. 1.7	
15 without ball chain	approx. 2,000 km*	approx. 0.8	
20 without ball chain		approx. 1.4	
25(L) without ball chain		approx. 2.8	
30 without ball chain		approx. 4.4	
35 without ball chain		approx. 4.4	

\* Or at least 2 x per year. The lubrication interval depends on the ambient temperatures and on the loading (see figure 9). Relubrication "in motion"!

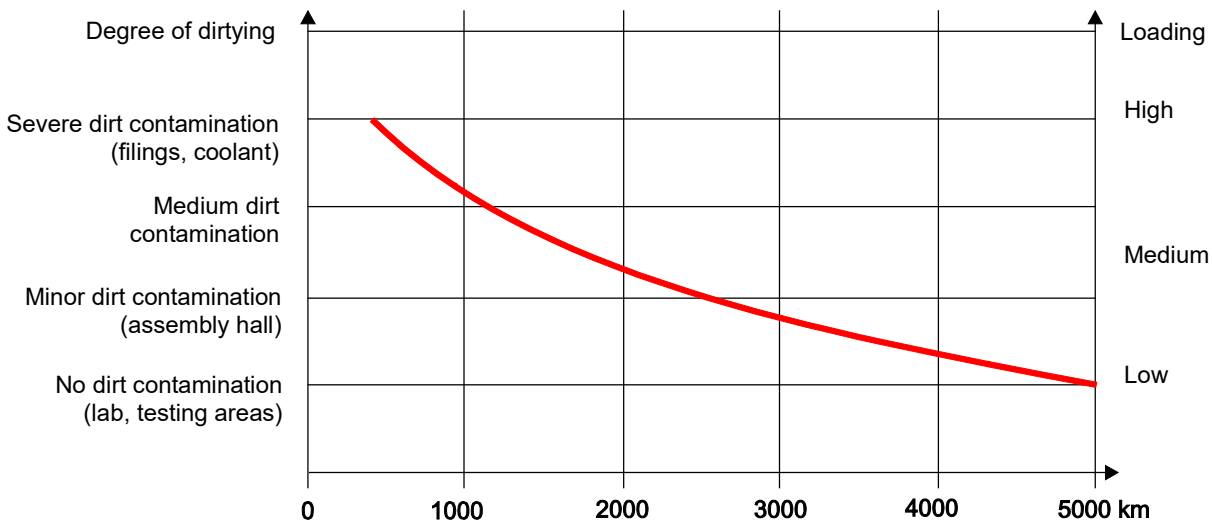





Figure 10: Relubrication intervals for the linear guidance system with recirculating linear ball bearings

## 10.2 Replacing cover bands

 To preserve the optimum running of the linear unit and prevent it from being damaged during operation, take care that no foreign bodies penetrate the base profile or other linear unit components during installation and assembly.

 Do not damage the standard parts (screws, pins, etc.) or the dismantled components; they will be refitted.

 If cover bands are worn, also replace the band guide elements. If cover bands are damaged, check the band guide elements for wear and replace them only as necessary.

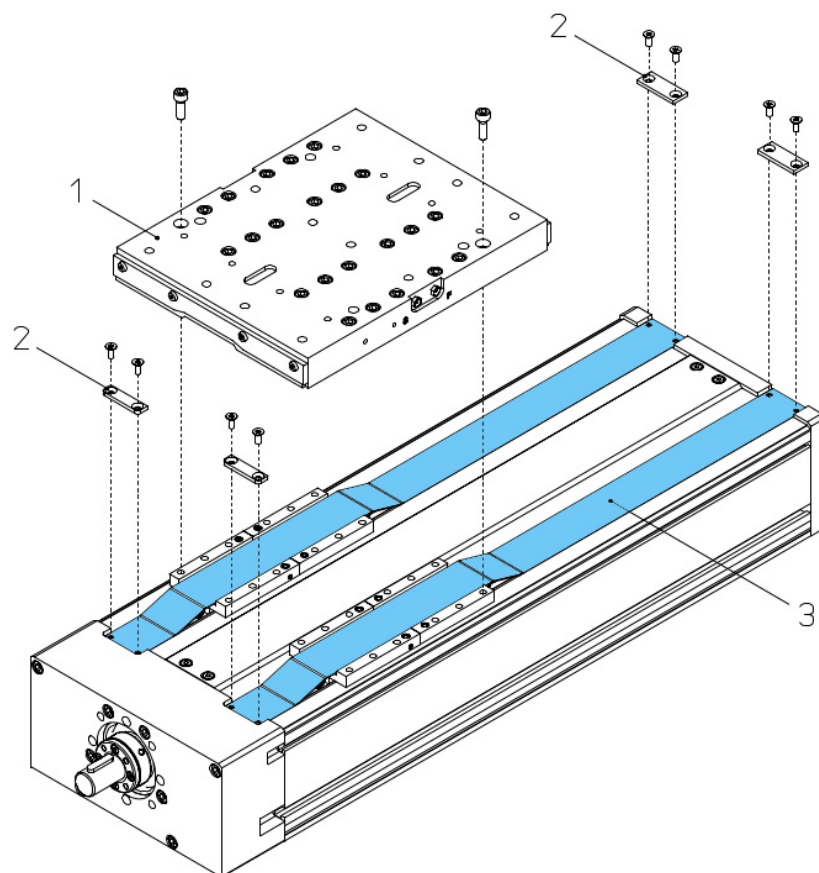

Key	1	Carriage
	2	Clamp fittings
	3	Cover band

Figure 11: Cover bands based on the example of the Delta 200 linear unit

## Procedure

1. Move the carriage into the middle and remove it.  
Caution! Do not rotate the carriage. It must be refitted in the same position!

☛ Do not lose the O-rings fitted on the lubricating apertures on the underside of the carriage (not Delta 90).

2. Detach the clamp fittings from the ends of the cover band and remove the cover band.

3. Check the band guide elements such as the press rollers (a), lifting rollers (b) and locating pins for wear.

- If the cover band is worn, be sure also to replace the band guide elements. Worn guide elements will damage the new cover band.
- If the cover band is damaged, replace the band guide elements only if they are damaged. Do not interchange the press rollers (a), as they are different.

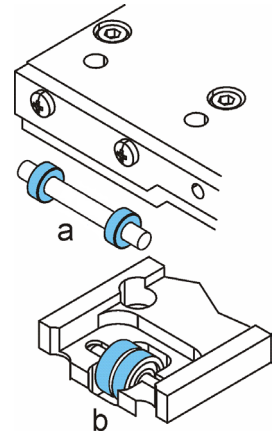

4. Insert the new cover band with its broader side (with the chamfered cutting edge) facing downwards and fix it at one end by the clamp fitting.
5. Carefully press the cover band into its guideway along its entire length until it audibly snaps into place. It must not stick out at any point, otherwise it will be damaged.
6. Stretch the cover band and fix it by the clamp fitting at the other end.
7. If the band guide elements are worn, mount the new elements on the underside of the carriage.
8. Make sure the O-rings are fitted on the lubricating apertures on the underside of the carriage and refit the carriage in the correct position.
9. To check that the carriage is correctly installed, run it slowly from one end of the linear unit to the other, ensuring the cover band is held all the time in its guideway.

### 10.3 Your added value in service: Repair and Retrofit

In addition to installation and maintenance, we also offer professional repair and retrofit services for our products. You benefit from our expertise, fast fault diagnosis, and expert repairs – helping to extend the service life of your products and modernize existing systems.

For further information regarding repairs or retrofit solutions, please contact our customer service at [service.greifsysteme@de.schunk.com](mailto:service.greifsysteme@de.schunk.com).

We will be happy to advise you.