

Original Assembly and Maintenance Instructions

Portal-Linear Unit

HSB-gamma

Types

Gamma 90-AZSH/AZSS
Gamma 120-AZSH/AZSS
Gamma 160-AZSH/AZSS
Gamma 220-AZSH/AZSS
Gamma 280-AZSS
Gamma 300 AZSS
Gamma 400-AZSS

HSB Automation GmbH
In Laisen 74
72766 Reutlingen
Germany
Tel. +49 7121 14498-0
info@hsb-automation.de
www.hsb-automation.de

Distributor:
SCHUNK GmbH & Co. KG
Spann- und Greiftechnik
Bahnhofstr. 106 - 134
74348 Lauffen/Neckar
Germany
Tel. +49 7133-103-0
Fax +49 7133-103-2399
info@de.schunk.com
www.schunk.com

Table of Contents

1	Safety	2
1.1	Symbols used	2
1.2	Intended use.....	2
1.3	General safety	3
1.4	Use in potentially explosive areas.....	3
1.5	Technical condition of the linear unit.....	3
1.6	Changes to the linear unit.....	3
1.7	Requirements of personnel.....	4
1.8	Responsibilities of the operator.....	4
2	Warranty	4
3	Technical Data - Standard design	5
4	Product description	9
5	Transport and Storage	10
6	Assembly and Alignment	11
6.1	Screw linear unit into place from underneath (applies not to size 400).....	11
6.2	Set maximum stroke.....	12
6.3	Installing the drive.....	12
6.3.1	Installing the motor.....	12
7	Commissioning	13
8	Operation	14
9	Decommissioning	15
10	Maintenance	15
10.1	Lubrication.....	16
10.2	Your added value in service: Repair and Retrofit.....	20

1 Safety

These Operating Instructions are an important part of the machine and must always be kept within reach.

They must be passed on together with the machine to any third party.

It is important that you contact the manufacturer should there be any part of these instructions that you do not clearly understand.

1.1 Symbols used

In these Operating Instructions, the following warning symbols and other symbols are used:

DANGER



Indicates immediate danger.

Failure to comply with this instruction may result in death or serious injury.

WARNING



Indicates a danger carrying a medium to high risk.

Failure to comply with this instruction may result in death or serious injury.

CAUTION



Indicates a danger carrying low risk.

Failure to comply with this instruction may result in slight injury or material damage.

 Note

Includes tips for the operation and optimal use of the machine.

1.2 Intended use

The linear unit is solely intended for the purpose of manipulating, positioning, transporting, palletising, loading, unloading, clamping, synchronising, tensioning, testing, measuring, handling and pressing of component parts or tools.

Please take note of the principal fields of application of the linear unit (see Section 4 and Section 3).

In order to guarantee compliance with the law concerning the electromagnetic compatibility of devices (EMC directive), the linear unit may be used for industrial applications only (in accordance with EN 61000-6-1).

Any other use of the machine will be deemed to be not in accordance with its intended use. The manufacturer accepts no liability for any damages resulting therefrom. The risk is borne solely by the user.

1.3 General safety

Date of commissioning	<p>The linear unit may be operated only when the machine or installation into which it has been built is found to comply with the following guidelines, laws, regulations and standards:</p> <ul style="list-style-type: none"> • EC/EU directives, • standards regarding the electromagnetic compatibility of devices or machinery,
Safe operation	<p>For the safe operation of the drive, please take into account the following documentation:</p> <ul style="list-style-type: none"> • these Operating Instructions for the linear unit, in particular the Technical Specifications • the Operating Instructions for the entire installation
Decommissioning	<p>Dispose of the product in accordance with the applicable national requirements. Observe the safety data sheets.</p>

1.4 Use in potentially explosive areas



Linear units are not designed for use in potentially explosive atmospheres.

1.5 Technical condition of the linear unit

State of the art	<p>The unit conforms to the current state of the art and applicable rules and regulations. The device complies with the EC Machinery Directive and the relevant Harmonised Standards (European standards). Furthermore, the EC Declaration of Incorporation applies.</p>
-------------------------	--

1.6 Changes to the linear unit

Rebuilding and modifying	<p>There are to be no changes, either structural or safety-related, carried out on the linear unit without the prior written agreement of HRB. We accept no liability for any unauthorised changes carried out on the unit.</p> <p>The operator may only carry out the maintenance and repair work specified in these Operating Instructions. Any further work involving the replacement of wear or substitute parts may only be carried out following consultation with our service technicians and by the service technicians themselves or by HRB.</p> <p>Never disassemble or decommission any safety or protection devices.</p>
---------------------------------	--

Follow the assembly instructions supplied by the manufacturer when using special attachment parts!

1.7 Requirements of personnel

Any work involving live parts may only be carried out by trained electricians. This work involves, for example:

- the installation of safety limit switches,
- the attachment of a drive,
- checking the direction of the drive rotation.

1.8 Responsibilities of the operator

Preservation of labels The operator must ensure that any lettering, information signs or labels are fully legible (in particular the serial number) and always observed. Any damaged or illegible information signs and labels must be replaced.

Accident Prevention and Environmental Protection The applicable regulations for accident prevention and environmental protection must be observed.

Disposal Dispose of the product according to the relevant national regulations. Refer to the safety data sheets.

2 Warranty

The warranty conditions are specified in the sales documents (delivery and payment conditions). The warranty claim expires if:

- the unit has not been used in accordance with its intended use,
- these Operating Instructions have not been adhered to,
- the unit has been modified without prior authorisation from the manufacturer,
- screws sealed using locking paint have been opened.

The manufacturer is only liable if original spare parts have been used during any maintenance or repair work carried out on the unit.

3 Technical Data - Standard design

Gamma AZSH/AZSS Linear Unit	Unit sizes		
	90	120	160
Drive element	Rack and pinion		
	Module 2	Module 2	Module 2
Stroke per revolution [mm]	120	200	200
Speed max. [m/s]	3.2	5	5
Max. acceleration [m/s ²]	20	20	20
Idle torque [Nm] on drive pinion	2.50	4.80	5.80
Maximum stroke (standard) [mm]	7600	7470	7370
Length of standard sliding carriage [mm]	320	500	500
Repeat accuracy [mm]	±0.05	±0.05	±0.05
Operating temperature [°C] (Continuous operation)	0...80	0...80	0...80-
Geometrical moment of inertia I _y [mm ⁴]	1373211	4636416	9549307
Geometrical moment of inertia I _z [mm ⁴]	2297416	6696292	18710430
Weight (without stroke) [kg] ¹⁾	15.00	26.10	34.05
	14.85	25.85	33.25
Weight (per 100 mm stroke) [kg]	1.30	2.10	3.00
Weight of standard sliding carriage [kg] ¹⁾	4.35	8.45	14.70
	4.20	8.20	13.90
Max. noise emission [dB A] ²⁾	79	79	79

¹⁾ Top value applies to AZSH, bottom value is for AZSS

²⁾ The value changes if combined with other system parts.

Gamma AZSH/AZSS Linear Unit	Unit sizes				
	220		280	300	400
Drive element	Zahnstange				
	Module 2	Module 3	Module 4	Module 3	Module 4
Stroke per revolution [mm]	200		200	200	280
Speed max. [m/s]	4.5		4.5	4.0	4.0
Max. acceleration [m/s ²]	20		20	20	20
Idle torque [Nm] on drive pinion	7.20		8.60	10.00	12.00
Maximum stroke (standard) [mm]	11320		9220	14270	5860
Length of standard sliding carriage [mm]	550		600	600	600
Repeat accuracy [mm]	±0.05		±0.05	±0.05	±0.05
Operating temperature [°C] (Continuous operation)	0...80		0...80	0...80	0...80
Geometrical moment of inertia I _y [mm ⁴]	23604804		51584879	59687411	235174054
Geometrical moment of inertia I _z [mm ⁴]	60771950		145637924	111143309	364885173
Weight (without stroke) [kg] ¹⁾	50.80	53.90	-	-	-
	49.80	52.70	84.70	298	557
Weight (per 100 mm stroke) [kg]	4.60	4.80	6.95	11.90	18.00
Weight of standard sliding carriage [kg] ¹⁾	19.10	21.60	-	-	-
	18.10	20.40	50.00	92.00	182.30
Max. noise emission [dB A] ²⁾	79		79	79	79

¹⁾ Top value applies to AZSH, bottom value is for AZSS

²⁾ The value changes if combined with other system parts.

Type designation	Dynamic forces [N]				Dynamic moments [Nm]			
	F_x	F_y	F_z	$-F_z$	M_x	M_y	M_z	M_{idle}
Gamma 90-AZSH/AZSS	1300-1800	3000	3000	3000	600	1800	1800	2.50
Gamma 120-AZSH/AZSS	1500-2200	8000	8000	8000	1500	4000	4000	4.80
Gamma 160-AZSH/AZSS	1500-4000	12000	12000	12000	2500	7000	7000	5.80
Gamma 220-AZSH/AZSS	3000-7500	20000	20000	20000	4000	8000	8000	7.20
Gamma 280-AZSS	3000-7500	25000	25000	25000	8000	16000	16000	8.60
Gamma 300-AZSS	5000-7500	40000	40000	40000	13000	25000	25000	10.00
Gamma 400-AZSS	6700-9600	60000	60000	60000	25000	35000	35000	12.00

M_{idle} = Idle torque $\pm 30\%$ (Value given applies for gear ratio $i=6$)

The data given for forces and moments are the respective maximum values for the single load. The individual values must be reduced for a mixed load or the appearance of several moments or forces at the same time. If in doubt, please contact Technical Support.

Dynamic load ratings for the Gamma AZSH/AZSS linear unit

(THK and Rex = Rexroth)

Unit size	Size	No. of rails	No. of sliding carriages	Load rating per sliding carriage	Pretensioning	Guiding distance in direction x (lx1)	Guiding distance in direction y (ly)
				C_{dyn} [N]	F_v [N]	in direction x (lx1) [mm]	in direction y (ly) [mm]
				THK / Rex	THK / Rex		
Gamma 90-AZSH/AZSS	15	2	4	11271 / 9860	564 / 620	255	90
Gamma 120-AZSH/AZSS	20	2	4	17700 / 23400	885 / 1500	320	115
Gamma 160-AZSH/AZSS	25	2	4	25160 / 28600	1258 / 1820	402	151
Gamma 220-AZSH/AZSS	25L	2	4	29208 / 37300	1460 / 2430	440	196
Gamma 280-AZSS	35	2	4	49448 / 51800	2472 / 3350	480	253
Gamma 300-AZSS	35L	2	4	57861 / 66700	2893 / 4450	558 258	273
Gamma 400-AZSS	45L	2	4	79370 / 111000	3968 / 7230	720 270	368

The load rating and pretensioning values refer to the standard linear guide system

Tightening torques [Nm] for fixing screws							
Fixing screws	M4	M5	M6	M8	M10	M12	The figures given are intended as guides. For shorter insertion depths, the figures must be adjusted accordingly.
DIN912/ISO4762-8.8	2,7	5,4	9,0	22,0	43,0	74,0	
DIN912/ISO4762-10.9	3,0	5,7	9,0	22,0	43,0	74,0	
DIN912/ISO4762-12.9	3,0	5,7	9,0	22,0	43,0	74,0	

4 Product description

Guide elements Rail guide

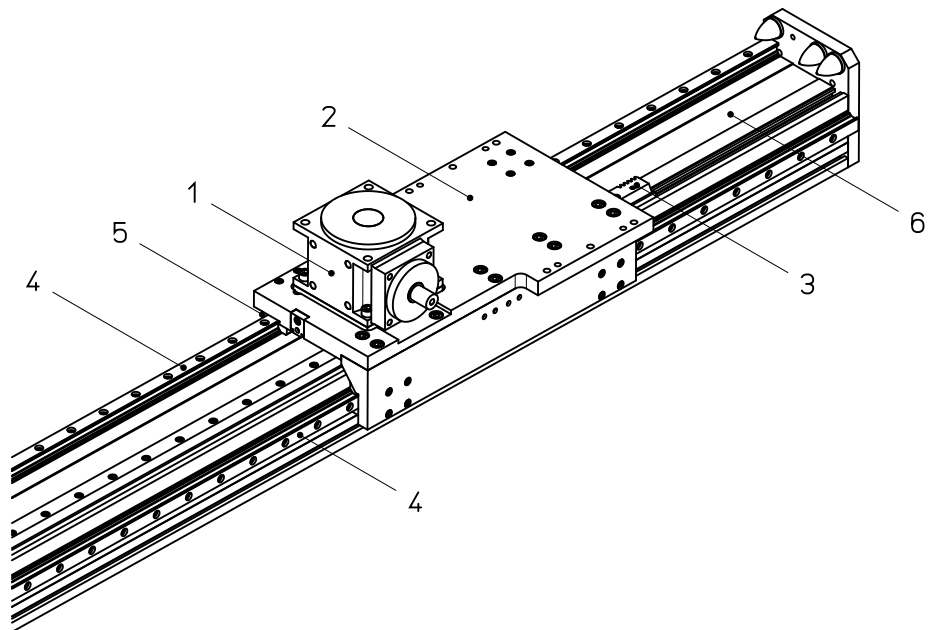

Legend	1	Drive gear	4	Guide rail
	2	Carriages	5	Guide carriage
	3	Rack and pinion	6	Basic profile

Image 1: Guide elements for the Gamma AZSS linear unit

A mechanical linear unit changes rotary motion into linear motion and thus facilitates the fast, safe and accurate movement of loads from one position to another. It consists of a basic aluminium profile, a moveable sliding carriage which is supported by a guide element (linear guide system) and a drive element (rack-and-pinion drive).

Depending on the design, the sliding carriage can absorb forces and moments in all directions and is non-positively connected to the guide and drive element via the slide plate.

The basic profile is self-supporting up to a certain length and fitted with grooves to keep it in place.

The operating area can be flexibly arranged. Several of the Gamma linear units can be arranged to cover a large area (2 axes) or according to space (3 axes).

A plate can be used to connect driven linear units to non-driven linear units of the same type in order to, for example, be able to take on large loads.

5 Transport and Storage

The mechanical linear unit is a precision instrument. Any heavy impact to this instrument may damage the mechanics and impair its functionality.

CAUTION



Risk of damage by heavy impact or bending!

Only transport an assembled linear unit using transport locks.

In order to avoid any damage to the linear unit when storing or transporting it, the following measures must be taken in order to protect it from jolting or slipping:

- Transport the unit in a sufficiently large container
- Use cushioned packaging

In section 3, the weight values of the units are listed.

The units must be protected against:

- Dirt,
- Corrosion,
- Water
- and an aggressive atmosphere.

6 Assembly and Alignment

The linear unit can be mounted as follows:

- With screws in the sliding blocks
- With screws in the factory-fitted threaded rails
- With screws (and pins) to the slide plate (AZSH version).

☛ Only mount the linear unit onto a flat surface. Standard parallelism <math><0.2\text{ mm}/1000\text{ mm}</math>.

☛ Mounting the linear unit via the threaded rails is recommended for the following situations:

- For highly dynamic applications
- For just 2 fixing points of the linear unit

6.1 Screw linear unit into place from underneath

(applies not to size 400)

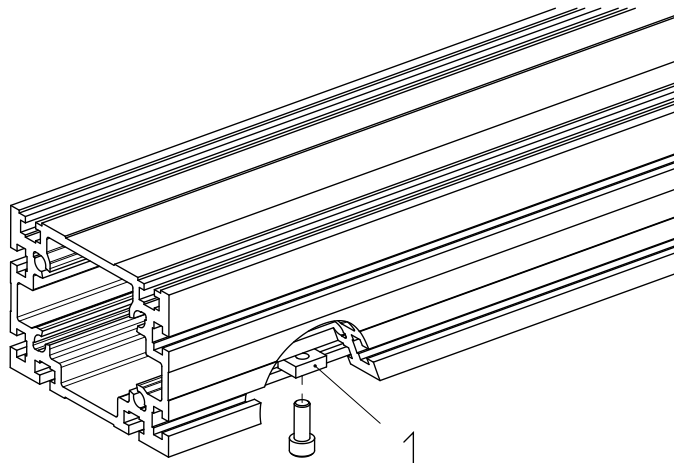

Image 2: Sliding blocks (1) in the groove on the underside of the basic profile

Secure the linear unit using fastening screws from below using the sliding blocks or the threaded rails in the basic aluminium profile (Image 2).

Proceed as follows:

1. Align the linear unit.
2. Align the sliding blocks (1) / threaded rails.
3. Screw the linear unit into place (Tightening torques, see Sec. 3).

6.2 Set maximum stroke

DANGER



Risk of serious injury from overturning transport devices.

Should the sliding carriage come to a stop beyond the safety area, the transport devices mounted to this can break off or overturn. This can damage the linear unit.

Please take note of the specified safety area when setting up the drive and set the limit switch correspondingly.

Electric switches may only be connected by a qualified electrician.

☛ Allow for a sufficient braking distance to ensure that there is enough time to slow down the sliding carriage in the case of an emergency stop.

6.3 Installing the drive

6.3.1 Installing the motor

Installation of the motor depends on the gears used and thus the relevant gear documentation.

7 Commissioning

WARNING



Risk of injury or damage to other installation parts due to quick linear movements of the transport devices, due to centrifugal load.
Only authorised personnel are permitted to operate the linear unit.

DANGER



Risk of crushing due to incorrect direction of movement of the transport devices.
Should the direction of rotation of the drive (motor or gear) and the sliding carriage drive (spindle or toothed belt) not correspond, the mounted transport devices may travel in the wrong direction. Around all rotating parts (e.g. GX shaft) there is a risk of being pulled in, and of clothing or body parts being caught up and trapped. There is also a risk of crushing around the moving carriage and the rack-and-pinion drive. These hazards can be countered by installing effective safety mechanisms that comply with the current standards and are state-of-the-art. These are not supplied with the linear unit and must be installed by the manufacturer of the overall installation.
Only qualified electricians are permitted to carry out any work on the electrical installation or check the direction of rotation.

Checking the unit before commissioning

Before commissioning, the following must be checked:

- whether the holding devices used are consistent with the mass and acceleration information provided by the manufacturer,
- whether the machine or installation in which the linear unit is installed corresponds to the provisions set out by the machinery directive, the harmonised standards, the European or national standards,
- whether the linear unit is correctly mounted
- whether the inductive and/or mechanical limit switch is correctly connected and functioning properly
- whether the direction of rotation of the motor shaft and, if applicable, the intermediary gear corresponds to the direction of rotation of the spindle or the toothed belt.

If there are faults detected during this inspection, the drive may not be started.

Test run

To prevent accidents, collisions and possible errors in the programming, move the linear unit along the stroke several times at such a low speed that it can be stopped in good time in case of an emergency.

The installation can be started up after it has been ensured that there is no risk of a collision when exceeding the maximum stroke.

8 Operation

WARNING



The drive motor can heat up considerably during operation. In this case, refer to the operating instructions supplied for the drive motor.

CAUTION



Risk of damage due to harmful environmental influences! The linear unit may only be operated under environmental conditions which are permitted by the manufacturer.

Environmental conditions

The linear unit may only be operated within the permitted temperature range of 0 - 80 °C.

Operating the unit in damp, abrasive conditions may result in foreign objects entering components in the linear unit. To prevent this, as part of the integration of the linear unit into the entire plant, measures may need to be taken to prevent foreign bodies from penetrating, e.g. using folding plates, baffle plates, sealing air.

Required inspection

The linear unit must be occasionally checked during operation to see that it is functioning correctly.

The personnel responsible must check the linear unit and the machinery for any visible signs of damage or defects at least once during each shift.

Should there be any changes observed which may compromise the safety of the drive, it must be switched off immediately.

Emergency stop

The maximum permissible load values must not be exceeded even in an emergency stop situation.

As a rule, the category 1 emergency stop strategy (targeted braking to standstill, then de-energise) is chosen for automation equipment with moving masses. A simple emergency stop strategy is not usually effective, as the masses are still moving and can cause damage.

End position damping

The end stops and stop buffers installed in our linear modules protect the unit at low speed (commissioning). They are definitely not intended to completely protect the unit against damage at high speed and/or with a large mass.

9 Decommissioning

WARNING



Risk of injury or damage to other installation parts due to falling parts.

Only authorised personnel are permitted to disassemble the linear unit.

1. Separate the machine/installation from the mains supply.
2. Disassemble the drive from the linear unit.
3. Unscrew the linear unit from the machine/installation.

10 Maintenance

DANGER



Around all rotating parts (e.g. GX shaft) there is a risk of being pulled in, and of clothing or body parts being caught up and trapped. There is also a risk of crushing around the moving carriage and the rack-and-pinion drive.

For this reason, lubrication of the linear unit may only be carried out while it is moving slowly (max. 0.025 m/s), and for any cleaning work the linear unit drive must be shut down and secured against being restarted.

- All mounted ball bearings are sealed and maintenance-free.
- Remove excessive dust and dirt from parts of the linear unit regularly.

10.1 Lubrication

Influencing factors The following influencing factors are important for an accurate regulation of lubrication intervals:

- Load
- Speed
- Motion sequence
- Operating temperature
- Degree of contamination

Short lubrication intervals Short lubrication intervals are required for:

- operation under the influence of dust and dampness
- a heavy load
- high speed (up to V_{max})

Short strokes
 (Short stroke design) Short stroke refers to a stroke with a value equal to or lower than that specified in the table. To achieve the best possible lubrication, relubrication should be carried out from both sides with guiding carriage short strokes and thus requires a special attachment. (Design feasibility must be checked.)

A lubrication stroke should also be carried out at least once per shift (8 hours) where possible.

Größe	12	15	20	25	25L	30	30L	35	35L
THK	40	95	120	140	175	160	210	185	250
Bosch-Rex.	40	80	100	115	160	135	180	155	210
Lubrication stroke	70	130	160	180	220	210	260	240	300

Initial lubrication

☛ After commissioning, carry out the initial lubrication. The basic lubrication has already been carried out by the manufacturer.

Refer to the lubrication regulations on the following pages.

Lubrication points for linear units

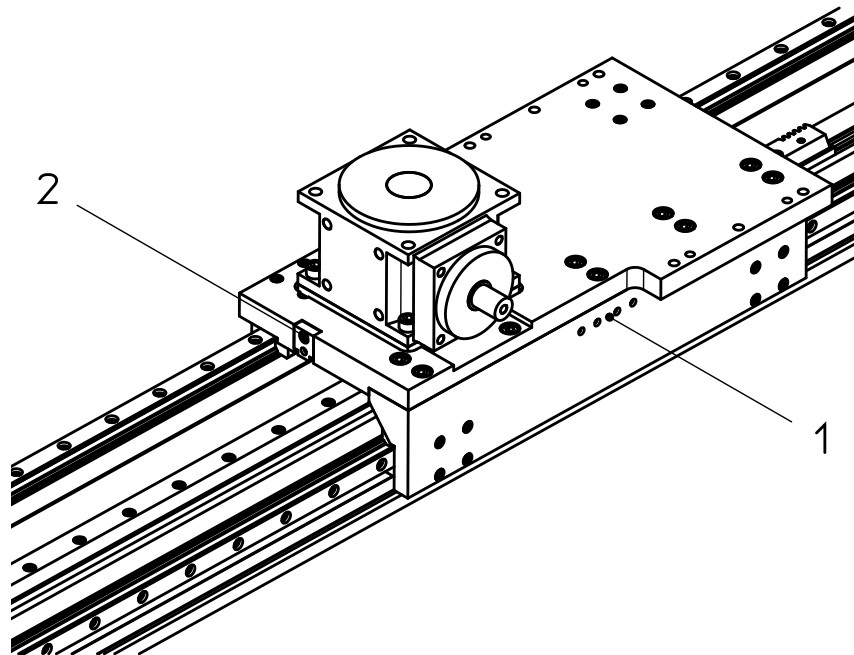

Image 3: Lubrication points (1 and 2) at sliding carriage

The lubrication points for the guides (1) are located on the side and supply one guide carriage each.

The lubrication point for the rack and pinion (2) is located on the front side of the carriage.

The lubrication plans outlined below apply for the lubrication points.

Lubrication method

Lubrication should take place as far as possible while in motion so that the grease is distributed and no pressure builds up.

Lubrication plan for guide carriage lubrication point (1)

Guide carriage size	Lubrication interval	Amount of grease [cm³] per guide carriage	Type of grease
15 with ball chain	approx. 5,000 km*	approx. 0.4	Grease in accordance with DIN51825-KP2N-20, e.g. Klüberplex BE 31-102 ⚠ Please take note of the instructions provided by the lubricant manufacturer should a different type of grease be used! ⚠ Grease with a solid lubricant percentage (e.g. graphite, MoS2) is not to be used!
20 with ball chain		approx. 0.6	
25(L) with ball chain		approx. 1.2	
35 with ball chain		approx. 1.7	
45L with ball chain		approx. 4.2	
15 without ball chain	approx. 2,000 km*	approx. 0.8	
20 without ball chain		approx. 1.4	
25(L) without ball chain		approx. 2.8	
35 without ball chain		approx. 4.4	
45L without ball chain		approx. 9.4	

**or at least twice a year. The lubrication interval depends on the environmental conditions and the load. Relubrication "in motion"!*

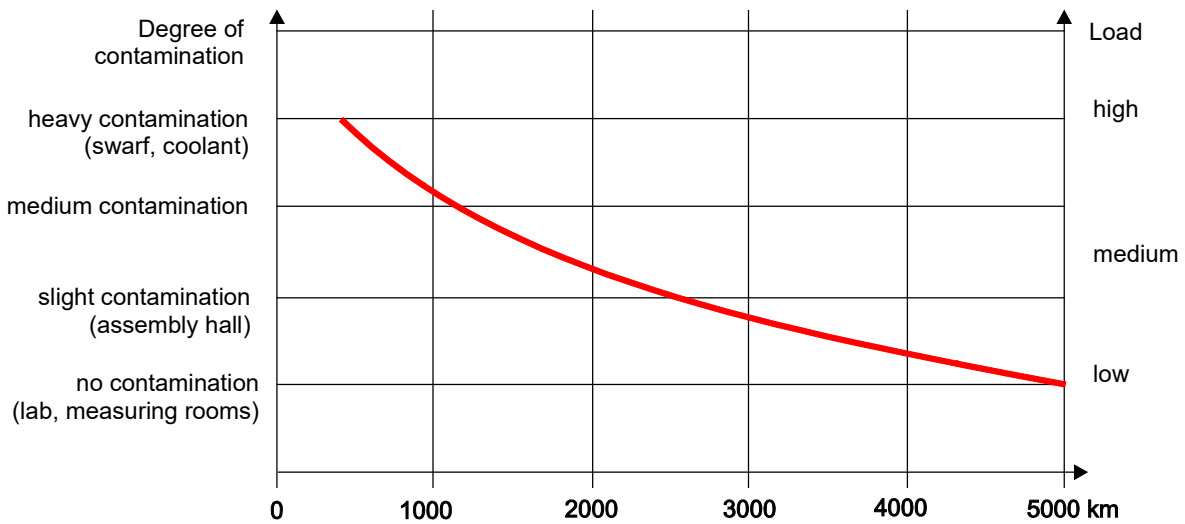
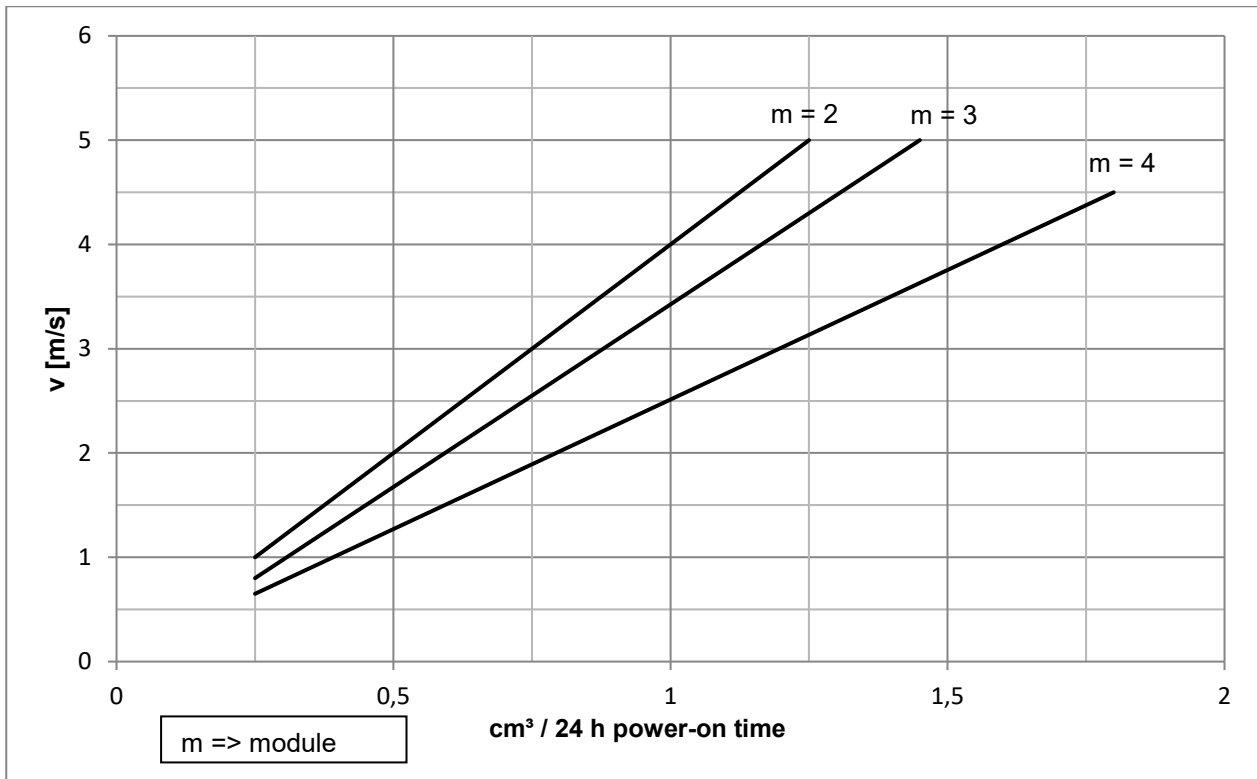

Image 4: Relubrication intervals for the linear guide system with ball chain

Lubrication plan for rack lubrication point (2)



Recommended lubricants:

Klüber Microlube GB0
Klüber Structovis AHD

Alternatives:

BP Energrease LS EP 00
Fuchs Lubritec Gearmaster ZSA
Molykote G-Rapid plus 3694

10.2 Your added value in service: Repair and Retrofit

In addition to installation and maintenance, we also offer professional repair and retrofit services for our products. You benefit from our expertise, fast fault diagnosis, and expert repairs – helping to extend the service life of your products and modernize existing systems.

For further information regarding repairs or retrofit solutions, please contact our customer service at service.greifsysteme@de.schunk.com.

We will be happy to advise you.