

# Assembly and Operating Manual

## WSG 32

Servo-electric 2-finger parallel gripper



Superior Clamping and Gripping

**SCHUNK** ®

## Imprint

### Copyright:

This manual is protected by copyright. The author is SCHUNK GmbH & Co. KG. All rights reserved.

### Technical changes:

We reserve the right to make alterations for the purpose of technical improvement.

**Document number:** 389575

**Version:** 06.00 | 12/05/2022 | en

Dear Customer,

thank you for trusting our products and our family-owned company, the leading technology supplier of robots and production machines.

Our team is always available to answer any questions on this product and other solutions. Ask us questions and challenge us. We will find a solution!

Best regards,

Your SCHUNK team

Customer Management

Tel. +49-7133-103-2503

Fax +49-7133-103-2189

[cmg@de.schunk.com](mailto:cmg@de.schunk.com)



**Please read the operating manual in full and keep it close to the product.**

## Table of Contents

<b>1</b>	<b>General</b> .....	<b>5</b>
1.1	About this manual .....	5
1.1.1	Presentation of Warning Labels .....	5
1.1.2	Applicable documents .....	6
1.2	Warranty .....	6
1.3	Scope of delivery .....	6
1.4	Accessories .....	6
<b>2</b>	<b>Basic safety notes</b> .....	<b>7</b>
2.1	Intended use.....	7
2.2	Not intended use.....	7
2.3	Constructional changes .....	7
2.4	Special standards.....	8
2.5	Spare parts .....	8
2.6	Gripper fingers .....	8
2.7	Environmental and operating conditions .....	9
2.8	Personnel qualification.....	9
2.9	Personal protective equipment.....	10
2.10	Notes on safe operation .....	10
2.11	Transport .....	11
2.12	Malfunctions.....	11
2.13	Disposal .....	11
2.14	Fundamental dangers.....	11
2.15	Notes on particular risks.....	12
<b>3</b>	<b>Technical data</b> .....	<b>13</b>
3.1	Outer dimensions .....	13
3.2	Nominal mechanical data .....	14
3.2.1	Permitted finger load.....	16
3.2.2	Gripping force.....	17
3.3	Nominal electrical data.....	19
3.3.1	Fuse .....	19
3.4	Interfaces and connections .....	20
3.4.1	Power supply .....	20
3.4.2	Ethernet.....	21
3.4.3	Base jaw with a sensor port.....	22
3.5	Name plate .....	24
<b>4</b>	<b>Design and description</b> .....	<b>25</b>
4.1	Design .....	25
4.2	Description .....	26

<b>5</b>	<b>Assembly .....</b>	<b>27</b>
5.1	Safety notes .....	27
5.2	Mechanical connection .....	28
5.3	Electrical connection .....	30
5.4	Installation of the fingers .....	32
<b>6</b>	<b>Start-up .....</b>	<b>33</b>
6.1	Initial commissioning .....	33
6.2	Changing the IP address and using DHCP .....	36
<b>7</b>	<b>Operation .....</b>	<b>37</b>
7.1	Operating software .....	38
7.2	Memory card .....	38
7.3	The boot process .....	39
7.4	Display of operating state .....	40
7.5	Status word and gripper state .....	42
	7.5.1 Status word .....	42
	7.5.2 Gripper state .....	43
7.6	Homing the product .....	45
7.7	Gripping, detecting parts to be gripped and monitoring the gripping .....	46
7.8	Software limit switch .....	48
7.9	Fast stops requiring acknowledgment .....	49
7.10	Log memory .....	50
7.11	Thermal monitoring .....	51
7.12	Monitoring the motor current .....	52
7.13	Monitoring the supply voltage .....	53
7.14	Configuration and diagnosis via the web interface .....	54
	7.14.1 Access restrictions for the web user interface .....	56
7.15	Command interface .....	57
7.16	Scripting .....	57
7.17	Resetting the configuration .....	58
7.18	Implementing the gripping process .....	58
<b>8</b>	<b>Maintenance and cleaning .....</b>	<b>60</b>
<b>9</b>	<b>Troubleshooting .....</b>	<b>61</b>
9.1	The gripper jaws don't move .....	61
9.2	Gripper stops abruptly .....	62
9.3	No connection to the web interface .....	62
<b>10</b>	<b>Translation of original declaration of incorporation .....</b>	<b>63</b>
<b>11</b>	<b>Annex to Declaration of Incorporation .....</b>	<b>64</b>

# 1 General

## 1.1 About this manual

This manual contains important information for a safe and appropriate use of the product.

This manual is an integral part of the product and must be kept accessible for the personnel at all times.

Before starting work, the personnel must have read and understood this operating manual. Prerequisite for safe working is the observance of all safety instructions in this manual.

Illustrations in this manual are provided for basic understanding and may differ from the actual product design.

In addition to these instructions, the documents listed under ▶ 1.1.2 [ 6 ] are applicable.

### 1.1.1 Presentation of Warning Labels

To make risks clear, the following signal words and symbols are used for safety notes.



#### **⚠ DANGER**

##### **Danger for persons!**

Non-observance will inevitably cause irreversible injury or death.



#### **⚠ WARNING**

##### **Dangers for persons!**

Non-observance can lead to irreversible injury and even death.



#### **⚠ CAUTION**

##### **Dangers for persons!**

Non-observance can cause minor injuries.

#### **CAUTION**

##### **Material damage!**

Information about avoiding material damage.

### 1.1.2 Applicable documents

- General terms of business \*
- Catalog data sheet of the purchased product \*
- Assembly and operating manuals of the accessories \*
- WSG Command Set Reference - Description of the command protocol (TCP/IP) \*
- WSG GCL Reference Manual - Description of the text-based command protocol (TCP/IP) \*
- WSG Fieldbus Interface Documentation - Description of the fieldbus interface (PROFINET, Modbus/TCP) \*
- WSG Scripting Reference Manual - Description of the script interpreter for the gripper control system \*

The documents labeled with an asterisk (\*) can be downloaded from [schunk.com](https://www.schunk.com).

## 1.2 Warranty

If the product is used as intended, the warranty is valid for 24 months from the ex-works delivery date under the following conditions:

- Observe the specified maintenance and lubrication intervals
- Observe the ambient conditions and operating conditions

Parts touching the workpiece and wear parts are not included in the warranty.

The product is considered defective if its basic function "gripping" is no longer given.

## 1.3 Scope of delivery

The scope of delivery includes

- Servo-electric 2-finger parallel gripper WSG 32 in the version ordered
- 3 m network cable M8 to RJ-45

## 1.4 Accessories

The following accessories, which must be ordered separately, are required for the product:

- Ethernet data cable, length 5 m, 10 m, 4-pole M8-connector straight, right angle to RJ-45, for WSG gripper
- Power supply cable length 5 m, shielded, 6-pole M8 connector straight, right angle to free wire ends
- Centering sleeves,  $\varnothing 6.0 \times 5.35$ , outer diameter 6h6
- Universal finger ABF WSG32/50-GV
- Force measurement finger ABF WSG32/50-DV

## 2 Basic safety notes

### 2.1 Intended use

The product is designed exclusively for gripping and temporarily holding workpieces or objects.

- The product may only be used within the scope of its technical data, ▶ 3 [□ 13].
- When implementing and operating components in safety-related parts of the control systems, the basic safety principles in accordance with DIN EN ISO 13849-2 apply. The proven safety principles in accordance with DIN EN ISO 13849-2 also apply to categories 1, 2, 3 and 4.
- The product is intended for installation in a machine/system. The applicable guidelines must be observed and complied with.
- The product is intended for industrial and industry-oriented use.
- Appropriate use of the product includes compliance with all instructions in this manual.

### 2.2 Not intended use

It is not intended use if the product is used, for example, as a pressing tool, stamping tool, lifting gear, guide for tools, cutting tool, clamping device or a drilling tool.

- Any utilization that exceeds or differs from the appropriate use is regarded as misuse.

### 2.3 Constructional changes

#### Implementation of structural changes

By conversions, changes, and reworking, e.g. additional threads, holes, or safety devices can impair the functioning or safety of the product or damage it.

- Structural changes should only be made with the written approval of SCHUNK.

## 2.4 Special standards

The following standards are met:

- Fast transients on supply and I/O lines (burst) to IEC / EN 61000-4-4
- HF power supply to IEC/EN 61000-4-6
- HF radiation according to IEC/EN 61000-4-3
- Emissions according to EN 55011:2009 Class A (corresponds to EN 61000-6-4:2007)
- Magnetic field with energy technical frequency according to EN 61000-4-8

## 2.5 Spare parts

### Use of unauthorized spare parts

Using unauthorized spare parts can endanger personnel and damage the product or cause it to malfunction.

- Use only original spare parts or spares authorized by SCHUNK.

## 2.6 Gripper fingers

### Requirements of gripper fingers

Accumulated energy can make the product unsafe and risk the danger of serious injuries and considerable material damage.

- Execute the gripper fingers in such a way that the product reaches either the "open" or "closed" position in a de-energized state.
- Only change gripper fingers if no residual energy can be released.
- Make sure that the product and the top jaws are a sufficient size for the application.

## 2.7 Environmental and operating conditions

### Required ambient conditions and operating conditions

Incorrect ambient and operating conditions can make the product unsafe, leading to the risk of serious injuries, considerable material damage and/or a significant reduction to the product's life span.

- Make sure that the product is used only in the context of its defined application parameters, ▶ 3 [□ 13].
- Observe Maintenance intervals, ▶ 8 [□ 60].
- Make sure that the environment is clean and the ambient temperature corresponds to the specifications per the catalog.

## 2.8 Personnel qualification

### Inadequate qualifications of the personnel

If the personnel working with the product is not sufficiently qualified, the result may be serious injuries and significant property damage.

- All work may only be performed by qualified personnel.
- Before working with the product, the personnel must have read and understood the complete assembly and operating manual.
- Observe the national safety regulations and rules and general safety instructions.

The following personal qualifications are necessary for the various activities related to the product:

<b>Trained electrician</b>	Due to their technical training, knowledge and experience, trained electricians are able to work on electrical systems, recognize and avoid possible dangers and know the relevant standards and regulations.
<b>Qualified personnel</b>	Due to its technical training, knowledge and experience, qualified personnel is able to perform the delegated tasks, recognize and avoid possible dangers and knows the relevant standards and regulations.
<b>Instructed person</b>	Instructed persons were instructed by the operator about the delegated tasks and possible dangers due to improper behaviour.
<b>Service personnel of the manufacturer</b>	Due to its technical training, knowledge and experience, service personnel of the manufacturer is able to perform the delegated tasks and to recognize and avoid possible dangers.

## 2.9 Personal protective equipment

### Use of personal protective equipment

Personal protective equipment serves to protect staff against danger which may interfere with their health or safety at work.

- When working on and with the product, observe the occupational health and safety regulations and wear the required personal protective equipment.
- Observe the valid safety and accident prevention regulations.
- Wear protective gloves to guard against sharp edges and corners or rough surfaces.
- Wear heat-resistant protective gloves when handling hot surfaces.
- Wear protective gloves and safety goggles when handling hazardous substances.
- Wear close-fitting protective clothing and also wear long hair in a hairnet when dealing with moving components.

## 2.10 Notes on safe operation

### Incorrect handling of the personnel

Incorrect handling and assembly may impair the product's safety and cause serious injuries and considerable material damage.

- Avoid any manner of working that may interfere with the function and operational safety of the product.
- Use the product as intended.
- Observe the safety notes and assembly instructions.
- Do not expose the product to any corrosive media. This does not apply to products that are designed for special environments.
- Eliminate any malfunction immediately.
- Observe the care and maintenance instructions.
- Observe the current safety, accident prevention and environmental protection regulations regarding the product's application field.

## 2.11 Transport

### Handling during transport

Incorrect handling during transport may impair the product's safety and cause serious injuries and considerable material damage.

- When handling heavy weights, use lifting equipment to lift the product and transport it by appropriate means.
- Secure the product against falling during transportation and handling.
- Stand clear of suspended loads.

## 2.12 Malfunctions

### Behavior in case of malfunctions

- Immediately remove the product from operation and report the malfunction to the responsible departments/persons.
- Order appropriately trained personnel to rectify the malfunction.
- Do not recommission the product until the malfunction has been rectified.
- Test the product after a malfunction to establish whether it still functions properly and no increased risks have arisen.

## 2.13 Disposal

### Handling of disposal

The incorrect handling of disposal may impair the product's safety and cause serious injuries as well as considerable material and environmental harm.

- Follow local regulations on dispatching product components for recycling or proper disposal.

## 2.14 Fundamental dangers

### General

- Observe safety distances.
- Never deactivate safety devices.
- Before commissioning the product, take appropriate protective measures to secure the danger zone.
- Disconnect power sources before installation, modification, maintenance, or calibration. Ensure that no residual energy remains in the system.
- If the energy supply is connected, do not move any parts by hand.
- Do not reach into the open mechanism or movement area of the product during operation.

## 2.15 Notes on particular risks



### **⚠ WARNING**

#### **Risk of injury from objects falling and being ejected!**

Falling and ejected objects during operation can lead to serious injury or death.

- Take appropriate protective measures to secure the danger zone.



### **⚠ WARNING**

#### **Risk of injury from crushing and impacts!**

Serious injury could occur during movement of the base jaw, due to breakage or loosening of the gripper fingers or if the workpiece is lost.

- Wear suitable protective equipment.
- Do not reach into the open mechanism or the movement area of the product.



### **⚠ WARNING**

#### **Risk of injury due to unexpected movements!**

If the power supply is switched on or residual energy remains in the system, components can move unexpectedly and cause serious injuries.

- Before starting any work on the product: Switch off the power supply and secure against restarting.
- Make sure, that no residual energy remains in the system.

### 3 Technical data

#### 3.1 Outer dimensions

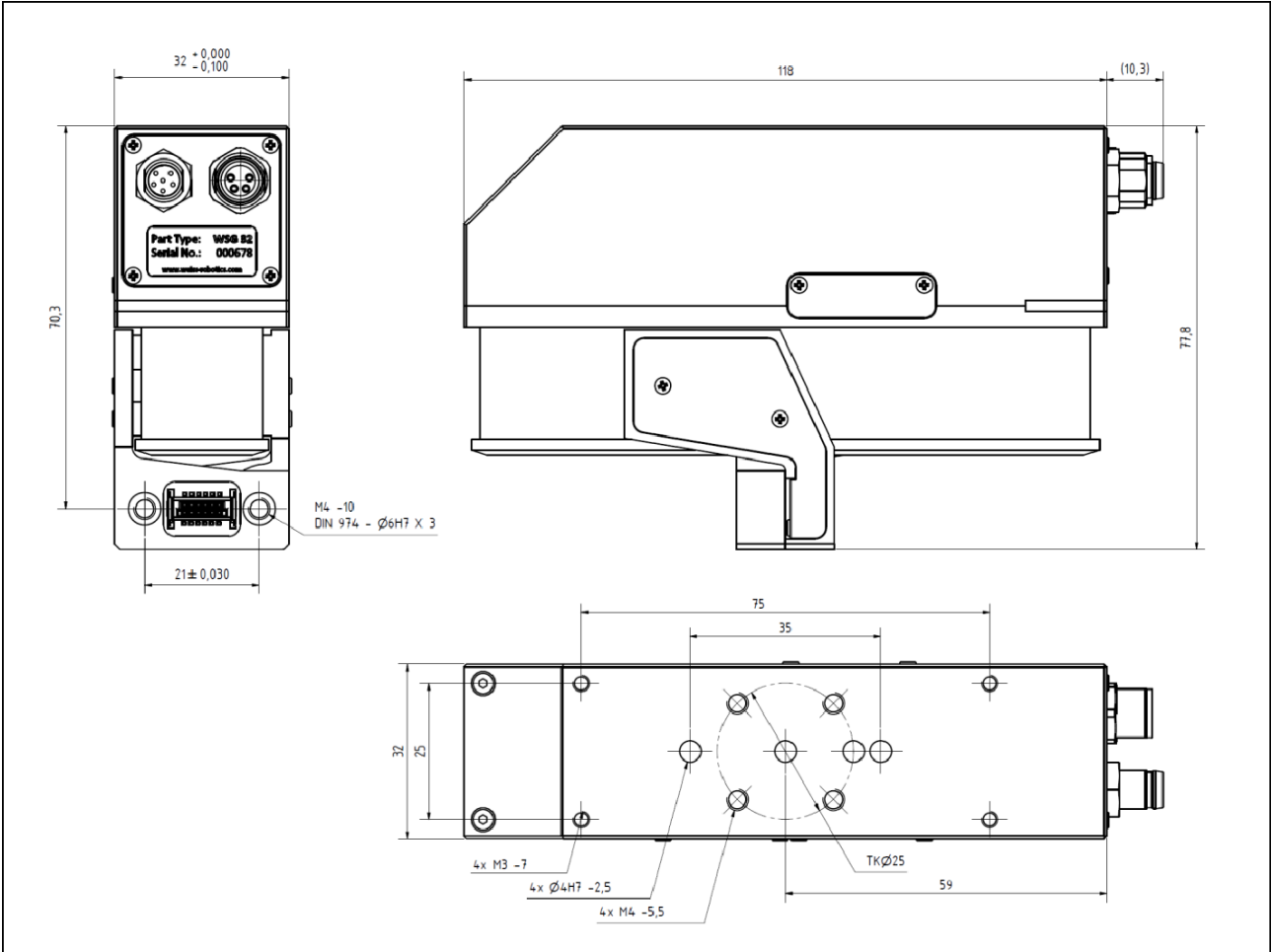

Outer dimensions

### 3.2 Nominal mechanical data

#### CAUTION

Exceeding the specified nominal data can damage the product.

- If in doubt, please discuss your application with SCHUNK.

Mechanical operating data	Value	Note
Stroke per finger [mm]	34	
Nominal gripping force [N]	50	Grip force approximation via motor current
Min.Gripping force [N]	5	Gripping speed 5 mm/s, finger length 55 mm, steel on steel
Max.Gripping force [N]	50	Gripping speed 50 mm/s, finger length 55 mm, steel on steel
Weight [kg]	0.55	
Recommended workpiece weight [kg]	0.5	
Max. permissible finger length [mm]	120	at nominal force, see following figure "Determining the clamping height"
Max. permitted weight per finger [kg]	0.1	
IP rating	40	DIN EN 60529
Ambient temperature [°C]		
Min.	0	
Max.	50	
Air humidity [%]		non condensing
Min.	0	
Max.	90	
Repeatability [mm]	±0.005	3σ-divergence
Gripping speed [mm/s]		
Min.	5	
Max.	400	
Finger acceleration [mm/s <sup>2</sup> ]		
Min.	100	
Max.	5000	

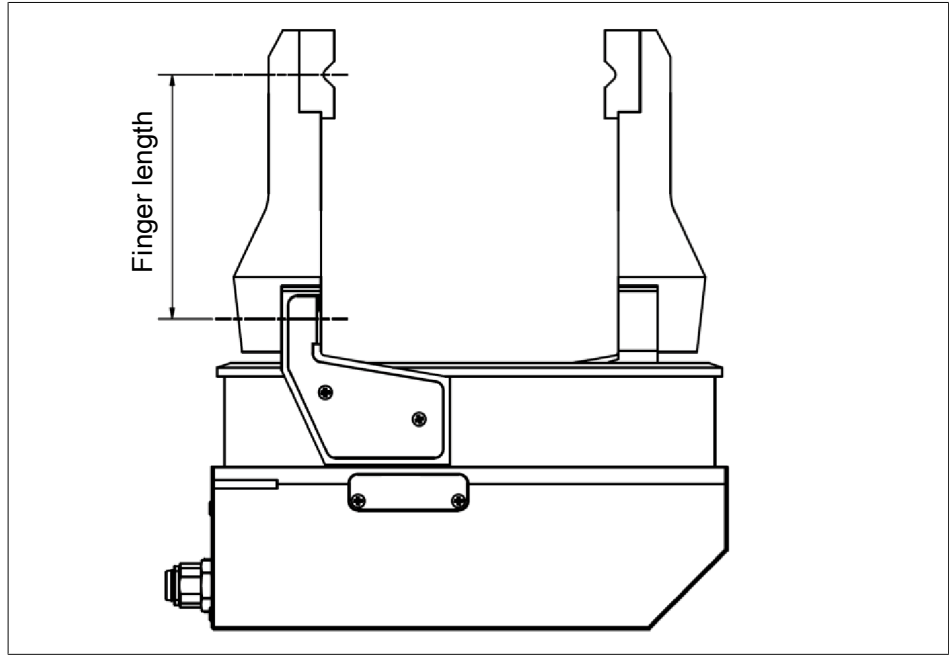

Determining the clamping height

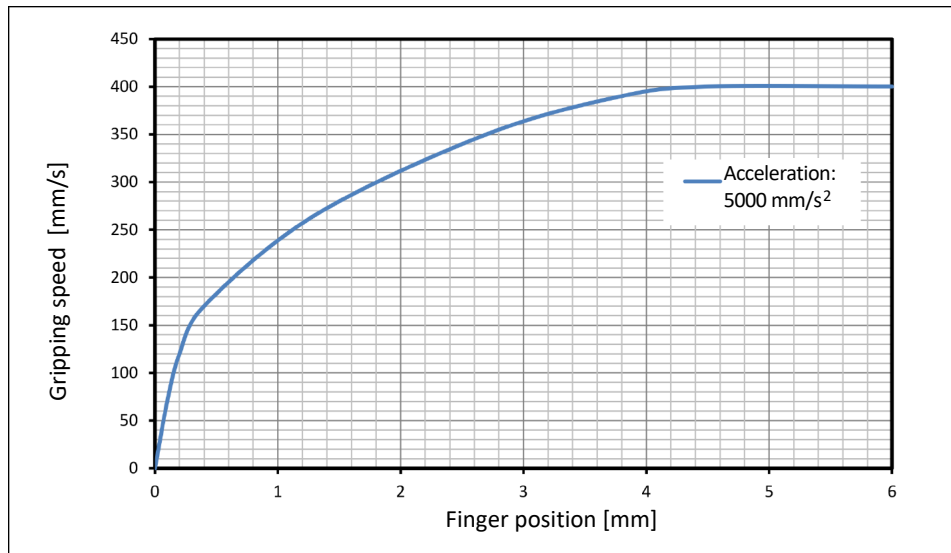

Typical finger acceleration, gripping force: 50 N, finger mass: 2x 0.1 kg

### 3.2.1 Permitted finger load

The following table shows the permitted load of the finger. The specified load may be applied simultaneously and in addition to the gripping force.

Mechanical Load	Value
$F_z$ [N], max.	50
$M_x$ [Nm], max.	1.6
$M_y$ [N], max.	1.6
$M_z$ [N], max.	1

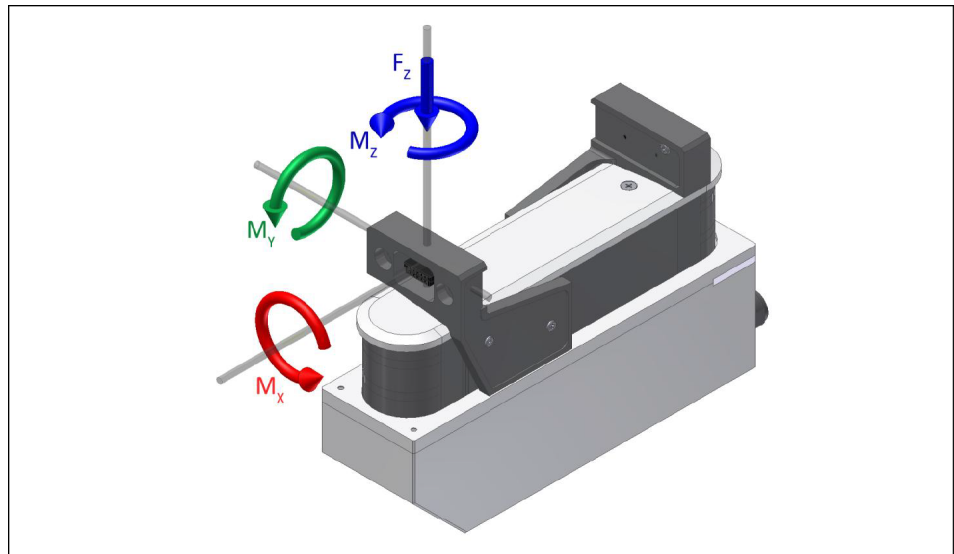

Finger load

### 3.2.2 Gripping force

The gripping force of the product is defined as the effective force acting between the fingers multiplied by the number of fingers in contact with the part to be grasped.

To operate the gripping product without force measurement fingers, the gripping force is calibrated during the manufacturing process.

The actual gripping force depends on gripping speed, finger length and temperature. Following figure "Recommended gripping speed" shows the recommended gripping speed according to the desired gripping force. The typical influence of the finger to the effective gripping force is shown in following "Gripping force over clamping height diagram".

#### NOTE

**For a precise control of the gripping force use the Force Measurement Finger ABF WSG32/50-DV (available as an accessory)**

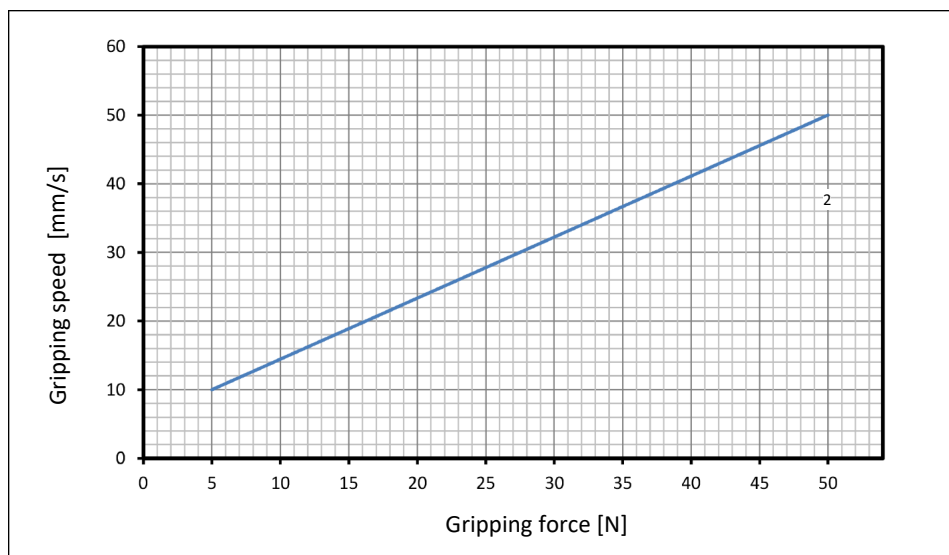

*Recommended gripping speed (steel on steel, finger length: 55 mm)*

#### NOTE

**The diagram above is considered as a recommendation. If in doubt, please try out and measure the actual force for your application.**

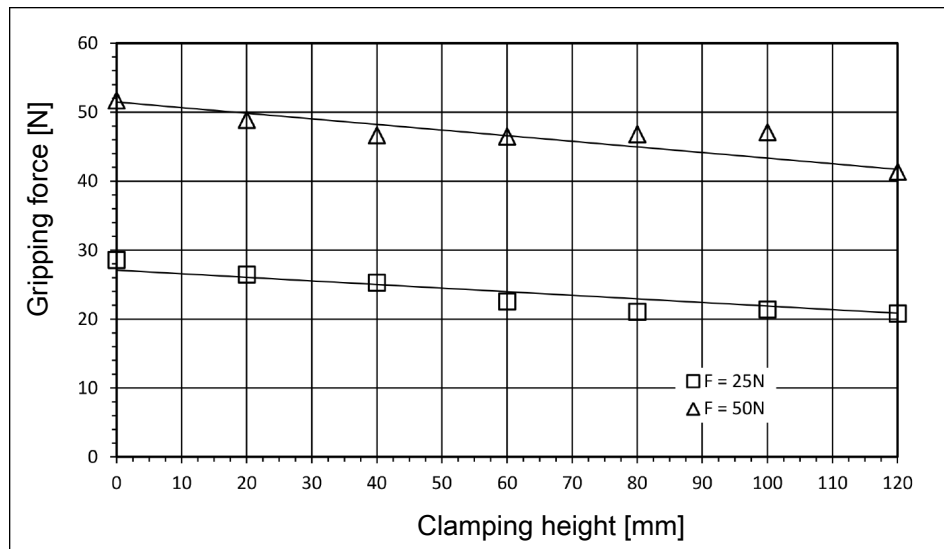

Gripping force in dependency of the finger length (exemplary)

### Definition of the nominal gripping force

To determine the nominal gripping force, the product is non-positively mounted to an aluminum plate, see following figure. The plate itself is thermally insulated from the underlying surface. With an ambient temperature of 22° C the product can hold with the nominal gripping force for at least 5 hours.

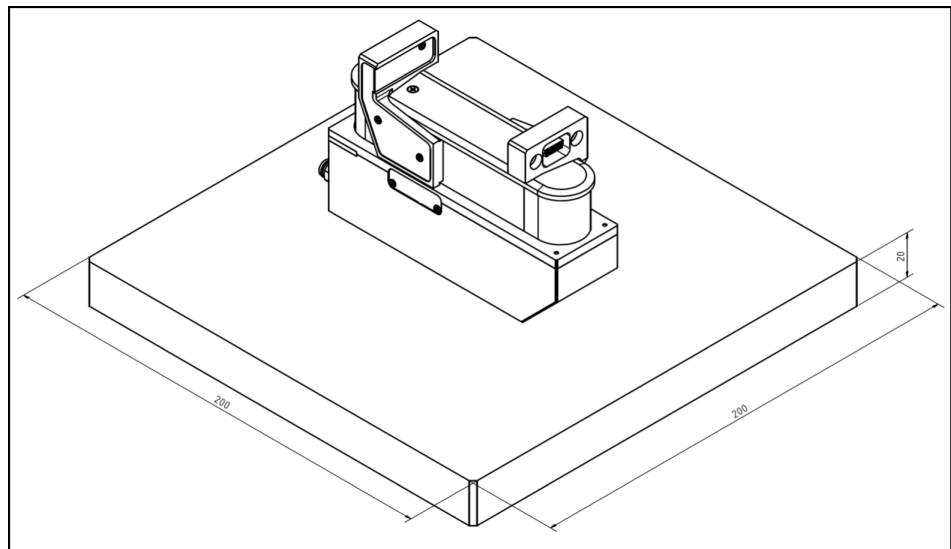

Arrangement for ascertaining the nominal gripping force

### CAUTION

**For high gripping forces or long holding cycles, make sure that heat is well dissipated via the screw contact surface. Damage to the product is possible!**

### 3.3 Nominal electrical data

#### **CAUTION**

**Exceeding the specified nominal data can damage the product.**

- If in doubt, please discuss your application with SCHUNK.

Electrical operating data	Value	Note
Terminal voltage [V DC]		
Min.	22	
Typical	24	
Max.	28	
Current input in idle state [A]	0.05	
Current input when holding [A]	0.75	Gripping force=50N
Position resolution [ $\mu\text{m}$ ]	1.3	
Controller	integrated	
Command interface	Ethernet PROFINET (optional)	
Parametrized interface	web-based	

#### 3.3.1 Fuse

The product has an integrated fuse to protect against short circuits and incorrect polarity.

**To have the fuse changed, please contact SCHUNK (Tel. +49 7133-103-2333).**

### 3.4 Interfaces and connections

The product has different interfaces for controlling. The selection of the communication interface goes on via the web-surface ▶ 7.14 [□ 54].

#### 3.4.1 Power supply

Power is supplied via a six-pin M8 plug connector (male) on the product housing

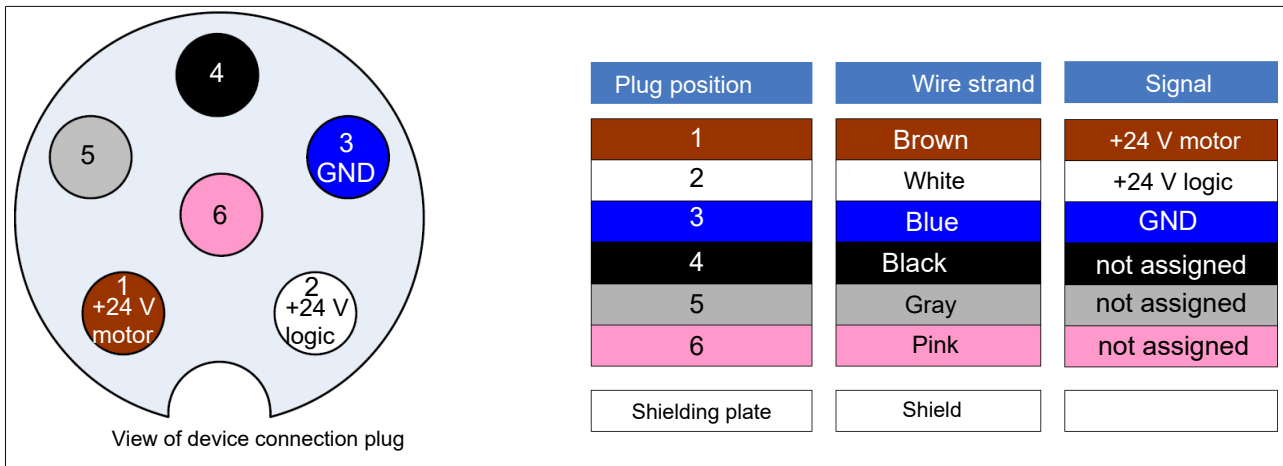

Connection assignment of the plug connector for the power supply

#### Requirement for the voltage supply:

- Voltage supply: 24 V DC  $\pm 10\%$
- Ripple < 150 mV<sub>SS</sub>
- Available output current: at least 3 A

The following cables from SCHUNK are suitable for connecting the voltage supply:

- KA GLN0806-LK-00500-A power cable 5 m, 6-pin M8 connector, straight on free conductor end, ID 0307787
- Type: KA WLN0806-LK-00500-A power cable 5 m, 6-pin M8 connector, angled on free conductor end, ID 0307785

### 3.4.2 Ethernet

The Ethernet interface can be used both for commands as well as for configuration via the integrated web server. It is presented via a 4-way M8 connector (socket).

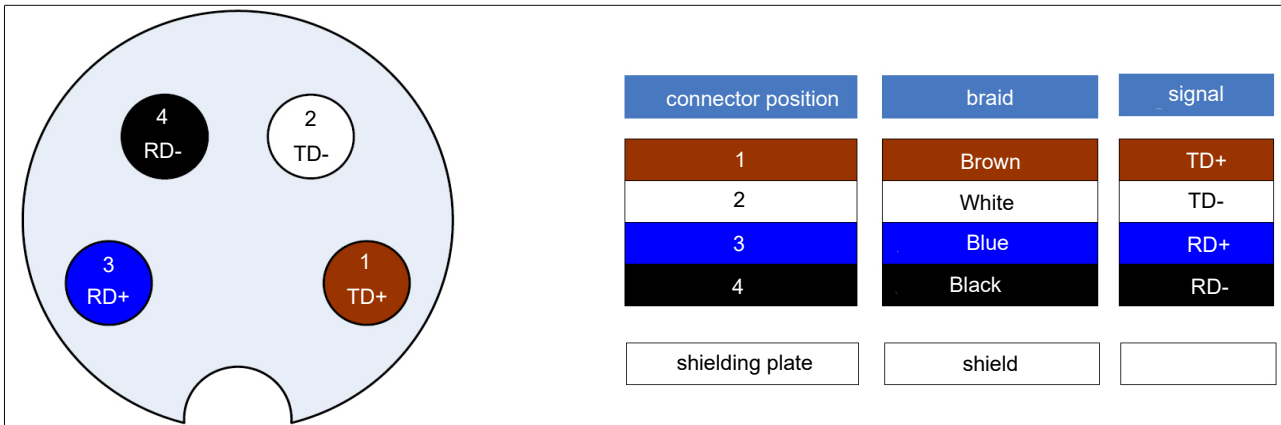

Pin assignment of the Ethernet connector (view on the socket).

The following cables are suitable to connect the Ethernet interface:

- Type: KA GGN0804-PG-00300-R Ethernet cable, length 3m, 4 pole M8 connector straight to RJ-45, Ident-No. 0349620
- Type: KA GGN0804-PG-00500-R Ethernet cable, length 5m, 4 pole M8 connector straight to RJ-45, Ident-No. 0349621

Commands are sent to the product via TCP/IP connections, using the TCP or UDP protocol. For further information, please see the "WSG Command Set Reference Manual" (can be called up via the web interface).

The product currently also supports the following network services:

- DHCP (dynamic IP addresses)
- SNTP (network time)
- HTTP (web user interface)
- DNS (resolution of host names)
- mDNS (decentralized resolution of host names)

#### Interface specification:

Parameter	Value	Note
Transmission standard	IEEE 802.3	
Communication standard	TCP/IP (IPv4)	
Transmission speed [MBit/s]	10; 100	Auto-Negotiated
Transmission type	Half duplex	
Auto-MDIX	yes	

### 3.4.3 Base jaw with a sensor port

The product has an integrated sensor port in each of the base jaws which makes it easy to connect intelligent gripper fingers. The sensor port makes the following interfaces available:

- UART (LVTTTL Levels)
- SPI (LVTTTLlevels)
- Digital I/O pin (LVTTTL levels)

The sensor port supports the automatic configuration of the connected fingers. To use this function, a configuration memory must be integrated into the fingers. All of the intelligent fingers offered by SCHUNK for this gripper (e.g. force measurement finger) already have this memory integrated and are completely configured, so that you just have to fit this finger to the product. The fingers will then be automatically detected the next time the system starts.

The sensor port supplies an operating voltage of 5 V  $\pm$ 10% at max. 200 mA. The supply voltage is protected against short circuits and can be switched on and off from the gripper control system. A short circuit in the supply voltage will trigger an error state which must be acknowledged.

---

#### NOTE

**The power supply from the sensor port is not suitable to supply actuators.**

---

#### **CAUTION**

**The gripper control system may be destroyed by excess voltage on the sensor port pins!**

---

The digital pins on the sensor port are protected against electrostatic discharge. However, SCHUNK still recommends that you should not directly touch the pins on the connector with fingers, to avoid damage from electrostatic discharge. The SPI and UART digital interfaces share transmit and receive pins. The configuration memory determines which function is active.

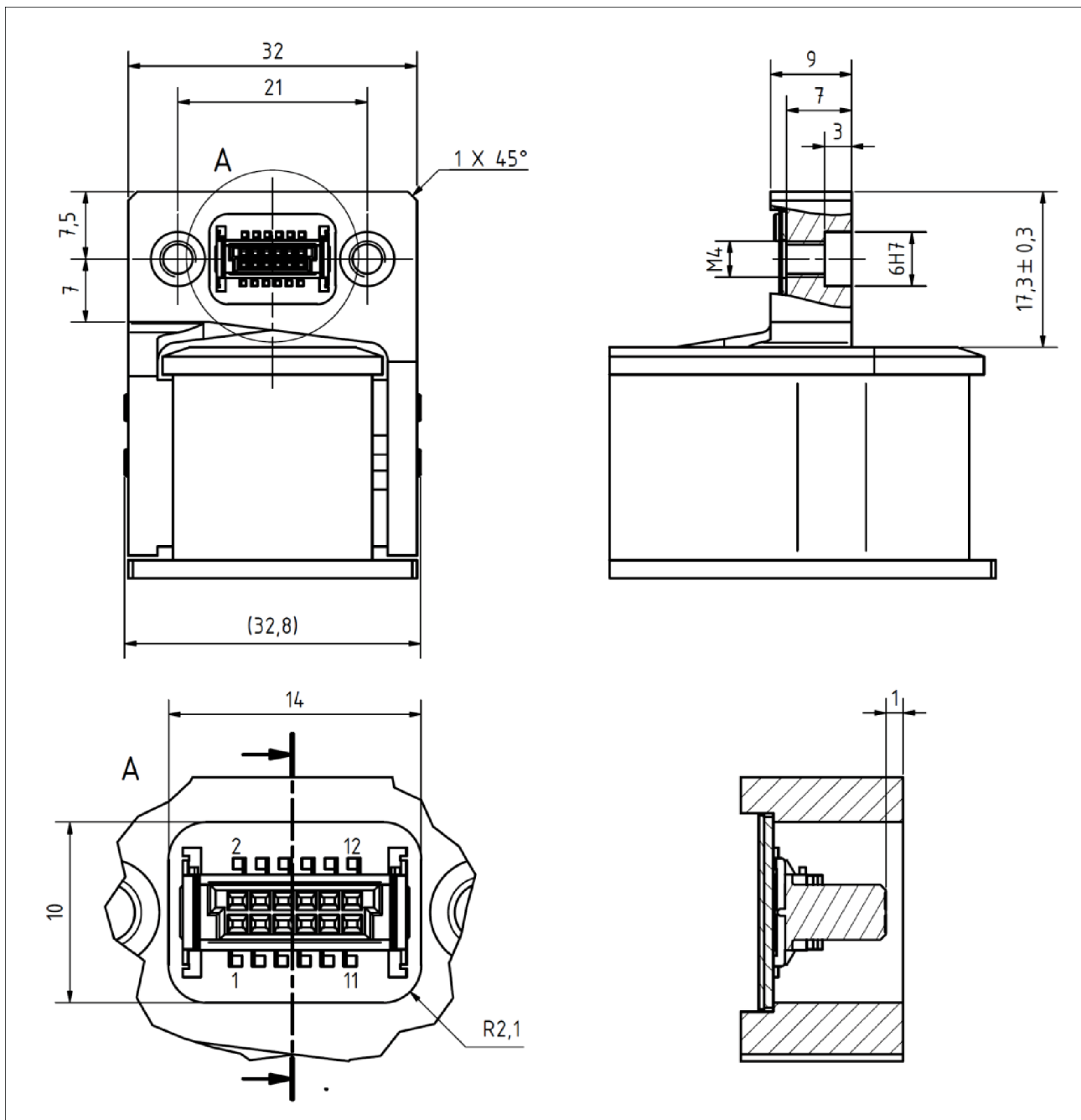

Sensor port

**Should you require detailed specifications of the sensor port to implement your own fingers, please contact SCHUNK.**

#### **Matching centering sleeves**

Matching centering sleeves are supplied with the fingers. For your own designs or as a spare part, please use the centering sleeves which are available as accessories, described as: centering sleeve  $\varnothing 6.0 \times 5.35$  (outer diameter: 6h6).

#### **Sensorport connector type**

Manufacturer: ERNI, type: SMC-B-12 (terminal strip), part number: 154805  
Counterpiece: SMC-Q-12 (male, low-profile connector), part number: 154818

### Sensor port connector pin assignments

Pin number	Name	Direction	Function
1	MOSI/TXD	OUT	SPI/UART: Transmit data from the manual controller
2	nSSEL	OUT	Only SPI: A low signal selects the slave
3	DIO	I/O	Digital I/O pin
4	SCLK	OUT	Only SPI: Clock for transmit and receive data
5	CFG-SDA	I/O	Configuration bus – data line
6	MISO/RXD	IN	SPI/UART: Received data
7	CFG-SCL	OUT	Configuration bus – clock line
8	NC	-	not connected
9	+5V	OUT	Operating voltage output 5V/200mA max.
10	+5V		
11	GND	OUT	Mass
12	GND		

### 3.5 Name plate

The name plate is on the narrow side of the product above the connector. It shows the type and the serial number of the product.

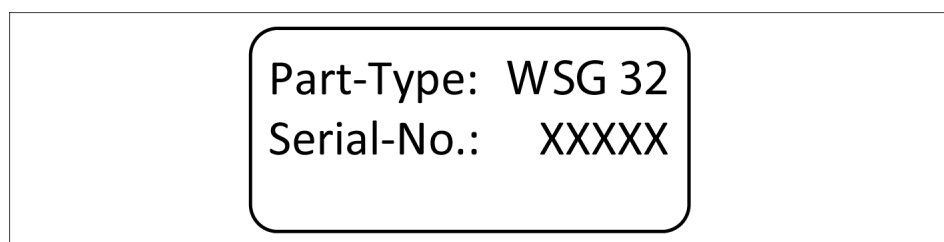

## 4 Design and description

### 4.1 Design

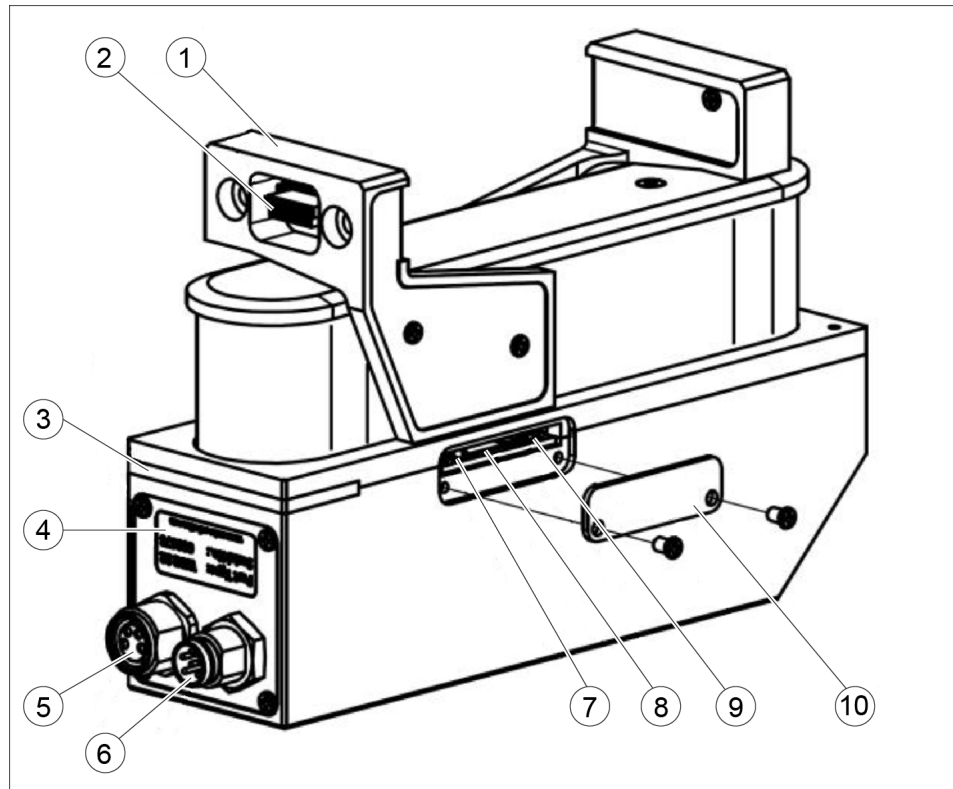

Components and connections for the WSG 32

Item	Designation
1	Base jaws
2	Sensor port
3	Operating condition display
4	Name plate
5	Ethernet connection
6	Power supply
7	Button for configuration reset
8	Memory card
9	Communication LEDs
10	Control shaft cover

## 4.2 Description

The product is a servo-electric compact gripper with covered guides and a powerful brushless drive. It is equipped with an integrated gripper control system that supports the following interfaces: Ethernet TCP/IP, PROFINET (optional) and Modbus/TCP (optional).

The previous illustration shows the connections and components of the product. The product is configured via a web interface and can be used with any standard browser. Furthermore, the product is equipped with a sensor port in the base jaws as standard.

Gripper fingers with integrated sensor technology can be connected here, and can be directly evaluated by the gripper control. SCHUNK offers standardized fingers as accessories, which also work in direct coordination with the gripper controller. For more information, please contact SCHUNK.

## 5 Assembly

### 5.1 Safety notes



#### **⚠ DANGER**

##### **Risk of fatal injury due to electric current!**

Touching live parts poses an immediate risk of fatal injury by electrocution.

- Only allow a qualified electrician to perform work on electrical components.
- Prior to commencing work on electric components, restore to a de-energized state.
- In case of damage to the insulation, switch off the power supply immediately and arrange for a repair.
- Keep humidity away from live parts.



#### **⚠ WARNING**

##### **Risk of injury due to unexpected movements!**

If the power supply is switched on or residual energy remains in the system, components can move unexpectedly and cause serious injuries.

- Before starting any work on the product: Switch off the power supply and secure against restarting.
- Make sure, that no residual energy remains in the system.



#### **⚠ WARNING**

##### **Risk of burns through contact with hot surfaces!**

Surfaces of components can heat up severely during operation. Skin contact with hot surfaces causes severe burns to the skin.

- For all work in the vicinity of hot surfaces, wear safety gloves.
- Before carrying out any work, make sure that all surfaces have cooled down to the ambient temperature.

## 5.2 Mechanical connection

The threads and centering holes which can be used to mount the product are shown in the following figure.

The product has M3 and M4 threads for fixing on the rear of housing, as well as  $\varnothing$  6 mm centering holes. The M4 threads together with the centering holes form part of the 50 mm ISO standard flange for industrial robots.

When in holding mode, the product constantly adjusts the gripping force, to ensure a constant gripping force. The surfaces which are screwed together must be capable of dissipating the resulting heat.

### **CAUTION**

#### **Risk of overheating!**

- Please ensure that the thermal coupling is good, especially if the product is to apply high gripping forces over longer periods of time.
- Prevent exposure to external sources of heat, such as from your robot's pan-tilt unit, as this can reduce the product's performance.
- Poor dissipation of heat or exposure to additional heat will require the gripping force to be reduced.

---

#### **NOTE**

**To ensure fault-free operation and to minimize the radiation of electromagnetic interference (EMC) the product's housing must be properly earthed.**

---

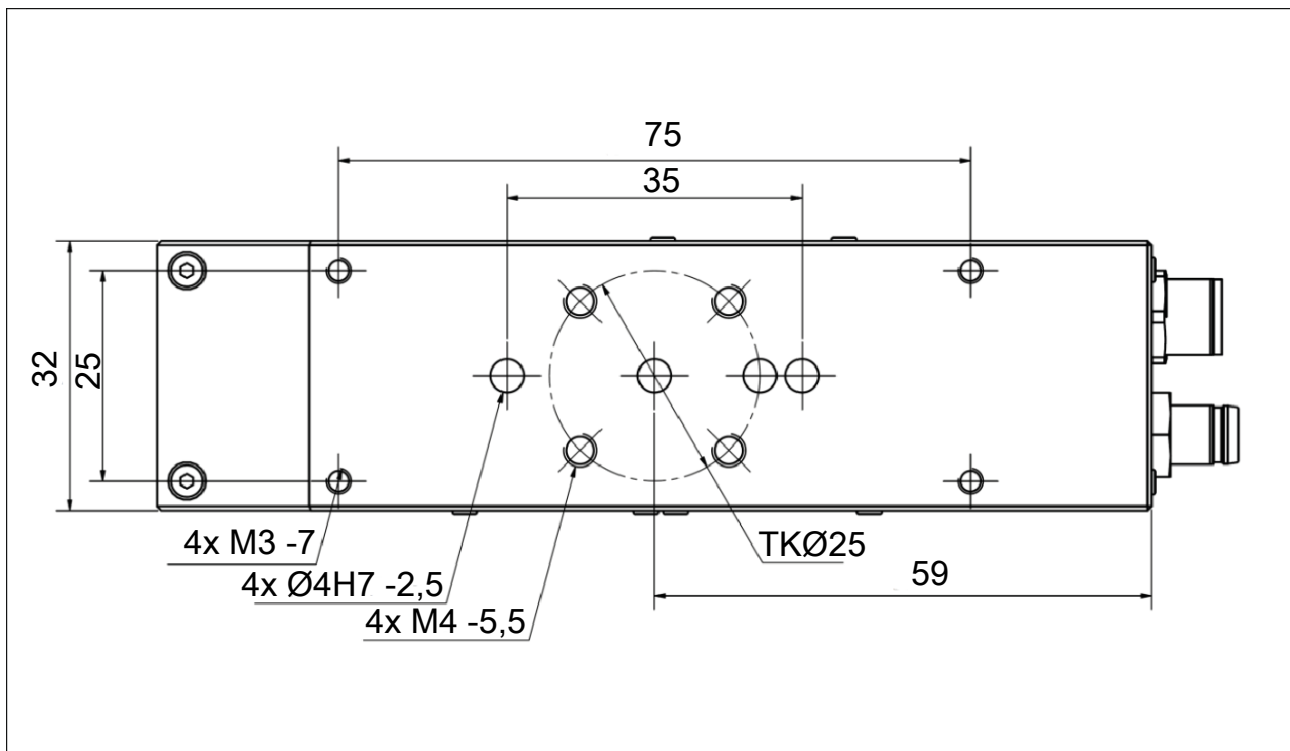

### CAUTION

#### Material damage due to incorrect tightening torques!

Observe the maximum tightening torque:

- Screw M3: 1.0 Nm
- Screw M4: 2.0 Nm

### 5.3 Electrical connection

As supplied, the product is configured so that the M8 connector carries both the power as well as the logic parts for the integrated gripper control system. If your application requires the power and logic parts to be separated, for instance if you would like to use an external relay to ensure that the gripping force is safely switched off (cf. "safe torque off", STO), then the power and logic parts can be supplied separately (see Fig. "Equivalent circuit for the power supply"). The power and logic supply are not electrically isolated so they must use the same power supply unit (see Fig. "Connection type common supply to load and logic"). If the supply to the load is to be switchable in operation, then the connection can be arranged as shown in "Connection type supply to load separate from supply to logic".

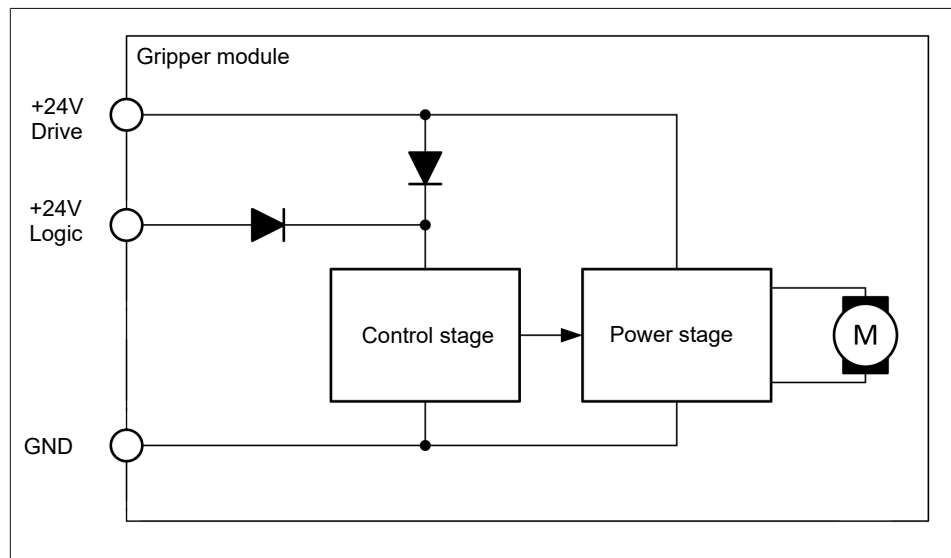

Equivalent circuit for the power supply

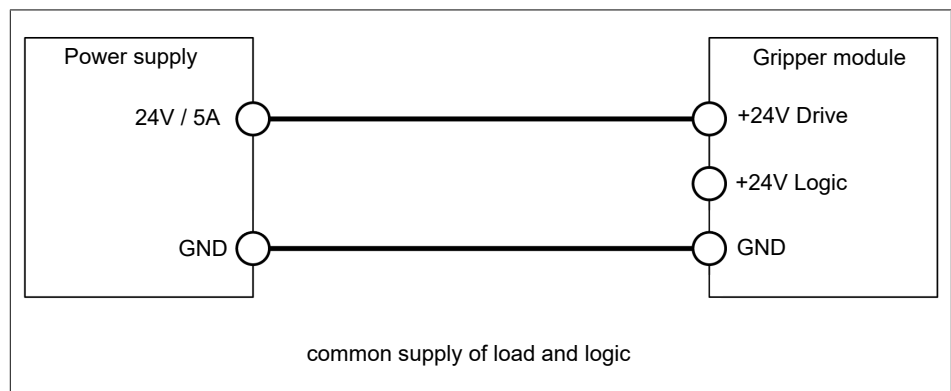

Connection type common supply to load and logic

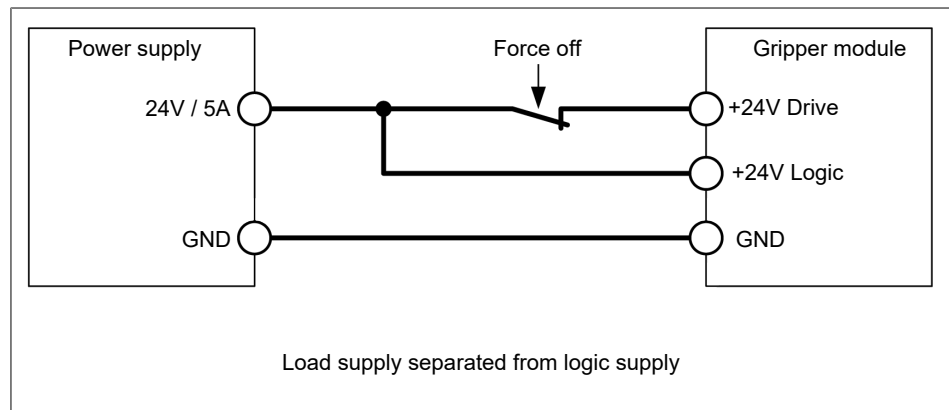

*Connection type supply to load separate from supply to logic*

**NOTE**

**If load and logic are operated separately, always use the same power supply!**

### 5.4 Installation of the fingers

To install the standard fingers, please use the fixing material supplied with the fingers. The centering sleeves supplied with the fingers must be used during the installation. This is particularly necessary if the finger has an electrical interface to the sensor port as otherwise the sensor port's connector can be damaged.

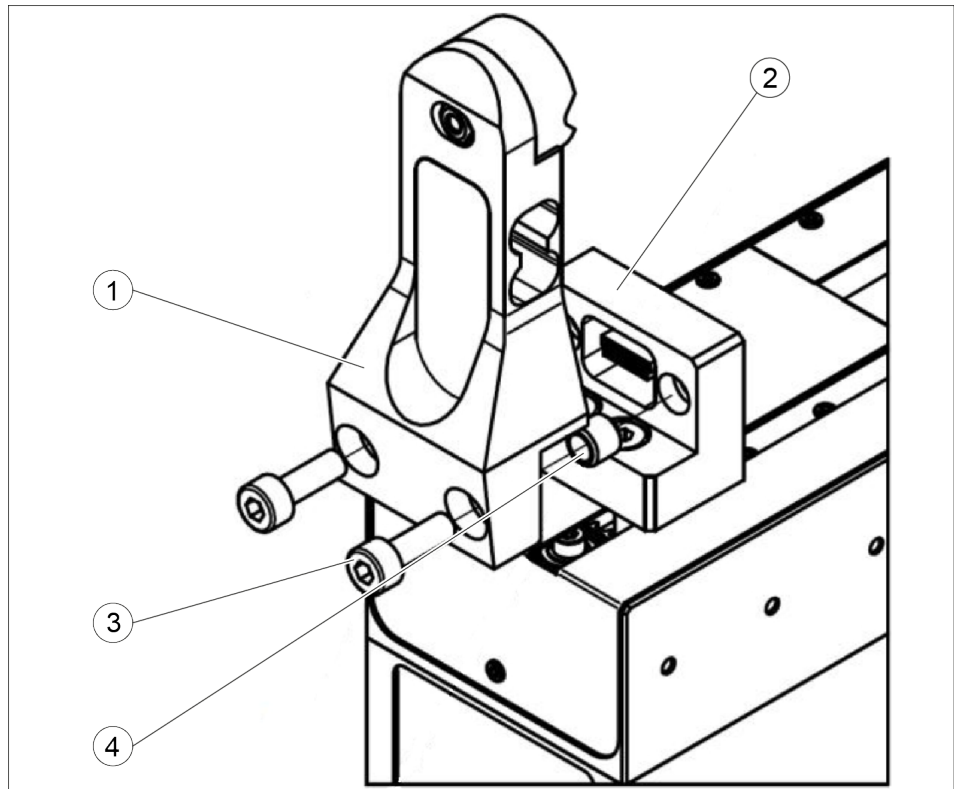

*Installation of the fingers*

1	Force measurement finger ABF WSG32/50-DV	2	Base jaw
3	Screw M4, ISO 4762 <b>Tightening torque, max.: 2.5 Nm!</b>	4	Centering sleeve

## 6 Start-up

### 6.1 Initial commissioning

---

#### NOTE

**To ensure fault-free operation and to minimize the radiation of electromagnetic interference (EMC) the product's housing must be properly earthed.**

---

When starting up the product for the first time, please follow the steps below:

1. Using the Ethernet/Power cable, connect the product to the existing Ethernet network or alternatively to the network card in your PC or laptop.
- 

#### NOTE

- The product's IP address is factory-set to a static value of 192.168.1.20. Should you wish to operate several products in the same network and/or if this address is already in use, then you will have to change the product's IP address accordingly (e.g. set the 2nd product's IP address to 192.168.1.21). To do that, first connect the product directly to computer's network connection, to avoid address conflicts in the network. For more information about changing the IP address: ▶ [6.2 \[□ 36\]](#)
  - To directly operate the product on your computer's network connection, you may have to alter your computer's network configuration. If in doubt, contact your system administrator.
- 

2. Connect your product with the power supply (24 V, 3 A).
  - ✓ The product will now start up. The indicator for the operating state will light up blue and after about 5 seconds it will start flashing quickly blue. This signals that the product is booting.
  - ✓ After about 15 seconds the indicator will slowly flash white. The product is ready for use
3. On your computer, open the Internet browser and enter the address <http://192.168.1.20>.
  - ✓ You will be presented with the product's configuration interface

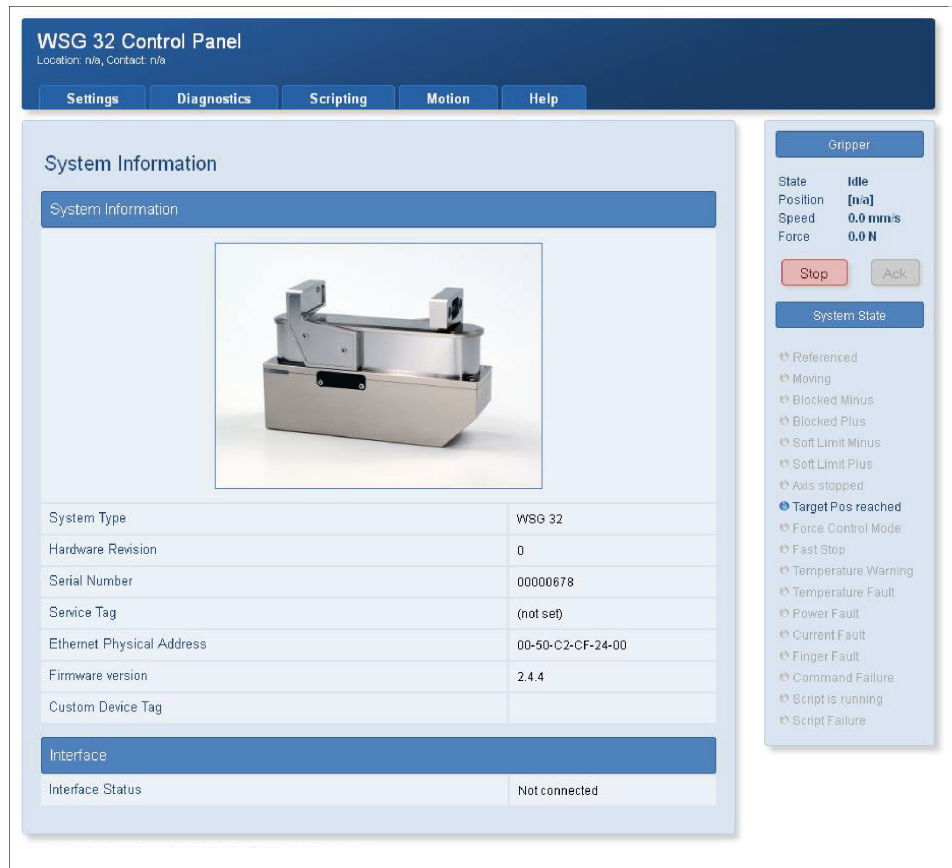

The starting page of the web-based interface

4. From the menu, select the *Motion* -> *Manual Control* option and click on the "Home" button
  - ✓ The product will now zero itself.

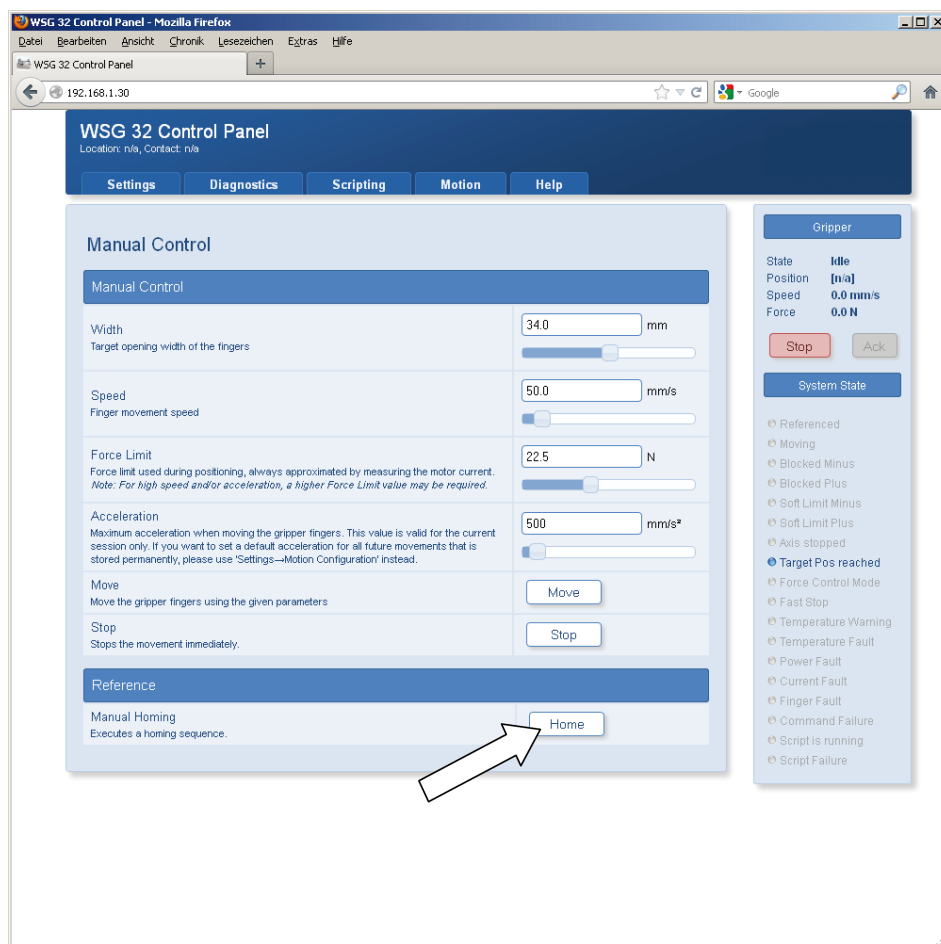

“Manual Control” configuration page

- Once the homing sequence has been finished, for test purposes, you can move the product via the web interface. For this, select the movement parameters about the adjuster and then click on the “Move” button.

**Important:** The product must have been zeroed to be able to execute movement commands.

#### Other steps which you should take during the commissioning:

- Call up the *Diagnostics* -> *System State* page, to check the product’s supply voltage.
- On the *Settings* -> *Command Interface* page, select the protocol on which your product is to be operated.
- If necessary, on the *Settings* -> *Motion Configuration* page enable automatic homing during startup („Homing on Startup“)
- On the *Settings* -> *System* page, create a user with corresponding rights and activate the web interface’s security function, to prevent changes to your setting by unauthorized persons.

## 6.2 Changing the IP address and using DHCP

To change the product's IP address, in the web interface, select the *Settings* -> *Network* option menu. Adjust the IP address, subnet masks and any gateway or DNS server addresses for your local network and confirm the changes by clicking on the "Apply" button.

---

### NOTE

**After changing the network configuration you will have to restart the product.**

---

To use addresses dynamically assigned via DHCP, check the corresponding box. In this case the product will automatically take its network configuration from a DHCP server.

---

### NOTE

**Please note that if you use DHCP to dynamically allocate IP addresses, there is no integrated way of finding out what IP address has been allocated. This is why the DHCP server should be config-ured so that the product is issued with an IP address which is known in advance**

**For further information, please contact your network administrator.**

---

## 7 Operation

The product disposes a powerful integrated control unit. The control unit is accessible by removing the cover plate with the Schunk-Logo.

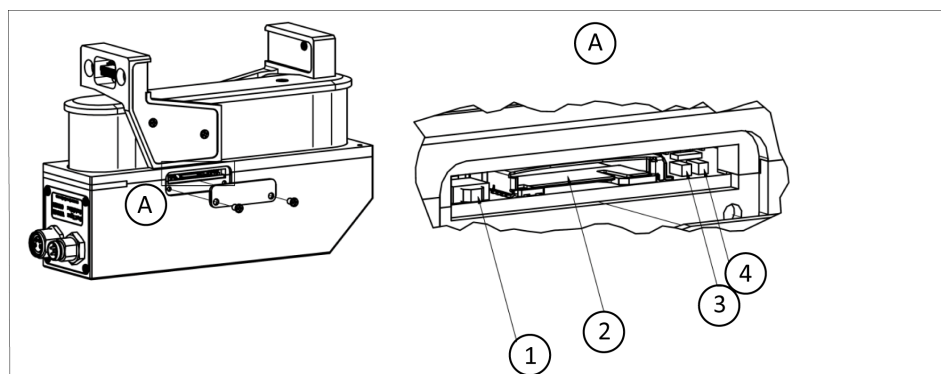

Access shaft to the control unit

1	Button: configuration-reset	2	Memory card
3	LED: Access memory card	4	LED: networkactivity

Via this tray, additional control LEDs and the memory card can be accessed.

### CAUTION

#### Material damage due to improper fastening!

The control unit can be damaged if using the wrong screws.

- Only use the supplied screws to mount the plate.

## 7.1 Operating software

The software needed to operate the product is already installed in the unit.

---

### NOTE

- To guarantee proper operation, the latest version of firmware should always be installed in the product.
  - ✓ The latest firmware can be obtained from the SCHUNK.
- 

## 7.2 Memory card

The gripper control unit has a slot to insert a MicroSD memory card. Although all common variants are supported (SD and SDHC), we recommend the use of the following memory cards:

### MicroSD card:

Made by: SANDISK, type: SDSAQM-002G-B35, capacity: 2 GB

### The memory cards hold the following data:

- Software needed to operate the product
- Configuration data
- Documentation and software tools (can be called up via the web interface)
- Scripts and other user-specific data in the /user directory

The card installed by the manufacturer has a capacity of 2 GB. The required operating software is already installed on the card. User-specific data and scripts can be saved in the "user" subdirectory. Please do not change or delete any files outside of this directory as, otherwise, fault-free operation of the product can no longer be guaranteed.

---

### NOTE

**The memory card and the software which it contains are needed to operate the product. Should you wish to replace the memory card, please copy the contents of the original card onto the new one using a suitable card reader.**

---

### **7.3 The boot process**

The product has a boot loader, which loads and runs the unit's software from the memory card when the unit is powered up. The indicator for the operating state will light up blue during this. If there is an error, the indicator will light up red for 5 seconds. After this the boot loader will automatically be restarted. This will continue until the firmware can be loaded correctly.

### 7.4 Display of operating state

The product has a multi-colored indicator for the operating state. The current operating state is shown by both the color of the indicator as well as by the flash rate.

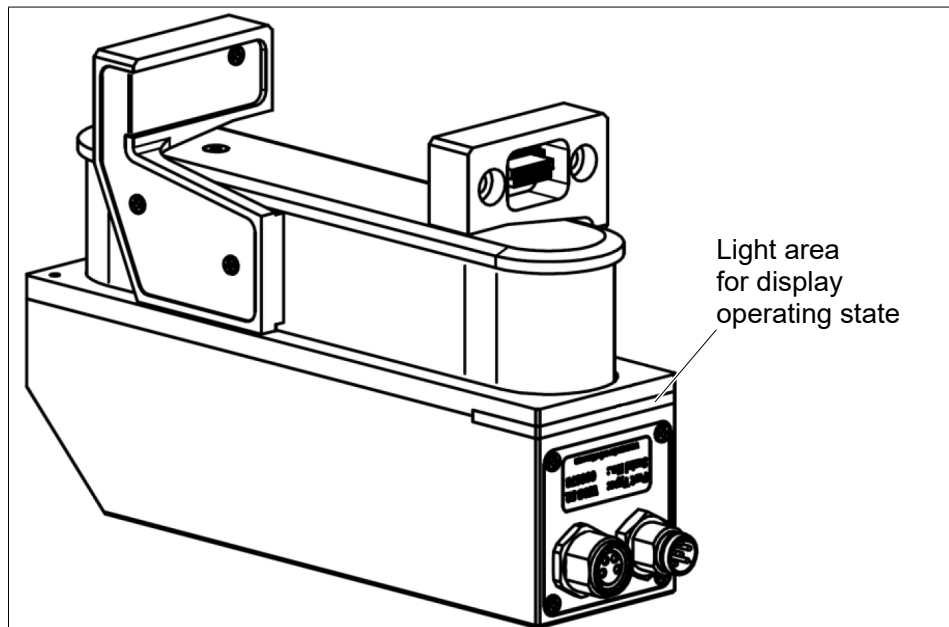

Display of operating state

The following operating states are indicated:

State	Display
<b>Loading the operating software</b> The product loads the firmware and gets ready to start.	Blue, constantly on
<b>Bootloader, interactive mode</b> The bootloader has detected a connected VT100 terminal and is operated by it (in normal operation this state does not occur).	Violet, continuously
<b>There was an error loading the operating software</b> After this the boot loader will automatically be restarted.	Red for about 5 seconds, then blue again
<b>The boot process for the operating software.</b> The operating software will be started and the control system will be configured.	Blue, flashing
<b>Wait state</b> The product is ready for operation and is waiting for a command.	White, slowly pulsating
<b>Busy</b> The product is in the initialization phase or is currently executing a command.	White, quickly pulsating
<b>Executing a script</b> A script is being executed by the control system.	Green, quickly pulsating

State	Display
<b>Warning</b> One or more parameters have reached warning limits. Please check the system's status via its web interface.	Yellow, quickly pulsating
<b>Command received with no errors</b> The product has received an error-free command.	Green, pulses once
<b>Error carrying out a command</b> An error has occurred while receiving or executing a command.	Red, pulses once
<b>Critical fault</b> An error has occurred (e.g. excess temperature, loss of communications, etc.). This error must be acknowledged before the product can process new commands to move.	Red, pulses quickly
<b>Critical software fault</b> A serious error has occurred and the execution of the software in the unit has been stopped. The product will restart after a short time.	Red, flash code 2x short, long pause

More LEDs indicating SD card and communication activity can be found next to the SD card slot under the cover plate with the SCHUNK logo.

A constant lightning of the respective LED indicates that the interface is active. The LEDs flash in the rhythm of the interface activity or data traffic.

## 7.5 Status word and gripper state

The product's current state can be called up at any time via the status word and the gripper state.

### 7.5.1 Status word

The current state of the product is summarized in the so-called status word. This can be read out via the command interface (using the command: Get System State, 40h), via the web interface or via a script (using the command: Read System State flags, gripper.state()). Following figure shows the display of the status word via the side bar in the web interface. The status word includes both pure status messages (e.g. zeroed, execution of script, etc.) as well as warnings and errors (e.g. temperature warning, power failure, etc.).

#### NOTE

You will find the documentation for the status word in the manual “WSG Command Set Reference“

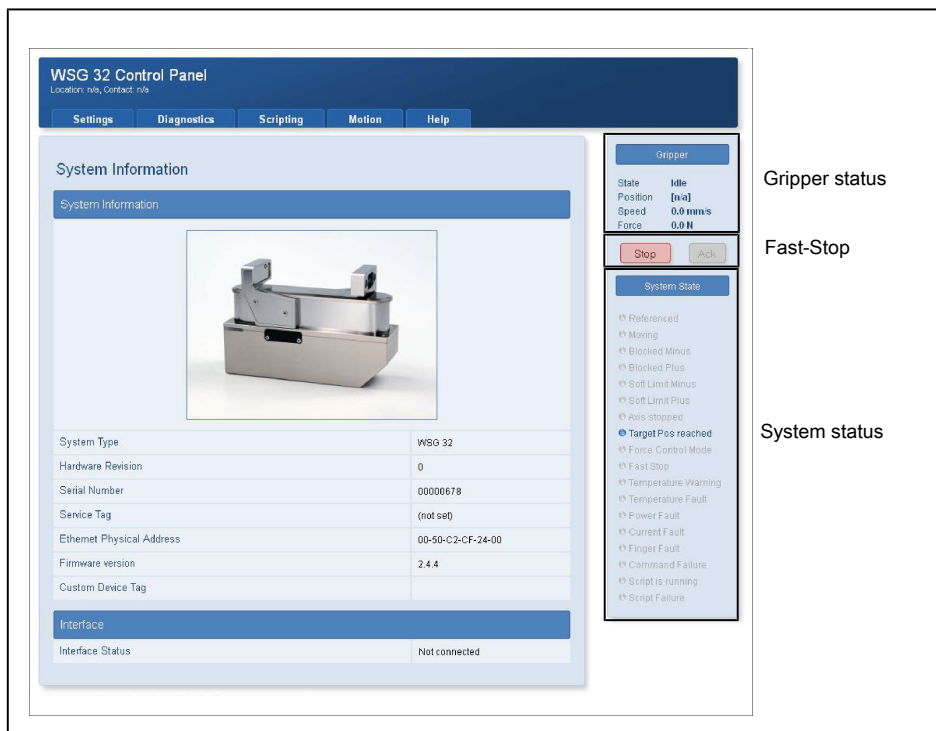

Web Interface side bar with system state

### 7.5.2 Gripper state

The gripper state reflects the current state of the gripper and is used to control the process of gripping. It can take the following states:

State	Description
IDLE	<b>The gripper is in its idle state</b> No gripping process is currently in progress
GRIPPING	<b>The gripper is closing</b> A part is being gripped, the fingers are moving towards the part. The detection of gripped items is active.
HOLDING	<b>A part is being held</b> A part is being held with the configured force. The monitoring of the gripped part has been activated.
PART LOST	<b>A part has been lost</b> The pre-configured gripping force can no longer be applied, presumably because the part to be gripped has been lost.
NO PART FOUND	<b>No part has been found</b> When closing the gripper at the configured position, no part was found to be gripped.
RELEASING	<b>The gripper is opening</b> The gripped part is being released, the fingers are moving.
POSITIONING	<b>Pre-positioning</b> The gripper is being pre-positioned and the fingers are moving.
ERROR	<b>Error</b> An error occurred carrying out the last command. For errors which require acknowledgment, the SF_FAST_STOP flag is also set in the system status word.  After any acknowledgment required, the movement can be restarted.

The gripper's state is shown like the status word in the side bar of the web interface. The following diagram shows the possible transitions between the gripper's states.

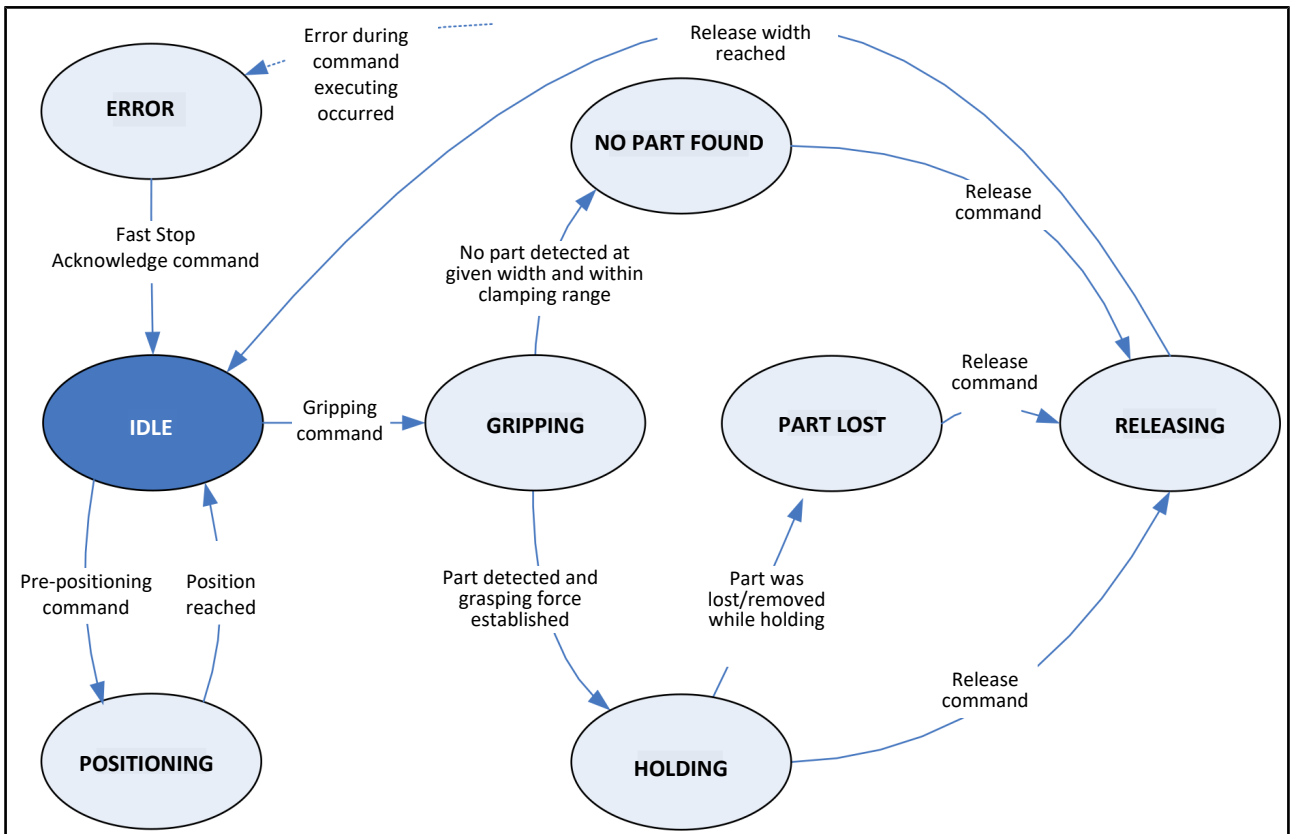

Transitions between the gripping states

**Stop command:** Issuing a Stop command in any state (except ERROR) will abort the current action and immediately return to IDLE state.

## 7.6 Homing the product

To detect the products's position, it is equipped with a measuring system which can detect the finger's spatial location at a high resolution. Due to the incremental method of position detection, the product has to be homed before motion commands can be executed.

The product has a special command for homing which can be issued via the command interface, by a script or via the web interface. It then moves its fingers to the inner or outer physical limit and saves the measured position as a reference value. To offer maximum flexibility, the product can be referenced to the inner as well as to the outer limit. For outer homing, a factory-calibrated value is used to shift the reference position, so that both variants end up with the same direction and the same origin for the axis coordinates.

---

### NOTE

- Make sure that the fingers can actually move freely in the reference drive direction up to the product's mechanical limit.
  - Due to the integrated damping elements at the outer limit, the grippers's position accuracy is better when homing to the inside.
  - To automatically execute a homing sequence on start up, activate the "Homing on Start up" option via the web interface *Settings ->Motion Configuration*
-

### 7.7 Gripping, detecting parts to be gripped and monitoring the gripping

The product is equipped with an integrated detector for parts to be gripped and a grip monitor, which allows reliable handling even for difficult parts without the use of external sensors. To configure these functions, the following parameters are available on the web interface *Settings -> Motion Configuration*:

Parameter	Description
Part Width Tolerance ("Part Width Tolerance")	The tolerance of the specified nominal gripper width which is sent to the product with the grasp command. This is measured as the relative gap between two fingers moving towards one another.
Clamping travel ("Clamping Travel")	If a part to be gripped has been detected, the product will attempt to apply the required gripping force by moving the fingers within this range. This is measured as the relative gap between two fingers moving towards one another.

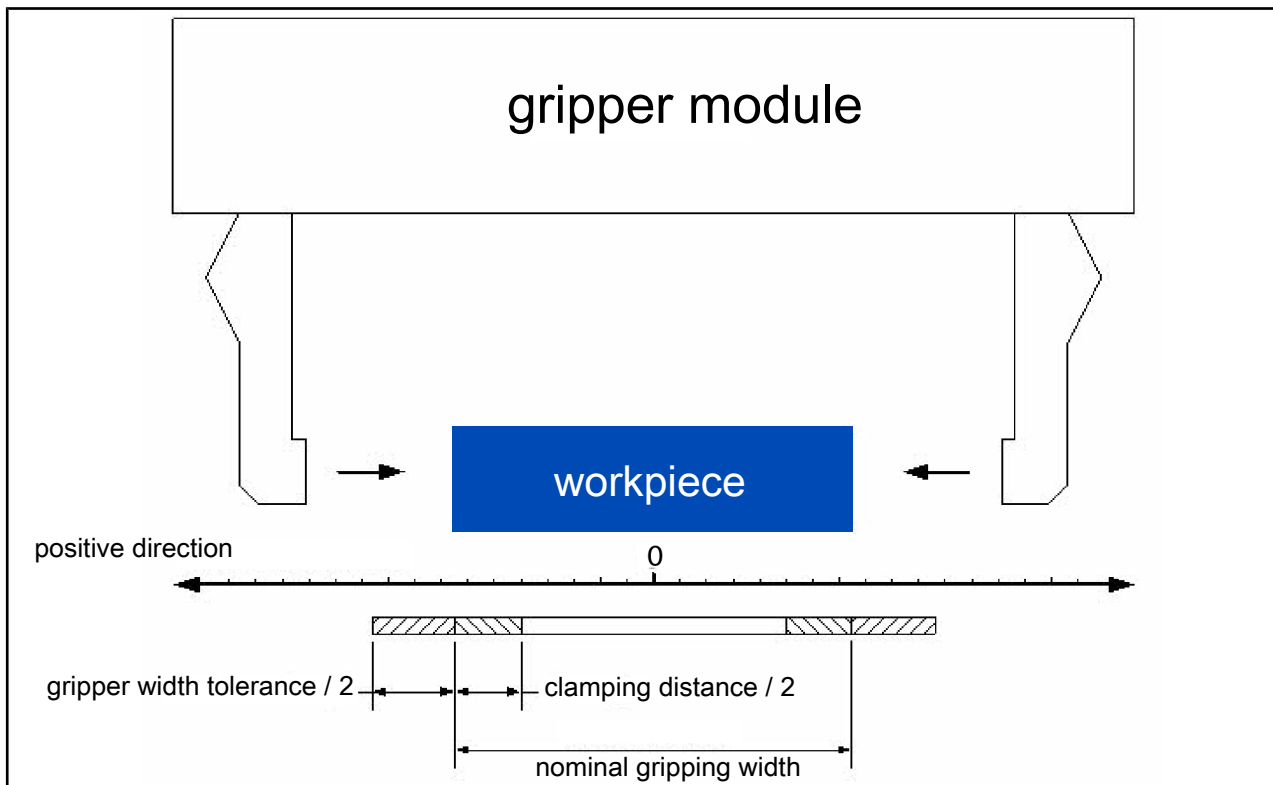

Parameters defining a grip

The figure clarifies the function of these two parameters. A grip is only valid (which means it doesn't create an error) if the detected width of the part lies within the hatched area consisting of the part width tolerance and the clamping travel. If no part is detected, then the gripper state will change to "NO PART FOUND". If a

---

contact is detected outside of the defined range, this will be detected as an axis block and the gripper's state will change to "ERROR".

---

**NOTE**

**The detector of parts to be gripped and the grip monitoring are not running in pre-position mode ("Pre-position" command).**

**CAUTION****Material damage due to insufficient lubrication!**

In the case of long-term short travel, it is possible to dry the product.

- Every 1000 movements or at least once per day the product should be moved through its full range of travel.

---

**NOTE**

- For soft parts to be gripped, it may be necessary to increase the clamping travel.
  - Setting the part width tolerance to the full range of movement of the product (maximum settings) will deactivate the detection of axis blocking when gripping.
-

## 7.8 Software limit switch

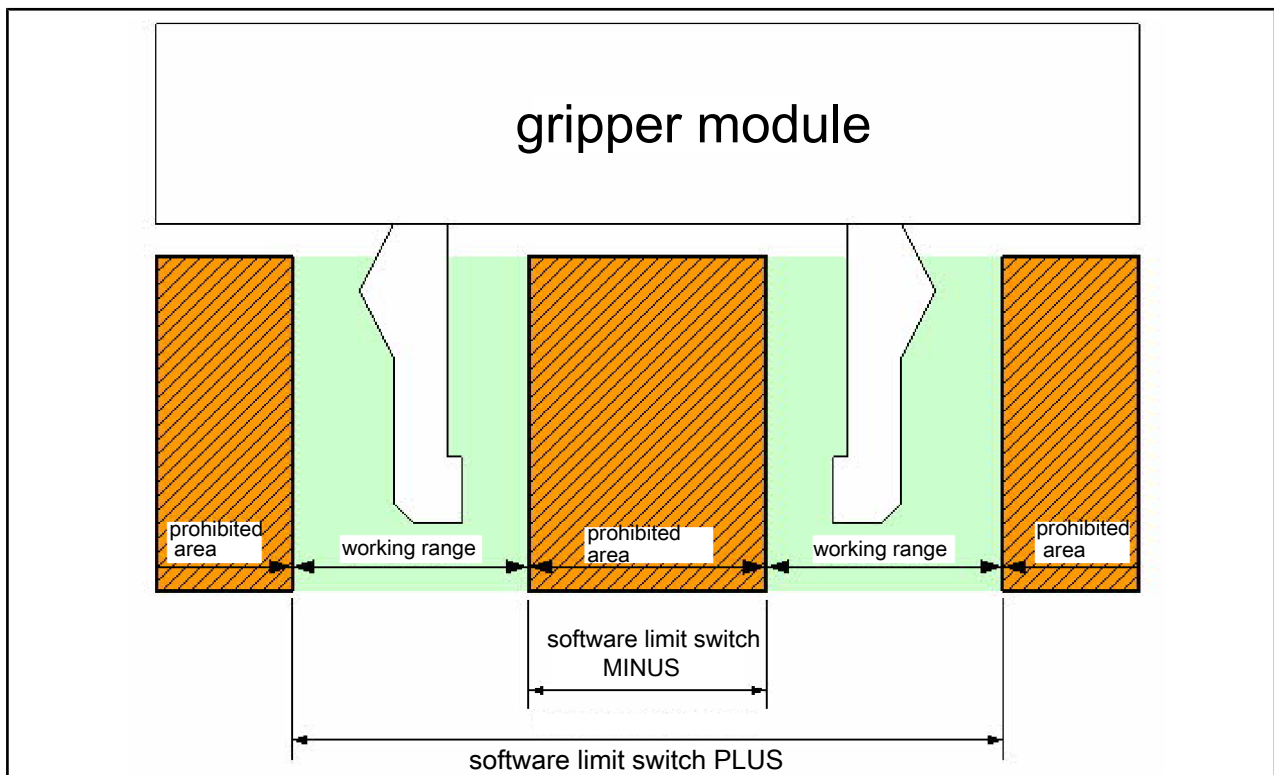

Software limit switch

The product's travel can be limited via the software limit switch. There is one limit switch for an inner range ("MINUS") and one for an outer range ("PLUS"). If the software limit switches have been activated, then positioning commands to move fingers into this range will get a range error response and the command will not be executed. There is also protection from crossing the edges of these ranges. The monitoring will trigger a fast stop which requires acknowledgment if the fingers should be moved into these areas. The software limits can be set via the command interface, a script or the web interface (*Settings -> Motion Configuration*).



### **⚠ WARNING**

**These software limits do not represent a safety function as understood by the machine directive!**

### **CAUTION**

**The software limit switches are always related to the reference position of the base jaws. Bodies on the base jaws or on the gripper jaws are not included!**

---

**NOTE**

- If the fingers are within the forbidden area when the software limit switches are activated, then only movements to leave this area will be possible.
  - More information on this subject are in the manuals "WSG Command Set Reference Manual" and "WSG Scripting Reference Manual".
- 

**7.9 Fast stops requiring acknowledgment**

The product offers a so-called Fast Stop to put the product into a defined state in case of an error or malfunction. Fast Stops are displayed by setting the SF\_FAST\_STOP flag in the status word. If a fast stop is triggered, for example due to an insufficient voltage error, then all movement commands will be rejected until the error is acknowledged and any fault condition has been cleared, with corresponding error codes being returned (access denied). If the product is in Fast Stop state, power will be removed from the drives but the position reference will be retained.

The error can be acknowledged both via the command interface (the command is: Acknowledging a Fast Stop or fault Condition, 24h) as well as manually by clicking on the "Ack" button in the side bar of the web interface ▶ 7.5.1 [□ 42].

Fast stops are recorded in the product's event log ▶ 7.10 [□ 50].

**⚠ WARNING****Loss of gripping power on fast stop!**

Workpieces can fall down and cause serious injury.

The fast stop does not represent a safety function as understood by the machine directive.

---

**NOTE**

**A fast stop can also be triggered via the command interface, by a script or manually via the web interface.**

---

**NOTE**

**More information on this subject are in the manuals "WSG Command Set Reference Manual" and "WSG Scripting Reference Manual".**

---

## 7.10 Log memory

The product has a non-volatile log memory in which important events can be recorded. The events can be saved with a timestamp and they are sorted in chronological order. If no time of day is available via the network, then the time in milliseconds since the system was started will be used. When the memory is full, the oldest events will be overwritten. The log memory can be read out via the web interface (*Diagnostics ->System State*).

For diagnostic purposes, it can also be copied to the internal SD card and can be downloaded via the file manager integrated in the web interface:

1. Open the web interface.
2. Go to *Diagnostics -> System Information*.
3. Click on the "Dump" button underneath the log.
  - ✓ A file "logfile.txt" will be created in the user directory on the SD card.
4. Download the file using the file manager. To do that, select "File Manager" in the in the menu "Scripting". Click on the file and start the download via the button. 

## 7.11 Thermal monitoring

To protect the product from overheating, its housing is constantly monitored during operation. The current housing temperature can be checked both via the web interface as well as the command interface.

If the temperature measured exceeds the limit of 65 °C, then a temperature warning will be issued. From a housing temperature of 70 °C the product will change into temperature error mode and will switch the power output stage off via a fast stop. This temperature error must be acknowledged via the "Fast Stop Acknowledge" command.

Temperature warnings and errors are recorded in the product's event log memory ▶ 7.10 [□ 50].



### **⚠ WARNING**

#### **Loss of gripping force on temperature error!**

Workpieces can fall down and cause serious injury.

### **NOTE**

- This error can only be acknowledged if there is no longer a temperature error.
- The command to read out the current housing temperature and the command to acknowledge the Fast Stop via the command interface are documented in the "WSG Command Set Reference Manual".

## 7.12 Monitoring the motor current

The drive current is continuously measured and monitored during operation. An integrated motor model is used to check whether the drive is being overloaded or not. In this case, the power output stage will be switched off via a fast stop and a "current fault" will be displayed. The current error must be acknowledged. This can either be done via the web interface or via the command interface using the "Fast Stop Acknowledge" command. Current errors are recorded in the product's event log ▶ 7.10 [📄 50].



### **⚠ WARNING**

#### **Loss of gripping force when there is a current error!**

Workpieces can fall down and cause serious injury.

---

### **NOTE**

- This error can only be acknowledged if there is no longer a current error.
  - For the documentation of the command to acknowledge the "Fast Stop" via the command inter-face, see the "WSG Command Set Reference Manual".
-

### 7.13 Monitoring the supply voltage

To ensure the correct functioning of the product, the supply voltage to its power section is continuously monitored. If this is outside a defined range, a warning or an error will be issued. The following limits apply:

Threshold	Consequence
$V_{\text{DRIVE}} \leq 20 \text{ V}$	<b>Low voltage fault</b> SF_POWER_FAULT will be set in the system's status word and the status indicator will show the error state.
$V_{\text{DRIVE}} \leq 22 \text{ V}$	<b>Low voltage warning</b> SF_POWER_WARNING will be set in the system's status word and the status indicator will show the warning state.
$V_{\text{DRIVE}} \geq 26 \text{ V}$	<b>Excess voltage warning</b> SF_POWER_WARNING will be set in the system's status word and the status indicator will show the warning state.
$V_{\text{DRIVE}} \geq 28 \text{ V}$	<b>Excess voltage error</b> SF_POWER_FAULT will be set in the system's status word and the status indicator will show the error state.

Hysteresis is used to prevent the states chattering to and fro. If there is a voltage error, the power output stage will be switched off using a fast stop and a voltage error will be indicated. This must be acknowledged, but will only be possible when the operating voltage is back in its permissible range. You can do this either via the web interface or via the command interface via the "Fast Stop Acknowledge" command.



#### **⚠ WARNING**

**Loss of gripper power following an error due to the voltage being too high or too low!**

Workpieces can fall down and cause serious injury.

#### **NOTE**

- The low voltage fault will also be triggered if the power supply is interrupted when switching the force off, e.g. via an emergency stop relay.
- This error can only be acknowledged when there is no longer a high/low voltage error.
- Further information of the system status word and of the command to acknowledge the "Fast Stop" via the command interface, see the "WSG Command Set Reference Manual".

## 7.14 Configuration and diagnosis via the web interface

The product has an integrated web server, with an user interface for configuration and diagnosis. To use this, the product must be connected via Ethernet. To get to the configuration user interface, open a browser and enter the product's IP address (on delivery this is 192.168.1.20) into the browser's address line:

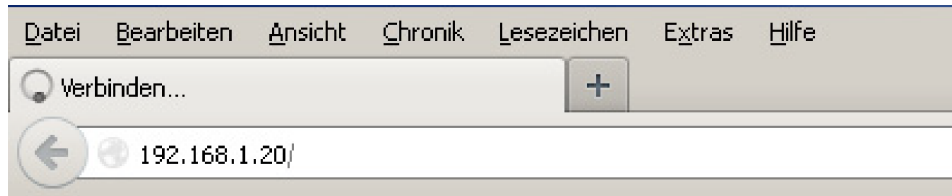

*Entering the IP address to start web-based configuration*

The following browsers have been tested and support the product's web interface:

- Mozilla Firefox 16 and above
- Google Chrome 23 and above
- Apple Safari 5 and above
- Mobile Safari (iOS 4.3 and above)
- Internet Explorer 8 and above

---

### NOTE

**To display the web user interface, JavaScript must be enabled in your browser.**

---

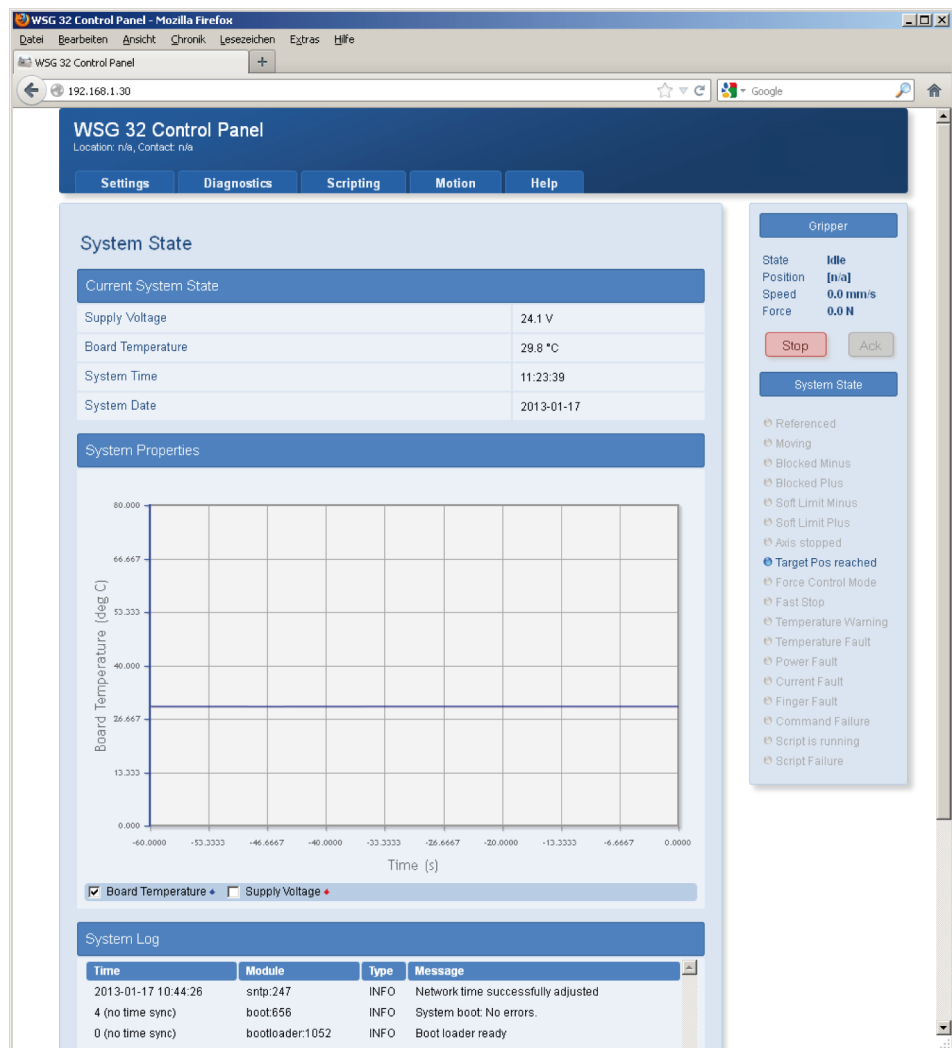

Web interface for configuration and diagnosis

Via integrated help texts, the product's web interface is intuitive to use. In the upper area you will find a menu bar via which the individual pages can be called up.

### 7.14.1 Access restrictions for the web user interface

Depending on the network configuration, the product will be visible to everyone in the entire network and the configuration can thus be altered unchecked.

To restrict access to the product's web interface, under *Settings* -> *System Configuration* you can activate access restrictions for the interface and create users with differing access rights.

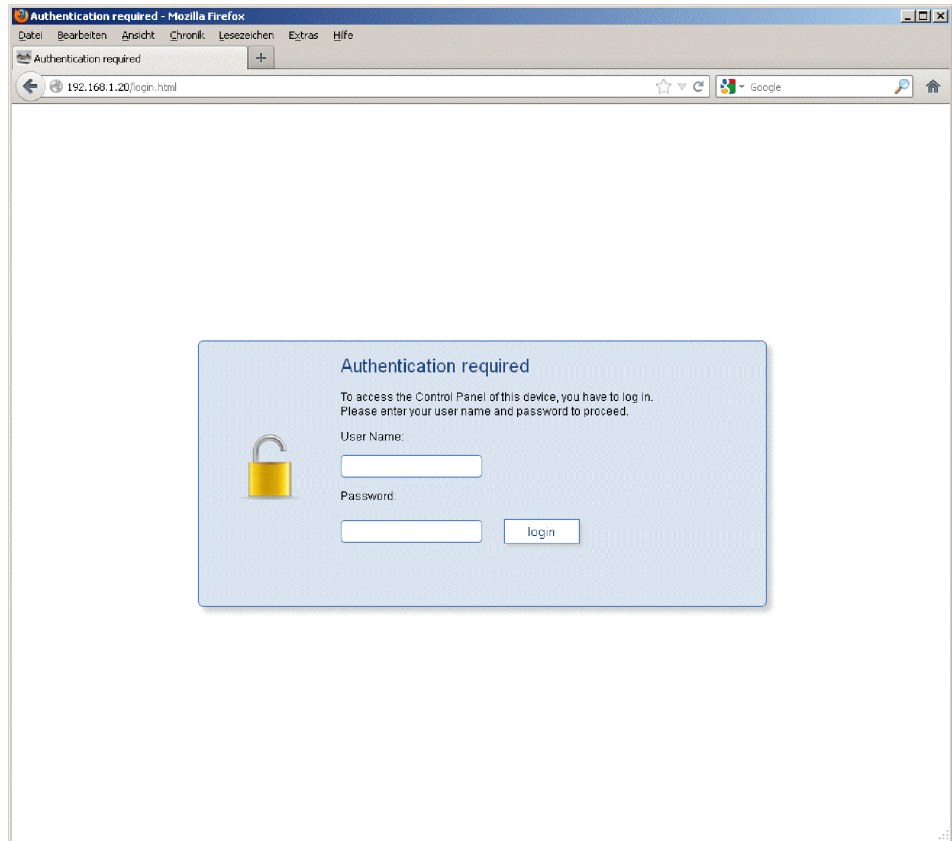

Login screen

If this is activated, each user must be identified with a login name and personal password.

Every user is assigned to one of the following user groups:

- **User**  
Standard user: Cannot adjust settings, but can only access the pages under the menu options “Diagnostics” and “Help”.
- **Administrator**  
Administrator: Can adjust all of the product’s settings without restriction.

#### NOTE

**If access restrictions have been activated, then the product will record which user logs in and when.**

## 7.15 Command interface

The product supports the control system via TCP/IP, UDP, PROFINET (optional) and Modbus/TCP.

TCP/IP and UDP can be used to communicate with a text-based communication protocol (Gripper Command Language - GCL), which is specified in the document "WSG GCL Reference Manual". It is also possible to communicate via TCP/IP and UDP using a binary communication protocol. The binary communication protocol is described in detail in the document "WSG Command Set Reference".

For control via the PROFINET and Modbus/TCP fieldbus interfaces, a DPv0-compatible input/output area is available, which can be used to control the product by setting discrete values and to read the current product parameters. For details, refer to the document "WSG Fieldbus Interface Documentation".

The command interface is selected and configured via the product's web interface, via the menu option *Settings* -> *Command Interface*.

## 7.16 Scripting

The product includes an integrated interpreter for the Lua programming language, via which you can adapt the product's software to your application. The programs (scripts) are saved on the integrated memory card and can be run automatically when the product starts. The interpreter is configured via the web interface. You will find the reference information for the commands as well as notes about creating and using scripts in the document "WSG Scripting Reference Manual".

## 7.17 Resetting the configuration

Via the page "*Settings -> System*", the product's configuration can be reset to its state on delivery. Should the configuration interface no longer be accessible, for example if the network configuration is faulty, or if you have forgotten your password, the product can also be reset using a button in the tray under the cover plate see Figure "Access shaft for gripper control", ▶ 7 [□ 37].

To reset the module, follow these steps:

1. Remove the cover plate from the control tray
2. Press the configuration reset button.
  - ✓ The SD card's access LED will start to blink.
3. Keep the button pressed until the module restarts after about 5 seconds.
  - ✓ The configuration has been reset to factory defaults.

## 7.18 Implementing the gripping process

In the following section, the steps are described which are needed for a simple handling cycle (preposition - grip - release). The specified commands relate to the command interface. You will find a detailed description of the commands and parameters in the "WSG Command Set Reference Manual".

### Preparatory work:

1. **Adjust the "Clamping Travel" and "Part Width Tolerance" to the application.**  
Description: ▶ 7.7 [□ 46]
2. **Perform a test grip.**  
You can do this for example via the web interface, menu option *Motion -> Grasping*

### Executing the gripping cycle:

1. **Check whether the gripper has been zeroed (optional)**  
If not, run the command "Homing (20h)" and wait until SF\_REFERENCED is set in the status word. Request the status word with the command "Get System State (40h)". Error? then error handling.
2. **Pre-position finger**  
Execute the command "Pre-Position Fingers (21h)".  
Parameters: Opening width and speed. The gripper state changes to "POSITIONING". Wait until the gripper state is "IDLE". Request the gripper state with the command "Get Gripping State (41h)".

**3. Execute the grip**

Command "Grasp Part (25h)". Parameters: Nominal gripping width, gripping speed, gripping force. The gripper state changes to "GRIPPING". Wait until the gripper state is "HOLDING". Deal with errors if gripper state is "NO PART FOUND" or "ERROR".

**4. Handling the part**

Periodically request the gripper state and check whether it is still "HOLDING". Deal with errors for "PART LOST" or "ERROR". The periodical requests will not be required if spontaneous messages (see "WSG Command Set Reference Manual") have been activated.

**5. Releasing the part**

Command "Release Part (26h)". Parameters: Opening width, speed. The gripper state changes to "RELEASING". Wait until the gripper state is "IDLE". Deal with errors on "ERROR".

**6. Start again at 2.****Dealing with errors**

What to do in case of an error actually depends a lot on the application, but in general requires the user to do something. The following section gives some hints:

**1. Does the returned status code differ from E\_SUCCESS?**

Evaluate the returned status code and eventually request user intervention.

**2. Gripper status „ERROR“**

Request user intervention. Also: Test whether SF\_FAST\_STOP is set in the status word. If it is, then request acknowledgment.

**3. Gripper status „NO PART FOUND“**

Depending on the task, jump over the processing and fetch a new part.

**4. Gripper status „PART LOST“**

Part lost. If necessary, abort processing and fetch new part or request user intervention.

**NOTE**

- For the implementation of gripping processes via PROFINET and Modbus / TCP see instructions "WSG Documentation of fieldbus interface".
- Gripper cycles can also be mapped via a script. For this purpose, please see the "WSG Scripting Reference Manual".

**CAUTION****Material damage due to insufficient lubrication!**

In the case of long-term short travel, it is possible to dry the product.

- Every 1000 movements or at least once per day the product should be moved through its full range of travel.

## 8 Maintenance and cleaning

The maintenance and lubrication intervals must be adapted to the ambient and operating conditions. The following factors should be taken into account here:

- Extreme operating temperatures
- The effects of condensation
- High vibration loading
- Use in a vacuum
- Very dynamic operation
- The effect of foreign substances (e.g. steam, acids, etc.)

Clean the product at regular intervals with a dry cloth to remove all soiling and metal chips. These typically collect in the depressions, on the rail channel of the cover or and on the edges of the housing.

### **CAUTION**

#### **Material damage due to insufficient lubrication!**

In the case of long-term short travel, it is possible to dry the product.

- Every 1000 movements or at least once per day the product should be moved through its full range of travel.
-

## 9 Troubleshooting

### 9.1 The gripper jaws don't move

Possible cause	Corrective action
Base jaws jam in housing, e.g. mounting surface is not sufficiently even.	Check the evenness of the mounting surface.
	Loosen the mounting screws of the product and actuate the product again.
A component is broken e.g. due to overloading.	Replace component or send it to SCHUNK for repair.
	Make sure that the product was only used in the context of its defined application parameters.
Operating voltage is not sufficient.	Check the power supply.
	Check requirements on power supply.
Communication not possible.	Check the connections and communications cables.
	interface addressing. Check (e.g. IP address)
	Check the connection parameters.
Error message in the system (LEDs on the product are lamping yellow or red).	Check operating state of the product.

Possible cause	Corrective action
Base jaws jam in housing, e.g. mounting surface is not sufficiently even.	Check the evenness of the mounting surface.
	Loosen the mounting screws of the product and actuate the product again.
A component is broken e.g. due to overloading.	Replace component or send it to SCHUNK for repair.
	Make sure that the product was only used in the context of its defined application parameters.
Operating voltage is not sufficient.	Check the power supply.
	Check requirements on power supply.
Communication not possible.	Check the connections and communications cables.
	Check interface addressing. (e.g. IP address and Port settings).
	Check the connection parameters.
Error message in the system (LEDs on the product are lamping yellow or red).	Check operating state of the product.

### 9.2 Gripper stops abruptly

Possible cause	Corrective action
Supply voltage is not connected.	Check the power supply.
Communication not possible.	Check the connections and communications cables.
<b>Fast stop</b>	Check the status of the gripper control system.
	Determine the cause of the fast stop and remedy if necessary.
	Acknowledge the fast stop, Fast stops requiring acknowledgment
<b>Error message in the system (the operating state indicators of the product illuminate yellow or red)</b>	Check operating state of the product.

### 9.3 No connection to the web interface

Possible cause	Corrective action
Supply voltage is not connected.	Check the power supply.
Communication not possible.	Check the connections and communications cables.
	Check network settings on the product.
	Check network settings on the computer.



## 11 Annex to Declaration of Incorporation

according 2006/42/EG, Annex II, No. 1 B

1. Description of the essential health and safety requirements pursuant to 2006/42/EC, Annex I that are applicable and that have been fulfilled with:

Product designation	Servo-electric 2-finger parallel gripper
Type designation	WSG 32
ID number	0306130

To be provided by the System Integrator for the overall machine	↓
Fulfilled for the scope of the partly completed machine	↓
Not relevant	↓

1.1	Essential Requirements		
1.1.1	Definitions	X	
1.1.2	Principles of safety integration	X	
1.1.3	Materials and products	X	
1.1.4	Lighting	X	
1.1.5	Design of machinery to facilitate its handling	X	
1.1.6	Ergonomics	X	
1.1.7	Operating positions		X
1.1.8	Seating		X

1.2	Control Systems		
1.2.1	Safety and reliability of control systems	X	
1.2.2	Control devices	X	
1.2.3	Starting	X	
1.2.4	Stopping	X	
1.2.4.1	Normal stop	X	
1.2.4.2	Operational stop	X	
1.2.4.3	Emergency stop	X	
1.2.4.4	Assembly of machinery	X	
1.2.5	Selection of control or operating modes	X	
1.2.6	Failure of the power supply		X

1.3	Protection against mechanical hazards		
1.3.1	Risk of loss of stability		X
1.3.2	Risk of break-up during operation		X
1.3.3	Risks due to falling or ejected objects		X
1.3.4	Risks due to surfaces, edges or angles	X	
1.3.5	Risks related to combined machinery		X

<b>1.3</b>	<b>Protection against mechanical hazards</b>			
1.3.6	Risks related to variations in operating conditions			X
1.3.7	Risks related to moving parts		X	
1.3.8	Choice of protection against risks arising from moving parts			X
1.3.8.1	Moving transmission parts		X	
1.3.8.2	Moving parts involved in the process			X
1.3.9	Risks of uncontrolled movements			X
<b>1.4</b>	<b>Required characteristics of guards and protective devices</b>			
1.4.1	General requirements			X
1.4.2	Special requirements for guards			X
1.4.2.1	Fixed guards			X
1.4.2.2	Interlocking movable guards			X
1.4.2.3	Adjustable guards restricting access			X
1.4.3	Special requirements for protective devices			X
<b>1.5</b>	<b>Risks due to other hazards</b>			
1.5.1	Electricity supply		X	
1.5.2	Static electricity		X	
1.5.3	Energy supply other than electricity		X	
1.5.4	Errors of fitting		X	
1.5.5	Extreme temperatures			X
1.5.6	Fire			X
1.5.7	Explosion			X
1.5.8	Noise			X
1.5.9	Vibrations			X
1.5.10	Radiation	X		
1.5.11	External radiation	X		
1.5.12	Laser radiation	X		
1.5.13	Emissions of hazardous materials and substances			X
1.5.14	Risk of being trapped in a machine	X		
1.5.15	Risk of slipping, tripping or falling	X		
1.5.16	Lightning			X
<b>1.6</b>	<b>Maintenance</b>			
1.6.1	Machinery maintenance		X	
1.6.2	Access to operating positions and servicing points		X	
1.6.3	Isolation of energy sources		X	
1.6.4	Operator intervention		X	
1.6.5	Cleaning of internal parts		X	

<b>1.7</b>	<b>Information</b>			
1.7.1	Information and warnings on the machinery		X	
1.7.1.1	Information and information devices		X	
1.7.1.2	Warning devices		X	
1.7.2	Warning of residual risks		X	
1.7.3	Marking of machinery	X		
1.7.4	Instructions	X		
1.7.4.1	General principles for the drafting of instructions	X		
1.7.4.2	Contents of the instructions	X		
1.7.4.3	Sales literature	X		

	<b>The classification from Annex 1 is to be supplemented from here forward.</b>			
2	Supplementary essential health and safety requirements for certain categories of machinery			X
2.1	Foodstuffs machinery and machinery for cosmetics or pharmaceutical products			X
2.2	Portable hand-held and/or guided machinery			X
2.2.1	Portable fixing and other impact machinery			X
2.3	Machinery for working wood and material with similar physical characteristics			X
3	Supplementary essential health and safety requirements to offset hazards due to the mobility of machinery		X	
4	Supplementary essential health and safety requirements to offset hazards due to lifting operations		X	
5	Supplementary essential health and safety requirements for machinery intended for underground work			X
6	Supplementary essential health and safety requirements for machinery presenting particular hazards due to the lifting of persons		X	

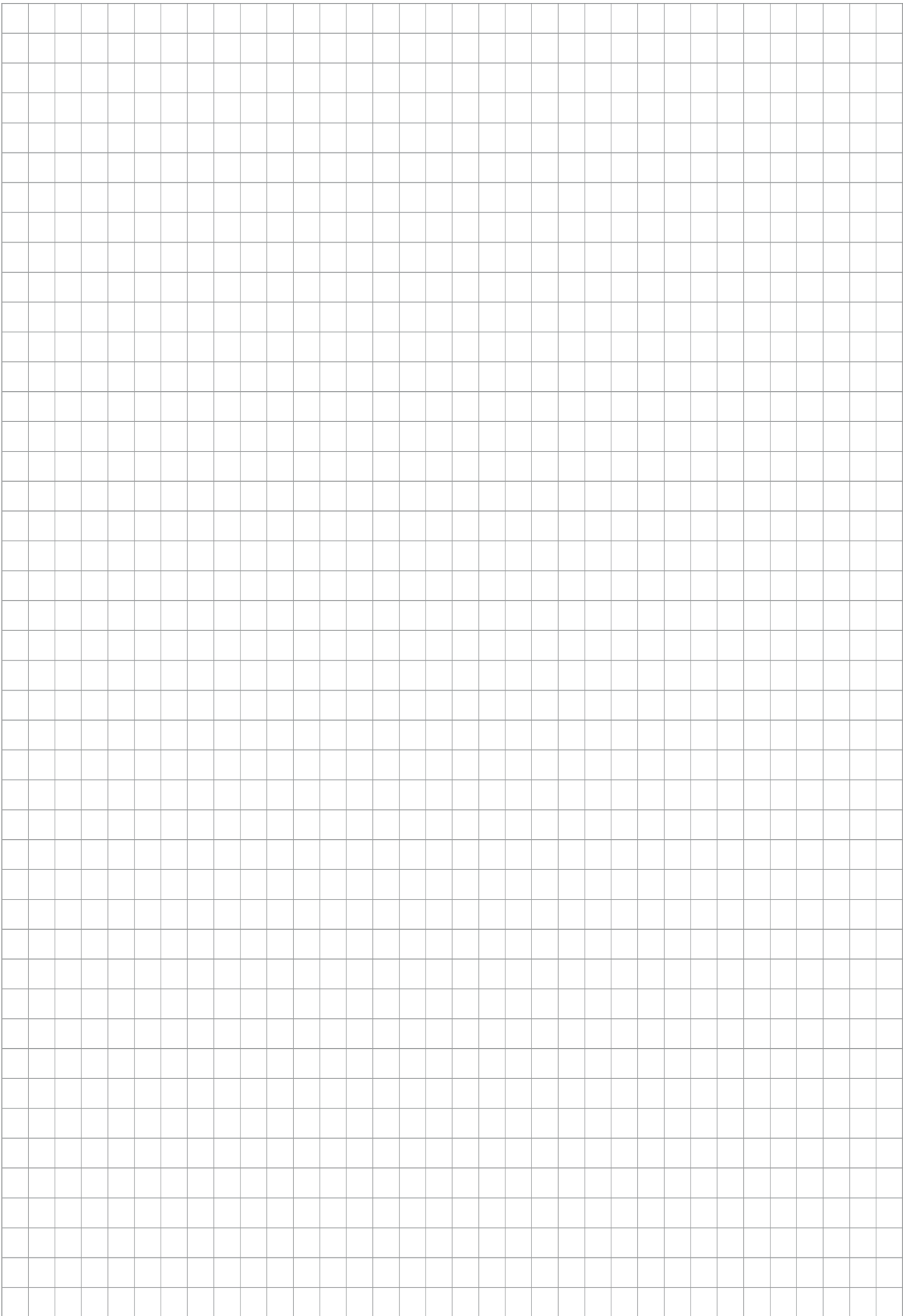

**SCHUNK GmbH & Co. KG**  
**Clamping and gripping technology**

Bahnhofstr. 106 - 134  
D-74348 Lauffen/Neckar  
Tel. +49-7133-103-0  
Fax +49-7133-103-2399  
info@de.schunk.com  
schunk.com

Folgen Sie uns | *Follow us*

