

Assembly and Operating Manual

Clamping Device SVP-2

Polygonal Clamping System

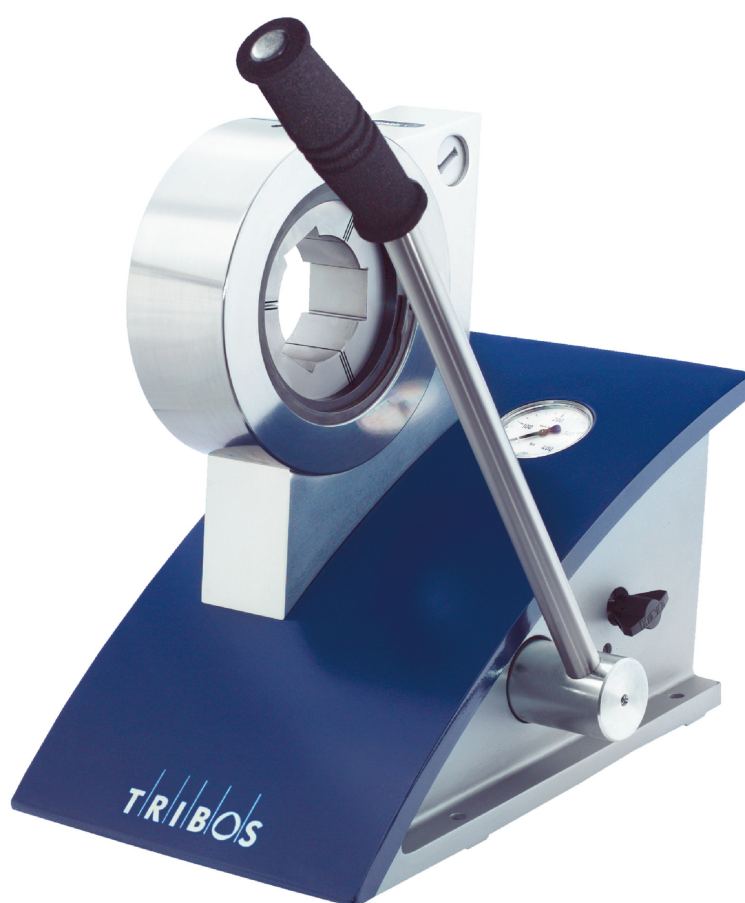

Imprint

Copyright:

This manual is protected by copyright. The author is SCHUNK GmbH & Co. KG. All rights reserved. Any reproduction, processing, distribution (making available to third parties), translation or other usage - even excerpts - of the manual is especially prohibited and requires our written approval.

Technical changes:

We reserve the right to make alterations for the purpose of technical improvement.

Document number: 0289021

Version: 03.00 | 18/02/2020 | en

© SCHUNK GmbH & Co. KG

All rights reserved.

Dear Customer,

thank you for trusting our products and our family-owned company, the leading technology supplier of robots and production machines.

Our team is always available to answer any questions on this product and other solutions. Ask us questions and challenge us. We will find a solution!

Best regards,

Your SCHUNK team

SCHUNK GmbH & Co. KG
Spann- und Greiftechnik

Bahnhofstr. 106 – 134
D-74348 Lauffen/Neckar

Tel. +49-7133-103-0

Fax +49-7133-103-2399

info@de.schunk.com

schunk.com

Table of Contents

1	General	5
1.1	About this manual	5
1.1.1	Presentation of Warning Labels	5
1.1.2	Applicable documents	6
1.2	Warranty	6
1.3	Scope of delivery	6
1.4	Accessories	6
2	Basic safety notes	7
2.1	Intended use.....	7
2.2	Not intended use.....	7
2.3	Constructional changes	7
2.4	Spare parts	7
2.5	Environmental and operating conditions	8
2.6	Personnel qualification.....	8
2.7	Transport.....	8
2.8	Disposal	8
2.9	Fundamental dangers.....	9
2.9.1	Protection during handling and assembly	9
2.10	Notes on particular risks.....	9
3	Technical data	11
3.1	Basic data	11
3.2	Position of the type plate	11
3.3	Content of the type plate	11
4	Design and description	12
4.1	Design	12
4.2	Description	12
5	Assembly and settings	13
5.1	Fastening the clamping device onto a work bench	13
5.2	Assembly of the length adjustment.....	13
6	Operation	15
6.1	Reduction insert and toolholder.....	15
6.2	Notes on clamping and unclamping	17
6.3	TRIBOS pressure table	19

7	Troubleshooting	20
7.1	Tool shank cannot be inserted if pressure is built up.....	20
7.2	Tool shank can only be partially inserted into the toolholder.....	22
7.3	Tool cannot be removed from the toolholder.....	23
7.4	Tool shank can be inserted outside the pressure range if slight pressure is applied.....	24
7.5	Tool shank can yet not be inserted at maximum pressure	24
7.6	Clamping device does not build up pressure.....	24
7.7	Torque / clamping force / holding force too low	25
7.8	Concentricity errors on the clamped tool	26
7.9	SVP-2 clamping device does not reach required pressure	27
7.10	Oil leaking out of the clamping device	28
8	Maintenance	29
8.1	Care and storage	29
8.2	Maintenance and service	29
9	Transport and disposal.....	30
9.1	Transport.....	30
9.2	Disposal	30
10	Short manual	31

1 General

1.1 About this manual

This manual contains important information for a safe and appropriate use of the product.

This manual is an integral part of the product and must be kept accessible for the personnel at all times.

Before starting work, the personnel must have read and understood this operating manual. Prerequisite for safe working is the observance of all safety instructions in this manual.

Illustrations in this manual are provided for basic understanding and may differ from the actual product design.

In addition to these instructions, the documents listed under [Applicable documents](#) [► 6] are applicable.

1.1.1 Presentation of Warning Labels

To make risks clear, the following signal words and symbols are used for safety notes.



⚠ DANGER

Danger for persons!

Non-observance will inevitably cause irreversible injury or death.



⚠ WARNING

Dangers for persons!

Non-observance can lead to irreversible injury and even death.



⚠ CAUTION

Dangers for persons!

Non-observance can cause minor injuries.

CAUTION

Material damage!

Information about avoiding material damage.

1.1.2 Applicable documents

- General terms of business *
- Catalog data sheet of the purchased product *
- Assembly and Operating manual "TRIBOS Polygonal Clamping device" (Toolholder) *

The documents marked with an asterisk (*) can be downloaded on our homepage **schunk.com**

1.2 Warranty

If the product is used as intended, the warranty is valid for 24 months from the ex-works delivery date under the following conditions:

- Intended use in 1-shift operation
- Recommended operating and maintenance regulations

Basically tool and machine contacting components, and wear parts (actuation screw and seal) are not part of the warranty.

1.3 Scope of delivery

The scope of delivery includes:

- TRIBOS clamping device SVP-2 Id No.: 0211760
- Documentation SVP-2 Id No.: 0289021

1.4 Accessories

- Cylindrical brush
(see catalog Toolholder systems "Accessories")
- Insert SRE (see catalog Toolholder systems "Accessories")
- Protective cover for TRIBOS clamping device SVP-2/2D
(ID number: 9935548)
- Length adjustment LMG-M (ID number: 0201961)
- Stacker (ID number: 0211768)
- Protective cover for Stacker (ID number: 9937963)

2 Basic safety notes

2.1 Intended use

The clamping device has been designed to equip and replace tools in TRIBOS toolholders.

TRIBOS toolholders are suitable to clamp rotationally symmetric tools or work pieces. With shank tools, all shanks can be clamped according to DIN 1835 Form A, B, E or DIN 6535 Form HA, HB, HE (shank tolerance h6).

The polygon clamping system (clamping device, reduction inserts and TRIBOS toolholders) may only be used within the framework of its defined application parameters [Technical data](#) [► 11].

- The product is intended for industrial and industry-oriented use.
- Appropriate use of the product includes compliance with all instructions in this manual.

2.2 Not intended use

It is an not intended use of the clamping device if toolholders were used that are not SCHUNK TRIBOS toolholders.

2.3 Constructional changes

Implementation of structural changes

By conversions, changes, and reworking, e.g. additional threads, holes, or safety devices can impair the functioning or safety of the product or damage it.

- Structural changes should only be made with the written approval of SCHUNK.

2.4 Spare parts

Use of unauthorized spare parts

Using unauthorized spare parts can endanger personnel and damage the product or cause it to malfunction.

- Use only original spare parts or spares authorized by SCHUNK.

2.5 Environmental and operating conditions

The TRIBOS clamping device may be stored and operated only in clean, dust-free and dry rooms at a temperature of + 15°C till + 40°C. The relative humidity can be between 20 - 80%.

2.6 Personnel qualification

The initial commissioning, maintenance, and repair of the clamping device may only be performed by trained specialist personnel. Every person called upon by the operator to work on the clamping device must have read and understood the complete assembly and operating manual, especially the chapter "Basic safety notes" [Basic safety notes](#) [► 7]. This applies particularly to personnel only used occasionally at the TRIBOS clamping device.

2.7 Transport

Handling during transport

Incorrect handling during transport may impair the product's safety and cause serious injuries and considerable material damage.

- When handling heavy weights, use lifting equipment to lift the product and transport it by appropriate means.
- Secure the product against falling during transportation and handling.
- Stand clear of suspended loads.

2.8 Disposal

Handling of disposal

The incorrect handling of disposal may impair the product's safety and cause serious injuries as well as considerable material and environmental harm.

- Follow local regulations on dispatching product components for recycling or proper disposal.

2.9 Fundamental dangers

2.9.1 Protection during handling and assembly

Incorrect handling and assembly

Incorrect handling and assembly may impair the product's safety and cause serious injuries and considerable material damage.

- Have all work carried out by appropriately qualified personnel.
- For all work, secure the product against accidental operation.
- Observe the relevant accident prevention rules.
- Use suitable assembly and transport equipment and take precautions to prevent jamming and crushing.

Incorrect lifting of loads

Falling loads may cause serious injuries and even death.

- Stand clear of suspended loads and do not step into their swiveling range.
- Never move loads without supervision.
- Do not leave suspended loads unattended.

2.10 Notes on particular risks



⚠ WARNING

Risk of injury due to lateral under high pressure escaping oil!

Lateral under high pressure escaping oil on seals or by opening the vent screw can cause serious injuries.

- Wear protective gloves and safety goggles.

CAUTION

Material damage due to incorrect insertion of the toolholder / reduction insert!

The gripping force of the TRIBOS clamping device SVP-2 goes up to 800 000 N!

Incorrect insertion and positioning of the toolholder causes plastically deformation and loss of function of the toolholder.

- Insert the toolholder till the stop into the reduction insert and position correctly (via the flattened areas).
- Insert the reduction insert till the stop into the clamping device.

CAUTION

Material damage due to wear of the reduction insert.

Too high wear of the reduction insert causes loss of function of the toolholder.

The wear of the reduction insert may be maximum of 0.04 mm.

- When exceeding the maximum wear replace reduction insert.
-

CAUTION

Material damage due to exceeding the permissible pressure!

Too high pressure causes deformation of the toolholder and loss of function.

- Observe the pressure specifications of the toolholder.
-

CAUTION

Material damage due to false minimum clamping depth!

A too low minimum clamping depth causes loss of accuracy and torque at the toolholder.

- Observe minimum clamping depth of the tool,
✓ See Assembly and Operating manual Toolholder.
-

3 Technical data

3.1 Basic data

Reference value	Value
Operating pressure [bar]	0 - 400
Pressing time (depending on clamping pressure and oil temperature)	approx. 8 sec at 400 bar
Hydraulic oil	Mobile Vactra 2 (Viskosity 68)
Ambient temperature [°C]	+15 to +40
Dimensions (L x W x H) [mm]	300 x 370 x 347
Weight [kg]	37
Protection class IP	40

3.2 Position of the type plate

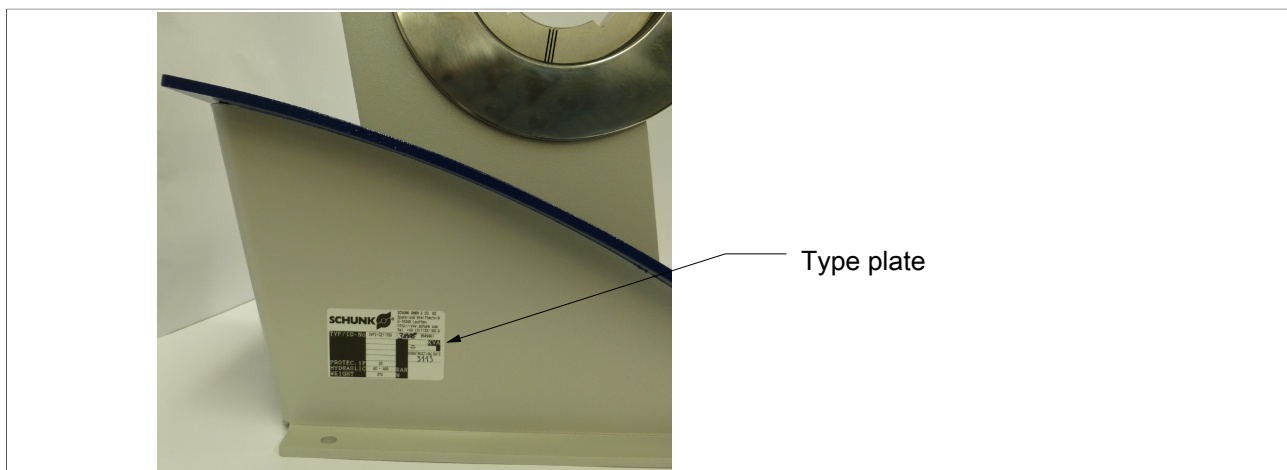

3.3 Content of the type plate

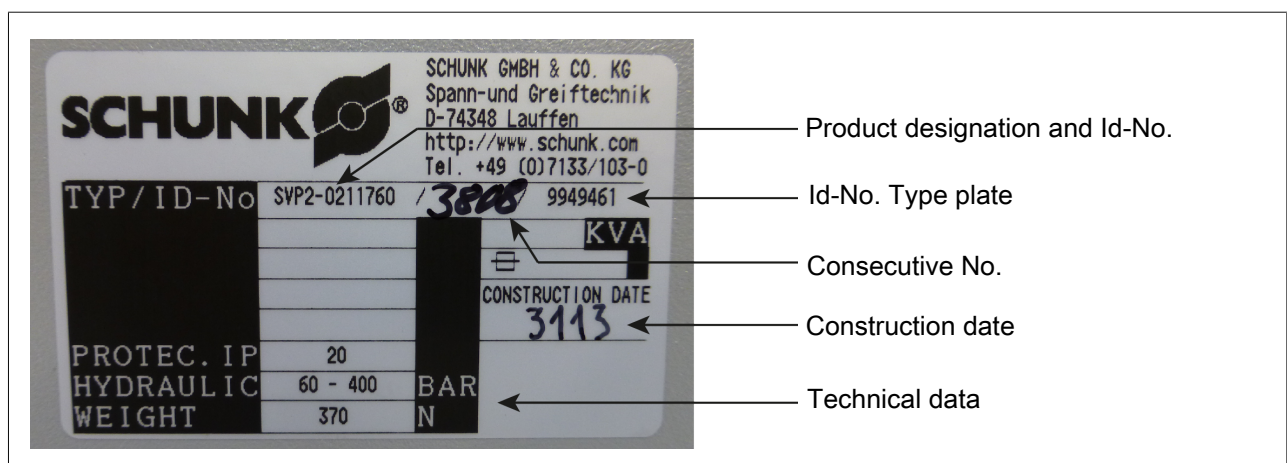

4 Design and description

4.1 Design

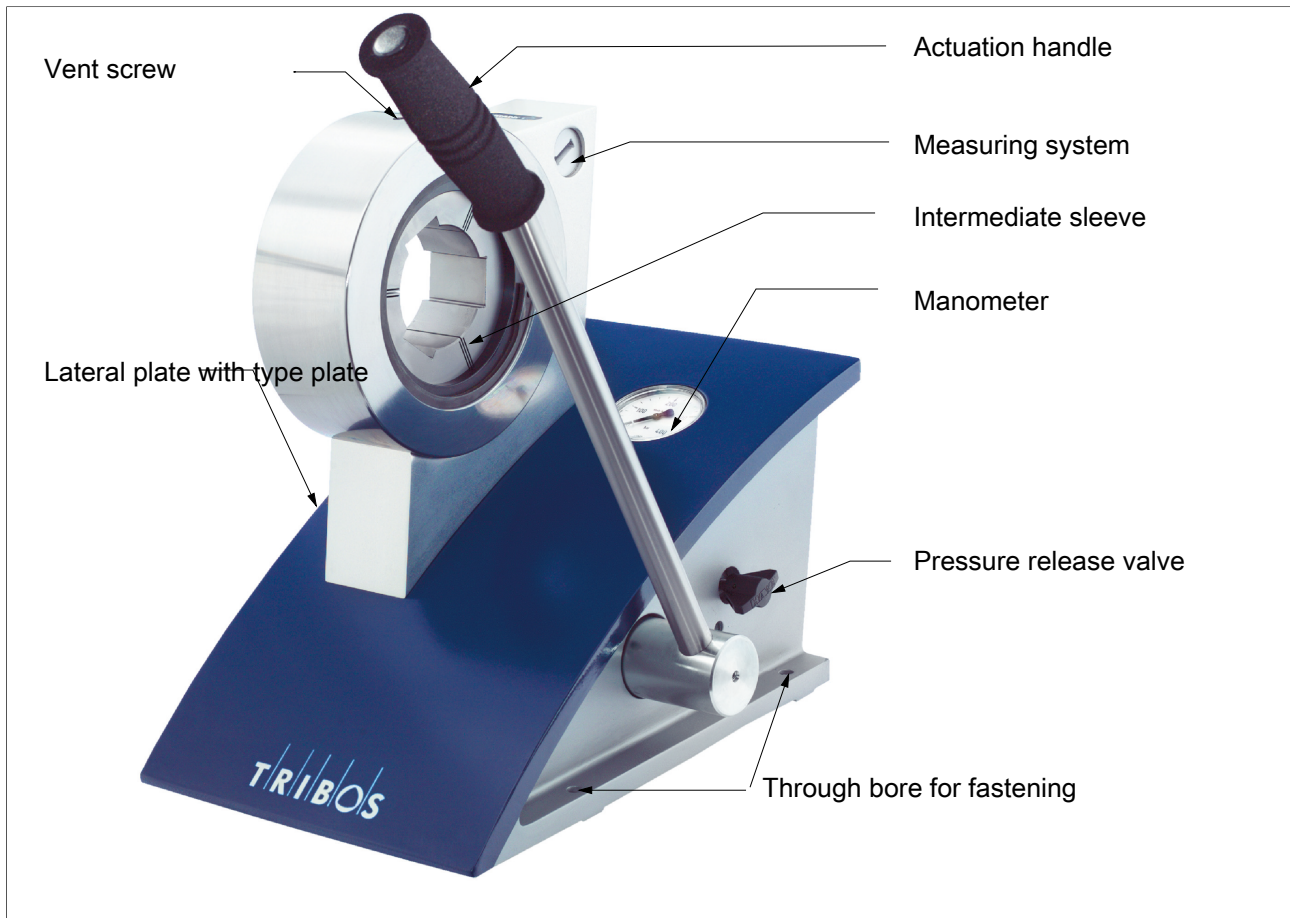

4.2 Description

- Clamping device for a safe and quick tool change.
- With the clamping device clamp TRIBOS tools quickly and evenly.

5 Assembly and settings

5.1 Fastening the clamping device onto a work bench



⚠ WARNING

Risk of injury due to tilting, falling of the clamping device!

Due to tilting, falling of the clamping device hands and feet may be squeezed and jammed.

- Fix clamping device.

In the base plate of the TRIBOS clamping device SVP-2 are four bore holes.

The SVP-2 has to be fastened to a work bench through the mounting holes using four screws M8 and shims (preferably made of plastic to avoid optical damages to the housing)!

5.2 Assembly of the length adjustment

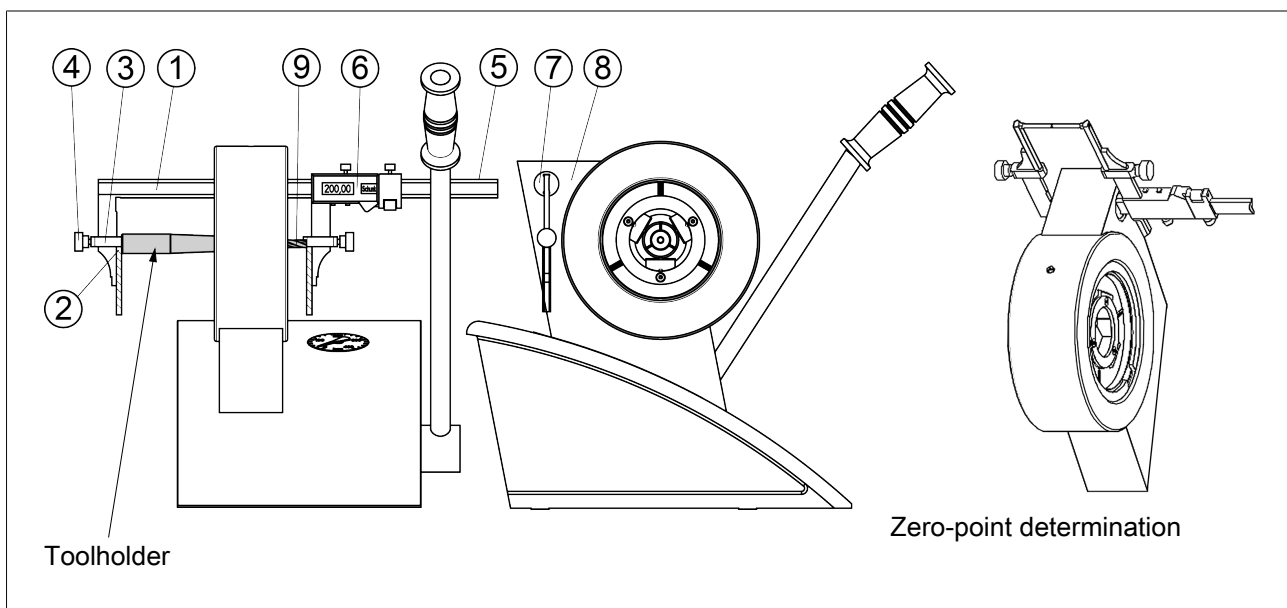

Check that all the parts have been provided:

- 1 Caliper gauge (1)
- 2 Measuring legs (2)
- 2 Brackets for the measuring pins (3)
- 2 Knurled screws (4)
- 1 Safety pin (5)

- Carefully draw the movable side (6) of the caliper gauge (1) away. Then guide the caliper gauge from left to right through the two slotted bearings (7) of the bracket of the base body (8) of the clamping device. Push the movable side (6) again onto the caliper gauge and secure it with the safety pin (5) in the bore on the rear of the caliper gauge.
- In order to reach the cutter of your tool (9), you will need an extension of the caliper gauge side. Turn the knurled screw (4) into the bracket (3). Push one bracket over each side of the caliper gauge (1) and insert the measuring legs (2) into the bracket with the slotted side facing the caliper gauge side (see illustration)
- After having inserted the measuring legs (2) into the required position, fix the bracket (3) with the knurled screw (4).
- To determine the zero point of the caliper gauge, swivel up the two measuring arms and slide towards one another. Set the caliper gauge's display to zero (see illustration).

6 Operation

6.1 Reduction insert and toolholder

Valid for TRIBOS toolholder: Type S / Type R / Type Mini / Type RM / Type SVL

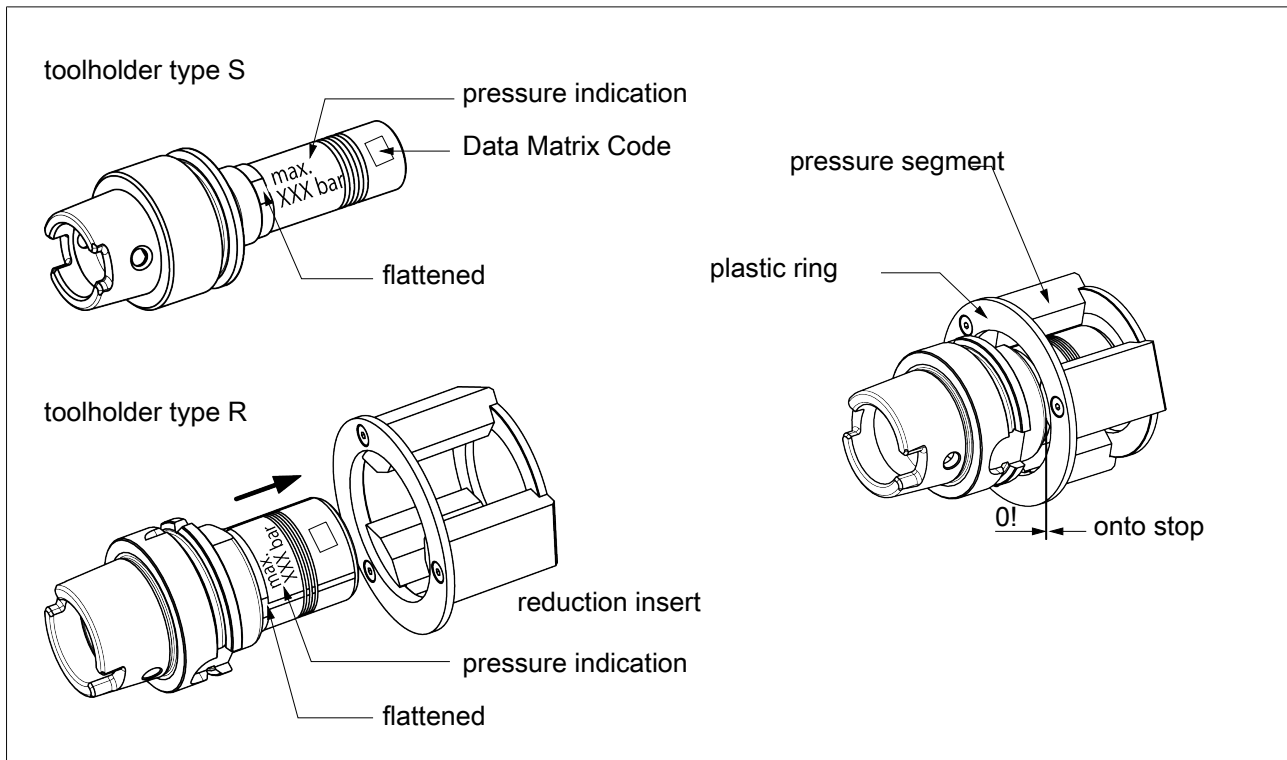

NOTE

Former versions of the toolholder type S haven't been equipped with a locking surface yet. To avoid damages at the toolholders caused by wrong clamping operations please contact SCHUNK (+49-7133-103-2333), before clamping the toolholders in the clamping device SVP-2.

CAUTION

Material damage due to exceeding the permissible pressure!

Too high pressure causes deformation of the toolholder and loss of function.

- Observe the pressure specifications of the toolholder.

CAUTION

Material damage due to incorrect handling!

Deformation of the intermediate sleeve by clamping without reduction insert and TRIBOS toolholder.

- Intermediate sleeve clamp with reduction insert and TRIBOS toolholder only.



⚠ CAUTION

Risk of injury due to sharp-edged tools.

- Wear protective gloves at tool change.
-
- Observe the pressure specifications of the toolholder.
 - Push the reduction insert onto the toolholder until it snaps in via the flattened areas. In order to eliminate possible play between the flattened area and the reduction insert, turn the toolholder, which is clamped into the reduction insert, to the right (clockwise).
 - Slide the reduction insert and the toolholder into the clamping device until the stop. The position is automatically determined by the three segments of the reduction insert in the large intermediate sleeve of the clamping device at an angle of 120°.
 - **IMPORTANT! Check that the toolholder and the reduction insert are correctly inserted to the stop and that any possible toolholder play is eliminated.**
 - Close the pressure release valve and actuate the manual pump until the required pressure is achieved.
 - ✓ The tool/workpiece can be inserted or removed now.
 - To unclamp the device, open the pressure release valve.
 - ✓ The reduction insert with the toolholder can be removed from the clamping device. The toolholder is now ready for use.

6.2 Notes on clamping and unclamping

- Due to the manufacturing and material tolerances, it is possible to insert or loosen tools or work pieces even at a pressure below that indicated on the TRIBOS toolholder.
- **This lower pressure value may be significantly less than that stipulated on the toolholder.**
However, this has no influence on the transmissible torque of the toolholder (see operating manual TRIBOS polygonal tool holder).
- Please make sure that the tool/work piece is still clamped in the toolholder at this time, if the actual unclamping pressure of the clamping device was exceeded! It is also possible that the tool can no longer be inserted into the toolholder at the indicated pressure, but instead at a value that is a few bars below it!
- Continually check the pressure in the clamping device at which the tool/workpiece can be inserted or removed from the toolholder.
- If it proves impossible to loosen or insert the tool or work piece from or into the toolholder until the indicated pressure is achieved, stop the clamping procedure. Release the pressure of the clamping device first and then check that any play between the flattened area of the toolholder and the reduction insert is eliminated by turning the toolholder to the right (clockwise). Repeat the clamping procedure.
- If it proves impossible to loosen or insert the tool/work piece, even though the toolholder is inserted correctly in the reduction insert, unclamp the device and remove the reduction insert and the toolholder. Turn the reduction insert on the toolholder by 120°, push it into the clamping device again and repeat the clamping procedure. It should now be possible to loosen the tool/work piece.
- The tool can become stuck in the toolholder as a result of fine particles in the cooling lubricant. If this is the case, insert a piercer through the rear opening of the TRIBOS toolholder and loosen the tool by pushing or gently hitting it with this piercer.
- Sometimes, the tool shanks are marked. These markings are often "wrapped". This impairs the insertion of the TRIBOS toolholder or even makes an insertion impossible. In this case, re-move the wrapping.

- Tool shanks with clearances, especially DIN 1835 shape E or DIN 6535 shape HE are often twisted and can therefore frequently not be inserted into the TRIBOS toolholder or quickly lead to poor run-out accuracy. The same is also true of tool shanks that fall below h6 quality (no torque) or exceed it (not joinable).

For clamping shanks of shape E or HE, please consider the position of the flattening to the pressure segments:

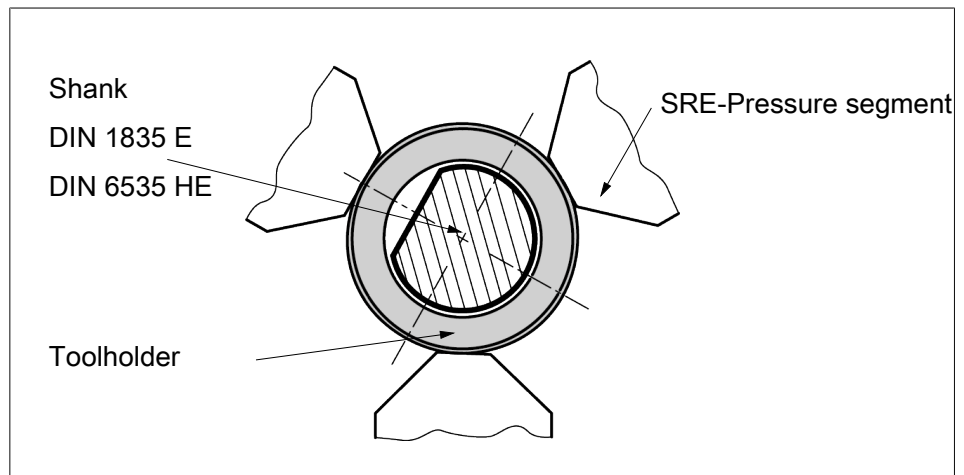



At this shank position in the TRIBOS toolholder the clamping faces are positioned at the round shank and thus achieve the effect of a "round shank clamp". The hardness at the tool shank should be min. HRC 50 (shank stiffness min. 1000 N/mm²) in order to avoid a deformation of the tool shank. If the degree of hardness or stiffness should be lower, the compression joint is not properly covered and therefore results a reduced force transmission of the clamping system.



6.3 TRIBOS pressure table

Generally the following applies: Observe TRIBOS pressure table

Auf Anschlag einschieben | Insert until stop
 Auf Indexierfläche einrasten | Engage on indexing surface
 Spanndruckbereich beachten! | Consider range of clamping pressure!

Spann-Ø [mm] Clamping-Ø [mm]	Druck Pressure [bar]	max. [bar]
TRIBOS-S 		
TRIBOS-SVL		
6	120-180	210
7	140-210	220
8	150-220	250
9	160-240	250
10	180-250	280
11	180-270	280
12	210-280	310
13	240-320	340
14	240-310	330
15	260-330	350
16	270-330	350
17	280-360	370
18	290-350	370
20	300-350	370
25	320-370	380
32	270-310	320
1/4"	130-200	210
5/16"	170-240	260
3/8"	190-250	270
7/16"	200-270	290
1/2"	220-310	320
5/8"	280-350	380
3/4"	290-360	380
1"	300-360	380
1 1/4"	270-320	340

Spann-Ø [mm] Clamping-Ø [mm]	Druck Pressure [bar]	max. [bar]
TRIBOS-R 		
6	110-160	170
7	120-180	180
8	120-170	180
9	180-250	260
10	180-240	260
11	230-300	320
12	250-300	320
13	240-320	330
14	280-320	340
15	270-320	340
16	280-320	340
17	240-290	310
18	300-340	360
20	320-360	380
25	300-340	350
32	270-300	310
1/4"	100-160	160
3/8"	180-250	280
1/2"	220-290	320
5/8"	280-320	350
3/4"	280-330	350
1"	270-300	320
1 1/4"	200-250	260

Spann-Ø [mm] Clamping-Ø [mm]	Außen-Ø [mm] Outer-Ø [mm]	Druck Pressure [bar]	max. [bar]	Schnittstelle Interface
TRIBOS-Mini 				
TRIBOS-Mini-SVL				
1-4	6.65	42-55	55	ER 11
1-6	9	60-85	85	ER 16/20/25/32, HJND 50
1/8"	6.65	42-55	55	ER 11
3/16"	6.65	42-55	55	ER 11
1/8"	9	60-85	85	ER 16/20/25/32
3/16"	9	60-85	85	ER 16/20/25/32
1/4"	9	60-85	85	ER 16/20/25/32
TRIBOS-RM 				
3-8	14	70-115	115	ER 20, HJND 50/28
3-6	18	80-120	120	WK 16
3-12	18	100-140	140	ER 25/32
3-12	20	150-160	160	WK 19
3-12	20	110-180	180	HJND 28
3-12	25	190-260	260	HJND 21
3-16	32	280-380	380	
3/8"	18	100-140	140	ER 25/32
TRIBOS-S HSK-F 63				
25	35	280-300	310	

Verriegelung Handbedienung
Locking manual operation

Sperrcode lock code 

Entsperrcode unlock code 

9938414-172019 © 2019SCHUNK GmbH & Co. KG

7 Troubleshooting

7.1 Tool shank cannot be inserted if pressure is built up

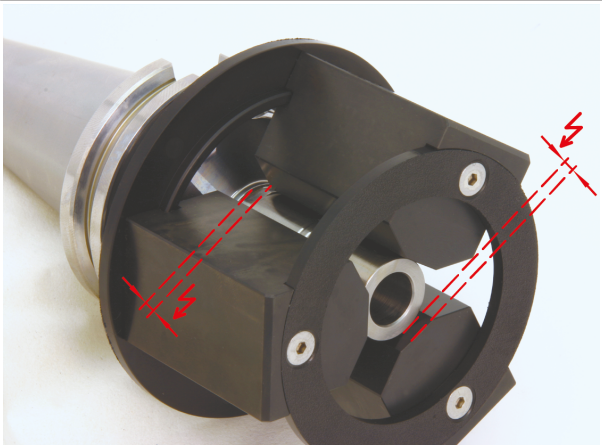
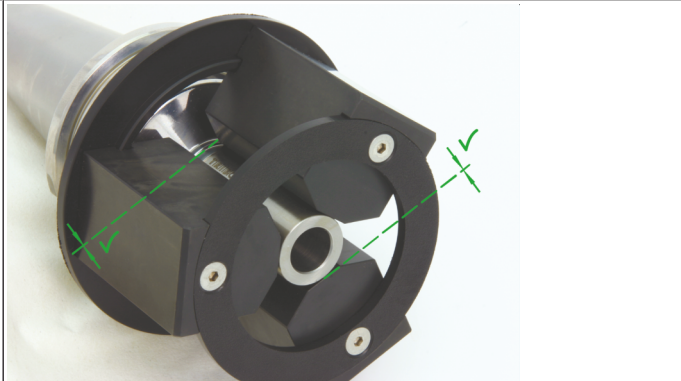
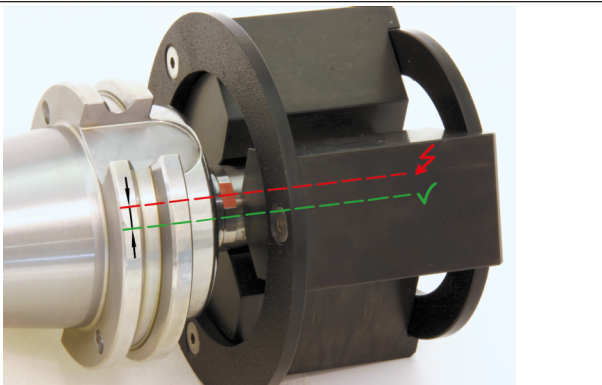
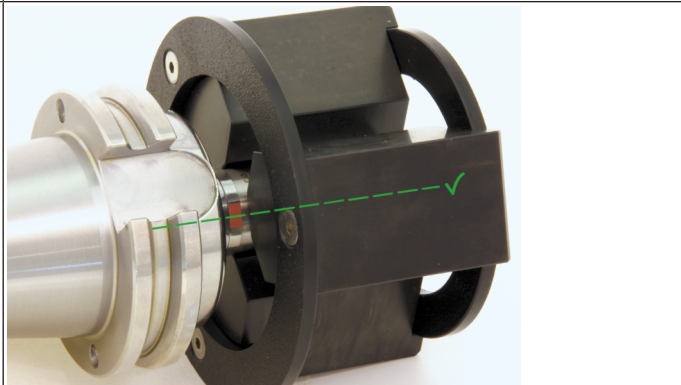
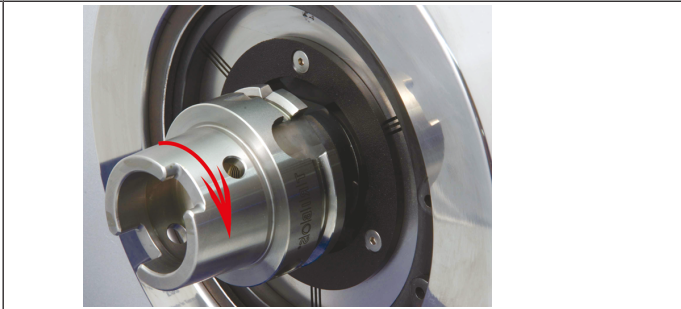
Possible cause	Corrective action
 <p data-bbox="153 817 758 949">Toolholder has not fully engaged with the engaging areas of the reduction insert. Toolholder not placed on end stop.</p>	 <p data-bbox="758 750 1441 949">Engage toolholder properly and place on end stop.</p>
 <p data-bbox="153 1344 758 1518">Wrong toolholder/reduction insert angle. Too much pressure could have been applied to toolholder/reduction insert causing constant deformation.</p>	 <p data-bbox="758 1344 1441 1518">Ensure correct angle position of toolholder/reduction insert (engaging surface must be aligned with the segment).</p>
<p data-bbox="153 1518 758 1601">TRIBOS toolholder not turned to right-hand stop.</p>	 <p data-bbox="758 1836 1441 1881">Turn TRIBOS toolholder to right-hand stop</p>

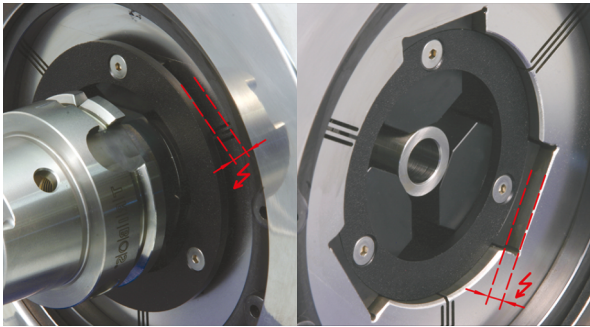
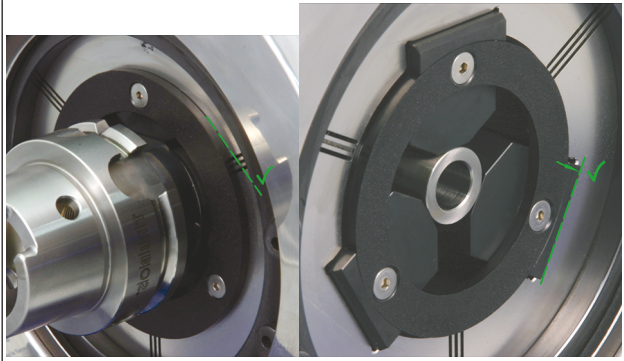
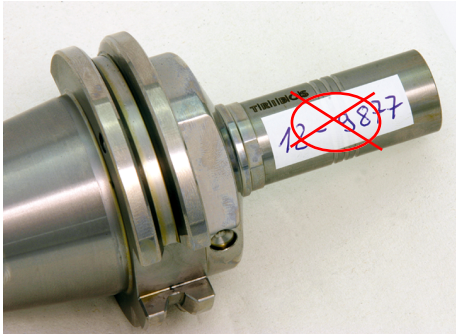
Possible cause	Corrective action
 <p>Reduction insert not inserted up to the stop into intermediate sleeve of the clamping device.</p>	 <p>Insert reduction insert up to the stop into the intermediate sleeve of the clamping device.</p>
<p>Shank is too large. Shank does not have the required tolerance h6.</p>	<p>Use tool shank with tolerance h6.</p>
<p>Clamping pressure too low or too high (wrong pressure value was entered). Toolholder has already been over-pressurized before.</p>	<p>Observe TRIBOS pressure table (do not exceed max. pressure).</p>
<p>Clamping area dirty.</p>	<p>Keep clamping area clean.</p>
 <p>Stickers or the like on the clamping area.</p>	<p>Keep clamping area clean at the outer diameter. It must be possible to insert the reduction insert properly.</p>

7.2 Tool shank can only be partially inserted into the toolholder

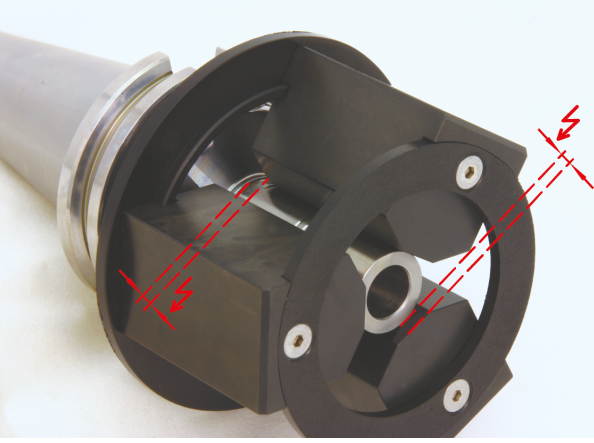
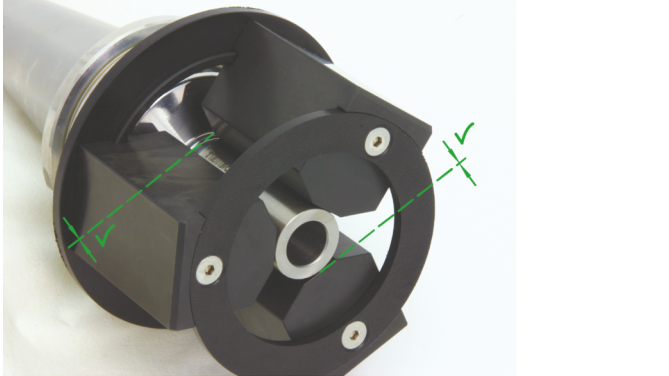
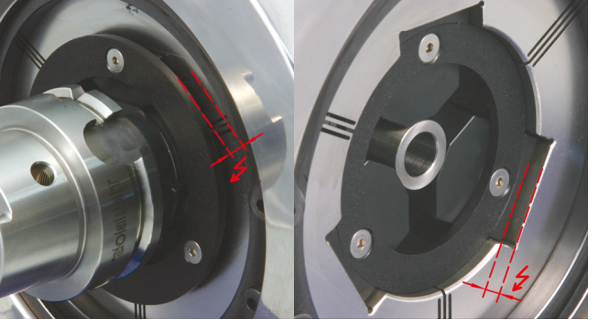
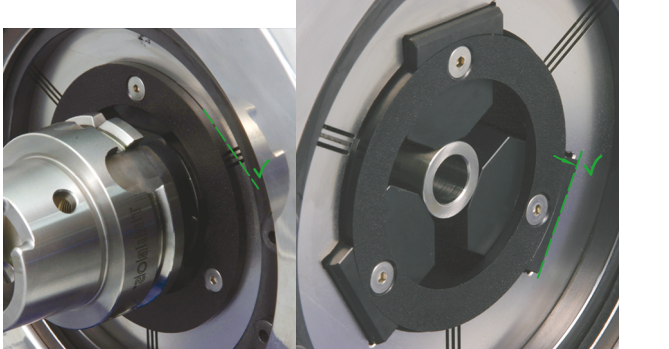
Possible cause	Corrective action
 <p data-bbox="156 757 753 835">Toolholder has not fully engaged with the engaging areas of the reduction insert.</p>	 <p data-bbox="762 696 1433 730">Engage toolholder properly.</p>
 <p data-bbox="156 1182 753 1294">Reduction insert not inserted up to the stop into intermediate sleeve of the clamping device.</p>	 <p data-bbox="762 1211 1433 1294">Insert reduction insert up to the stop into the intermediate sleeve of the clamping device.</p>
<p data-bbox="156 1305 753 1377">Bad quality of tool shank e.g. it may have a slightly conical shape.</p>	<p data-bbox="762 1305 1433 1377">Check tool shank. Use tool shank with tolerance h6.</p>

7.3 Tool cannot be removed from the toolholder

Possible cause	Corrective action
Frictional corrosion / contact corrosion	Actuate clamping device on release pressure for the toolholder. Drive out the tool shank using a hammer and a suitable drift punch. Clean clamping bore and tool and carry out new clamping procedure.
 <p data-bbox="151 853 758 898">Stickers or the like on the clamping area</p>	Keep clamping area clean at the outer diameter. It must be possible to seat the reduction insert properly.
 <p data-bbox="151 1256 758 1339">Laser inscription located on tool shank.</p>	 <p data-bbox="758 1256 1441 1339">Remove or smoothen inscription on the shank with a fine emery paper or a grinding stone.</p>
Tool broke off.	Actuate clamping device on release pressure for the toolholder. Drive out the tool shank using a hammer and a suitable drift punch. Clean clamping bore and clamp new tool.

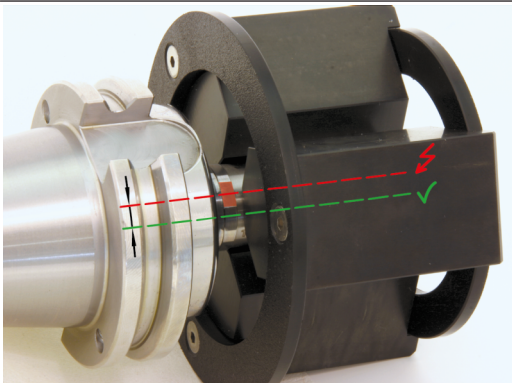

7.4 Tool shank can be inserted outside the pressure range if slight pressure is applied

Possible cause	Corrective action
 <p>Toolholder pressed in wrong angle (clamping area is deformed). Toolholder has been over-pressurized (clamping area distorted).</p>	<p>Send back the toolholder to SCHUNK for inspection/repair. Observe TRIBOS pressure table (do not exceed max. pressure).</p>
<p>Shank does not have the required tolerance h6. Tool shank is under-dimensioned (< h6).</p>	<p>Use tool shank with tolerance h6.</p>

7.5 Tool shank can yet not be inserted at maximum pressure

Possible cause	Corrective action
<p>Shank does not have the required tolerance h6, tool shank is too big (> h6).</p>	<p>Use tool shank with tolerance h6.</p>

7.6 Clamping device does not build up pressure

Possible cause	Corrective action
 <p>Hydraulic valve on pump housing is open.</p>	 <p>Close hydraulic valve.</p>

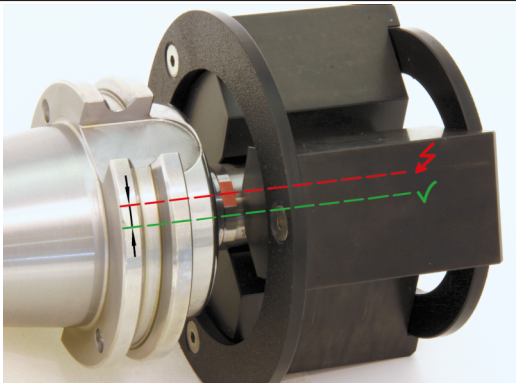
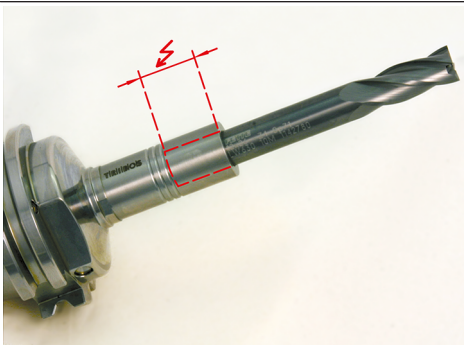
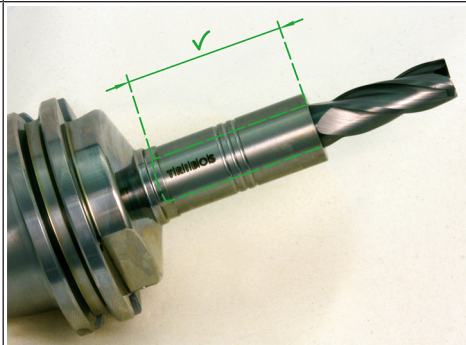

7.7 Torque / clamping force / holding force too low

Possible cause	Corrective action
 <p>Toolholder pressed in wrong angle (clamping area is deformed). Toolholder has been over-pressurized, which means charged with too much pressure (clamping area deformed).</p>	<p>Send the toolholder to SCHUNK for inspection/repair. Observe TRIBOS pressure table (do not exceed max. pressure).</p>
<p>Shank does not have the required tolerance h6. Tool shank is under-dimensioned (< h6).</p>	<p>Use tool shank with tolerance h6.</p>
 <p>Minimum shank clamping depth was not observed.</p>	 <p>Observe minimum shank clamping depth (see operating manuals TRIBOS polygonal toolholder).</p>
<p>Lubricant film on tool shank and/or on clamping area.</p>	<p>De-grease and clean clamping area and tool shank.</p>
<p>Toolholder and tool were inserted with wrong (too high) cutting data.</p>	<p>Adjust cutting data/cutting values.</p>

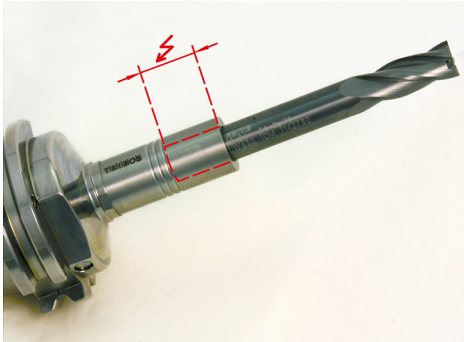
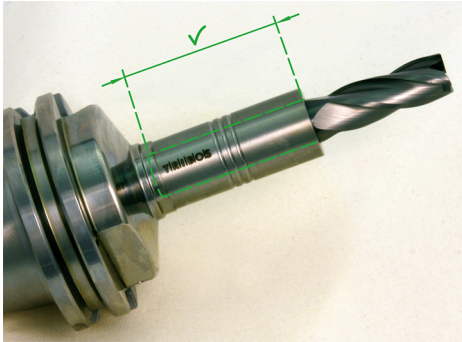
7.8 Concentricity errors on the clamped tool

Possible cause	Corrective action
Toolholder damaged, improper handling.	Check toolholder for collision or damage and send back to SCHUNK for inspection/repair if necessary.
Machine spindle damaged, concentricity error/axial eccentricity error on the machine spindle.	Check machine spindle for damage and check true running.
Tool has not been grinded properly.	Check tool and, if necessary, replace it.
Tool shank not fully cylindrical.	Use fully cylindrical tool shanks.
 <p>Minimum shank clamping depth was not observed.</p>	 <p>Observe minimum shank clamping depth (see operating manuals TRIBOS polygonal toolholder).</p>

7.9 SVP-2 clamping device does not reach required pressure

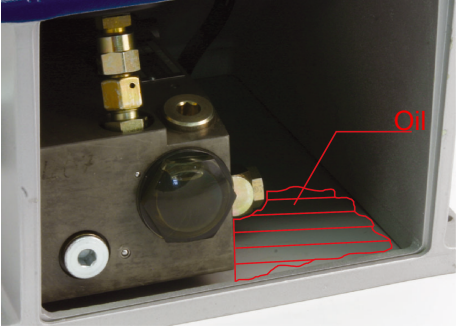
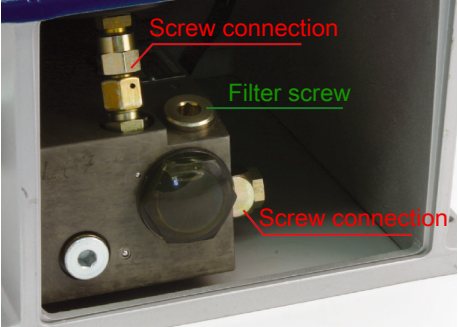
Possible cause	Corrective action
 <p>Hydraulic valve on pump housing is open.</p>	 <p>Close hydraulic valve.</p>
 <p>Oil leakage at TRIBOS pressure body (seal)</p>	<p>Replace seal Send clamping device to SCHUNK for inspection/repair</p>
 <p>Oil leakage at TRIBOS body (screw connection)</p>	<p>Check screw connection Send the clamping device to SCHUNK for inspection/repair</p>
 <p>Oil leakage at TRIBOS pressure body (screw connection, terminal block)</p>	<p>Retighten screw connections, refill with oil if necessary and vent clamping device Care and storage [▶ 29].</p>

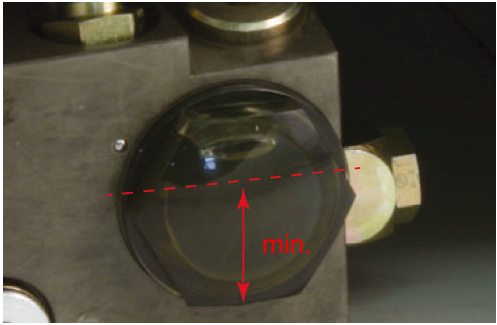
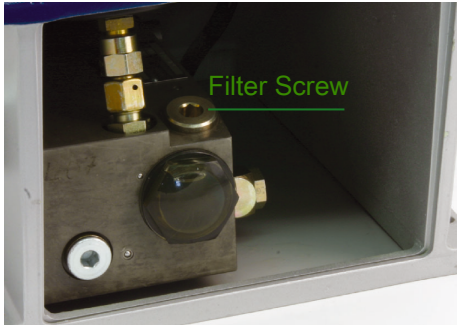
Possible cause	Corrective action
 <p data-bbox="156 600 702 638">Not enough oil in the clamping device.</p>	 <p data-bbox="762 600 1380 678">Refill compensation unit and vent clamping device.</p>

7.10 Oil leaking out of the clamping device

Possible cause	Corrective action
 <p data-bbox="156 1102 646 1137">Oil leakage at pressure body (seal)</p>	<p data-bbox="762 817 1340 940">Replace seal. send the clamping device to SCHUNK for inspection/repair</p>

8 Maintenance

8.1 Care and storage

- Store the TRIBOS clamping device in unpressurized condition.
- Only store and use the TRIBOS clamping device in horizontal position, because it is just intended for horizontal applications. Otherwise, the pump may draw with air.
- Before storing, lightly lubricate the TRIBOS clamping device, the reduction insert and the TRIBOS toolholder.
- If the TRIBOS clamping device is not used for a longer period of time, cover it with the optionally available protective cover.
- Each time the tool/work piece is changed, clean the clamping diameter in the clamping area. (Suitable cylindrical brushes are available separately).
- If the desired pressure can no longer be achieved, check the oil level in the container inside the housing. To open the housing, loosen the 4 screws at the back and remove the back wall. The oil level can now be checked and, if necessary, oil can be refilled. The oil container should always be full.
- If there is air in the pressure system (caused by improper storage or insufficient oil in the oil container), release the air via the air vent positioned at the top inside of the pressure hull. To release air, slightly unscrew the vent screw and pump with the actuation handle until the air escaped (oil leaks a little). Close the vent screw (tightening torque max. 3 Nm) and check the oil level of the container. If necessary, refill oil.

8.2 Maintenance and service

Service and repair work should only be carried out in accordance with the service instructions by qualified personnel. This includes SCHUNK service technicians or qualified technicians trained by SCHUNK.

9 Transport and disposal

9.1 Transport

For transport use the original SCHUNK packing. Transport the clamping device only horizontally.



⚠ CAUTION

Risk of injury due to unsuitable means of transport!

The use of unsuitable means of transport can cause injuries.

- Use suitable means of transport.

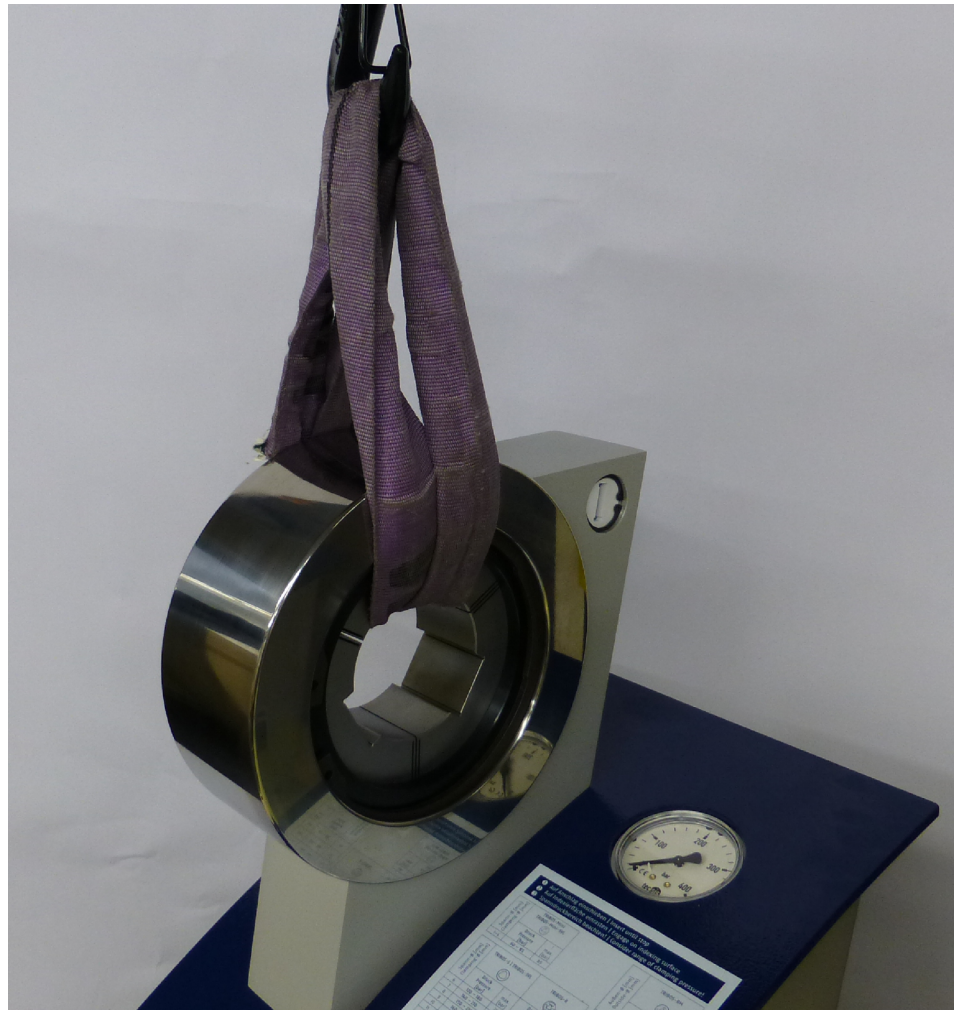

9.2 Disposal

For proper disposal, return the clamping device to SCHUNK.

10 Short manual

