

## Original Assembly and Maintenance Instructions

Portal linear unit

**HSB-gamma**

Types

Gamma 90-ZSSD

Gamma 120-ZSSD

Gamma 160-ZSSD

Gamma 220-ZSSD

Gamma 280-ZSSD

HSB Automation GmbH  
In Laisen 74  
72766 Reutlingen  
Germany  
Tel. +49 7121 14498-0  
info@HSB-Automation.de  
www.HSB-Automation.de

Distributor:  
SCHUNK GmbH & Co. KG  
Spann- und Greiftechnik  
Bahnhofstr. 106 - 134  
74348 Lauffen/Neckar  
Deutschland  
Tel. +49 7133-103-0  
Fax +49 7133-103-2399  
info@de.schunk.com  
www.schunk.com



## Table of contents

<b>1</b>	<b>Safety</b> .....	<b>2</b>
1.1	Symbols used .....	2
1.2	Intended use.....	2
1.3	General safety .....	3
1.4	Use in potentially explosive areas.....	3
1.5	Technical condition of the linear unit.....	3
1.6	Changes to the linear unit.....	3
1.7	Requirements for personnel.....	4
1.8	Responsibilities of the operator.....	4
<b>2</b>	<b>Warranty</b> .....	<b>4</b>
<b>3</b>	<b>Technical Data - Standard design</b> .....	<b>5</b>
<b>4</b>	<b>Product description</b> .....	<b>8</b>
<b>5</b>	<b>Transport and Storage</b> .....	<b>9</b>
<b>6</b>	<b>Assembly and Alignment</b> .....	<b>10</b>
6.1	Screw linear unit into place from underneath .....	10
6.2	Set maximum stroke.....	11
6.3	Installing the drive.....	11
6.3.1	Installing the motor.....	11
<b>7</b>	<b>Commissioning</b> .....	<b>13</b>
<b>8</b>	<b>Operation</b> .....	<b>14</b>
<b>9</b>	<b>Decommissioning</b> .....	<b>15</b>
<b>10</b>	<b>Maintenance</b> .....	<b>15</b>
10.1	Lubrication.....	16
10.2	Replacing the toothed belt .....	19
10.3	Your added value in service: Repair and Retrofit.....	20

# 1 Safety

These Operating Instructions are an important part of the machine and must always be kept within reach.

They must be passed on together with the machine to any third party.

It is important that you contact the manufacturer should there be any part of these instructions that you do not clearly understand.

## 1.1 Symbols used

In these Operating Instructions, the following warning symbols and other symbols are used:

DANGER



Indicates immediate danger.

Failure to comply with this instruction may result in death or serious injury.

WARNING



Indicates a danger carrying a medium to high risk.

Failure to comply with this instruction may result in death or serious injury.

CAUTION



Indicates a danger carrying low risk.

Failure to comply with this instruction may result in slight injury or material damage.

 Note

Includes tips for the operation and optimum use of the machine.

## 1.2 Intended use

The linear unit is solely intended for the purpose of manipulating, positioning, transporting, palletising, loading, unloading, clamping, synchronising, tensioning, testing, measuring, handling and pressing of component parts or tools.

Please take note of the principal fields of application of the linear unit (see Section 4 and Section 3).

In order to guarantee compliance with the law concerning the electromagnetic compatibility of devices (EMC directive), the linear unit may only be used for industrial applications (in accordance with EN 61000-6-1).

Utilisation of the machine for any other purpose would constitute inappropriate use. The manufacturer accepts no liability for any damages resulting from such use. The risk is borne solely by the user.

## 1.3 General safety

<b>Date of commissioning</b>	<p>The linear unit may be operated only when the machine or installation into which it has been built is found to comply with the following guidelines, laws, regulations and standards:</p> <ul style="list-style-type: none"> <li>• EC/EU directives,</li> <li>• standards regarding the electromagnetic compatibility of devices or machinery,</li> </ul>
<b>Safe operation</b>	<p>For safe operation, please take into account the following documentation:</p> <ul style="list-style-type: none"> <li>• these Operating Instructions for the linear unit, in particular the Technical Specifications</li> <li>• the Operating Instructions for the entire installation</li> </ul>
<b>Decommissioning</b>	<p>Dispose of the product in accordance with the applicable national requirements. Observe the safety data sheets.</p>

## 1.4 Use in potentially explosive areas



The linear units are not suitable for use in potentially explosive atmospheres.

## 1.5 Technical condition of the linear unit

<b>State of the art</b>	<p>The unit conforms to the current state of the art and applicable rules and regulations. The device complies with the EC Machinery Directive and the relevant Harmonised Standards (European standards). Furthermore, the EC Declaration of Incorporation applies.</p>
-------------------------	--

## 1.6 Changes to the linear unit

<b>Rebuilding and modifying</b>	<p>There are to be no changes, either structural or safety-related, carried out on the linear unit without the prior written agreement of HRB. We accept no liability for any unauthorised changes carried out on the unit.</p> <p>The operator may only carry out the maintenance and repair work specified in these Operating Instructions. Any further work involving the replacement of wearing or spare parts may only be carried out following consultation with our service technicians and by the service technicians themselves or by HRB.</p> <p>Never remove or decommission any safety or protection devices.</p> <p>Follow the assembly instructions supplied by the manufacturer when using special attachments.</p>
---------------------------------	--

## 1.7 Requirements for personnel

Any work involving live parts may only be carried out by trained electricians. This work involves, for example:

- installation of safety limit switches,
- attachment of a drive,
- checking the direction of the drive rotation.

## 1.8 Responsibilities of the operator

<b>Preservation of labels</b>	The operator must ensure that any lettering, information signs or labels are fully legible (in particular the serial number) and always observed. Any damaged or illegible information signs and labels must be replaced.
<b>Accident Prevention and Environmental Protection</b>	The applicable regulations for accident prevention and environmental protection must be observed.
<b>Disposal</b>	Dispose of the product according to the relevant national regulations. Refer to the safety data sheets.

## 2 Warranty

The warranty conditions are specified in the sales documents (delivery and payment conditions). The warranty claim expires if:

- the unit has not been used in accordance with its intended use,
- these Operating Instructions have not been adhered to,
- the unit has been modified without prior authorisation from the manufacturer,
- screws sealed using locking paint have been opened.

The manufacturer is only liable if genuine spare parts have been used during any maintenance or repair work carried out on the unit.

### 3 Technical Data - Standard design

Gamma ZSSD Linear Unit	Unit sizes				
	90	120	160	220	280
Drive element	Toothed belt				
	16AT10	25ATL10	32AT10	40AT10	50ATL10
Moment of inertia [kgm <sup>2</sup> ]	2.20 x 10 <sup>-3</sup>	3.85 x 10 <sup>-3</sup>	8.70 x 10 <sup>-3</sup>	1.55 x 10 <sup>-2</sup>	0.12
Stroke per revolution [mm]	200	200	210	240	300
Max. speed [m/s]	5	5	5	5	5
Max. acceleration [m/s <sup>2</sup> ]	60	60	60	60	60
Idle torque [Nm]	2.90	3.00	4.00	5.25	11.00
Maximum stroke (standard) [mm]	7560	7638	7240	11200	8940
Length of standard sliding carriage [mm]	140	150	300	320	400
Repeat accuracy [mm]	±0,08	±0,08	±0,08	±0,08	±0,08
Operating temperature [°C] (Continuous operation)	0 ... 80	0 ... 80	0 ... 80	0 ... 80	0 ... 80
Geometrical moment of inertia I <sub>y</sub> [mm <sup>4</sup> ]	1373211	4636416	9549307	22898225	52178042
Geometrical moment of inertia I <sub>z</sub> [mm <sup>4</sup> ]	2297416	6696292	18710430	53494083	131592116
Weight (without stroke) [kg]	11.50	19.40	39.80	57.50	135.00
Weight (per 100 mm stroke) [kg]	0.96	1.90	2.50	3.60	5.50
Weight of standard sliding carriage [kg]	1.90	3.40	7.00	9.30	18.,00
Max. noise emission [dB A] <sup>1)</sup>	75	75	75	75	75

<sup>1)</sup> The value changes when assembled with other parts of the installation

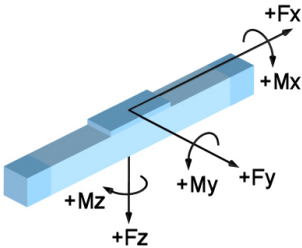

**Forces and moments for Gamma linear unit with toothed belt drive**

Type designation	Dynamic forces [Nm]				Dynamic moments [Nm]			
	F <sub>x</sub>	F <sub>y</sub>	F <sub>z</sub>	-F <sub>z</sub>	M <sub>x</sub>	M <sub>y</sub>	M <sub>z</sub>	M <sub>idle</sub>
Gamma 90-ZSSD	1150	2500	3000	3000	500	800	700	2.90
Gamma 120-ZSSD	1800	6000	8000	8000	1200	1300	1100	3.00
Gamma 160-ZSSD	2200	10000	16000	16000	1800	5000	4000	4.00
Gamma 220-ZSSD	2800	12000	20000	20000	2500	8000	6500	5.25
Gamma 280-ZSSD	4000	20000	30000	30000	4000	15000	12000	11.00

*M<sub>idle</sub> = Idle torque ±30%*

*The specified forces and moments are the respective maximum values for the single load. The individual values must be reduced for a mixed load or the occurrence of several moments or forces at the same time. If in doubt, please contact Technical Support.*

**Dynamic load ratings for the Gamma ZSSD linear unit**

(THK and Rex = Rexroth)

Unit size	Size	No. of rails	No. of carriages	Load rating per carriage C <sub>dyn</sub> [N] THK / Rex	Pretensioning F <sub>v</sub> [N] THK / Rex	Guiding distance in direction x (lx1) [mm]	Guiding distance in direction y (ly) [mm]
Gamma 90-ZSSD	15	2	4	11271 / 9860	564 / 620	75	73
Gamma 120-ZSSD	20	2	4	17700 / 23400	885 / 1500	104	80
Gamma 160-ZSSD	25	2	4	25160 / 28600	1258 / 1820	208	120
Gamma 220-ZSSD	25L	2	4	29208 / 37300	1460 / 2430	210	180
Gamma 280-ZSSD	35	2	4	49448 / 51800	2472 / 3350	275	236

*The load rating and pretensioning values refer to the standard linear guide system*

Tightening torques [Nm] for fixing screws							
Fixing screws	M4	M5	M6	M8	M10	M12	The figures given are intended as guides. For shorter insertion depths, the figures must be adjusted accordingly.
DIN912/ISO4762-8.8	2,7	5,4	9,0	22,0	43,0	74,0	
DIN912/ISO4762-10.9	3,0	5,7	9,0	22,0	43,0	74,0	
DIN912/ISO4762-12.9	3,0	5,7	9,0	22,0	43,0	74,0	

Tightening torques [Nm] for coupling with clamping hub					
Size	14	19	24	28	38
Coupling diameter [mm]	30	40	55	65	80
Screw size	M3	M6	M6	M8	M8
Tightening torque [Nm]	1.34	10.50	10.50	25.00	25.00

Tightening torques [Nm] for coupling with clamping hub					
Size	14	19	24	28	38
Coupling diameter [mm]	30	40	55	65	80
Screw size	M3	M4	M5	M5	M6
Tightening torque [Nm]	1.34	2.90	6.00	6.00	10.00

## 4 Product description

### Rail guide elements

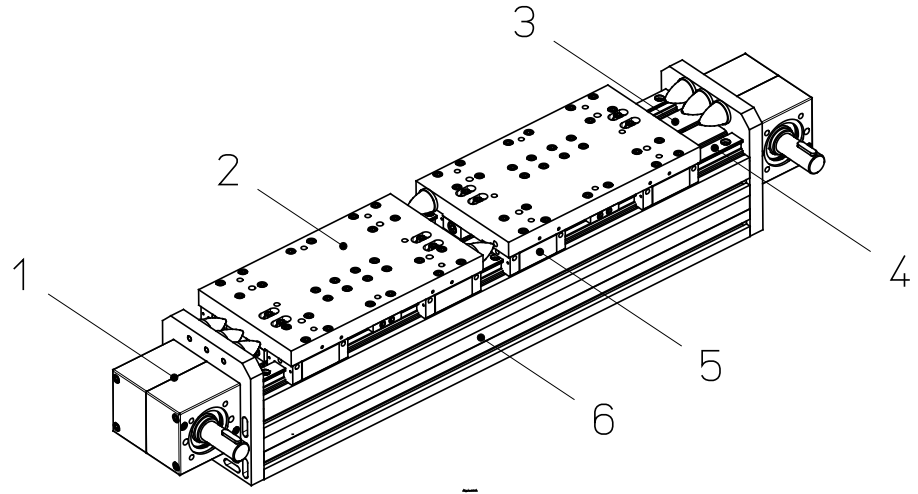

Legend	1	Bearing housing	4	Guide rail
	2	Carriages	5	Guide carriage
	3	Toothed belt	6	Base profile

Figure 1: Guide elements for Gamma ZSSD linear unit

A mechanical linear unit converts rotary motion into linear motion and thus facilitates fast, safe and accurate movement of loads from one position to another. It consists of a basic aluminium profile, a moveable carriage which is supported by a guide element (linear guide system) and a drive element (rack-and-pinion or toothed belt drive).

Depending on the design, the carriage can absorb forces and moments in all directions and is non-positively connected to the guide and drive element via the slide plate.

The basic profile is self-supporting up to a certain length and fitted with grooves to keep it in place.

The operating area can be flexibly arranged. Several Gamma linear units can be configured to cover a large area (2 axes) or in a spatial arrangement (3 axes).

A plate can be used to connect driven linear units to non-driven linear units of the same type, for example in order to be able to take on large loads.

## 5 Transport and Storage

The mechanical linear unit is a precision instrument. Any heavy impact to this instrument may damage the mechanics and impair its functionality.

CAUTION



---

Risk of damage by heavy impact or bending!

Only transport an assembled linear unit using transport locks.

---

In order to avoid any damage to the linear unit when storing or transporting it, the following measures must be taken in order to protect it from jolting or slipping:

- Transport the unit in a sufficiently large container
- Use cushioned packaging

The weight values for the units are listed in section 3.

The units must be protected against:

- Dirt,
- Corrosion,
- Water
- and an aggressive atmosphere.

## 6 Assembly and Alignment

The linear unit can be mounted as follows:

- With screws in the sliding blocks
- With screws in the factory-fitted threaded rails

☛ Only mount the linear unit onto a flat surface. Standard parallelism <math><0.2 \text{ mm}/1000 \text{ mm}</math>.

☛ Mounting the linear unit using the threaded rails is recommended for the following situations:

- For highly dynamic applications
- For just 2 fixing points on the linear unit

### 6.1 Screw linear unit into place from underneath

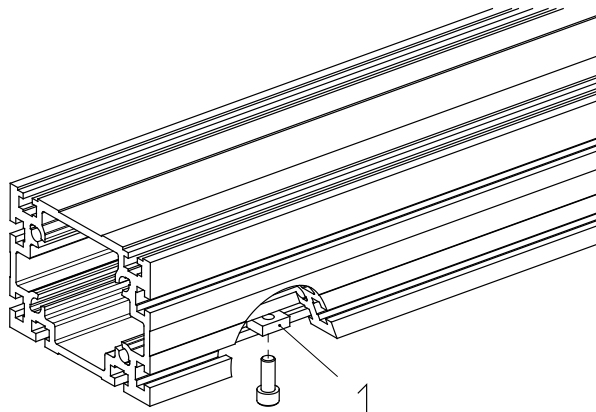

Figure 2: Sliding blocks (1) in the groove on the underside of the basic profile

Secure the linear unit using fastening screws from below using the sliding blocks or the threaded rails in the basic aluminium profile (Figure 2).

**Proceed as follows:**

1. Align the linear unit.
2. Align the sliding blocks (1) / threaded rails.
3. Screw the linear unit into place (for tightening torques refer to section 3).

## 6.2 Set maximum stroke

**WARNING**



Risk of serious injury from overturning transport devices.  
Should the carriage come to a stop beyond the safety area, the transport devices mounted to this can break off or overturn. This can damage the linear unit.

Please take note of the specified safety area when setting up the unit and set the limit switch correspondingly.

Electric switches may only be connected by a qualified electrician.

☛ Allow for a sufficient braking distance to ensure that there is enough time to slow down the carriage in the case of an emergency stop.

## 6.3 Installing the drive

### 6.3.1 Installing the motor

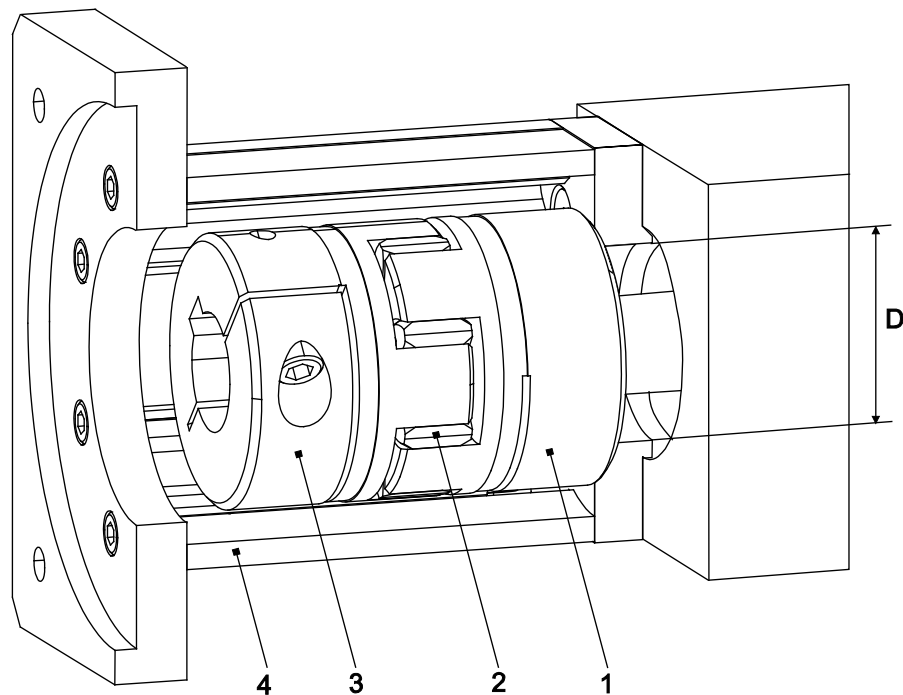

Legend	1	Coupling half 1	4	Motor mounting
	2	Coupling collar	D	Diameter at motor mounting
	3	Coupling half 2		

Figure 3 Motor mounting with motor coupling at drive journal

- Proceed as follows:**
1. Place the motor and the coupling elements in the mounting position alongside the linear unit.
  2. Check the direction of rotation of the motor. If necessary, adjust the direction of rotation.
  3. If the coupling diameter is smaller than the D measurement at the motor mounting (4), first mount the coupling half 1 (1) (bore flush with the drive shaft) and then the motor mounting (4) (Figure 3).

If the coupling diameter is larger than the D measurement at the motor mounting (4), first mount the motor mounting (4) and then the coupling half 1 (1) (bore flush with the drive shaft). Tighten the coupling clamping screw using the mounting bore at the motor mounting (4).

4. If necessary, push the coupling collar (2) onto the coupling.
5. Fix the coupling half 2 (3) to the motor journal.
6. Attach the motor to the motor mounting.

**Tightening torque [Nm] of clamping screws**

Screw	SW	Torque
M6	5	14
M8	6	35
M10	8	65
M12	10	74

## 7 Commissioning

### WARNING



Risk of injury or damage to other installation parts due to quick linear movements of the transport devices due to centrifugal load.

Only authorised personnel are permitted to commission the linear unit.

### DANGER



Risk of crushing due to incorrect direction of movement of the transport devices.

Should the direction of rotation of the drive (motor or gear) and the sliding carriage drive (spindle or toothed belt) not correspond, the mounted transport devices may travel in the wrong direction. Around all rotating parts (e.g. GX shaft) there is a risk of being pulled in, and of clothing or body parts being caught up and trapped. There is also a risk of crushing around the moving carriage and the rack-and-pinion drive. These hazards can be countered by installing effective safety mechanisms that comply with the current standards and are state-of-the-art. These are not supplied with the linear unit and must be installed by the manufacturer of the overall installation.

Only qualified electricians are permitted to carry out any work on the electrical installation or check the direction of rotation.

### Checking the unit before commissioning

Before commissioning, the following must be checked:

- whether the holding devices used are consistent with the mass and acceleration information provided by the manufacturer,
- whether the machine or installation in which the linear unit is installed corresponds to the provisions set out by the machinery directive, the harmonised standards, the European or national standards,
- whether the linear unit is correctly mounted
- whether the inductive and/or mechanical limit switch is correctly connected and functioning properly.
- whether the direction of rotation of the motor shaft and, if applicable, the intermediary gear corresponds to the direction of rotation of the spindle or the toothed belt.

If there are faults detected during this inspection, commissioning is not permitted.

### Test run

To prevent accidents, collisions and possible errors in the programming, move the linear unit along the stroke several times at such a low speed that it can be stopped in good time in case of an emergency.

The installation can be started up after it has been ensured that there is no risk of a collision when exceeding the maximum stroke.

## 8 Operation

WARNING



The drive motor can heat up considerably during operation. In this case, refer to the operating instructions supplied for the drive motor.

CAUTION



Risk of damage due to harmful environmental influences! The linear unit may only be operated under environmental conditions which are permitted by the manufacturer.

### Environmental conditions

The linear unit may only be operated within the permitted temperature range of 0 - 80 °C.

Operating the unit in damp, abrasive conditions may result in foreign objects entering components in the linear unit. To prevent this, as part of the integration of the linear unit into the entire plant, measures may need to be taken to prevent foreign bodies from penetrating, e.g. using folding plates, baffle plates, sealing air.

### Required inspection

The linear unit must be occasionally checked during operation to see that it is functioning correctly.

The personnel responsible must check the linear unit and the machinery for any visible signs of damage or defects at least once during each shift.

Should there be any changes observed which may compromise safety, it must be switched off immediately.

### Emergency stop

The maximum permissible load values must not be exceeded even in an emergency stop situation.

As a rule, the category 1 emergency stop strategy (targeted braking to standstill, then de-energise) is chosen for automation equipment with moving masses. A simple emergency stop strategy is not usually effective, as the masses are still moving and can cause damage.

### End position damping

The end stops and stop buffers installed in our linear modules protect the unit at low speed (commissioning). They are definitely not intended to completely protect the unit against damage at high speed and/or with a large mass.

## 9 Decommissioning

WARNING



---

Risk of injury or damage to other installation parts due to falling parts. Only authorised personnel are permitted to disassemble the linear unit.

---

1. Separate the machine/installation from the mains supply.
2. Disassemble the drive from the linear unit.
3. Unscrew the linear unit from the machine/installation.

## 10 Maintenance

DANGER



---

Around all rotating parts (e.g. GX shaft) there is a risk of being pulled in, and of clothing or body parts being caught up and trapped. There is also a risk of crushing around the moving carriage and the rack-and-pinion drive.

For this reason, lubrication of the linear unit may only be carried out while it is moving slowly (max. 0.025 m/s), and for any cleaning work the linear unit drive must be shut down and secured against being restarted.

---

- All mounted ball bearings are sealed and maintenance-free.
- Remove excessive dust and dirt from the cover band and other parts of the linear unit regularly.

## 10.1 Lubrication

**Influencing factors** The following influencing factors are important for an accurate regulation of lubrication intervals:

- Load
- Speed
- Motion sequence
- Operating temperature
- Degree of contamination

**Short lubrication intervals** Short lubrication intervals are required for:

- operation under the influence of dust and dampness
- a heavy load
- high speed (up to  $V_{max}$ )

**Short strokes**  
 (Short stroke design) Short stroke refers to a stroke with a value equal to or lower than that specified in the table. To achieve the best possible lubrication, relubrication should be carried out from both sides with guiding carriage short strokes and thus requires a special attachment. (Design feasibility must be checked.)

A lubrication stroke should also be carried out at least once per shift (8 hours) where possible.

Größe	12	15	20	25	25L	30	30L	35	35L
THK	40	95	120	140	175	160	210	185	250
Bosch-Rex.	40	80	100	115	160	135	180	155	210
Lubrication stroke	70	130	160	180	220	210	260	240	300

### Initial lubrication

☛ After commissioning, carry out the initial lubrication. The basic lubrication has already been carried out by the manufacturer.

Refer to the lubrication regulations on the following pages.

**Lubrication points on linear units size 90 and 120**

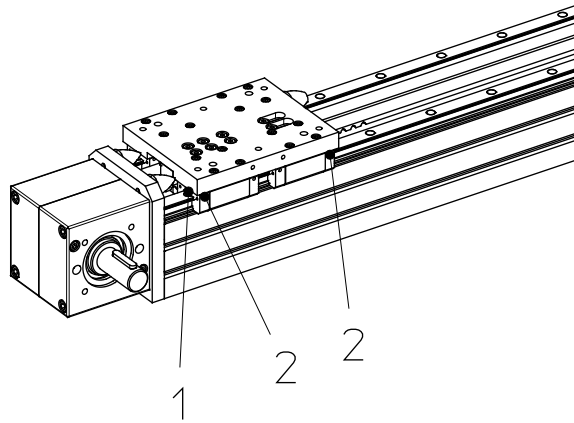
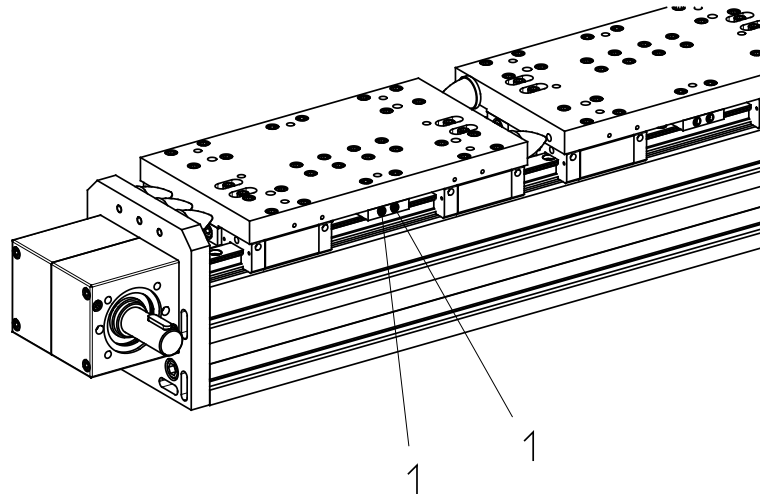

*Figure 4: Lubrication points (1) or (2) on carriage*

The lubrication points are located on the front faces (1) or on the sides (2) of the guide carriages (4 x per carriage). For size 120, the side lubrication point (2) is preferred as the two carriages can run very closely together and therefore a collision between the front face lubrication connections can occur.

The lubrication plan outlined below applies for the lubrication points.

**Size 160 to 280**



*Figure 5: Lubrication points (1) on the carriage*

The lubrication points (1) are on the two long sides of the carriage and each supply two guide carriages (meaning it is only possible to relubricate from one side).

The lubrication plan outlined below applies for the lubrication points.

**Lubrication method**

Lubrication should take place as far as possible while in motion so that the grease is distributed and no pressure builds up.

**Lubrication plan for lubrication point F**

Guide carriage size	Lubrication interval	Amount of grease [cm <sup>3</sup> ] per guide carriage	Type of grease
15 with ball chain	approx. 5,000 km*	approx. 0.4	Grease in accordance with DIN51825-KP2N-20, e.g. Klüberplex BE 31-102  ☛ Please take note of the instructions provided by the lubricant manufacturer should a different type of grease be used!  ☛ Grease with a solid lubricant component (e.g. graphite, MoS <sub>2</sub> ) is not to be used!
20 with ball chain		approx. 0.6	
25(L) with ball chain		approx. 1.2	
35 with ball chain		approx. 1.7	
15 without ball chain	approx. 2,000 km*	approx. 0.8	
20 without ball chain		approx. 1.4	
25(L) without ball chain		approx. 2.8	
35 without ball chain		approx. 4.4	

*\*Or at least twice a year. The lubrication interval depends on the environmental conditions and the load. Relubrication "in motion"!*

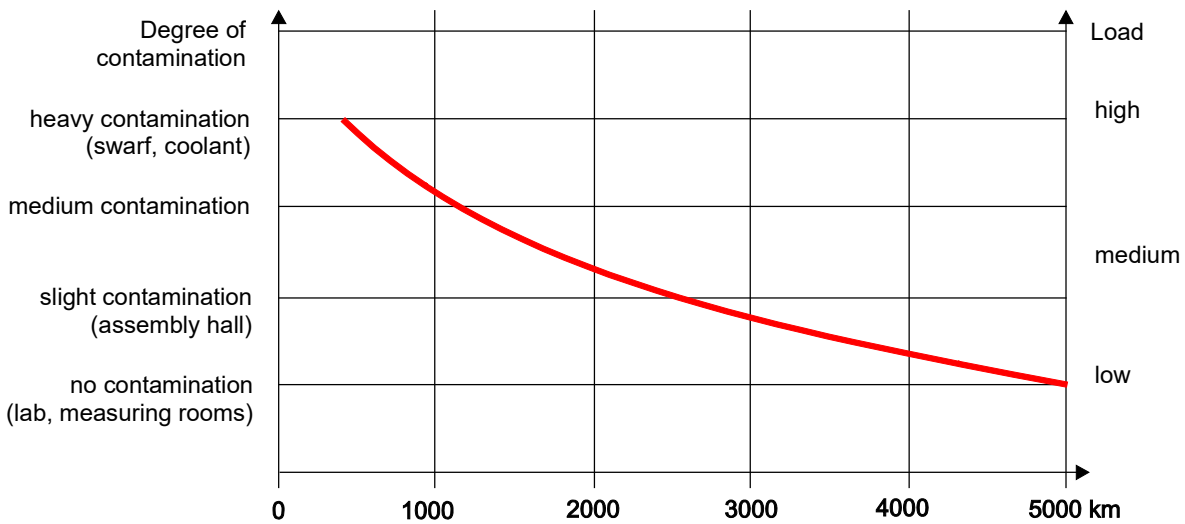
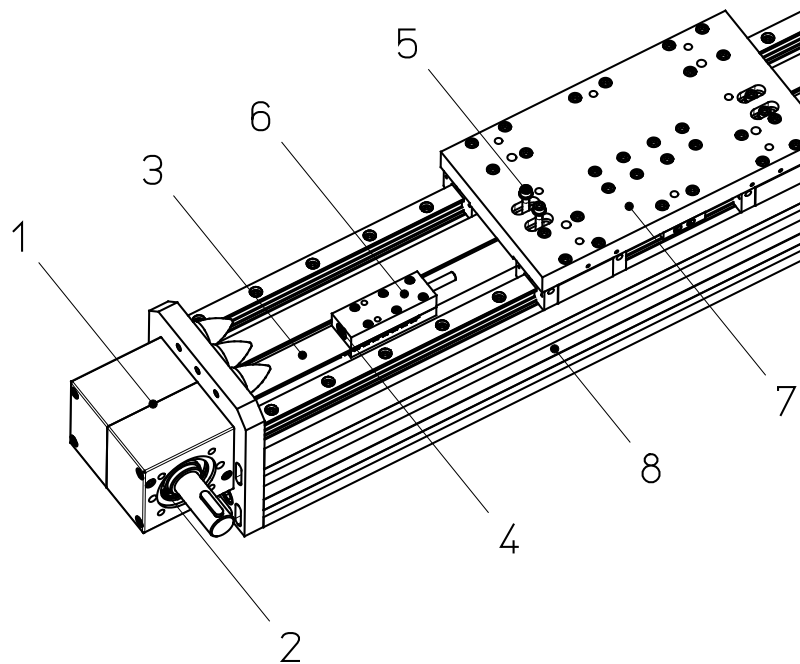

Figure 6: Relubrication intervals for the linear guide system with ball chain

## 10.2 Replacing the toothed belt

☛ For optimum functioning of the linear unit and to prevent damage during operation, it must be ensured during assembly that no foreign matter enters any parts of the linear unit.

☛ Do not damage the standard parts (screws, pins, etc.) as they will be used again.



Legend	1	Bearing housing cover plate	5	Clamping screw
	2	Synchronising disc	6	Toothed belt holder, compl.
	3	Toothed belt	7	Carriages
	4	Tensioning screws	8	Base profile

Figure 7: Replacing the toothed belt

1. Loosen the clamping screws (5) on the toothed belt holder (6).
2. Loosen the tensioning screws (4) on the toothed belt holder (6) on both sides of the sliding carriage (7).
3. Place both toothed belt holders on the basic profile (8).
4. Unscrew the clamping plate from the toothed belt holders (6 screws each).

5. Attach one end of the new toothed belt to the end of the old toothed belt (3) using adhesive tape making it easier to pull into the drive housing.

☛ When sticking the two ends together, the tooth pitch of both belts must correspond to enable the new toothed belt to engage with the synchronising disc (2).

6. Take hold of the other free end of the defective toothed belt and pull both toothed belts slowly through the drive housing (1). The new toothed belt can be easily fed and thus pulled into the housing.
7. Mount the toothed belt holders to both ends of the new toothed belt.
8. Secure the toothed belt holders to the carriage again in the opposite order using the tensioning and clamping screws but do not tension the toothed belt. (Note: The tensioning screws must be secured with Loctite 243).
9. Now tension the toothed belt.
10. Set the required tension accurately using a belt tensioning measurement device (See Operating Instructions for the measurement device).

☛ Only the required tension which is correctly set will guarantee optimal operation of the unit.

11. The measurement position and the Hz figure applicable for the toothed belt are supplied with the replacement toothed belt. Tension the toothed belt in such a way that the Hz figure given is shown.
12. Tighten the clamping screws.

### 10.3 Your added value in service: Repair and Retrofit

In addition to installation and maintenance, we also offer professional repair and retrofit services for our products. You benefit from our expertise, fast fault diagnosis, and expert repairs – helping to extend the service life of your products and modernize existing systems.

For further information regarding repairs or retrofit solutions, please contact our customer service at [service.greifsysteme@de.schunk.com](mailto:service.greifsysteme@de.schunk.com).

We will be happy to advise you.