

## Original Assembly and Maintenance Manual

Linear Unit

**HSB**-beta®

Types

Beta 40-SGS-SSS

Beta 50-C-SRS

HSB Automation GmbH  
In Laisen 74  
72766 Reutlingen  
Germany  
Tel. +49 7121 14498-0  
info@HSB-Automation.de  
www.HSB-Automation.de

Distributor:  
SCHUNK GmbH & Co. KG  
Spann- und Greiftechnik  
Bahnhofstr. 106 - 134  
74348 Lauffen/Neckar  
Germany  
Tel. +49 7133-103-0  
Fax +49 7133-103-2399  
info@de.schunk.com  
www.schunk.com



## Contents

<b>1</b>	<b>Safety</b> .....	<b>2</b>
1.1	Symbols used .....	2
1.2	Regulation use .....	2
1.3	General safety .....	3
1.5	Use in explosive areas.....	3
1.6	Technical condition of the linear unit.....	3
1.7	Modifications to the linear unit .....	4
1.8	Requirements for personnel.....	4
1.9	Responsibilities of the operator.....	4
<b>2</b>	<b>Warranty</b> .....	<b>5</b>
<b>3</b>	<b>Technical data – Standard model</b> .....	<b>6</b>
<b>4</b>	<b>Product description</b> .....	<b>9</b>
<b>5</b>	<b>Transportation and storage</b> .....	<b>11</b>
<b>6</b>	<b>Installation and adjustment</b> .....	<b>12</b>
6.1	Installing the linear unit by mounting rails .....	12
6.2	Screwing the linear unit into place from below .....	13
6.3	Setting maximum travel .....	14
6.3.1	Setting the positions of the inductive limit switches .....	14
6.3.2	Setting the positions of the mechanical limit switches.....	16
6.4	Mounting a drive unit .....	18
6.4.1	Mounting a motor .....	18
<b>7</b>	<b>Start-up</b> .....	<b>20</b>
<b>8</b>	<b>Operation</b> .....	<b>21</b>
<b>9</b>	<b>Shutdown</b> .....	<b>22</b>
<b>10</b>	<b>Maintenance</b> .....	<b>22</b>
10.1	Lubrication.....	23
10.2	Replacing cover bands .....	27
10.3	Your added value in service: Repair and Retrofit.....	29

# 1 Safety

The Assembly and Maintenance Manual is a component element of the product package, and must always be kept to hand as a reference source.

The Manual must be passed on if the unit is sold on or given away.

If there is anything in this manual which you do not fully understand, please be sure to contact the manufacturers.

## 1.1 Symbols used

This Assembly and Maintenance Manual employs the following symbols to indicate hazards as well as other types of symbol:

DANGER



Indicates immediate danger.

Failure to observe this notice entails risk of death or very serious injury.

WARNING



Indicates a danger carrying a medium to high risk.

Failure to observe this notice may result in death or serious injury.

CAUTION



Indicates minor risk.

Failure to observe this notice may result in light to moderate injury or damage to property.

 Note

Indicates tips on use of the machine and optimising its efficiency.

## 1.2 Regulation use

The mechanical linear unit is intended for installation in machines, and is used solely for manipulating, positioning, transporting, palletising, loading, unloading, clamping, clocking, tensioning, testing, measuring, handling and pushing workpieces or tools.

Pay attention to the basic applications of the linear unit set out in sections 4 and 3.

In order to comply with the EU Directive governing Electromagnetic Compatibility (EMC), the mechanical linear unit may only be used in industrial environments.

Any other use, or use for purposes beyond those stipulated, will be classed as illegitimate. The manufacturers accept no liability for any loss thereby incurred. The risk is borne solely by the operators.

## 1.3 General safety

<b>Preconditions for operation</b>	The linear unit must not be put into operation until the machine or line into which it is installed conforms to the following: <ul style="list-style-type: none"> <li>• EC/EU directives</li> <li>• Standards governing the electromagnetic compatibility of machinery</li> </ul>
<b>Safe operation</b>	To ensure safe operation, refer to the following documents: <ul style="list-style-type: none"> <li>• This operating manual for the linear unit, particularly the technical data</li> <li>• The operating manual for the line into which it is installed</li> </ul>
<b>Decommissioning</b>	Dispose of the product in accordance with the applicable national requirements. Observe the safety data sheets.

## 1.4 Use in clean rooms (ISO 14644)

The linear units used in clean rooms are fitted with a vent hole (generally G1/4") at the basic profile.

The following guidelines must be observed:

- The linear unit must be subjected to a negative pressure of 0.2 bar.
- The linear unit must be relubricated with a grease suitable for use in clean rooms (basic lubrication carried out using Klübersynth BEM 32-34).

## 1.5 Use in explosive areas



The linear units are suitable for use in explosive atmospheres in zones according to their ATEX marking. In addition to these assembly and maintenance instructions, the document "[FM\\_319\\_Use-in-Atex-zones-MuW](#)" must also be observed.

## 1.6 Technical condition of the linear unit

<b>State of the art</b>	The unit conforms to the current state of the art and applicable rules and regulations. The device complies with the EC Machinery Directive and the relevant Harmonised Standards (European standards). Furthermore, the EC Declaration of Incorporation applies.
-------------------------	---

## 1.7 Modifications to the linear unit

### Modifications

The linear unit must not be modified, either in its basic design or in its safety components, without our written consent. Any such unauthorised modification will void our liability in respect of the unit.

The operating company may only carry out the maintenance and repair work detailed in this operating manual. Any other measures, such as to replace wearing parts and components, may be carried out only in consultation with our service engineers, by the service engineers themselves, or by us directly.

Installed safety devices must never be dismantled or disabled.

When fitting special attachments to the unit, follow the fitting instructions provided by the manufacturers!

## 1.8 Requirements for personnel

Work on parts carrying live electrical current may be carried out only by trained electricians. Such work includes:

- Installing safety limit switches
- Mounting a drive unit
- Checking the direction of rotation of the drive

## 1.9 Responsibilities of the operator

**Preservation of labels** The operator must ensure that any lettering, information signs or labels are fully legible (in particular the serial number) and always observed. Any damaged or illegible information signs and labels must be replaced.

**Accident Prevention and Environmental Protection** The applicable regulations for accident prevention and environmental protection must be observed.

**Disposal** Dispose of the product according to the relevant national regulations. Refer to the safety data sheets.

## 2 Warranty

The warranty conditions are laid down in the terms and conditions of delivery and payment issued at time of order. Warranty cover will be voided if:

- the unit is not operated in accordance with the stipulated regulation use;
- the instructions set out in this operating manual are not followed;
- the unit is modified without the consent of the manufacturers;
- screws sealed by locking varnish are unlocked.

The manufacturer's warranty in respect of maintenance and repair work applies only if original replacement parts are used.

### 3 Technical data – Standard model

Technical data - Linear unit Beta type with spindle drive	Sizes					
	Beta 40				Beta 50-C	
	SGS		SSS		SRS	
Drive element	KGT <sup>2)</sup>	TGT <sup>3)</sup>	BSD	TSD	BSD	TSD
Max. speed [rpm]	3000	1500	3000	1500	3000	1500
Spindle diameter [mm]	12				12	
Spindle pitch [mm]	5 10	3	5 10	3	5 10	3
Moment of inertia [kgm <sup>2</sup> /m]	1.20 x 10 <sup>-5</sup>				1.20 x 10 <sup>-5</sup>	
Max. velocity <sup>1)</sup> [m/s]	0,25				0,25	
Max. acceleration [m/s <sup>2</sup> ]	20				20	
No-load torque [Nm]	0,30		0,40		0,30	
Maximum travel (standard) [mm]	890		890		860	
Repeat accuracy [mm]	±0,03		±0,03		±0,03	
Operating temperature [°C] (continuous operation)	0 ... 80		0 ... 80		0 ... 80	
Geometrical moment of inertia I <sub>y</sub> [mm <sup>4</sup> ]	88914				235424	
Geometrical moment of inertia I <sub>z</sub> [mm <sup>4</sup> ]	133632				294804	
Length of standard carriage [mm]	120				150	
Length of long carriage [mm]	200				200	
Weight (without travel) [kg]	1,50		1,70		1,50	
Weight (per 100 mm travel) [kg]	0,30		0,40		0,40	
Weight of standard carriage [kg]	0,30		0,40		0,45	
Weight of long carriage [kg]	0,50		0,65		0,60	
Noise emission max. [dB A] <sup>4)</sup>	80		80		80	

<sup>1)</sup> *Dependent on spindle pitch at max. speed*

<sup>2)</sup> *Ball Screw Drive*

<sup>3)</sup> *Trapezoidal Screw Drive*

<sup>4)</sup> *The figure will vary based on assembly with other system components*

	<b>Forces and moments - Beta linear unit with spindle drive</b>							
	<b>Dynamic forces [N]</b>				<b>Dynamic moments [Nm]</b>			
<b>Type designation</b>	<b>F<sub>X</sub></b>	<b>F<sub>Y</sub></b>	<b>F<sub>Z</sub></b>	<b>-F<sub>Z</sub></b>	<b>M<sub>X</sub></b>	<b>M<sub>Y</sub></b>	<b>M<sub>Z</sub></b>	<b>M<sub>no-load</sub></b>
Beta 40-SGS	1000	80	150	75	6	6	8	0,3
Beta 40-SSS	1000	500	600	300	12	30	30	0,3
Beta50-C-SRS	1000	300	600	400	30	60	50	0,3

Figures in ( ) relate to the long carriage.

$M_{no-load}$  = No-load torque  $\pm 30\%$

The forces and moments quoted are maximum values for the single load. In the event of combined loading or simultaneous occurrence of multiple moments or forces, the individual values must be reduced. In case of doubt consult Technical Support.

### Dynamic load ratings of ball screw drives - Beta linear unit

Model and size	Nominal $\varnothing$ in [mm]	Pitch in [mm]	$C_{dyn}$ [N]
Beta 40 Beta 50 C	12	4	3400
		5	4400
		40	14900

Dynamic load rating of ball screw nut to DIN 69051, 1989

### Dynamic load ratings of rail guides - Beta linear unit

Model	Size	Number of rails	Number of carriages	Load rating per carriage $C_{dyn}$ [N] THK / Rex*	Pre-tension $F_v$ [N] THK / Rex*	$M_t$ [Nm] THK / Rex*	Guide spacing in direction x (lx1) [mm]	Guide spacing in direction y (ly) [mm]
Beta 40	12	1	2	3175 / 2310	-	25 / 14	83 (163)	-

Figures in ( ) relate to the long carriage

The load rating and pre-tension figures relate to the standard linear guidance system with recirculating linear ball bearings

\* Rex = Rexroth

Tightening torques [Nm] for fixing screws							
<b>Fixing screws</b>	<b>M4</b>	<b>M5</b>	<b>M6</b>	<b>M8</b>	<b>M10</b>	<b>M12</b>	The figures given are intended as guides. For shorter insertion depths, the figures must be adjusted accordingly.
DIN912/ISO4762-8.8	2,7	5,4	9,0	22,0	43,0	74,0	
DIN912/ISO4762-10.9	3,0	5,7	9,0	22,0	43,0	74,0	
DIN912/ISO4762-12.9	3,0	5,7	9,0	22,0	43,0	74,0	

Tightening torques [Nm] for clutch with clamping hub					
<b>Size</b>	<b>14</b>	<b>19</b>	<b>24</b>	<b>28</b>	<b>38</b>
Clutch diameter [mm]	30	40	55	65	80
Screw size	M3	M6	M6	M8	M8
Tightening torque [Nm]	1,34	10,50	10,50	25,00	25,00

Tightening torques [Nm] for clutch with clamping ring hub					
<b>Size</b>	<b>14</b>	<b>19</b>	<b>24</b>	<b>28</b>	<b>38</b>
Clutch diameter [mm]	30	40	55	65	80
Screw size	M3	M4	M5	M5	M6
Tightening torque [Nm]	1,34	2,90	6,00	6,00	10,00

## 4 Product description

### Linear unit with spindle drive

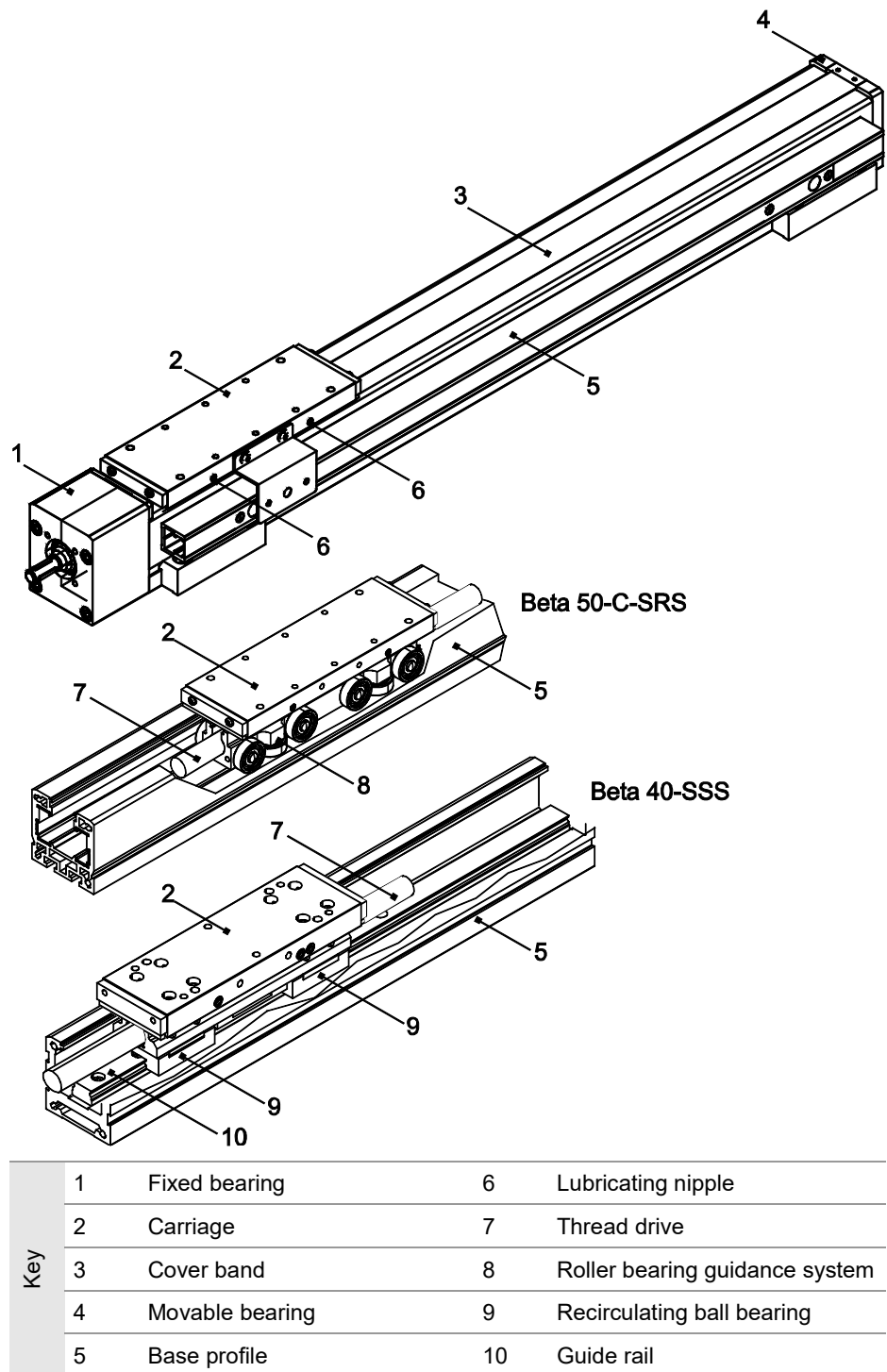

Figure 1: Component assemblies of the Beta 40 and Beta 50-C linear unit with spindle drive

A mechanical linear unit converts rotational motion into linear motion and is used to move loads quickly, safely and precisely from one position to another. It consists of an aluminium base profile, a moving carriage supported by a guide element (recirculating ball bearing or roller bearing guidance system) and a drive element (screw or timing belt drive).

Depending on its design, the carriage is able to absorb forces and moments in all directions, and is positively connected to the guidance and drive elements by way of the so-called drivers.

The base profile is self-supporting up to a certain length, and is equipped with grooves for mounting.

As an option, the linear unit can be equipped with accessories such as a cover, screw supports, inductive or mechanical limit switches and other fittings (see section **6.3**).

The effective range can be flexibly configured. Multiple linear units of the Alpha, Beta or Delta type can be arranged two-dimensionally (2 axes) or three-dimensionally (3 axes).

Driven linear units can be connected to non-driven units of the same type by a plate, to be able to take large-area loads for example.

## 5 Transportation and storage

The mechanical linear unit is a precision item. Its mechanism may be damaged by heavy jolting, resulting in impairment of its functions.

CAUTION



---

Risk of damage by heavy jolting or bending!

Transport the assembled linear unit only with the transit protection fitted.

---

To prevent damage during transportation and storage, protect the linear unit against shaking and sliding as follows:

- Stow it in a box of sufficient size.
- Use packing.

Section 3 lists the unit weights.

Protect the unit against:

- dirt;
- corrosion;
- water;
- and aggressive atmospheres.

## 6 Installation and adjustment

The linear unit can be attached by the following methods:

- On mounting rails
- By screws inserted into the sliding blocks
- By screws inserted into the factory-fitted tapped hole rails

☛ Install the linear unit on a flat surface. Unit parallelism < 0.2 mm/1,000 mm.

☛ Mounting by the rails with tapped holes in them is the preferable solution:  
for highly dynamic applications;  
where the linear unit has only two attachment points.

### 6.1 Installing the linear unit by mounting rails

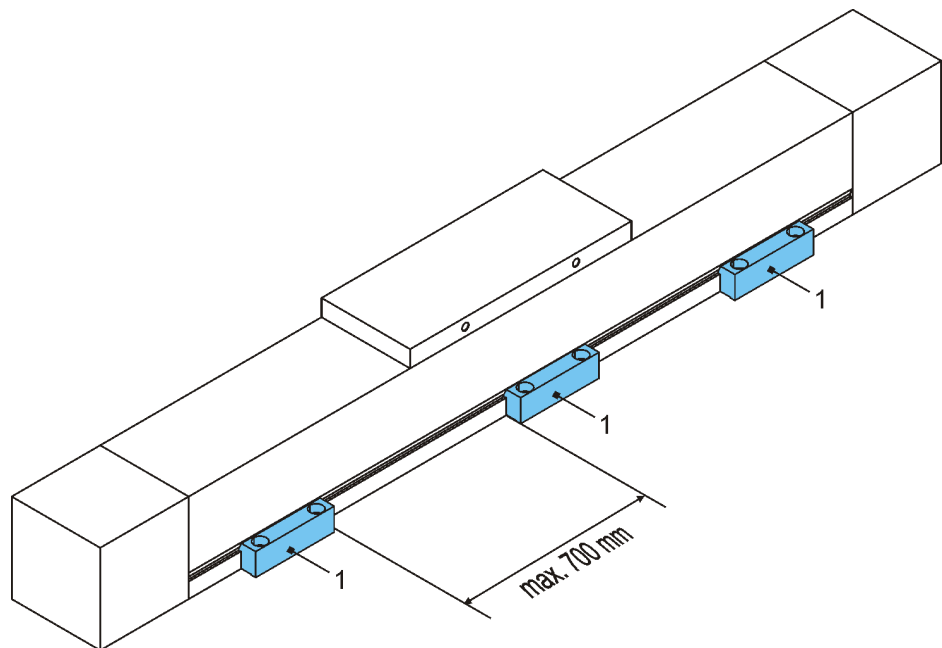

Figure 2: Mounting rails (1)

☛ The recommended maximum spacing between the mounting rails is 700 mm.

#### Procedure

1. Attach the mounting rails (1) loosely in position (Figure 2).
2. Align the linear unit axially.
3. Tighten the mounting rails (1)  
(for tightening torques see section 3).

## 6.2 Screwing the linear unit into place from below

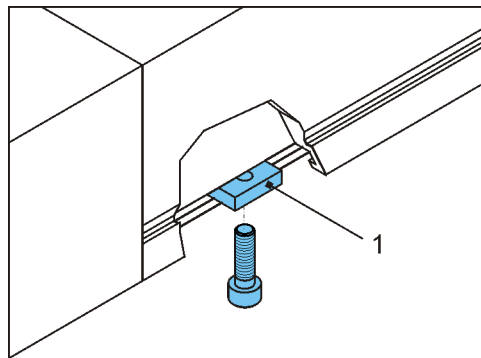

Figure 3: Sliding blocks (1) in the groove on the underside of the base profile

Attach the linear unit by the fixing screws from below using the sliding blocks or the tapped hole rails in the aluminium base profile (Figure 3).

### Procedure

1. Align the linear unit.
2. Align the sliding blocks (1)/tapped hole rails.
3. Tighten the linear unit  
(for tightening torques see section 3).

### 6.3 Setting maximum travel

DANGER



Serious injury may result if the transport carriers topple over. If the carriage moves to its full extent beyond the safety zone, the transport carrier mounted on it may break away or topple over. The linear unit may be destroyed. During setup, observe the specified safety zone and set the limit switches accordingly. Electrical switches may only be connected by qualified electricians.

☛ To stop the carriage promptly in the event of an emergency stop, allow for adequate braking distance.

#### 6.3.1 Setting the positions of the inductive limit switches

The function of inductive proximity switches is to shut down the electric drive before the mechanical end position is reached.

The necessary braking distance ( $\Delta B$ ) depends on the velocity and deceleration of the carriage. The braking distance must be between the switching point of the proximity switch and the actual mechanical end position.

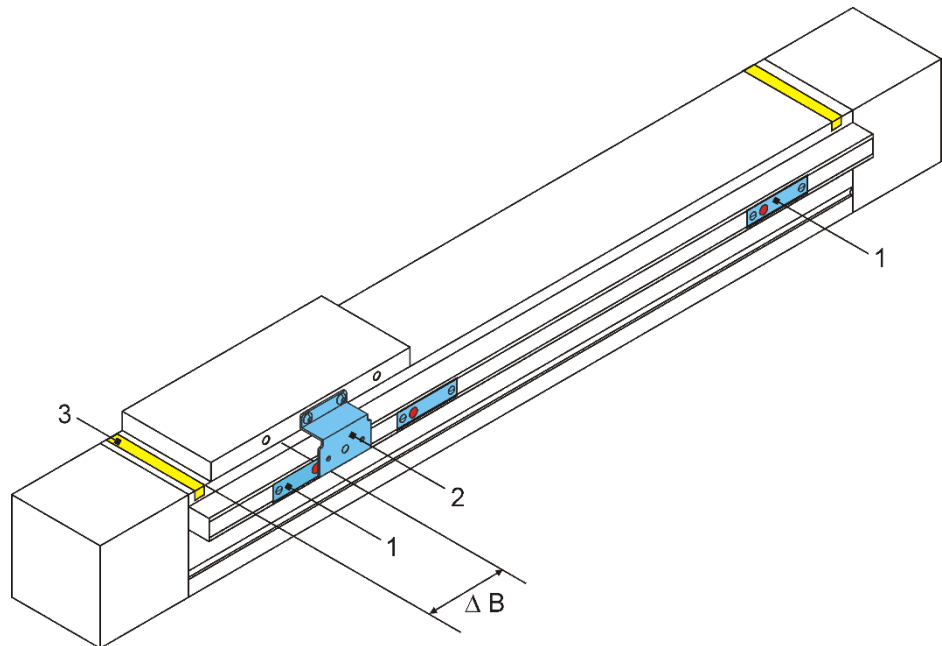

Key	1	Inductive limit switch
	2	Switching cam
	3	Band marking safety zone

Figure 4: Inductive limit switches

**CAUTION**



---

The limit switches must switch so that the carriage comes to a stop immediately before the safety zone. The safety zone is factory-marked on the unit by a band (3).

---

**Procedure**

1. Connect the power to the limit switches.
2. Slacken the limit switch fixing screws.
3. Run the carriage as far as the braking position.
4. Move the limit switch (NC contact) under the switching cam until it trips and the LED on the sensor goes out.
5. Move the carriage away.
6. Tighten the limit switch.
7. Check the correct position of the limit switch: Move the carriage manually and observe the switching operation.
8. Fit the limit switch array covering.

### 6.3.2 Setting the positions of the mechanical limit switches

Mechanical safety limit switches (NC contacts) must be used if a hazard is posed to personnel as soon as the electric drive fails to shut down.

The drive may only be started up when all limit switches are connected and correctly set!

A combination with inductive proximity switches is possible.

External shock-absorbers must be fitted to protect against mechanical destruction.

The necessary braking distance ( $\Delta B$ ) depends on the velocity and deceleration of the carriage. The braking distance must be between the switching point of the limit switch and the actual mechanical end position (Figure 5).

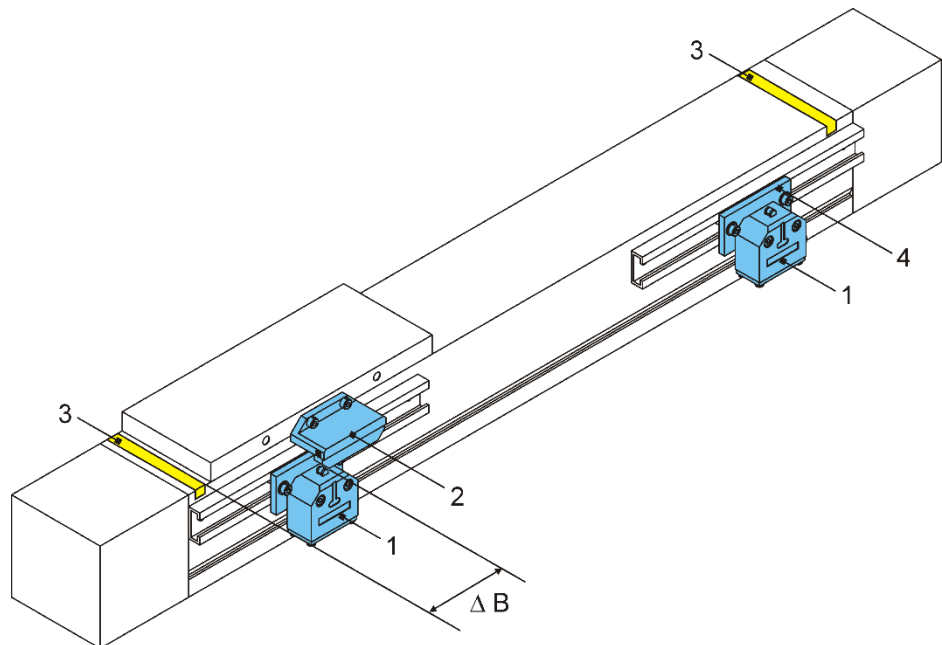

Key	1	Mechanical limit switches
	2	Switching cam
	3	Band marking safety zone
	4	Bracket
	B	Braking distance

Figure 5: Mechanical limit switches

CAUTION



The limit switches must switch so that the carriage comes to a stop immediately before the safety zone. The safety zone is factory-marked on the unit by a band (3).

**Procedure**

1. Connect the power to the limit switches.
2. Slacken the bracket fixing screw (Figure 5).
3. Run the carriage as far as the safety zone.
4. Move the limit switch until it trips.
5. Tighten the bracket fixing screw.
6. Check the correct position of the limit switch: Move the carriage manually and observe the switching operation.  
If the braking distance is too short, repeat the set-up.

## 6.4 Mounting a drive unit

Make sure the direction of rotation of the external drive unit takes into account the direction of the spindle or timing belt so that the limit switches work correctly.

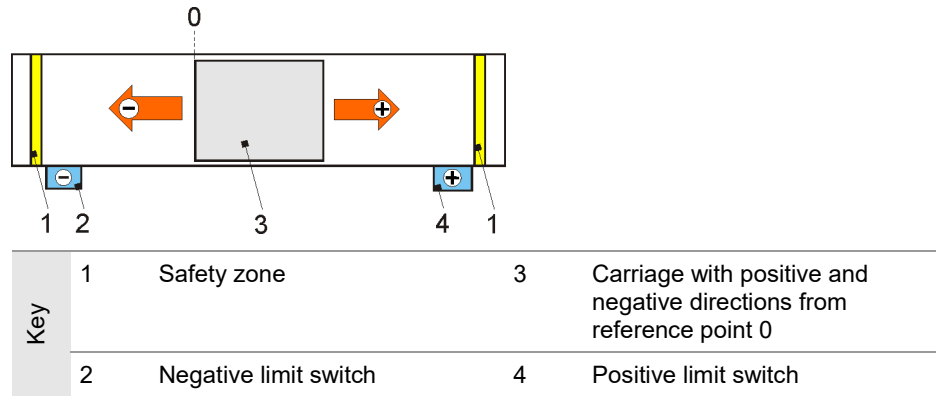

Figure 6: Example of travel direction and limit switch configuration

### 6.4.1 Mounting a motor

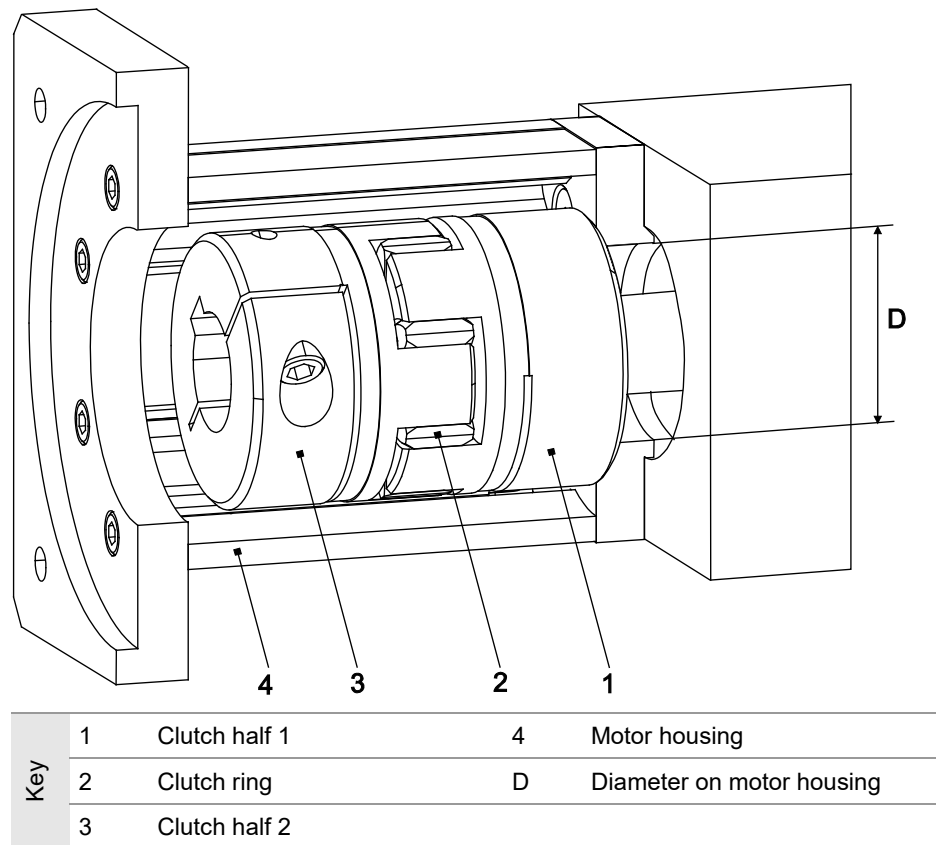

Figure 7: Motor housing with motor clutch on drive pin

## Procedure

1. Place the motor and the clutch components in mounting position adjacent to the linear unit.
2. Check the direction of rotation of the motor. It must take into account the safety limit switches (Figure 6). Alter the direction of the motor as necessary.
3. If the clutch diameter is less than the measure D on the motor housing (4), first mount clutch half 1 (1) (hole flush with drive shaft) and then the motor housing (4) (Figure 7).

If the clutch diameter is greater than the measure D on the motor housing (4), first mount the motor housing (4) and then the clutch half 1 (1) (hole flush with drive shaft). Tighten the clutch clamping screw through the mounting hole on the motor housing (4).

4. Slot the clutch ring (2) onto the clutch.
5. Mount clutch half 2 (3) on the motor pin.
6. Mount the motor on the motor housing.

### Tightening torque [Nm] of clamping screws

Screw	SW	Torque
M6	5	14
M8	6	35
M10	8	65
M12	10	74

## 7 Start-up

### WARNING



Risk of personal injury or damage to other system components caused by rapid linear motion of the transport carrier, caused by thrown loads.  
Only authorised specialist personnel may start up the linear unit.

### DANGER



Risk of crushing due to incorrect direction of movement of the transport devices.  
Should the direction of rotation of the drive (motor or gear) and the sliding carriage drive (spindle or toothed belt) not correspond, the mounted transport devices may travel in the wrong direction. Around all rotating parts, e.g. GX shaft and around the toothed belt (when used without cover band), there is a risk of being pulled in, and of clothing or body parts being caught up and trapped. There is also a risk of crushing around the moving carriage. These hazards can be countered by installing effective safety mechanisms that comply with the current standards and are state-of-the-art. These are not supplied with the linear unit and must be installed by the manufacturer of the overall installation.  
Use of the deflection belt drive without the protective hood supplied is not permitted.  
Only qualified electricians may carry out the electrical installation and check the direction of rotation.

### Checks before start-up

Before starting the unit, check the following:

- Make sure the retaining fixtures conform to the mass and acceleration data provided by the manufacturers.
- Make sure the machine or line into which the linear unit is installed conforms to the EU Machinery Directive, the harmonised European standards or applicable national standards.
- Make sure the linear unit is correctly installed.
- Make sure the inductive and/or mechanical limit switches are correctly connected and working properly.
- Make sure the direction of rotation of the motor shaft and - where appropriate - of the interposed gearbox - matches that of the spindle or timing belt.

If the checks reveal any defects, prohibit start-up of the unit.

### Trial run

To prevent accidents, collisions and possible errors in the programming, move the linear unit along the stroke several times at such a low speed that it can be stopped in good time in case of an emergency.

The line may be started up once it has been established that there is no risk of collision when the maximum travel is overrun.

## 8 Operation

### WARNING



The drive motor can heat up considerably during operation. In this case, refer to the operating instructions supplied for the drive motor.

### CAUTION



Risk of damage from harmful environmental influences! Operate the linear unit only under the ambient conditions approved by the manufacturers.

### Ambient conditions

The linear unit may only be operated within the permitted temperature range of 0 - 80 °C.

Operating the unit in damp, abrasive conditions may result in foreign objects entering components in the linear unit. To prevent this, as part of the integration of the linear unit into the entire plant, measures may need to be taken to prevent foreign bodies from penetrating, e.g. using folding plates, baffle plates, sealing air.

### Duty of inspection

The proper functioning of the linear unit must be checked periodically during operation.

The responsible personnel must check the linear unit and the line for external signs of damage and defects at least once every shift.

If changes occur which are detrimental to safety, shut down the line immediately.

### Emergency stop

The maximum permissible load values must not be exceeded even in an emergency stop situation.

As a rule, the category 1 emergency stop strategy (targeted braking to standstill, then de-energise) is chosen for automation equipment with moving masses. A simple emergency stop strategy is not usually effective, as the masses are still moving and can cause damage.

### End position damping

The end stops and stop buffers installed in our linear modules protect the unit at low speed (commissioning). They are definitely not intended to completely protect the unit against damage at high speed and/or with a large mass.

## 9 Shutdown

### WARNING



---

Risk of personal injury or damage to other system components caused by falling system components.  
Only authorised specialist personnel may disassemble the linear unit.

---

1. Cut the power to the machine/line.
2. Dismantle the drive from the linear unit.
3. Detach the linear unit from the machine/line.

## 10 Maintenance

### DANGER



---

Around all rotating parts, e.g. GX shaft and around the toothed belt (when used without cover band), there is a risk of being pulled in, and of clothing or body parts being caught up and trapped. There is also a risk of crushing around the moving carriage.

For this reason, lubrication of the linear unit may only be carried out while it is moving slowly (max. 0.025 m/s), and for any cleaning work the linear unit drive must be shut down and secured against being restarted.

---

- All installed ball bearings are sealed and maintenance-free.
- Remove excessive dust and dirt from the cover band and other components of the linear unit on a regular basis.
- Relubricate the thread drives of the linear axes on a regular basis.

## 10.1 Lubrication

### Influencing factors

The following factors are key to determining the exact lubrication intervals required:

- Loading
- Velocity
- Motion
- Operating temperature
- Degree of dirtying

### Short lubrication intervals

Short lubrication intervals are required for:

- operation under the influence of dust and dampness
- a heavy load
- high speed (up to  $V_{max}$ )

### Short strokes (Short stroke design)

Short stroke refers to a stroke with a value equal to or lower than that specified in the table. To achieve the best possible lubrication, relubrication should be carried out from both sides with guiding carriage short strokes and thus requires a special attachment. (Design feasibility must be checked.)

A lubrication stroke should also be carried out at least once per shift (8 hours) where possible.

Größe	12	15	20	25	25L	30	30L	35	35L
THK	40	95	120	140	175	160	210	185	250
Bosch-Rex.	40	80	100	115	160	135	180	155	210
Lubrication stroke	70	130	160	180	220	210	260	240	300

*Not feasible with Beta 40-SS*

In addition, it must be ensured that the stroke is at least (2x) the length of the ball screw nut. If this is not the case, consultation is mandatory.

### Initial lubrication

☛ Carry out an initial lubrication after starting up the unit for the first time. A basic lubrication was applied at the factory.

Refer to the lubrication regulations on the following pages.

### Note

Under normal operating conditions (dry environment, no dusts, etc.), the roller guide is lubricated for life with integrated lubricating felts.

**Lubrication points on linear units**

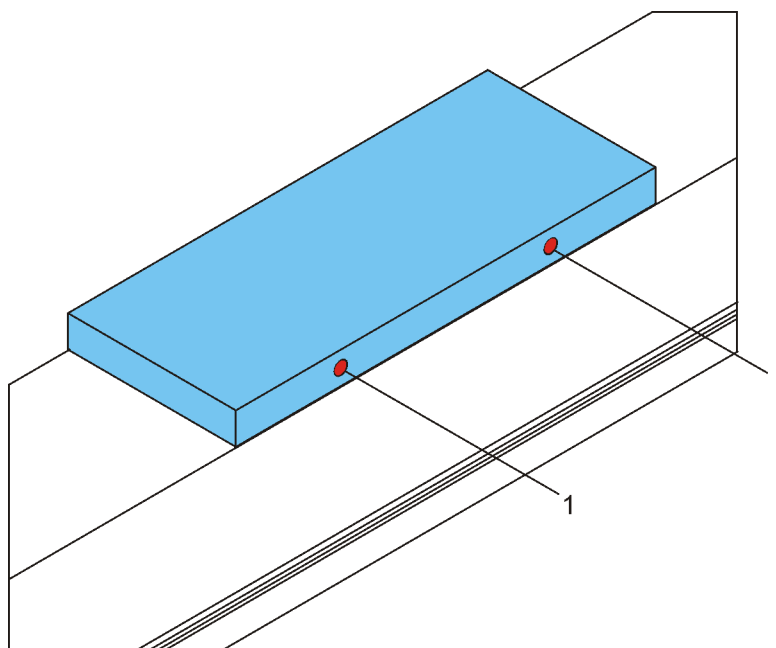

Figure 8: Possible lubrication points (1) on the carriage

The categories, quantity and positions of lubrication point depend on the model of linear unit. The categories of lubrication point are identified by the markings S, F on the unit. There is a separate lubrication schedule for each lubrication point category.

Lubrication point category	Lubrication for...	Lubricant
S	Spindle	Grease
F	Guide elements	Grease

**Lubrication method**

Lubrication should, as far as possible, take place while the unit is running, so that the grease is distributed evenly and no pressure is built up.

**Schedule for lubrication point S (for ball screw drive)**

BSD* type	Lubrication intervals at roll-overs	Grease quantity [cm <sup>3</sup> ] per ball screw nut	Grease type
1204	25.000.000**	0,50	Greases to DIN 51825-KP2N-20, e.g. Klüberplex BE 31-102  ☛ If other greases are used, pay attention to manufacturers' specifications!  ☛ Greases containing solid lubricant (e.g. graphite, MoS <sub>2</sub> ) must not be used!
1205		0,55	
1605		1,70	
1610		1,80	
1620		1,90	
2005		2,00	
2020		2,30	
2050		4,50	
2505		2,60	
2510		3,40	
2525		3,10	
2550		4,80	
3205		4,20	
3210		13,10	
3220		8,40	
3232		5,30	
3240		3,00	
4005	15.000.000**	5,30	
4010		15,40	
4020		10,20	
4040		9,50	

\*BSD = Ball Screw Drive  
 \*\* Or at least 2x per year. The lubrication interval depends on the ambient temperatures and on the loading (see figure 9). Relubrication "in motion"!

**Schedule for lubrication point F (for linear guide)**

Carriage size	Lubrication interval	Grease quantity [cm <sup>3</sup> ] per carriage	Grease type
15 with ball chain	approx. 5,000 km*	ca. 0.4	Greases to DIN 51825-KPE1R-20, e.g. Klüberplex BE 31-102  ☛ If other greases are used, pay attention to manufacturers' specifications!  ☛ Greases containing solid lubricant (e.g. graphite, MoS <sub>2</sub> ) must not be used!
20 with ball chain		ca. 0.6	
25(L) with ball chain		ca. 1.2	
30 with ball chain		ca. 1.5	
35 with ball chain		ca. 1.7	
12 with ball chain		ca. 0.14	
12 without ball chain	approx. 2,000 km*	ca. 0.15	
15 without ball chain		ca. 0.8	
20 without ball chain		ca. 1.4	
25(L) without ball chain		ca. 2.8	
30 without ball chain		ca. 4.4	
35 without ball chain	ca. 4.4		

\* Or at least 2 x per year. The lubrication interval depends on the ambient temperatures and on the loading (see figure 9). Relubrication "in motion"!

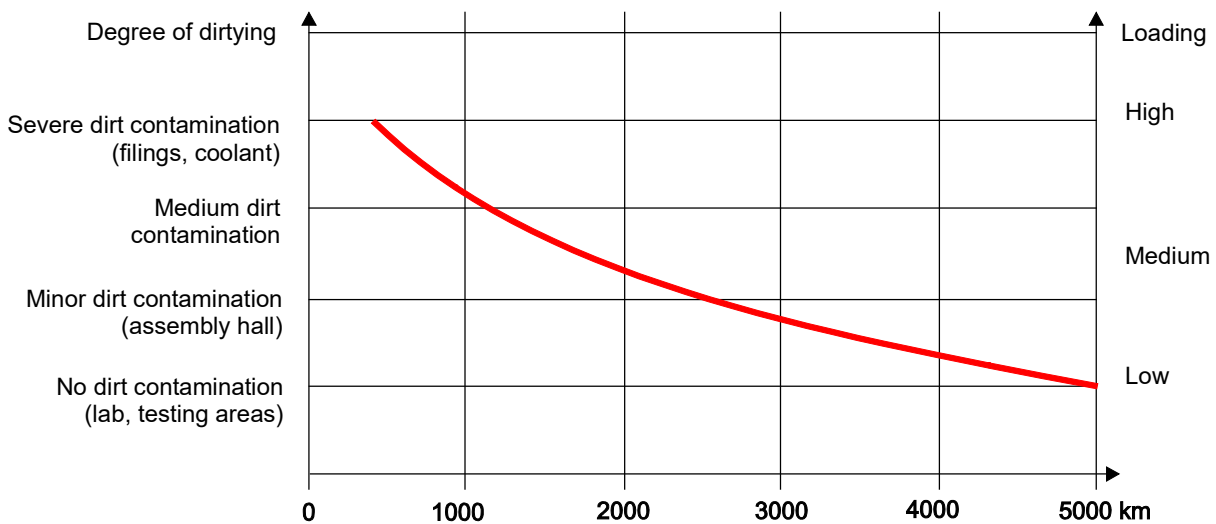

Figure 9: Relubrication intervals for the linear guidance system with recirculating linear ball bearings

## 10.2 Replacing cover bands

☛ To preserve the optimum running of the linear unit and prevent it from being damaged during operation, take care that no foreign bodies penetrate the base profile or other linear unit components during installation and assembly.

☛ Do not damage the standard parts (screws, pins, etc.) or the dismantled components; they will be refitted.

☛ If cover bands are worn, also replace the band guide elements. If cover bands are damaged, check the band guide elements for wear and replace them only as necessary.

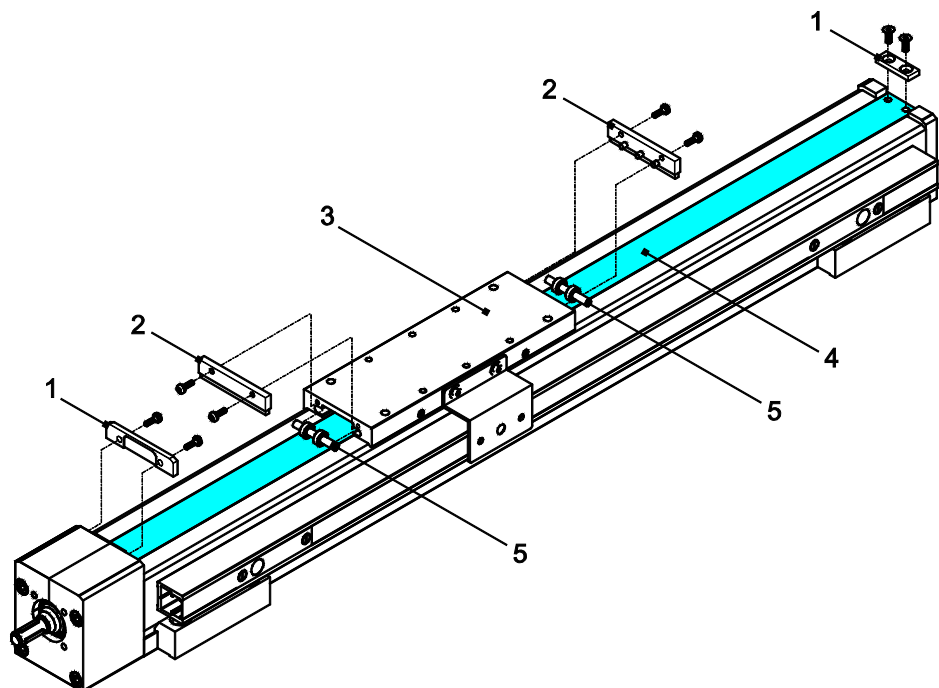

Key	1	Clamp fittings
	2	Stripper brushes
	3	Driver
	4	Cover band
	5	Band hold-down device

Figure 10: Cover bands based on the example of the Beta 50-C-SxS linear unit

**Procedure**

1. Move the driver into the middle.
2. Unfasten the stripper brushes (if fitted) from both front faces.
3. Detach the clamp fittings from the ends of the cover band and pull the cover band out of the driver.
4. Pull the press rollers (a) on both front faces of the driver out of the clamp (using a hook).
5. Check the band guide elements, such as the press rollers (a), lifting rollers (b) and locating pins, for wear.
  - If the cover band is worn, be sure also to replace the band guide elements. Worn guide elements will damage the new cover band.
  - If the cover band is damaged, only replace the band guide elements if they are damaged. Fit press rollers (a) with the larger diameter on the outer.
6. Push the new cover band with its broader side (with the chamfered cutting edge) facing downwards through the driver and fix it at one end by the clamp fitting.
7. Carefully press the cover band into its guideway along its entire length until it audibly snaps into place. It must not stick out at any point, otherwise it will be damaged.
8. Clamp the press rollers in place.
9. Stretch the cover band and fix it by the clamp fitting at the other end.
10. Bolt on the stripper brushes (if fitted).
11. To check that the carriage is correctly installed, run it slowly from one end of the linear unit to the other, ensuring the cover band is held all the time in its guideway.

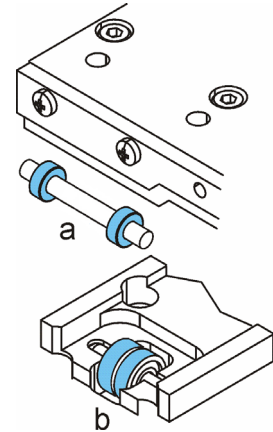

### 10.3 Your added value in service: Repair and Retrofit

In addition to installation and maintenance, we also offer professional repair and retrofit services for our products. You benefit from our expertise, fast fault diagnosis, and expert repairs – helping to extend the service life of your products and modernize existing systems.

For further information regarding repairs or retrofit solutions, please contact our customer service at [service.greifsysteme@de.schunk.com](mailto:service.greifsysteme@de.schunk.com).

We will be happy to advise you.