

Original Assembly and Maintenance Manual

Linear Unit



Types

Beta 60-ZSS
Beta 70-C-ZRS-ZSS
Beta 80-ZRS-ZSS
Beta 80-C-ZRS-ZSS
Beta 100-ZRS-ZSS
Beta 100-D-ZSS-ZSA
Beta 110-ZRS-ZSS
Beta 120-ZRS-ZSS
Beta 120-C-ZSS
Beta 140-ZRS-ZSS
Beta 140-C-ZSS
Beta 165-ZSS
Beta 180-ZSS
Beta 180-C-ZSSS

HSB Automation GmbH
In Laisen 74
72766 Reutlingen
Germany
Tel. +49 7121 14498-0
info@hsb-automation.de
www.hsb-automation.de

Distributor:
SCHUNK GmbH & Co. KG
Spann- und Greiftechnik
Bahnhofstr. 106 - 134
74348 Lauffen/Neckar
Germany
Tel. +49 7133-103-0
Fax +49 7133-103-2399
info@de.schunk.com
www.schunk.com

Contents

1	Safety	3
1.1	Symbols used	3
1.2	Regulation use	3
1.3	General safety	4
1.5	Use in explosive areas.....	4
1.6	Technical condition of the linear unit.....	4
1.7	Modifications to the linear unit	5
1.8	Requirements for personnel.....	5
1.9	Responsibilities of the operator.....	5
2	Warranty	6
3	Technical data – Standard model	7
4	Product description	13
5	Transportation and storage	16
6	Installation and adjustment	17
6.1	Installing the linear unit by mounting rails	17
6.2	Screwing the linear unit into place from below	18
6.3	Setting maximum travel	18
6.3.1	Setting the positions of the inductive limit switches	19
6.3.2	Setting the positions of the mechanical limit switches.....	20
6.4	Mounting a drive unit	21
6.4.1	Mounting a motor	22
7	Start-up	24
8	Operation	25
9	Shutdown	26
10	Maintenance	26
10.1	Lubrication.....	27
10.2	Replacing the timing belt	30
10.3	Replacing cover bands	34
10.4	Your added value in service: Repair and Retrofit.....	36

About this manual

Applicability

This manual applies to the following linear units with timing belt drive:

- Beta 60-ZSS
- Beta 70-C-ZRS-ZSS
- Beta 80-ZRS-ZSS
- Beta 80-C-ZRS-ZSS
- Beta 100-ZRS-ZSS
- Beta 100-D-ZSS
- Beta 100-D-ZSA
- Beta 110-ZRS-ZSS
- Beta 120-ZRS-ZSS
- Beta 120-C-ZSS
- Beta 140-ZRS-ZSS
- Beta 140-C-ZSS
- Beta 165-ZSS
- Beta 180-ZSS
- Beta 180-C-ZSS

The drawings show the Beta 60-ZSS type and serve as examples for all other types, though some of the details may differ.

1 Safety

The Assembly and Maintenance Manual is a component element of the product package, and must always be kept to hand as a reference source.

The Manual must be passed on if the unit is sold on or given away.

If there is anything in this manual which you do not fully understand, please be sure to contact the manufacturers.

1.1 Symbols used

This manual employs the following symbols to indicate hazards as well as other types of symbol:

DANGER



Indicates immediate danger.

Failure to observe this notice entails risk of death or very serious injury.

WARNING



Indicates a danger carrying a medium to high risk.

Failure to observe this notice may result in death or serious injury.

CAUTION



Indicates minor risk.

Failure to observe this notice may result in light to moderate injury or damage to property.

 Note

Indicates tips on use of the machine and optimising its efficiency.

1.2 Regulation use

The mechanical linear unit is intended for installation in machines, and is used solely for manipulating, positioning, transporting, palletising, loading, unloading, clamping, clacking, tensioning, testing, measuring, handling and pushing workpieces or tools.

Pay attention to the basic applications of the linear unit set out in sections 4 and 3.

In order to comply with the EU Directive governing Electromagnetic Compatibility (EMC), the mechanical linear unit may only be used in industrial environments.

Any other use, or use for purposes beyond those stipulated, will be classed as illegitimate. The manufacturers accept no liability for any loss thereby incurred. The risk is borne solely by the operators.

1.3 General safety

Preconditions for operation	The linear unit must not be put into operation until the machine or line into which it is installed conforms to the following: <ul style="list-style-type: none">• EC/EU directives• Standards governing the electromagnetic compatibility of machinery
Safe operation	To ensure safe operation, refer to the following documents: <ul style="list-style-type: none">• This operating manual for the linear unit, particularly the technical data• The operating manual for the line into which it is installed
Decommissioning	Dispose of the product in accordance with the applicable national requirements. Observe the safety data sheets.

1.4 Use in clean rooms (ISO 14644)

The linear units used in clean rooms are fitted with a vent hole (generally G1/4") at the basic profile.

The following guidelines must be observed:

- The linear unit must be subjected to a negative pressure of 0.2 bar.
- The linear unit must be relubricated with a grease suitable for use in clean rooms (basic lubrication carried out using Klübersynth BEM 32-34).

1.5 Use in explosive areas



The linear units are suitable for use in explosive atmospheres in zones according to their ATEX marking. In addition to these assembly and maintenance instructions, the document "[FM_319_Use-in-Atex-zones-MuW](#)" must also be observed.

The following applies to Beta 100-D-ZSA:

The linear unit is not suitable for use in an explosive atmosphere.

1.6 Technical condition of the linear unit

State of the art	The unit conforms to the current state of the art and applicable rules and regulations. The device complies with the EC Machinery Directive and the relevant Harmonised Standards (European standards). Furthermore, the EC Declaration of Incorporation applies.
-------------------------	---

1.7 Modifications to the linear unit

Modifications

The linear unit must not be modified, either in its basic design or in its safety components, without our written consent. Any such unauthorised modification will void our liability in respect of the unit.

The operating company may only carry out the maintenance and repair work detailed in this operating manual. Any other measures, such as to replace wearing parts and components, may be carried out only in consultation with our service engineers, by the service engineers themselves, or by us directly.

Installed safety devices must never be dismantled or disabled.

When fitting special attachments to the unit, follow the fitting instructions provided by the manufacturers!

1.8 Requirements for personnel

Work on parts carrying live electrical current may be carried out only by trained electricians. Such work includes:

- Installing safety limit switches
- Mounting a drive unit
- Checking the direction of rotation of the drive

1.9 Responsibilities of the operator

Preservation of labels The operator must ensure that any lettering, information signs or labels are fully legible (in particular the serial number) and always observed. Any damaged or illegible information signs and labels must be replaced.

Accident Prevention and Environmental Protection The applicable regulations for accident prevention and environmental protection must be observed.

Disposal Dispose of the product according to the relevant national regulations. Refer to the safety data sheets.

2 Warranty

The warranty conditions are laid down in the terms and conditions of delivery and payment issued at time of order. Warranty cover will be voided if:

- the unit is not operated in accordance with the stipulated regulation use;
- the instructions set out in this operating manual are not followed;
- the unit is modified without the consent of the manufacturers;
- screws sealed by locking varnish are unlocked.

The manufacturer's warranty in respect of maintenance and repair work applies only if original replacement parts are used.

3 Technical data – Standard model

Technical data Linear unit Beta type with timing belt drive	Sizes										
	Beta 60		Beta 70-C		Beta 80		Beta 80-C		Beta 100		Beta 100-D
	ZSS	ZRS	ZSS	ZRS	ZSS	ZRS	ZSS	ZRS	ZSS	ZSS	
Drive element	Timing belt										
Stroke per revolution [mm]	160	175	175	220	220	210	210	200	200	160	
Velocity max. [m/s]	5,00	8,00	5,00	8,00	5,00	8,00	5,00	8,00	5,00	5,00	
Acceleration max. [m/s ²]	30	30	30	40	40	40	40	40	40	60	
No-load torque [Nm]	1,10	1,20	1,20	1,50	1,50	1,80	1,80	2,50	2,50	5,00	
Maximum travel (standard) [mm]	7620	7640	6840	7600	7600	7580	7600	7420	7420	7720	
Repeat accuracy [mm]	±0,08	±0,08	±0,08	±0,08	±0,08	±0,08	±0,08	±0,08	±0,08	±0,08	
Operating temperature [°C] (continuous operation)	0...80	0...80	0...80	0...80	0...80	0...80	0...80	0...80	0...80	0...80	
Geometrical moment of inertia I _y [mm ⁴]	400064	583502	563227	1274608	1330612	1304382	1374486	1784876		917778	
Geometrical moment of inertia I _z [mm ⁴]	522090	852344	852687	1706029	1694165	1760119	1772461	3588262		2328902	
Length of standard carriage [mm]	190	190	190	210	210	210	210	280	280	210	
Length of long carriage [mm]	230	240	240	270	270	270	270	400	400	270	
Weight (without travel) [kg]	4,55	3,10	3,40	5,50	6,10	5,30	7,80	9,50	9,10	6,80	
Weight (per 100 mm travel) [kg]	0,59	0,59	0,38	0,60	0,85	0,65	0,98	1,10	1,45	0,75	
Weight of standard carriage [kg]	1,22	1,30	1,65	2,10	1,80	3,00	2,75	4,10	3,80	3,50	
Weight of long carriage [kg]	1,72	1,65	2,10	2,70	2,30	3,70	3,25	5,85	5,43	4,10	
Noise emission max. [dB A] ¹⁾	80	80	80	80	80	80	80	80	80	80	

¹⁾ The figure will vary based on assembly with other system components

Technical data - Linear unit Beta type with timing belt drive	Sizes								
	Beta 100-D	Beta 110		Beta 120		Beta 120-C	Beta 140		Beta 140-C
	ZSA	ZRS	ZSS	ZRS	ZSS	ZSS	ZRS	ZSS	ZSS
Drive element	Zahnriemen								
Stroke per revolution [mm]	160	300	300	240	240	300	220	220	220
Velocity max. [m/s]	5,00	8,00	5,00	8,00	5,00	5,00	8,00	5,00	5,00
Acceleration max. [m/s ²]	60	60	60	60	60	60	60	60	60
No-load torque [Nm]	5,40	3,50	3,50	3,00	3,00	4,50	2,50	2,50	2,50
Maximum travel (standard) [mm]	7720	7520	7520	7520	7520	7500	7540	7540	8100
Repeat accuracy [mm]	±0,08	±0,08	±0,08	±0,08	±0,08	±0,08	±0,08	±0,08	±0,08
Operating temperature [°C] (continuous operation)	0...80	0...80	0...80	0...80	0...80	0...80	0...80	0...80	0...80
Geometrical moment of inertia I _y [mm ⁴]	917778	4999522	4940967	3093457		7115871	3160259		3117373
Geometrical moment of inertia I _z [mm ⁴]	2328902	6042239	5979329	7081517		8943087	9121665		9047121
Length of standard carriage [mm]	172	320	320	320	320	320	320	320	320
Length of long carriage [mm]	-	500	500	500	500	500	500	500	500
Weight (without travel) [kg]	11,70	15,70	18,00	12,50	13,00	21,00	13,50	15,00	15,00
Weight (per 100 mm travel) [kg]	0,75	1,50	2,10	1,30	1,70	2,40	1,30	1,70	1,70
Weight of standard carriage [kg]	2,70	4,80	5,20	6,00	6,50	8,00	7,00	7,50	7,50
Weight of long carriage [kg]	-	7,50	8,20	9,40	10,20	12,00	11,00	11,70	11,70
Noise emission max. [dB A] ¹⁾	80	80	80	80	80	80	80	80	80

¹⁾ The figure will vary based on assembly with other system components

Technical data - Linear unit Beta type with timing belt drive	Sizes		
	Beta 165	Beta 180	Beta 180-C
	ZSS	ZSS	ZSS
Drive element	Zahnriemen		
Stroke per revolution [mm]	440	320	320
Velocity max. [m/s]	5,00	5,00	5,00
Acceleration max. [m/s ²]	60	60	60
No-load torque [Nm]	12,00	8,00	8,00
Maximum travel (standard) [mm]	6920	7500	7500
Repeat accuracy [mm]	±0,08	±0,08	±0,08
Operating temperature [°C] (continuous operation)	0...80	0...80	0...80
Geometrical moment of inertia I _y [mm ⁴]	21411115	9351064	
Geometrical moment of inertia I _z [mm ⁴]	25986463	24300412	
Length of standard carriage [mm]	400	380	380
Length of long carriage [mm]	600	600	600
Weight (without travel) [kg]	42,40	37,70	39,70
Weight (per 100 mm travel) [kg]	3,50	2,40	2,60
Weight of standard carriage [kg]	11,90	11,20	14,65
Weight of long carriage [kg]	17,90	15,70	15,75
Noise emission max. [dB A] ¹⁾	80	80	80

¹⁾ The figure will vary based on assembly with other system components

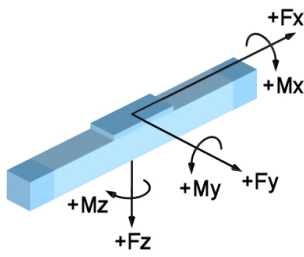

Forces and moments - Beta linear unit with timing belt drive

Type designation	Dynamic forces [N]				Dynamic moments [Nm]			
	F _X	F _Y	F _Z	-F _Z	M _X	M _Y	M _Z	M _{no-load}
Beta 60-ZSS	850	500	1400	800	50	160	100	1,10
Beta 70-C-ZRS	1100	300	1000	400	35	120	50	1,00
Beta 70-C-ZSS	1100	600	1800	1200	60	180	120	1,20
Beta 80-ZRS	1350	500	1500	800	50	180	100	1,50
Beta 80-ZSS	1350	800	3000	2000	100	250	250	1,50
Beta 80-C-ZRS	2200	1000	1500	1500	100	300	180	1,80
Beta 80-C-ZSS	2200	1600	4000	3000	300	500	500	1,80
Beta 100-ZRS	2800	1000	2500	1200	200	250	200	2,50
Beta 100-ZSS	2800	1000	3000	2000	200	250	250	2,50
Beta 100-D-ZSS	2200	1800	4000	3000	350	750	750	5,00
Beta 110-ZRS	4000	2000	5000	2500	300	600	450	3,50
Beta 110-ZSS	4000	3000	8000	4000	400	800	600	3,50
Beta 120-ZRS	4000	2500	5000	3000	350	700	700	3,50
Beta 120-ZSS	4000	3000	8000	4000	400	800	600	3,50
Beta 120-C-ZSS	4800	4000	12000	6000	600	1500	1000	3,50
Beta 140-ZRS	4000	2500	5000	3000	350	700	700	4,50
Beta 140-ZSS	4000	2500	6000	4000	500	1000	1000	4,50
Beta 140-C-ZSS	4000	3200	7500	5000	600	1200	1200	4,50
Beta 165-ZSS	10000	5000	15000	8000	700	1400	1100	12,00
Beta 180-ZSS	6000	6000	12000	6000	1500	3000	1500	8,00
Beta 180-C-ZSS	6000	8000	15000	8000	1800	3600	1800	8,00

Figures in () relate to the long carriage.

M_{no-load} = No-load torque ±30%

The forces and moments quoted are maximum values for the single load. In the event of combined loading or simultaneous occurrence of multiple moments or forces, the individual values must be reduced. In case of doubt consult Technical Support.

Dynamic load ratings of rail guides - Beta linear unit

Model	Size	Number of rails	Number of carriages	Load rating per carriage C_{dyn} [N] THK / Rex*	Pre-tension F_v [N] THK / Rex*	M_i [Nm] THK / Rex*	Guide spacing in direction x (lx1) [mm]	Guide spacing in direction y (ly) [mm]
Beta 60	15	1	2	11271 / 9860	564 / 620	60 / 74	102 (152)	
Beta 70-C	15	1	2	11271 / 9860	564 / 620	60 / 74	120 (170)	-
Beta 80	20	1	2	17700 / 23400	885 / 1500	210 / 240	131 (191)	-
Beta 80-C	25	1	2	25160 / 28600	1258 / 1820	340 / 320	122 (182)	-
Beta 100	20	1	2	17700 / 23400	885 / 1500	210 / 240	152 (272)	-
Beta 100-D-ZSS	15	2	4	11271 / 9860	564 / 620	-	150 (210)	56
Beta 100-D-ZSA	15	2	4	11271 / 9860	564 / 620	-	112	56
Beta 110	25	1	2	25160 / 28600	1258 / 1820	340 / 320	203 (383)	-
Beta 120	25	1	2	25160 / 28600	1258 / 1820	340 / 320	142 (322)	-
Beta 120-C	30	1	2	25160 / 28600	1258 / 1820	580 / 540	184 (364)	-
Beta 140	15	2	4	35558 / 36500	1778 / 2540	-	180 (360)	72
Beta 140-C-ZSS	20	2	4	11271 / 9860	564 / 620	-	200 (400)	76
Beta 165-ZSS	35	1	2	17700 / 23400	885 / 1500	985 / 890	198 (398)	-
Beta 180-ZSS	20	2	4	49448 / 51800	2472 / 3350	-	176 (396)	84

Figures in () relate to the long carriage

The load rating and pre-tension figures relate to the standard linear guidance system with recirculating linear ball bearings

* Rex = Rexroth

Static and dynamic load ratings of roller guides - Beta linear unit

Model	Size (∅) [mm]	Number of load-bearing rollers for F_z	Number of load-bearing rollers for F_y	Load rating per roller C_{stat} [N]	Load rating per roller C_{dyn} [N]	Guide spacing* in direction x [mm]		Guide spacing in direction y [mm]
						lx1	lx2	
Beta 70	20	4	2	600	1500	74 (124)	138.5 (188)	41
Beta 80	20	4	2	600	1500	95 (155)	156.5 (216)	41.5
Beta 80-C	24	4 -	- 2	1240 2300	2750 4200	- 75	148.5 -	42 -
Beta 100	28	4	2	1300	3200	136 (256)	223 (343)	47
Beta 110	28	4	2	1300	3200	175 (355)	262 (424)	66
Beta 120	35	4	2	3000	6800	148 (328)	148 (328)	70
Beta 140	35	4	2	3000	6800	202 (352)	202 (389)	98
Beta 180	35	4	2	3000	6800	272 (492)	272 (492)	121
Beta 180-C	47	4	2	6550	13500	224 (444)	224 (444)	125

The pre-tension per roller is approximately 5%

Tightening torques [Nm] for fixing screws							
Fixing screws	M4	M5	M6	M8	M10	M12	The figures given are intended as guides. For shorter insertion depths, the figures must be adjusted accordingly.
DIN912/ISO4762-8.8	2,7	5,4	9,0	22,0	43,0	74,0	
DIN912/ISO4762-10.9	3,0	5,7	9,0	22,0	43,0	74,0	
DIN912/ISO4762-12.9	3,0	5,7	9,0	22,0	43,0	74,0	

Tightening torques [Nm] for clutch with clamping hub					
Size	14	19	24	28	38
Clutch diameter [mm]	30	40	55	65	80
Screw size	M3	M6	M6	M8	M8
Tightening torque [Nm]	1,34	10,50	10,50	25,00	25,00

Tightening torques [Nm] for clutch with clamping ring hub					
Size	14	19	24	28	38
Clutch diameter [mm]	30	40	55	65	80
Screw size	M3	M4	M5	M5	M6
Tightening torque [Nm]	1,34	2,90	6,00	6,00	10,00

4 Product description

Linear unit with timing belt drive

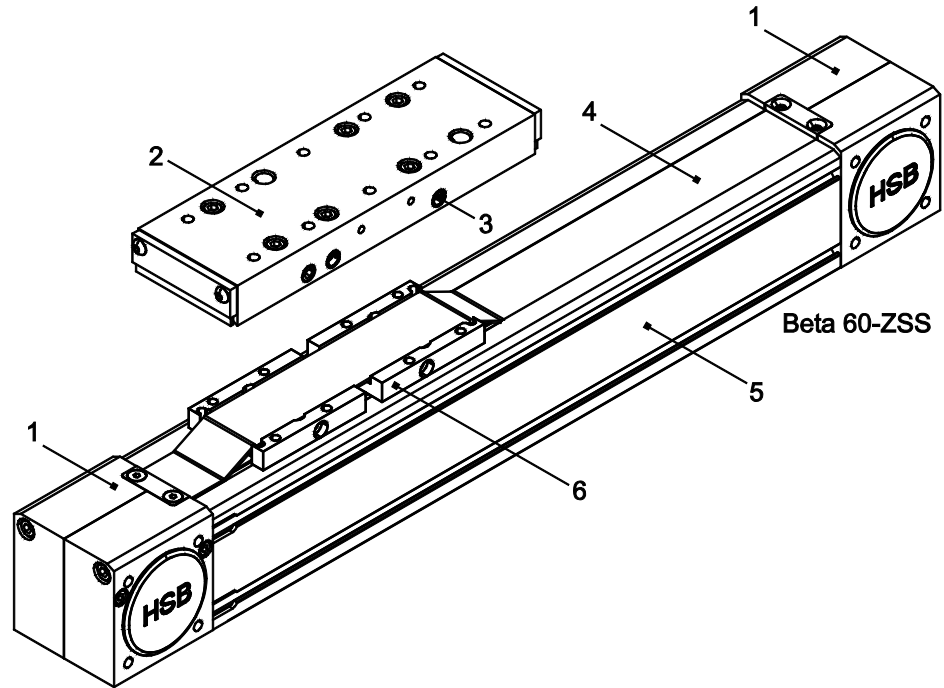

Key	1	Bearing casing	4	Cover band
	2	Carriage	5	Base profile
	3	Lubricating nipple	6	Driver

Figure 1: Component assemblies of the Beta 60 linear unit with timing belt drive

Roller bearing and linear guidance system

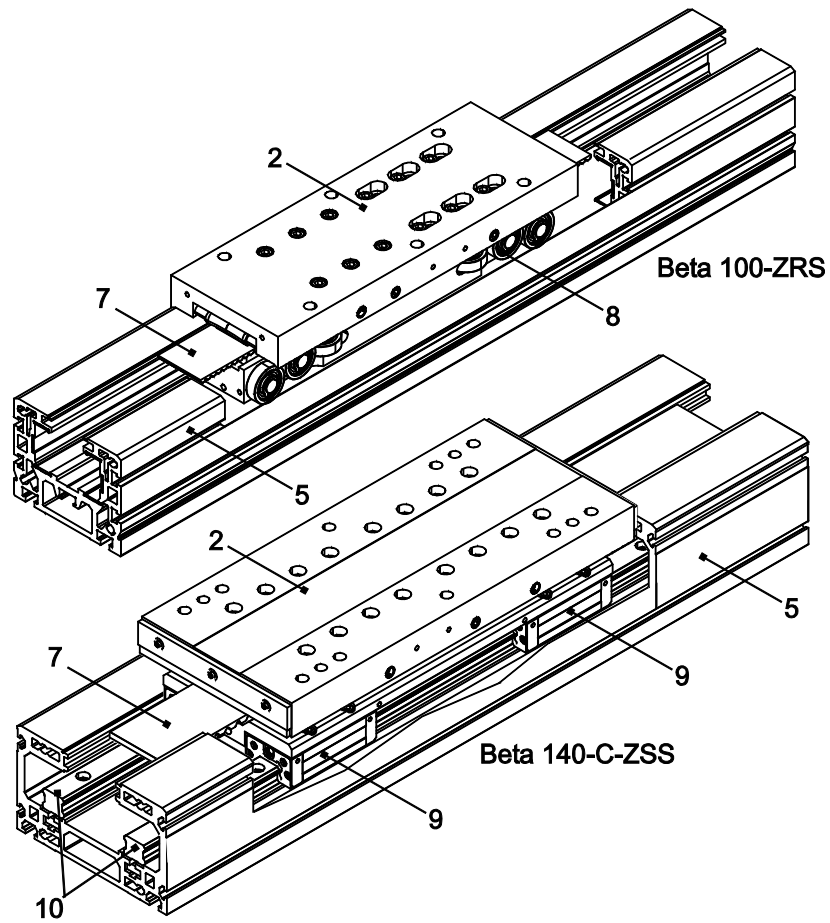

Key	2	Carriage	8	Roller bearing guidance system
	5	Base profile	9	Recirculating ball bearing
	7	Timing belt	10	Guide rails

Figure 2: Guide elements

A mechanical linear unit converts rotational motion into linear motion and is used to move loads quickly, safely and precisely from one position to another. It consists of an aluminium base profile, a moving carriage supported by a guide element (recirculating ball bearing or roller bearing guidance system) and a drive element (screw or timing belt drive).

Depending on its design, the carriage is able to absorb forces and moments in all directions, and is positively connected to the guidance and drive elements by way of the so-called drivers.

The base profile is self-supporting up to a certain length, and is equipped with grooves for mounting.

As an option, the linear unit can be equipped with accessories such as a cover, screw supports, inductive or mechanical limit switches and other fittings(see section 6.3).

The effective range can be flexibly configured. Multiple linear units of the Alpha, Beta or Delta type can be arranged two-dimensionally (2 axes) or three-dimensionally (3 axes).

Driven linear units can be connected to non-driven units of the same type by a plate, to be able to take large-area loads for example.

5 Transportation and storage

The mechanical linear unit is a precision item. Its mechanism may be damaged by heavy jolting, resulting in impairment of its functions.

CAUTION



Risk of damage by heavy jolting or bending!

Transport the assembled linear unit only with the transit protection fitted.

To prevent damage during transportation and storage, protect the linear unit against shaking and sliding as follows:

- Stow it in a box of sufficient size.
- Use packing.

Section 3 lists the unit weights.

Protect the unit against:

- dirt;
- corrosion;
- water;
- and aggressive atmospheres.

6 Installation and adjustment

The linear unit can be attached by the following methods:

- On mounting rails
- By screws inserted into the sliding blocks
- By screws inserted into the factory-fitted tapped hole rails

☛ Install the linear unit on a flat surface. Unit parallelism < 0.2 mm/1,000 mm.

☛ Mounting by the rails with tapped holes in them is the preferable solution:
for highly dynamic applications;
where the linear unit has only two attachment points.

6.1 Installing the linear unit by mounting rails

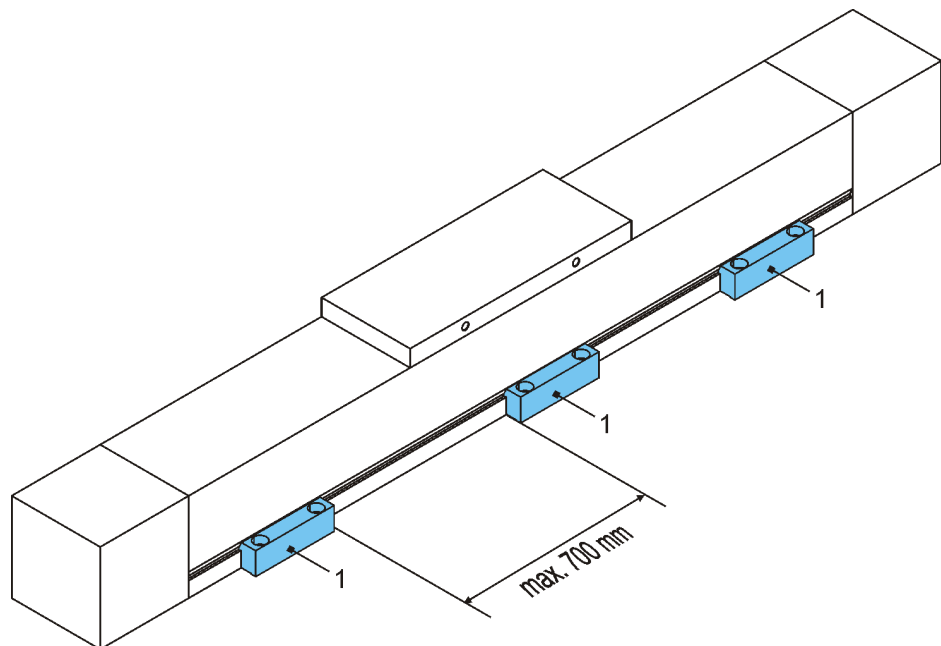

Figure 3: Mounting rails (1)

☛ The recommended maximum spacing between the mounting rails is 700 mm.

Procedure

1. Attach the mounting rails (1) loosely in position (figure 2).
2. Align the linear unit axially.
3. Tighten the mounting rails (1)
(for tightening torques see section 3).

6.2 Screwing the linear unit into place from below

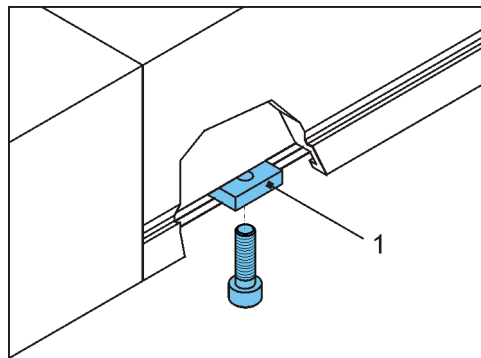

Figure 4: Sliding blocks (1) in the groove on the underside of the base profile

Attach the linear unit by the fixing screws from below using the sliding blocks or the tapped hole rails in the aluminium base profile (figure 3).

Procedure

1. Align the linear unit.
2. Align the sliding blocks (1)/tapped hole rails.
3. Tighten the linear unit
(for tightening torques see section 3).

6.3 Setting maximum travel

DANGER



Serious injury may result if the transport carriers topple over. If the carriage moves to its full extent beyond the safety zone, the transport carrier mounted on it may break away or topple over. The linear unit may be destroyed. During setup, observe the specified safety zone and set the limit switches accordingly. Electrical switches may only be connected by qualified electricians.

☛ To stop the carriage promptly in the event of an emergency stop, allow for adequate braking distance.

6.3.1 Setting the positions of the inductive limit switches

The function of inductive proximity switches is to shut down the electric drive before the mechanical end position is reached.

The necessary braking distance (ΔB) depends on the velocity and deceleration of the carriage. The braking distance must be between the switching point of the proximity switch and the actual mechanical end position.

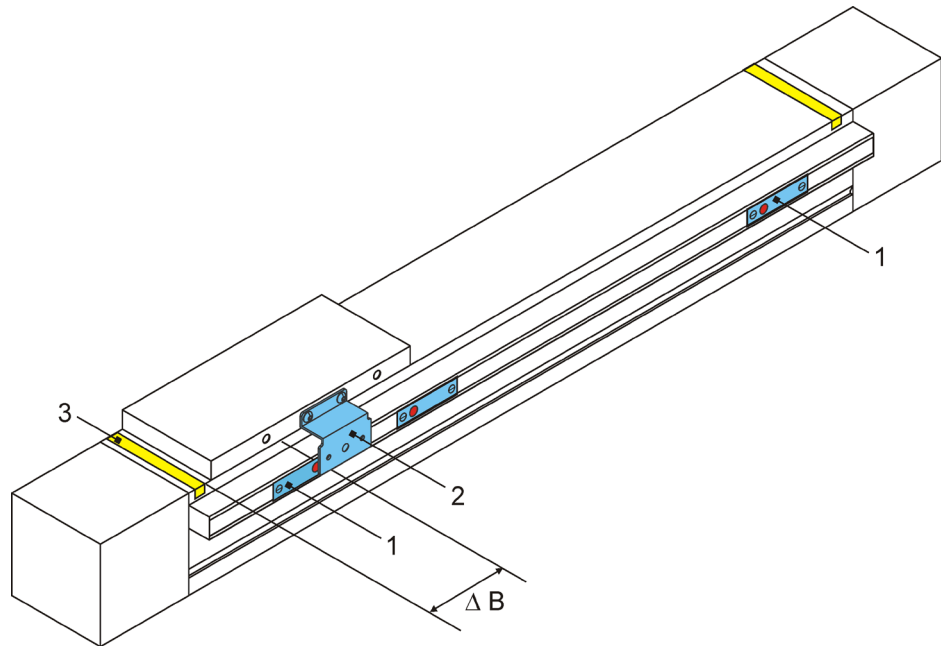

Key	1	Inductive limit switch
	2	Switching cam
	3	Band marking safety zone

Figure 5: Inductive limit switches

CAUTION



The limit switches must switch so that the carriage comes to a stop immediately before the safety zone. The safety zone is factory-marked on the unit by a band (3).

Procedure

1. Connect the power to the limit switches.
2. Slacken the limit switch fixing screws.
3. Run the carriage as far as the braking position.
4. Move the limit switch (NC contact) under the switching cam until it trips and the LED on the sensor goes out.
5. Move the carriage away.
6. Tighten the limit switch.
7. Check the correct position of the limit switch: Move the carriage manually and observe the switching operation.
8. Fit the limit switch array covering.

6.3.2 Setting the positions of the mechanical limit switches

Mechanical safety limit switches (NC contacts) must be used if a hazard is posed to personnel as soon as the electric drive fails to shut down.

The drive may only be started up when all limit switches are connected and correctly set!

A combination with inductive proximity switches is possible.

External shock-absorbers must be fitted to protect against mechanical destruction.

The necessary braking distance (ΔB) depends on the velocity and deceleration of the carriage. The braking distance must be between the switching point of the limit switch and the actual mechanical end position (figure 5).

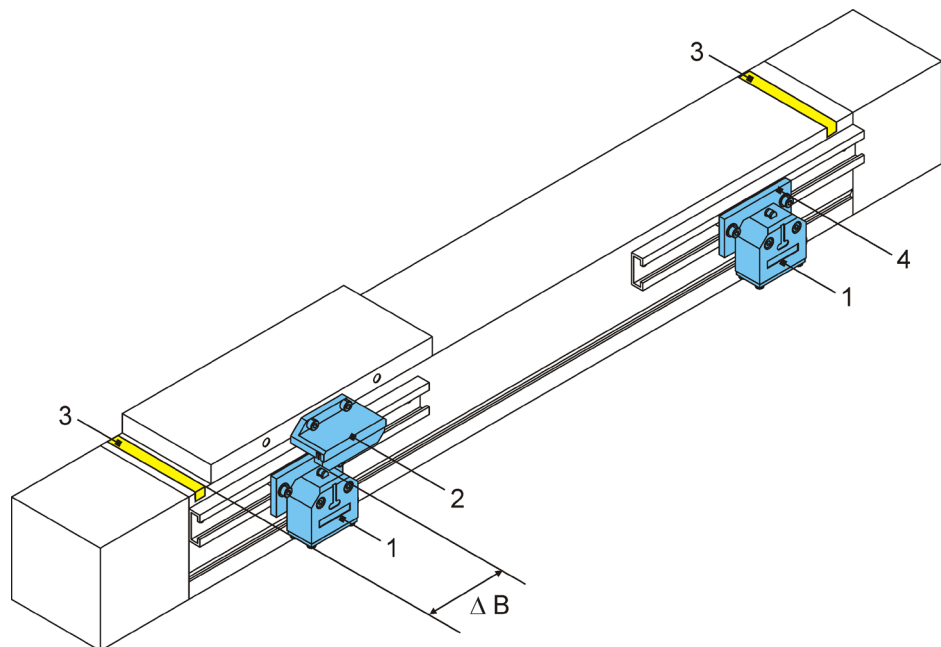

Key	1	Mechanical limit switches
	2	Switching cam
	3	Band marking safety zone
	4	Bracket
	B	Braking distance

Figure 6: Mechanical limit switches

CAUTION



The limit switches must switch so that the carriage comes to a stop immediately before the safety zone. The safety zone is factory-marked on the unit by a band (3).

Procedure

1. Connect the power to the limit switches.
2. Slacken the bracket fixing screw (figure 5).
3. Run the carriage as far as the safety zone.
4. Move the limit switch until it trips.
5. Tighten the bracket fixing screw.
6. Check the correct position of the limit switch: Move the carriage manually and observe the switching operation.
If the braking distance is too short, repeat the set-up.

6.4 Mounting a drive unit

Make sure the direction of rotation of the external drive unit takes into account the direction of the spindle or timing belt so that the limit switches work correctly.

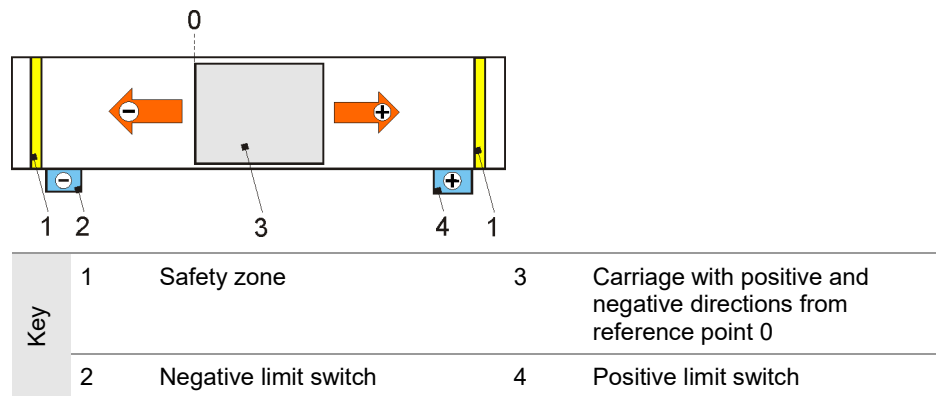
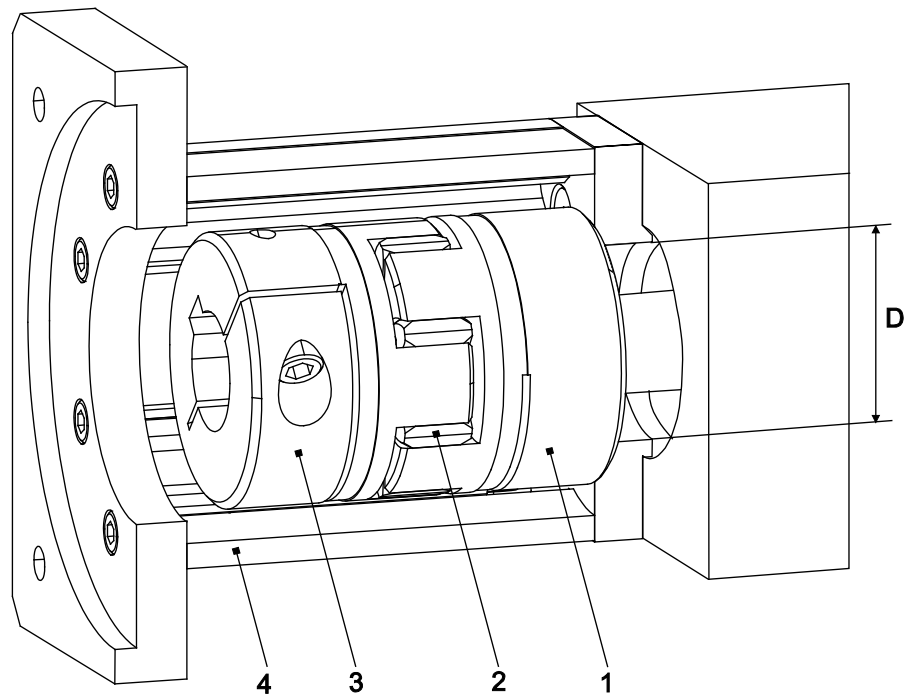

Figure 7: Example of travel direction and limit switch configuration

6.4.1 Mounting a motor



Key	1	Clutch half 1	4	Motor housing
	2	Clutch ring	D	Diameter on motor housing
	3	Clutch half 2		

Figure 8 Motor housing with motor clutch on drive pin

Procedure

1. Place the motor and the clutch components in mounting position adjacent to the linear unit.
2. Check the direction of rotation of the motor. It must take into account the safety limit switches (figure 6). Alter the direction of the motor as necessary.
3. If the clutch diameter is less than the measure D on the motor housing (4), first mount clutch half 1 (1) (hole flush with drive shaft) and then the motor housing (4) (figure 7).

If the clutch diameter is greater than the measure D on the motor housing (4), first mount the motor housing (4) and then the clutch half 1 (1) (hole flush with drive shaft). Tighten the clutch clamping screw through the mounting hole on the motor housing (4).

4. Slot the clutch ring (2) onto the clutch.
5. Mount clutch half 2 (3) on the motor pin.
6. Mount the motor on the motor housing.

Tightening torque [Nm] of clamping screws

Screw	SW	Torque
M6	5	14
M8	6	35
M10	8	65
M12	10	74

7 Start-up

WARNING



Risk of personal injury or damage to other system components caused by rapid linear motion of the transport carrier, caused by thrown loads.
Only authorised specialist personnel may start up the linear unit.

DANGER



Risk of crushing due to incorrect direction of movement of the transport devices.

Should the direction of rotation of the drive (motor or gear) and the sliding carriage drive (spindle or toothed belt) not correspond, the mounted transport devices may travel in the wrong direction. Around all rotating parts, e.g. GX shaft and around the toothed belt (when used without cover band), there is a risk of being pulled in, and of clothing or body parts being caught up and trapped. There is also a risk of crushing around the moving carriage. These hazards can be countered by installing effective safety mechanisms that comply with the current standards and are state-of-the-art. These are not supplied with the linear unit and must be installed by the manufacturer of the overall installation.

Use of the deflection belt drive without the protective hood supplied is not permitted.

Only qualified electricians may carry out the electrical installation and check the direction of rotation.

Checks before start-up

Before starting the unit, check the following:

- Make sure the retaining fixtures conform to the mass and acceleration data provided by the manufacturers.
- Make sure the machine or line into which the linear unit is installed conforms to the EU Machinery Directive, the harmonised European standards or applicable national standards.
- Make sure the linear unit is correctly installed.
- Make sure the inductive and/or mechanical limit switches are correctly connected and working properly.
- Make sure the direction of rotation of the motor shaft and - where appropriate - of the interposed gearbox - matches that of the spindle or timing belt.

If the checks reveal any defects, prohibit start-up of the unit.

Trial run

To prevent accidents, collisions and possible errors in the programming, move the linear unit along the stroke several times at such a low speed that it can be stopped in good time in case of an emergency.

The line may be started up once it has been established that there is no risk of collision when the maximum travel is overrun.

8 Operation

WARNING



The drive motor can heat up considerably during operation. In this case, refer to the operating instructions supplied for the drive motor.

CAUTION



Risk of damage from harmful environmental influences! Operate the linear unit only under the ambient conditions approved by the manufacturers.

Ambient conditions

The linear unit may only be operated within the permitted temperature range of 0 - 80 °C.

Operating the unit in damp, abrasive conditions may result in foreign objects entering components in the linear unit. To prevent this, as part of the integration of the linear unit into the entire plant, measures may need to be taken to prevent foreign bodies from penetrating, e.g. using folding plates, baffle plates, sealing air.

Duty of inspection

The proper functioning of the linear unit must be checked periodically during operation.

The responsible personnel must check the linear unit and the line for external signs of damage and defects at least once every shift.

If changes occur which are detrimental to safety, shut down the line immediately.

Emergency stop

The maximum permissible load values must not be exceeded even in an emergency stop situation.

As a rule, the category 1 emergency stop strategy (targeted braking to standstill, then de-energise) is chosen for automation equipment with moving masses. A simple emergency stop strategy is not usually effective, as the masses are still moving and can cause damage.

End position damping

The end stops and stop buffers installed in our linear modules protect the unit at low speed (commissioning). They are definitely not intended to completely protect the unit against damage at high speed and/or with a large mass.

9 Shutdown

WARNING



Risk of personal injury or damage to other system components caused by falling system components.
Only authorised specialist personnel may disassemble the linear unit.

1. Cut the power to the machine/line.
2. Dismantle the drive from the linear unit.
3. Detach the linear unit from the machine/line.

10 Maintenance

DANGER



Around all rotating parts, e.g. GX shaft and around the toothed belt (when used without cover band), there is a risk of being pulled in, and of clothing or body parts being caught up and trapped. There is also a risk of crushing around the moving carriage.

For this reason, lubrication of the linear unit may only be carried out while it is moving slowly (max. 0.025 m/s), and for any cleaning work the linear unit drive must be shut down and secured against being restarted.

- All installed ball bearings are sealed and maintenance-free.
- Remove excessive dust and dirt from the cover band and other components of the linear unit on a regular basis.
- The timing belt is maintenance-free. If the timing belt rips or is stretched beyond its elastic range, replace it.

10.1 Lubrication

Influencing factors The following factors are key to determining the exact lubrication intervals required:

- Loading
- Velocity
- Motion
- Operating temperature
- Degree of dirtying

Short lubrication intervals Short lubrication intervals are required for:

- operation under the influence of dust and dampness
- a heavy load
- high speed (up to V_{max})

Short strokes
(Short stroke design) Short stroke refers to a stroke with a value equal to or lower than that specified in the table. To achieve the best possible lubrication, relubrication should be carried out from both sides with guiding carriage short strokes and thus requires a special attachment. (Design feasibility must be checked.)

A lubrication stroke should also be carried out at least once per shift (8 hours) where possible.

Größe	12	15	20	25	25L	30	30L	35	35L
THK	40	95	120	140	175	160	210	185	250
Bosch-Rex.	40	80	100	115	160	135	180	155	210
Lubrication stroke	70	130	160	180	220	210	260	240	300

Initial lubrication

☛ Carry out an initial lubrication after starting up the unit for the first time. A basic lubrication was applied at the factory.

Refer to the lubrication regulations on the following pages.

Note Under normal operating conditions (dry environment, no dusts, etc.), the roller guide is lubricated for life with integrated lubricating felts.

Lubrication points on linear units with rail guide

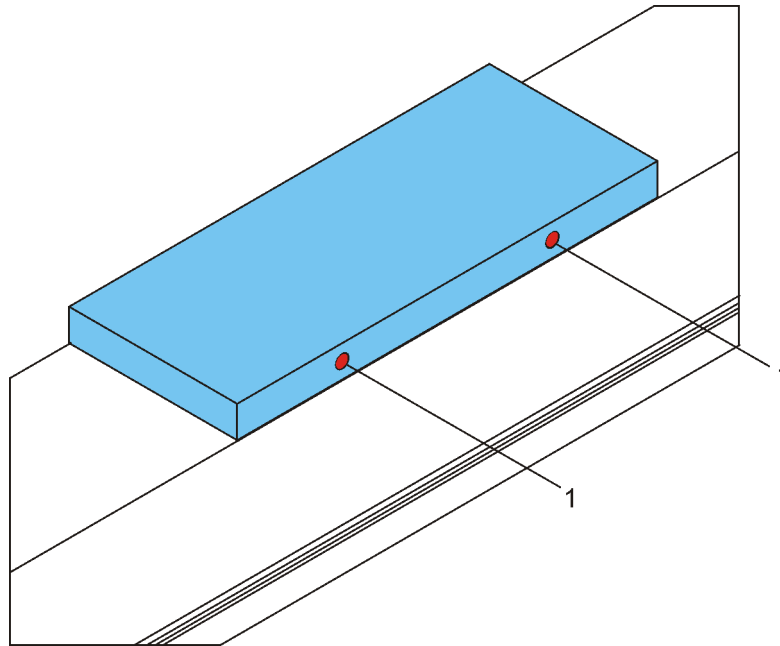

Figure 9: Possible lubrication points (1) on the carriage

The categories, quantity and positions of lubrication point depend on the model of linear unit. The categories of lubrication point are identified by the markings S, F on the unit. There is a separate lubrication schedule for each lubrication point category.

Lubrication point category	Lubrication for...	Lubricant
S	Spindle	Grease
F	Guide elements	Grease

Lubrication method

Lubrication should, as far as possible, take place while the unit is running, so that the grease is distributed evenly and no pressure is built up.

Schedule for lubrication point F (for linear guide)

Carriage size	Lubrication interval	Grease quantity [cm ³] per carriage	Grease type
15 with ball chain	approx. 5.000 km*	approx. 0.4	Grease in accordance with DIN51825-KP2N-20, e.g. Klüberplex BE 31-102 ☛ If other greases are used, pay attention to manufacturers' specifications!
20 with ball chain		approx. 0.6	
25(L) with ball chain		approx. 1.2	
30 with ball chain		approx. 1.5	
35 with ball chain		approx. 1.7	
15 without ball chain	approx. 2.000 km*	approx. 0.8	☛ Greases containing solid lubricant (e.g. graphite, MoS ₂) must not be used!
20 without ball chain		approx. 1.4	
25(L) without ball chain		approx. 2.8	
30 without ball chain		approx. 4.4	
35 without ball chain		approx. 4.4	

* Or at least 2 x per year. The lubrication interval depends on the ambient temperatures and on the loading (see figure 11). Relubrication "in motion"!

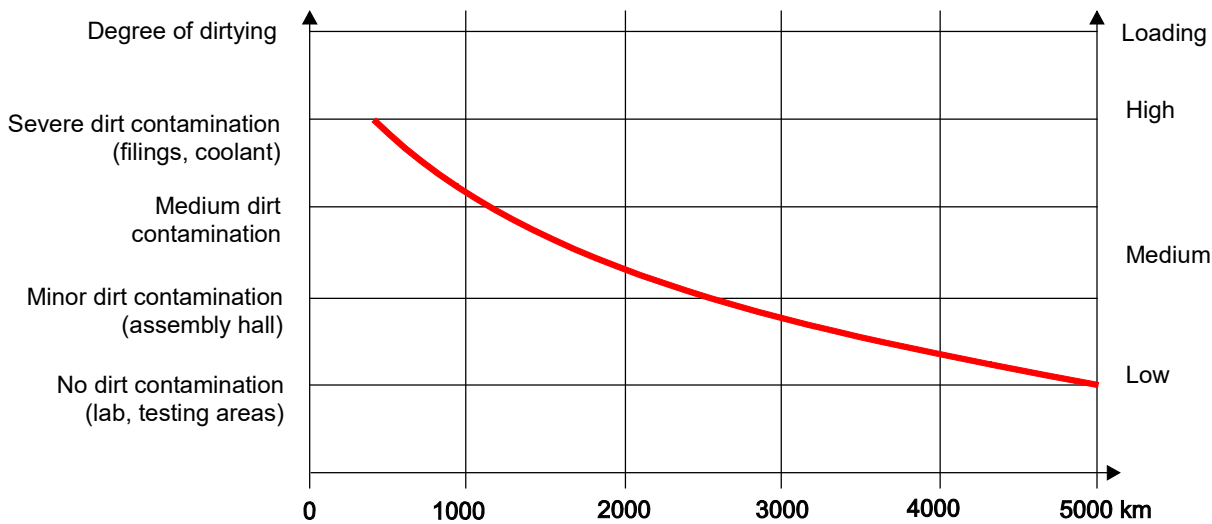

Figure 10: Relubrication intervals for the linear guidance system with recirculating linear ball bearings

10.2 Replacing the timing belt

☛ To preserve the optimum running of the linear unit and prevent it from being damaged during running operation, take care that no foreign bodies penetrate the base profile or other linear unit components during installation and assembly.

☛ Do not damage the standard parts (screws, pins, etc.) or the cover band and its elements; they will be re-used.

CAUTION



Risk of damage due to lack of lubrication!
 Do not lose or damage the O-rings fitted on the lubricating apertures, otherwise component lubrication will not be guaranteed.

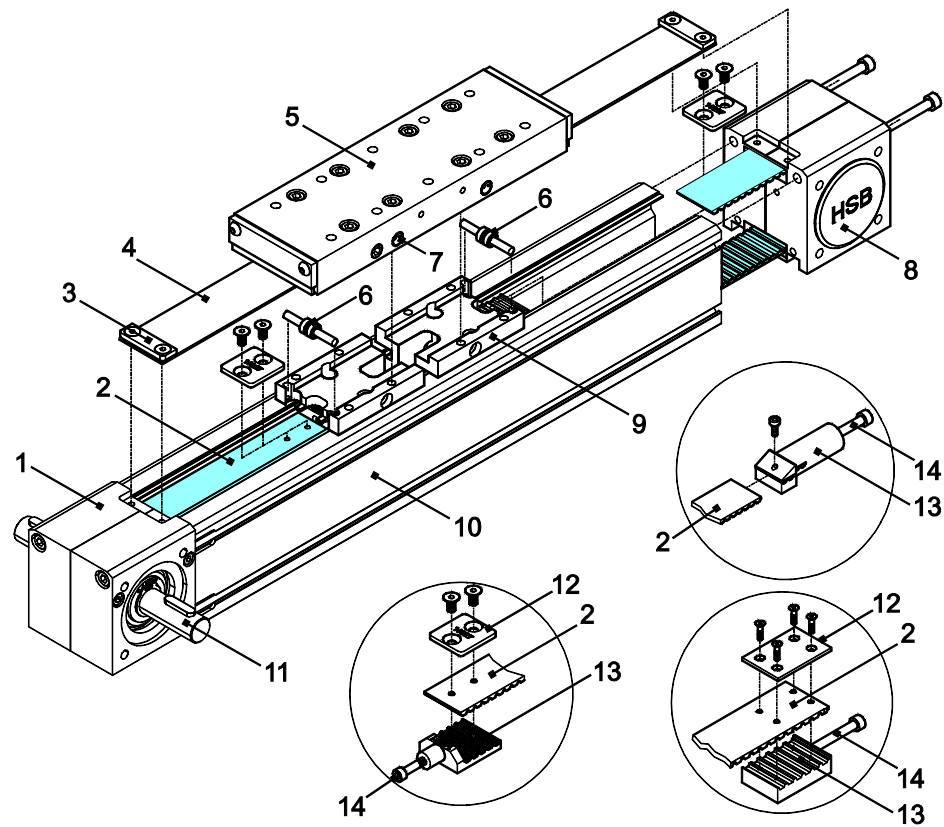

Key	1	Driven bearing casing	8	Non-driven bearing casing
	2	Timing belt	9	Driver
	3	Clamp fitting	10	Base profile
	4	Cover band	11	Drive shaft
	5	Carriage	12	Timing belt holder plate
	6	Lift roller	13	Timing belt holder
	7	Lubricating nipple	14	Clamping screws

Figure 11: Exposing and replacing the timing belt

Procedure

1. Dismantle the drive unit (motor, gearbox).
2. Loosen the lubricating nipples:
 - On Beta 60 to 80
Unscrew all screw-fit lubricating nipples (a) about 2 turns so as not to damage the sealing faces.
 - On Beta 60 to 80
Remove all conical lubricating nipples or the external lubrication ports and unscrew the lubricating adapters (a) about 2 turns so as not to damage the sealing faces.
 - On Beta 100 to 180
Remove all screw-fit or conical lubricating nipples (a) or the external lubrication ports and unscrew the lubricating adapters (b) about 2 turns so as not to damage the sealing faces.

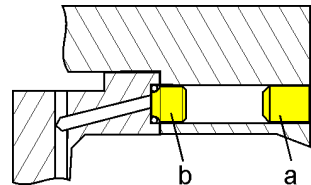
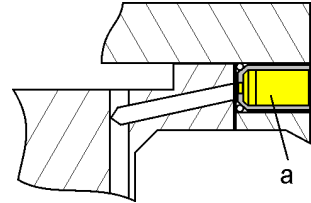
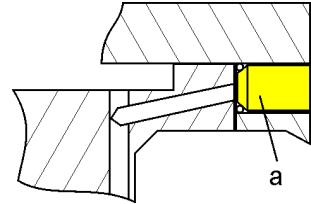

3. Run the carriage to the middle of the linear unit. Then unscrew it and lift it off.
Caution! Do not rotate the carriage. It must be refitted in the same position!
4. Unscrew the cover band clamp fittings.
5. Carefully lift the cover band over the timing belt out of its guideway and remove it.
6. Loosen the clamping screws and pull the two timing belt holders out of the driver. Do not lose the spacers, if fitted.
7. Unscrew the non-driven bearing casing.
8. With single-part timing belt holders: Unscrew the countersunk screws from the timing belt holders and detach the holders from the timing belt ends
With two-part timing belt holders: Unscrew the top parts.
9. Pull the defective timing belt out of the two bearing casings and remove it.
10. Insert the right-hand end of the new timing belt with its teeth facing upwards into the bottom slot on the non-driven bearing casing and push it out through the top slot.
11. Push the left-hand end of the new timing belt with its teeth facing upwards through the channel of the base profile.
12. Unscrew the driven bearing casing.

13. Push the left-hand end of the timing belt into the bottom slot on the driven bearing casing until the pulley engages.
14. Rotate the drive shaft by hand and push the timing belt out through the top slot in the bearing.
15. Secure the timing belt holders at the timing belt ends. Do not lock the screws with Loctite 243.
16. Attach both timing belt holders by the clamping screws (fitting spacers if available) to the driver but do not tighten them. Lock the clamping screws with Loctite 243.
17. Screw both bearings correctly onto the base profile. Lock the screws with Loctite 243.
18. Tighten the timing belt forcefully.
19. Set the precise specified tension using a tension meter (see meter operating instructions).

☛ Only by setting the correct tension as specified can optimum running be ensured.

20. The measurement position and the Hz figure applicable to the timing belt are provided along with the replacement belt. Tension the timing belt so that the specified Hz figure is indicated.
21. Insert the cover band over the timing belt with its broader side (with the chamfered cutting edge) facing downwards and fix it at one end by the clamp fitting.
22. Carefully press the cover band into its guideway along its entire length until it audibly snaps into place. Secure the loose end by the clamp fitting.

☛ The cover band must not stick out of its guideway at any point, otherwise it will be damaged.

23. Make sure the sealing rings are in the lubricating apertures on the inside of the carriage.
24. Mount the carriage in the original position on the driver(s) so that the holes of the plate precisely match the holes in the parts beneath.

Tip:

The correct alignment is indicated by the drilling template.

25. Screw the carriage to the drivers beneath. Use only the original screws. The screws must be centred in the holes.

☛ If you do not use the original screws, make sure the screws you use are not too long, otherwise they will protrude on the base profile or the cover band and cause damage.

- 26.** Replace the bands indicating the safety zones at the right and left ends of the linear unit as necessary.
- 27.** Only for linear units with cover bands above the timing belt: To ensure the cover band engages safely in its guideway, slowly move the carriage along its entire travel distance by hand.
- 28.** Fit the lubricating nipples:

- On Beta 60 to 80
Insert the screw-fit lubricating nipples.

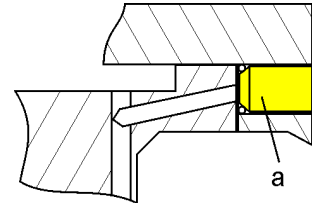

- On Beta 60 to 80
Fit the lubricating adapters and then the conical lubricating nipples or the external lubrication ports.

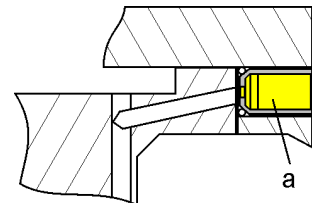

- On Beta 100 to Beta 180
Fit the lubricating adapter and then the screw-fit lubricating nipple.

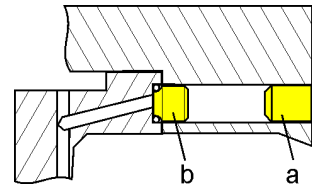

10.3 Replacing cover bands

☛ To preserve the optimum running of the linear unit and prevent it from being damaged during running operation, take care that no foreign bodies penetrate the base profile or other linear unit components during installation and assembly.

☛ Do not damage the standard parts (screws, pins, etc.) or the dismantled components; they will be refitted.

☛ If cover bands are worn, also replace the band guide elements. If cover bands are damaged, check the band guide elements for wear and replace them only as necessary.

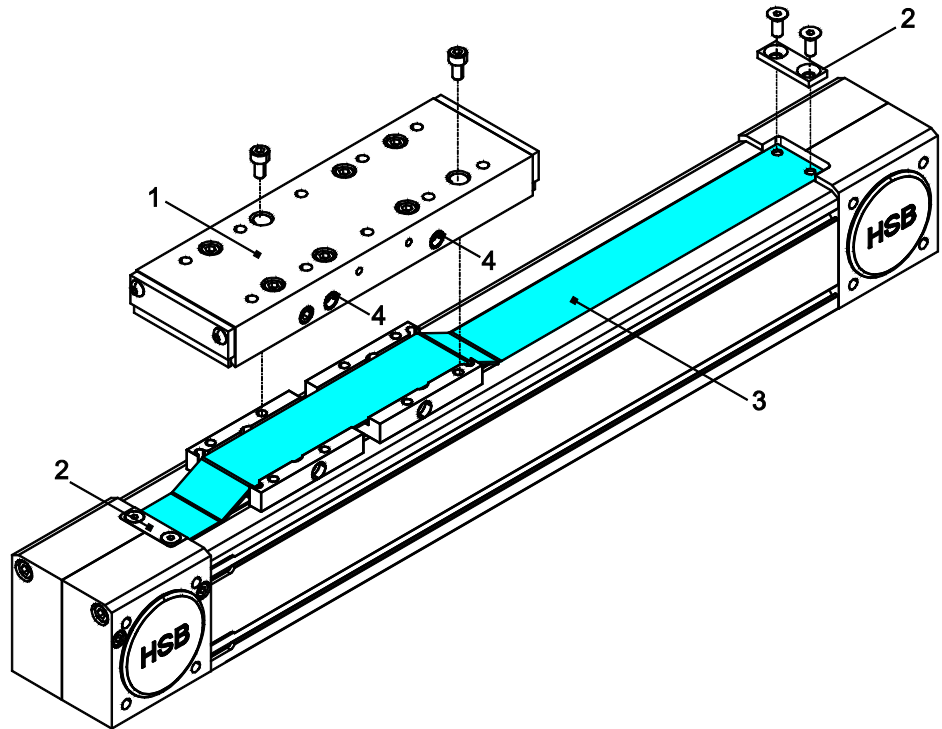

Key	1	Carriage
	2	Clamp fitting
	3	Cover band
	4	Lubricating nipple

Figure 12: Cover band based on the example of the Beta 60-ZxS linear unit

Procedure

1. Loosen the lubricating nipples:

- On Beta 60 to 80
Unscrew all screw-fit lubricating nipples (a) about 2 turns so as not to damage the sealing faces.
- On Beta 60 to 80
Remove all conical lubricating nipples or the external lubrication ports and unscrew the lubricating adapters (a) about 2 turns so as not to damage the sealing faces.
- On Beta 100 to 180
Remove all screw-fit or conical lubricating nipples (a) or the external lubrication ports and unscrew the lubricating adapters (b) about 2 turns so as not to damage the sealing faces.

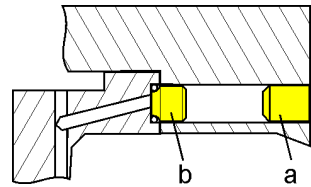
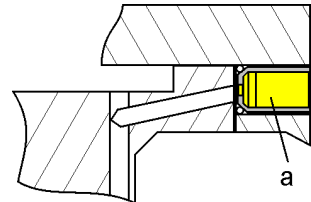
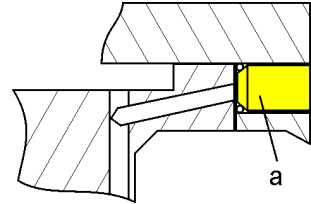

2. Move the carriage into the middle. Then unscrew it and lift it off. Caution! Do not rotate the carriage. It must be refitted in the same position!

Do not lose the O-rings fitted on the lubricating apertures on the inside of the carriage.

3. Detach the clamp fittings from the ends of the cover band and remove the cover band.

4. Check the band guide elements, such as the press rollers (a), lifting rollers (b) and locating pins, for wear.

- If the cover band is worn, be sure also to replace the band guide elements. Worn guide elements will damage the new cover band.
- If the cover band is damaged, only replace the band guide elements if they are damaged. Fit press rollers (a) with the larger diameter on the outer.

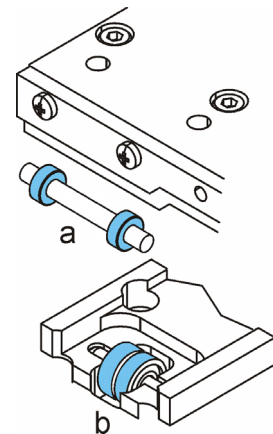

5. Insert the new cover band with its broader side (with the chamfered cutting edge) facing downwards and fix it at one end by the clamp fitting.

6. Carefully press the cover band into its guideway along its entire length until it audibly snaps into place. It must not stick out at any point, otherwise it will be damaged.

7. Stretch the cover band and fix it by the clamp fitting at the other end.
8. Make sure the O-rings are fitted on the lubricating apertures on the underside of the carriage and refit the carriage in the correct position.
9. To check that the carriage is correctly installed, run it slowly from one end of the linear unit to the other, ensuring the cover band is held all the time in its guideway.
10. Fit the lubricating nipples:

- On Beta 60 to 80
Insert the screw-fit lubricating nipples.

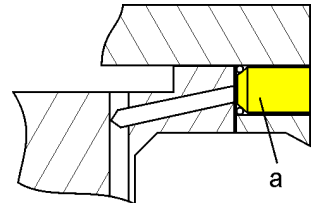

- On Beta 60 to 80
Fit the lubricating adapters and then the conical lubricating nipples or the external lubrication ports.

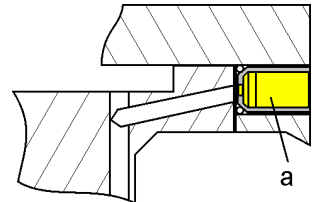

- On Beta 100 to Beta 180
Fit the lubricating adapter and then the screw-fit lubricating nipple.

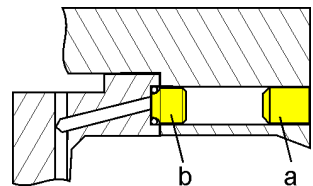

10.4 Your added value in service: Repair and Retrofit

In addition to installation and maintenance, we also offer professional repair and retrofit services for our products. You benefit from our expertise, fast fault diagnosis, and expert repairs – helping to extend the service life of your products and modernize existing systems.

For further information regarding repairs or retrofit solutions, please contact our customer service at service.greifsysteme@de.schunk.com.

We will be happy to advise you.