

Assembly and Operating Manual

ECG

Controller for electro-permanent magnetic gripper EGM

Translation of Original Operating Manual

Imprint

Copyright:

This manual is protected by copyright. The author is SCHUNK SE & Co. KG.
All rights reserved.

Technical changes:

We reserve the right to make alterations for the purpose of technical improvement.

Document number: 389769

Version: 06.00 | 10/11/2025 | en

Dear Customer,

Thank you for trusting our products and our family-owned company, the leading technology supplier of robots and production machines.

Our team is always available to answer any questions on this product and other solutions. Ask us questions and challenge us. We will find a solution!

Best regards,

Your SCHUNK team

Customer Management

Tel. +49-7133-103-2503

Fax +49-7133-103-2189

cmg@de.schunk.com



Please read the operating manual in full and keep it close to the product.

Table of Contents

1	General	5
1.1	About this manual.....	5
1.1.1	Presentation of Warning Labels	5
1.1.2	Definition of Terms	5
1.1.3	Applicable documents	6
1.1.4	Sizes.....	6
1.1.5	Variants	6
1.2	Warranty	6
1.3	Scope of delivery.....	6
2	Basic safety notes	7
2.1	Appropriate use	7
2.2	Not intended use	7
2.3	Constructional changes.....	7
2.4	Spare parts	7
2.5	Ambient conditions and operating conditions	7
2.6	Personnel qualification	8
2.7	Personal protective equipment	9
2.8	Notes on safe operation.....	9
2.9	Transport.....	10
2.10	Malfunctions.....	10
2.11	Disposal	10
2.12	Fundamental dangers	11
2.12.1	Protection against electric shock.....	11
2.12.2	Protection against magnetic and electromagnetic fields	12
3	Technical data	13
3.1	Name plate	13
3.2	Basic data	14
4	Design and description	15
4.1	Overview	15
4.2	ECG-C design.....	16
4.3	ECG-R design.....	17
4.4	ECG-W design	18
4.5	Description	18
5	Assembly and settings	20
5.1	Installing and connecting	20
5.2	Electrical connection.....	21
5.2.1	Safety device upstream of the ECG.....	21

5.2.2	ECG-C terminal configuration	22
5.2.3	ECG-R terminal configuration	24
5.2.4	ECG-W terminal configuration	27
5.2.5	ECG-C wiring diagram	30
5.2.6	ECG-R wiring diagram	31
5.2.7	ECG-W wiring diagram	32
5.2.8	Manual operating unit (optional).....	33
6	Commissioning	35
6.1	Adjusting the holding force	36
6.2	Chronological sequence of the control and status signals	36
7	Troubleshooting.....	37
7.1	Product remains inoperable even after the power supply is turned on.....	37
7.2	Workpiece disengages from the magnetic gripper.....	37
7.3	Demagnetization was not performed correctly.....	37
8	Maintenance	38
8.1	Maintenance intervals.....	38
8.2	Check and repair the product.....	38
9	EU Declaration of Conformity	39
10	UKCA declaration of Conformity	40

1 General

1.1 About this manual

This manual contains important information for a safe and appropriate use of the product.

This manual is an integral part of the product and must be kept accessible for the personnel at all times.

Before starting work, the personnel must have read and understood this operating manual. Prerequisite for safe working is the observance of all safety instructions in this manual.

In addition to these instructions, the documents listed under ▶ 1.1.3 [6] are applicable.

NOTE: The illustrations in this manual are intended to provide a basic understanding and may deviate from the actual version.

1.1.1 Presentation of Warning Labels

To make risks clear, the following signal words and symbols are used for safety notes.



⚠ DANGER

Dangers for persons!

Non-observance will inevitably cause irreversible injury or death.



⚠ WARNING

Dangers for persons!

Non-observance can lead to irreversible injury and even death.



⚠ CAUTION

Dangers for persons!

Non-observance can cause minor injuries.

NOTICE

Material damage!

Information about avoiding material damage.

1.1.2 Definition of Terms

The term "product" replaces the product name on the title page in this manual.

1.1.3 Applicable documents

- General terms of business *
- Catalog data sheet of the purchased product *
- Assembly and Operating Manual for electro-permanent magnetic gripper EGM *

The documents labeled with an asterisk (*) can be downloaded from [schunk.com/downloads](https://www.schunk.com/downloads).

1.1.4 Sizes

This operating manual applies to the following sizes:

- ECG 01
- ECG 02

1.1.5 Variants

This operating manual applies to the following variations:

- ECG-C: Holding force constant
- ECG-R: Holding force selectable (8 holding force levels)
- ECG-W: Holding force constant, optimized for welding applications

1.2 Warranty

If the product is used as intended, the warranty is valid for 24 months from the ex-works delivery date under the following conditions:

- Observance of the applicable documents
- Observance of the ambient conditions and operating conditions

Parts touching the workpiece and wear parts are not included in the warranty.

1.3 Scope of delivery

The scope of delivery includes

- ECG in the version ordered
- Assembly and Operating Manual

2 Basic safety notes

2.1 Appropriate use

The product was developed exclusively for controlling and regulating the electro-permanent magnetic gripper EGM.

- The product is designed to be built into a control cabinet. The applicable guidelines must be observed and complied with.
- The product may only be used within the scope of its technical data, ▶ 3 [13].
- The product is designed for industrial, automated use.
- Appropriate use of the product includes compliance with all instructions in this manual.

2.2 Not intended use

- Any utilization that exceeds or differs from the appropriate use is regarded as misuse.

2.3 Constructional changes

Implementation of structural changes

Modifications, changes or reworking, e.g. additional threads, holes, or safety devices, can damage the product or impair its functionality or safety.

- Structural changes should only be made with the written approval of SCHUNK.

2.4 Spare parts

Use of unauthorized spare parts

Using unauthorized spare parts can endanger personnel and damage the product or cause it to malfunction.

- Use only original spare parts or spares authorized by SCHUNK.

2.5 Ambient conditions and operating conditions

Required ambient conditions and operating conditions

Incorrect ambient and operating conditions can make the product unsafe, leading to the risk of serious injuries, considerable material damage and/or a significant reduction to the product's life span.

- Make sure that the product is used only in the context of its defined application parameters, ▶ 3 [13].
- Make sure that the product is a sufficient size for the application.

- Make sure that the environment is free from splash water and vapors as well as from abrasion or processing dust. Exceptions are products that are designed especially for contaminated environments.

2.6 Personnel qualification

Inadequate qualifications of the personnel

If the personnel working with the product is not sufficiently qualified, the result may be serious injuries and significant property damage.

- All work may only be performed by qualified personnel.
- Before working with the product, the personnel must have read and understood the complete assembly and operating manual.
- Observe the national safety regulations and rules and general safety instructions.

The following personal qualifications are necessary for the various activities related to the product:

Trained electrician

Due to their technical training, knowledge and experience, trained electricians are able to work on electrical systems, recognize and avoid possible dangers and know the relevant standards and regulations.

Qualified personnel

Due to its technical training, knowledge and experience, qualified personnel is able to perform the delegated tasks, recognize and avoid possible dangers and knows the relevant standards and regulations.

Instructed person

Instructed persons were instructed by the operator about the delegated tasks and possible dangers due to improper behaviour.

Service personnel of the manufacturer

Due to its technical training, knowledge and experience, service personnel of the manufacturer is able to perform the delegated tasks and to recognize and avoid possible dangers.

2.7 Personal protective equipment

Use of personal protective equipment

Personal protective equipment serves to protect staff against danger which may interfere with their health or safety at work.

- When working on and with the product, observe the occupational health and safety regulations and wear the required personal protective equipment.
- Observe the valid safety and accident prevention regulations.
- Wear protective gloves to guard against sharp edges and corners or rough surfaces.
- Wear heat-resistant protective gloves when handling hot surfaces.
- Wear protective gloves and safety goggles when handling hazardous substances.
- Wear close-fitting protective clothing and also wear long hair in a hairnet when dealing with moving components.

2.8 Notes on safe operation

Incorrect handling of the personnel

Incorrect handling and assembly may impair the product's safety and cause serious injuries and considerable material damage.

- Avoid any manner of working that may interfere with the function and operational safety of the product.
- Use the product as intended.
- Observe the safety notes and assembly instructions.
- Do not expose the product to any corrosive media. This does not apply to products that are designed for special environments.
- Eliminate any malfunction immediately.
- Observe the care and maintenance instructions.
- Observe the current safety, accident prevention and environmental protection regulations regarding the product's application field.

2.9 Transport

Handling during transport

Incorrect handling during transport may impair the product's safety and cause serious injuries and considerable material damage.

- When handling heavy weights, use lifting equipment to lift the product and transport it by appropriate means.
- Secure the product against falling during transportation and handling.
- Stand clear of suspended loads.

2.10 Malfunctions

Behavior in case of malfunctions

- Immediately remove the product from operation and report the malfunction to the responsible departments/persons.
- Order appropriately trained personnel to rectify the malfunction.
- Do not recommission the product until the malfunction has been rectified.
- Test the product after a malfunction to establish whether it still functions properly and no increased risks have arisen.

2.11 Disposal

Handling of disposal

The incorrect handling of disposal may impair the product's safety and cause serious injuries as well as considerable material and environmental harm.

- Follow local regulations on dispatching product components for recycling or proper disposal.

2.12 Fundamental dangers

2.12.1 Protection against electric shock

Work on electric equipment

Touching live parts can result in death.

- Work on electrical installations must be performed only by electricians in accordance with the electrical regulations.
- Observe the general installation and safety regulations concerning work on high-voltage systems.
- Lay electrical cables properly, e.g. in a cable duct or cable bridge. Observe standards.
- Before connecting or disconnecting electric cables: switch off the voltage supply and check that lines are dead.
- Before switching on the product, check whether the protective conductor on all electrical components has been installed correctly according to the connection diagram.
- Check whether covers and safety equipment to prevent contact with live components have been installed.
- Do not touch the connecting elements of the product when the voltage supply is switched on.

Possible electrostatic energy

Components or assembly groups may become electrostatically charged. When the electrostatic charge is touched, the discharge may trigger a shock reaction leading to injuries.

- The operator must ensure that all components and assembly groups are included in the local potential equalisation in accordance with the applicable regulations.
- While paying attention to the actual conditions of the working environment, the potential equalisation must be implemented by a specialist electrician according to the applicable regulations.
- The effectiveness of the potential equalisation must be verified by executing regular safety measurements.

2.12.2 Protection against magnetic and electromagnetic fields

Work in areas with magnetic and electromagnetic fields

Magnetic and electromagnetic fields can lead to serious injuries.

- Persons with pace-makers, metal implants, metal shards, or hearing aids require the consent of a physician before entering areas in which components of the electric drive and control systems are mounted, started up, and operated.
- Persons with pace-makers, metal implants, metal shards, or hearing aids require the consent of a physician before entering areas in which magnetic grippers or motor parts with permanent magnets are stored, repaired, or assembled.
- Do not operate high-frequency or radio devices in the proximity of electric components of the drive system and their feed lines.



If the use of such devices is necessary:

When starting up the electric drive and control system, check the machine or automated system for possible failures when such systems are used at different intervals and in different states of the control system. A special additional EMC test may be necessary if the system has a high risk potential.

3 Technical data

3.1 Name plate

The name plate is located on the side of the controller cover:

Id. No.		Type		 <p>SCHUNK GmbH & Co. KG Spann- und Greiftechnik Bahnhofstr. 106 – 134 D-74348 Lauffen/Neckar Tel. +49-7133-103-0 Fax +49-7133-103-2399 info@de.schunk.com schunk.com</p> 
Serial No.		Work No.		
Voltage		Frequency		
Channels		Phases		
Current		Icc		
Year		Weight		
Main Document				

Name plate

Information	Description
Id. No.	SCHUNK ID no.
Type	Model
Serial no.	Serial no. of the ECG
Work no.	Order no. of the production
Voltage	Rated voltage (mains)
Frequency	Rated frequency (mains)
Channels	Number of output channels
Phases	Phases (mains)
Current	Rated current (mains)
Icc	Rated short circuit current
Year	Year of manufacture
Weight	Weight

Do not remove the name plate. When consulting with SCHUNK, always specify serial and ID numbers.

3.2 Basic data

Designation	ECG					
	-C	-R	-W	-C	-R	-W
		01			02	
ECG with a constant holding force	X			X		
ECG with a preselectable holding force		X *			X	
ECG with a constant holding force for welding applications (fusion welding processes)			X			X
Mechanical operating data						
Dimensions LxWxH [mm]	-C01 / -C02 215 x 110 x 100	-R01 / -R02 288 x 110 x 100	-W01 / -W02 650 x 110 x 100			
Weight [kg]	1	1	2			
IP protection class	20					
Ambient temperature [°C]						
Min.	+5					
Max.	+55					
Air humidity [%]						
Min.	5					
Max.	50					
Electrical operating data						
Power supply [V AC]	400					
Maximum current [A] **	32					
Rated frequency [Hz]	50					
Optional versions ***						
Power supply [V AC]	200 – 230 – 460					
Rated frequency [Hz]	60					

* Possible combinations ECG-R 01/Clarify EGM with SCHUNK.

** Depending on combination ECG/EGM

*** If necessary contact SCHUNK.

More technical data is included in the catalog data sheet.

Whichever is the latest version.

4 Design and description

4.1 Overview

The following illustration provides a general overview. An ECG-R controller is shown. The important points are marked for correct cabling.

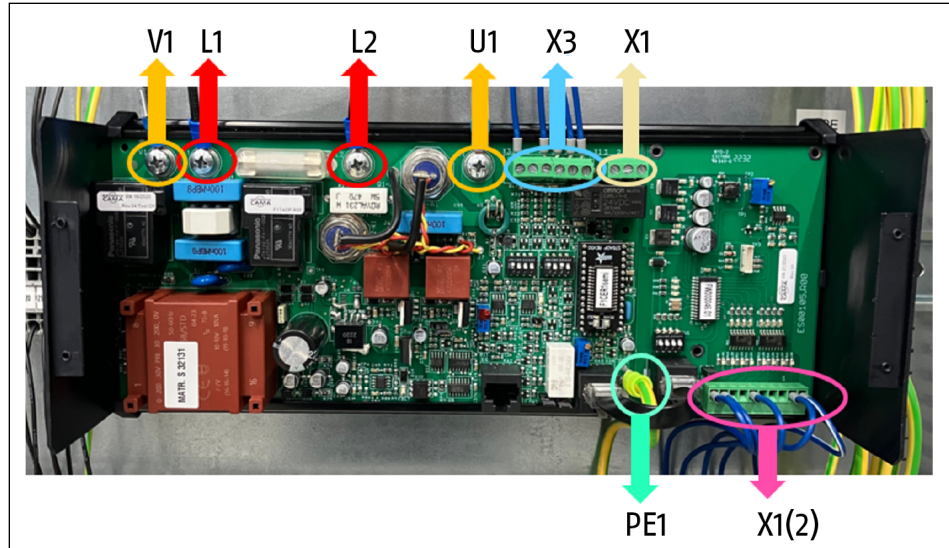

Interfaces, as illustrated by the ECG-R

Interface	Description
L1	Supply voltage
L2	
U1	Output power – magnetic system
V1	
X1 (2)	Holding force level pre-selection
X3	EGM actuation signal inputs
PE1	Ground connection
X1	Status display signal outputs

Cabling instructions

- To supply the controller with power, connect two of the 400 V power supply cables to the marked pins L1 and L2.
- To connect the magnetic unit to the power supply, use pins V1 and U1.

The earth connection is also important: connect the PE cable to pin PE1.

- Connect terminal strips X1(2) and X3 to the PLC or the robot controller. A detailed description of all the individual pins of the terminal strips can be found in the following sections!
- It is possible to connect the X1 strip to the PLC in order to receive feedback on the magnet status on the PLC.

Additional note: Connect all ground cables to one potential!

4.2 ECG-C design

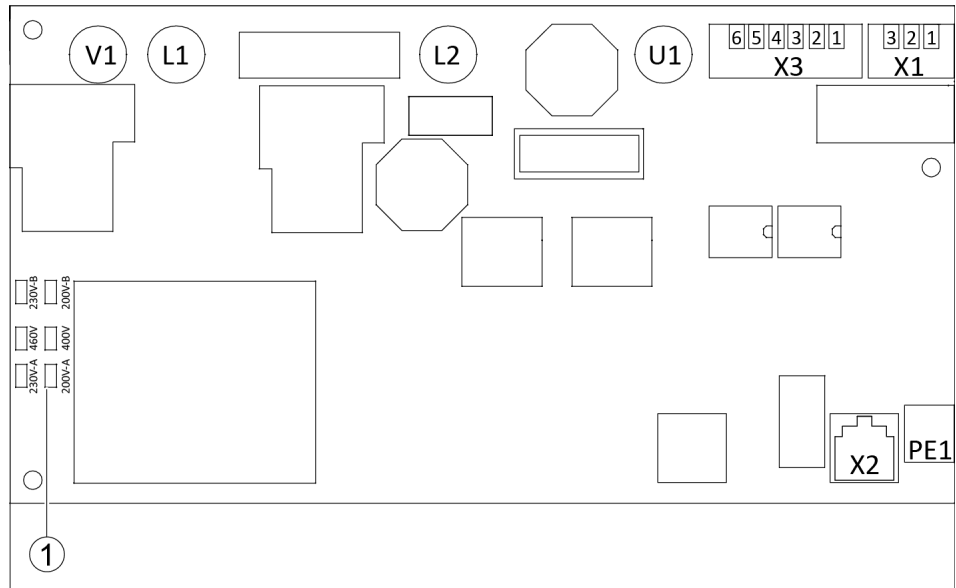

ECG-C interfaces

Interface	Description
(1)	Operating voltage NOTICE! The operating voltage is preset and may only be changed by SCHUNK.
L1	Power area – supply voltage
L2	
U1	Power area – magnetic system
V1	
PE1	Ground connection
X1	Signal outputs status display (terminals 1–3)
X2	Manual operating unit (optional)
X3	Signal inputs actuation EGM (terminals 1–6)

4.3 ECG-R design

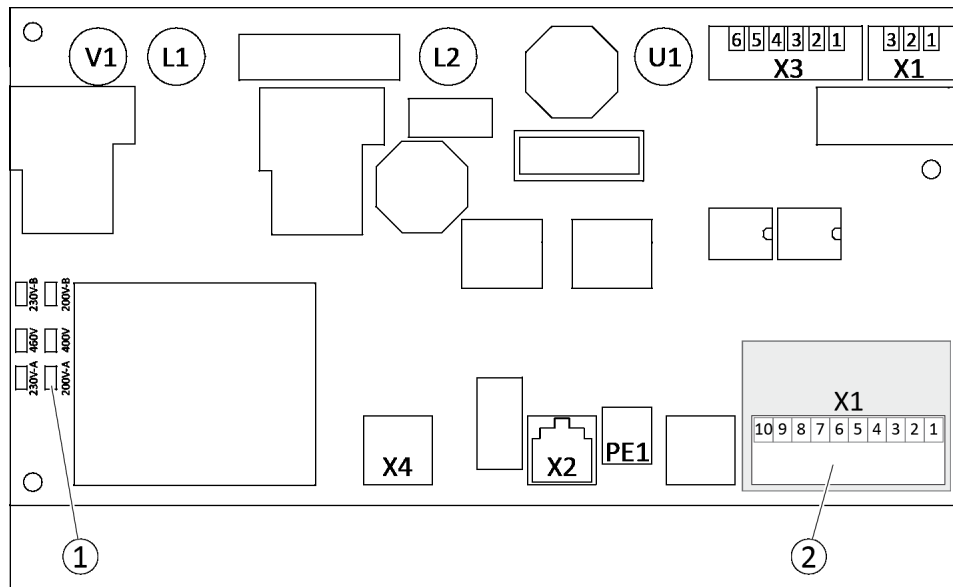

Interfaces ECG-R with additional terminal X1 (item 2)

Interface	Description
(1)	Operating voltage NOTICE! The operating voltage is preset and may only be changed by SCHUNK.
L1	Power area – supply voltage
L2	
U1	Power area – magnetic system
V1	
PE1	Ground connection
X1	Signal outputs status display (terminals 1–3)
X2	Manual operating unit (optional)
X3	Signal inputs actuation EGM (terminals 1–6)
X1 (2)	Preselection holding force level (terminals 1–10)
X4	Internal use NOTICE! For SCHUNK service employees only.

4.4 ECG-W design

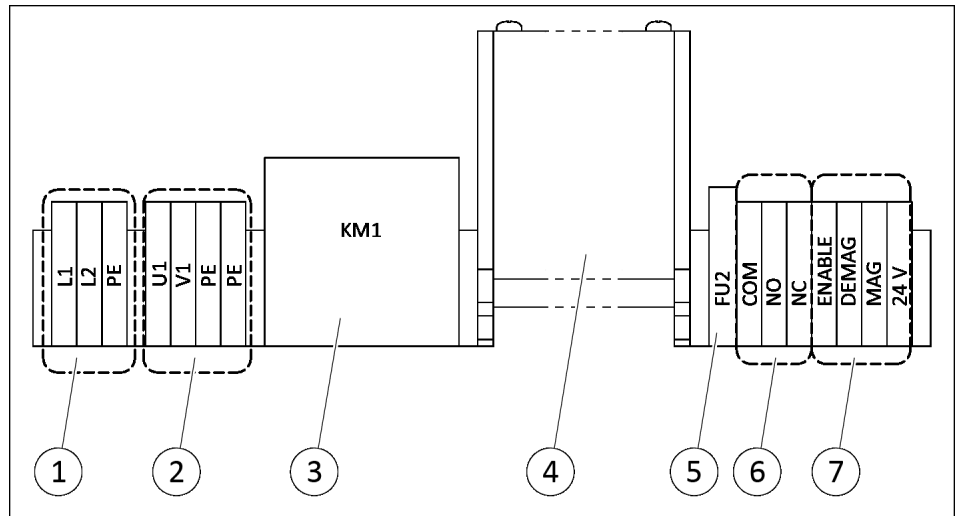

ECG-W interfaces

Interface	Description
1	Power area – supply voltage
2	Power area – magnetic system
3	Power area – relay
4	Control unit
5	Actuation area – fuse protection
6	Actuation area – signal outputs status display
7	Actuation area – signal inputs actuation EGM

4.5 Description

The product serves as an interface for higher-level controlling for the actuation of electro-permanent magnetic grippers of type EGM. Depending on the size, the product can actuate up to 32 magnetic grippers. A simple connection of several magnets is possible using a junction box. This can be positioned freely in the field.

The sizes of the product are designed for work with the following magnetic grippers:

- ECG 01: Small monopolar EGM
- ECG 02: Bipolar EGM and large monopolar EGM

The variants of the product differ in the following characteristics:

- ECG-C:
The product works with constant power. The connected magnetic gripper is always activated with the maximum achievable holding force.

- ECG-R:
The product works with selectable power levels. Before activating the connected magnetic gripper, one of 8 available holding force levels is set. In the "Magnetized" state the holding force level can be increased. A low holding force can only be configured after demagnetization.
- ECG-W:
The product works with constant power and is equipped with a relay that ensures all poles of the connected magnetic gripper are disconnected after every activation. This enables the deployment of the magnetic gripper in combination with welding operations on the held workpiece. The connected magnetic gripper is always activated with the maximum achievable holding force.

5 Assembly and settings

5.1 Installing and connecting

NOTICE

Material damage due to improper assembly!

Splash water, vapors, contamination, overheating and EMC impact may cause damage to the product.

- Install the product in a control cabinet (protection class IP54 or higher).
- Mount the product horizontally.
- Protect the product from foreign objects.
- Observe assembly distances.
- Keep ventilation slits unobstructed.

■ Safety device is installed.

1. Check the effectiveness of the safety device installed upstream of the product.
2. Mount the product in the control cabinet.
3. Open the product cover by removing the fastening screws on the cover.
4. Connect all electrical cables, ▶ 5.2 [📄 21]:
 - ⇒ Terminal PE1: Connect ground.
 - ⇒ Terminals L1 and L2: Connect voltage supply.
 - ⇒ Terminals U1 and V1: Connect magnetic gripper.
 - ⇒ Terminal X3: Connect actuation.
 - ⇒ Terminal X1: Connect the magnetic system feedback.
 - ⇒ **Only ECG-R:**
Terminal X1 on supplementary printed circuit board: Connect holding force level actuation.
 - ⇒ **Only ECG-W:**
All the wiring is carried out via the connection terminals on the side of the product housing.
5. Close the product cover and secure it with the fastening screws.

5.2 Electrical connection



⚠ DANGER

Danger from electric voltage!

Touching live parts may result in death.

- Switch off the power supply before any assembly, adjustment or maintenance work and secure against being switched on again.
- Only qualified electricians may perform electrical installations.
- Check if de-energized, ground it and hot-wire.
- Cover live parts.

NOTICE

Damage due to faulty connection!

A faulty connection can cause damage to the product.

- Observe the pin allocation of the connecting terminals.
- Make sure that all components are grounded correctly.

For the connection of a magnetic gripper, a separately available power cable is required, see catalog data sheet EGM.

NOTE

The following wiring diagrams are **only** valid for the single channel connection to the controller ECG-C/R/W.

Observe the wiring diagram included for customer-specific ECGs.

5.2.1 Safety device upstream of the ECG

A safety device with the following safety functions must be installed upstream of the product:

Circuit breaker designed for nominal current of 32 A. Depending on the design, the following tripping characteristics are permitted:

- Fuse with tripping characteristic aM
OR
- Circuit breaker with tripping characteristic C

Fault circuit interrupter:

Highly-sensitive version for fault currents from 30 mA and with tripping characteristic A or B

Protective grounding:

The PE conductor of the power cable must always be connected with an earthing connection.

WARNING! The effectiveness of the safety device must be checked regularly by an electrician.

5.2.2 ECG-C terminal configuration

5.2.2.1 Jumper operating voltage

NOTE

The operating voltage is preset and may only be changed by SCHUNK.

If the operating voltage is changed retroactively, contact SCHUNK.

5.2.2.2 Terminals in power area (L1, L2, U1, V1)

The voltage supply and the magnetic gripper power is connected to the following terminals:

Terminal	Description
L1	Input voltage phase 1
L2	Input voltage phase 2
U1	Supply voltage magnetic gripper
V1	Supply voltage magnetic gripper

- Connect terminals L1 and L2 to one of the 400 V AC cables from the supply cable.
- Connect terminals U1 and V1 to the magnetic unit using one of the cables from the connection cable.
- Connect the PE cable. A neutral conductor is not required.

5.2.2.3 Control terminal (X3)

The signal lines are connected to the "Control" terminal (X3).

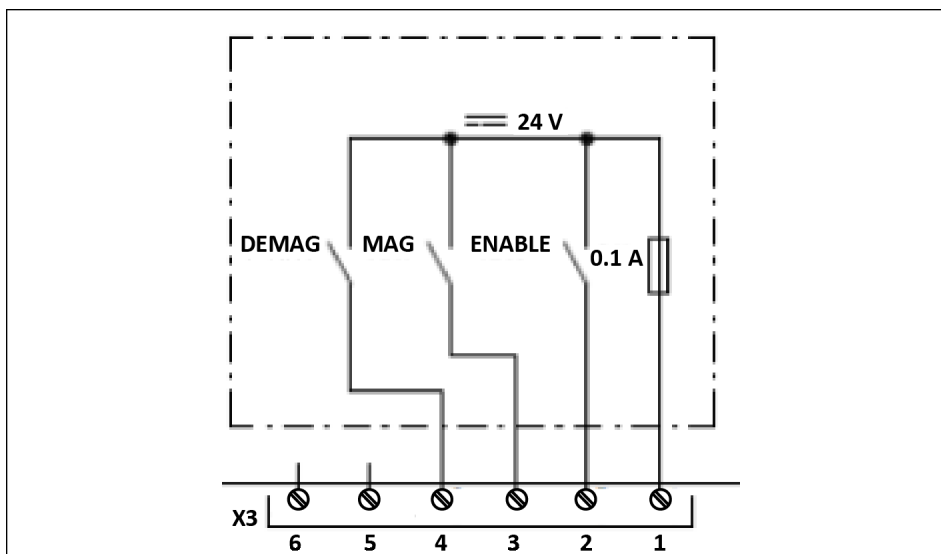

Terminal	Description
1	+24 VDC Connection 24 VDC
2	ENABLE Enable contact magnetic gripper actuation
3	MAG Magnetizing contact (impulse input min. 100 ms)
4	DEMAG Demagnetizing contact (impulse input min. 100 ms)
5	REF DO NOT ASSIGN! (Service connection)
6	0 V GND

- Connect the terminals of the X3 strip to the PLC or to the robot controller.

5.2.2.4 Magnet status terminal (X1)

The status outputs of the magnetic system are connected to the "Display magnet status" terminal (X1).

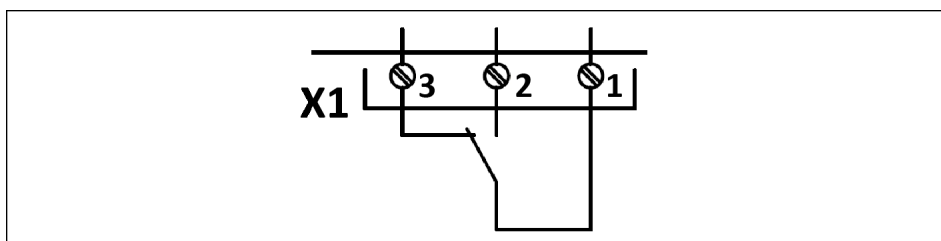

Terminal	Description
1	COM Communication contact, shared connection
2	NO Normally open contact in the event of a demagnetized system
3	NC Normally closed contact in the event of a demagnetized system

- The terminal strip X1 provides feedback on the magnetic status to the higher-level control unit. These terminals must also be connected to the PLC or the robot controller. Use of these pins is useful, but optional. The controller also works without connecting this series of connections.

5.2.3 ECG-R terminal configuration

5.2.3.1 Jumper operating voltage

NOTE

The operating voltage is preset and may only be changed by SCHUNK.

If the operating voltage is changed retroactively, contact SCHUNK.

5.2.3.2 Terminals in power area (L1, L2, U1, V1)

The voltage supply and the magnetic gripper power is connected to the following terminals:

Terminal	Description
L1	Input voltage phase 1
L2	Input voltage phase 2
U1	Supply voltage magnetic gripper
V1	Supply voltage magnetic gripper

- Connect terminals L1 and L2 to one of the 400 V AC cables from the supply cable.
- Connect terminals U1 and V1 to the magnetic unit using one of the cables from the connection cable.
- Connect the PE cable. A neutral conductor is not required.

5.2.3.3 Control terminal (X3)

The signal lines are connected to the "Control" terminal (X3).

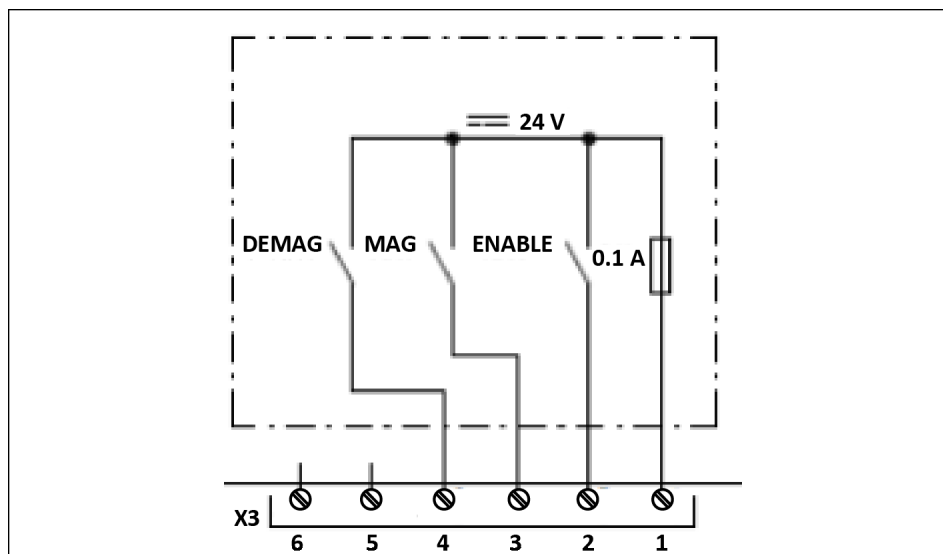

Terminal	Description
1	+24 VDC Connection 24 VDC
2	ENABLE Enable contact magnetic gripper actuation
3	MAG Magnetizing contact (impulse input min. 100 ms)
4	DEMAG Demagnetizing contact (impulse input min. 100 ms)
5	REF DO NOT ASSIGN! (Service connection)
6	0 V GND

- Connect the terminals of the X3 strip to the PLC or to the robot controller.

5.2.3.4 Terminal holding force (X1, supplementary printed circuit board)

The holding force level is preselected via the "holding force" (X1) terminal.

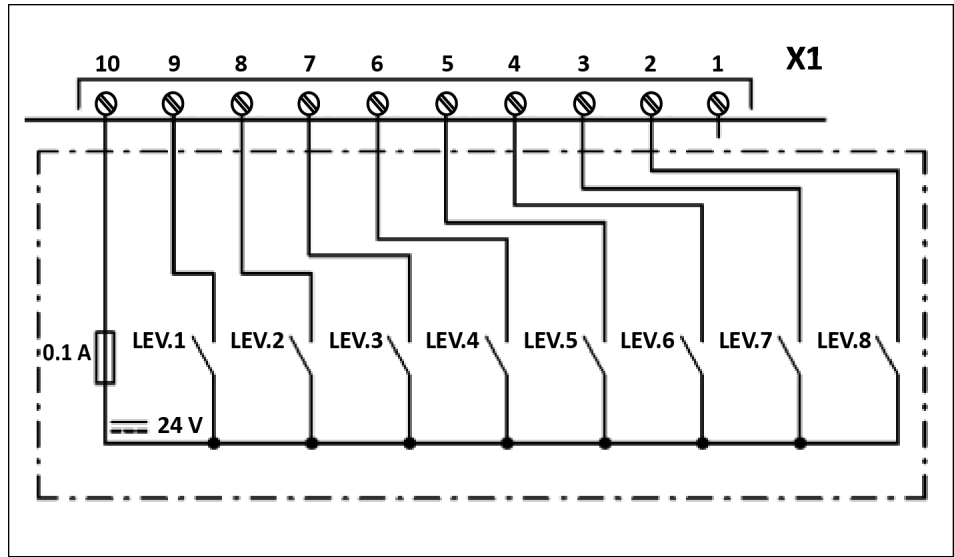

Pin	Description
1	0V GND
2-9	IN1-IN8 Preselection holding force level 1-8
10	+24 VDC Connection 24 VDC

- Connect the terminals of the X1 strip to the PLC or to the robot controller.

Pin	Level 1	Level 2	Level 3	Level 4	Level 5	Level 6	Level 7	Level 8
9	CLOSE	OPEN	OPEN	OPEN	OPEN	OPEN	OPEN	OPEN
8	OPEN	CLOSE	OPEN	OPEN	OPEN	OPEN	OPEN	OPEN
7	OPEN	OPEN	CLOSE	OPEN	OPEN	OPEN	OPEN	OPEN
6	OPEN	OPEN	OPEN	CLOSE	OPEN	OPEN	OPEN	OPEN
5	OPEN	OPEN	OPEN	OPEN	CLOSE	OPEN	OPEN	OPEN
4	OPEN	OPEN	OPEN	OPEN	OPEN	CLOSE	OPEN	OPEN
3	OPEN	OPEN	OPEN	OPEN	OPEN	OPEN	CLOSE	OPEN
2	OPEN	OPEN	OPEN	OPEN	OPEN	OPEN	OPEN	CLOSE

Tab.: Selection of the holding force level (level 1 = minimum holding force level, level 8 = maximum holding force level)

5.2.3.5 Magnet status terminal (X1)

The status outputs of the magnetic system are connected to the "Display magnet status" terminal (X1).

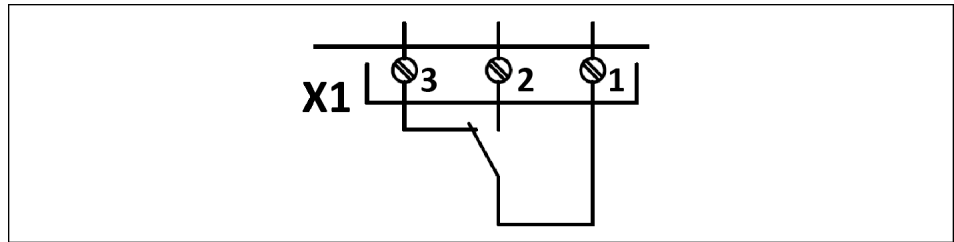

Terminal	Description
1	COM Communication contact, shared connection
2	NO Normally open contact in the event of a demagnetized system
3	NC Normally closed contact in the event of a demagnetized system

- The terminal strip X1 provides feedback on the magnetic status to the higher-level control unit. These terminals must also be connected to the PLC or the robot controller. Use of these pins is useful, but optional. The controller also works without connecting this series of connections.

5.2.4 ECG-W terminal configuration

5.2.4.1 Jumper operating voltage

NOTE

The operating voltage is preset and may only be changed by SCHUNK.

If the operating voltage is changed retroactively, contact SCHUNK.

5.2.4.2 External terminals power area

The voltage supply (1) and the power for the magnetic gripper (2) are connected to the external terminals on the left side of the magnetic gripper. The relay (3) is used to separate the magnetic gripper completely from the product in order to protect it from overvoltages, welding currents, etc.

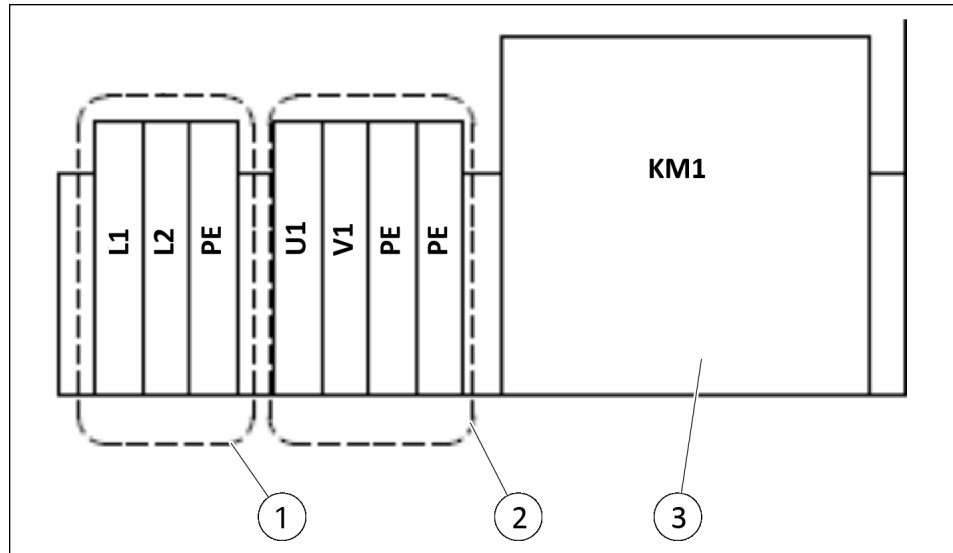

Terminal	Description
L1	Input voltage phase 1
L2	Input voltage phase 2
U1	Supply voltage magnetic gripper
V1	Supply voltage magnetic gripper

5.2.4.3 External terminals actuation area

The actuation signals are connected to the external terminals on the right side of the product.

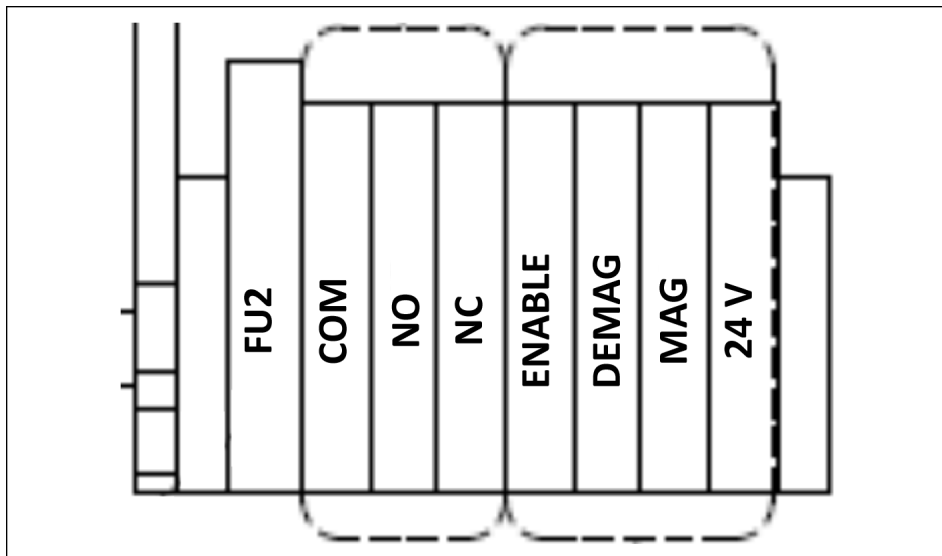

Terminal	Description
FU2	Current circuit fuse protection
COM	Communication contact, shared connection
NO	Normally open contact in the event of demagnetized system
NC	Normally closed contact in the event of demagnetized system
ENABLE	Enable contact magnetic gripper actuation
DEMAG	Demagnetizing contact (impulse input min. 100 ms)
MAG	Magnetizing contact (impulse input min. 100 ms)
24 V	Connection 24 VDC

5.2.5 ECG-C wiring diagram

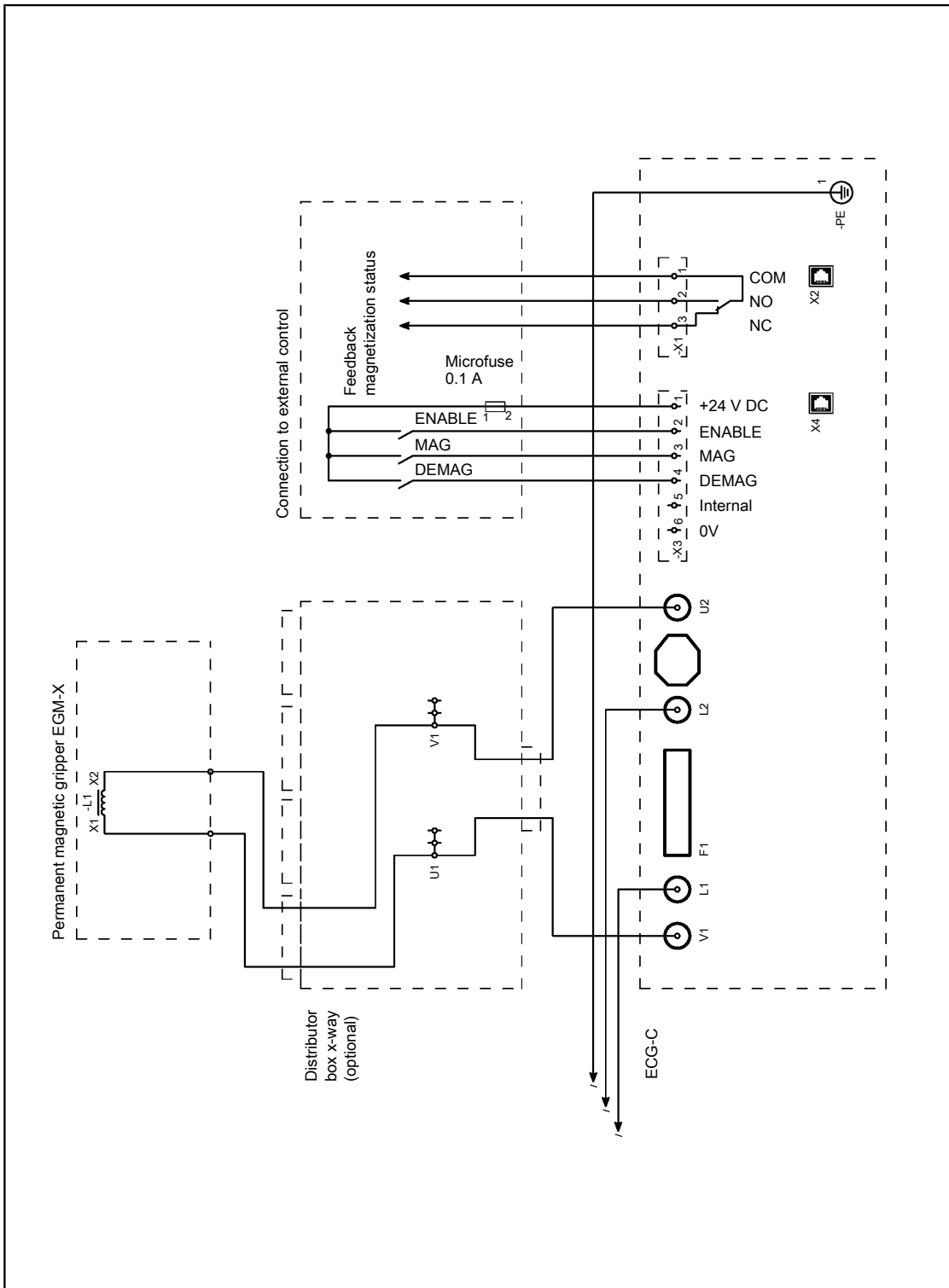

ECG-C 0... wiring diagram

5.2.6 ECG-R wiring diagram

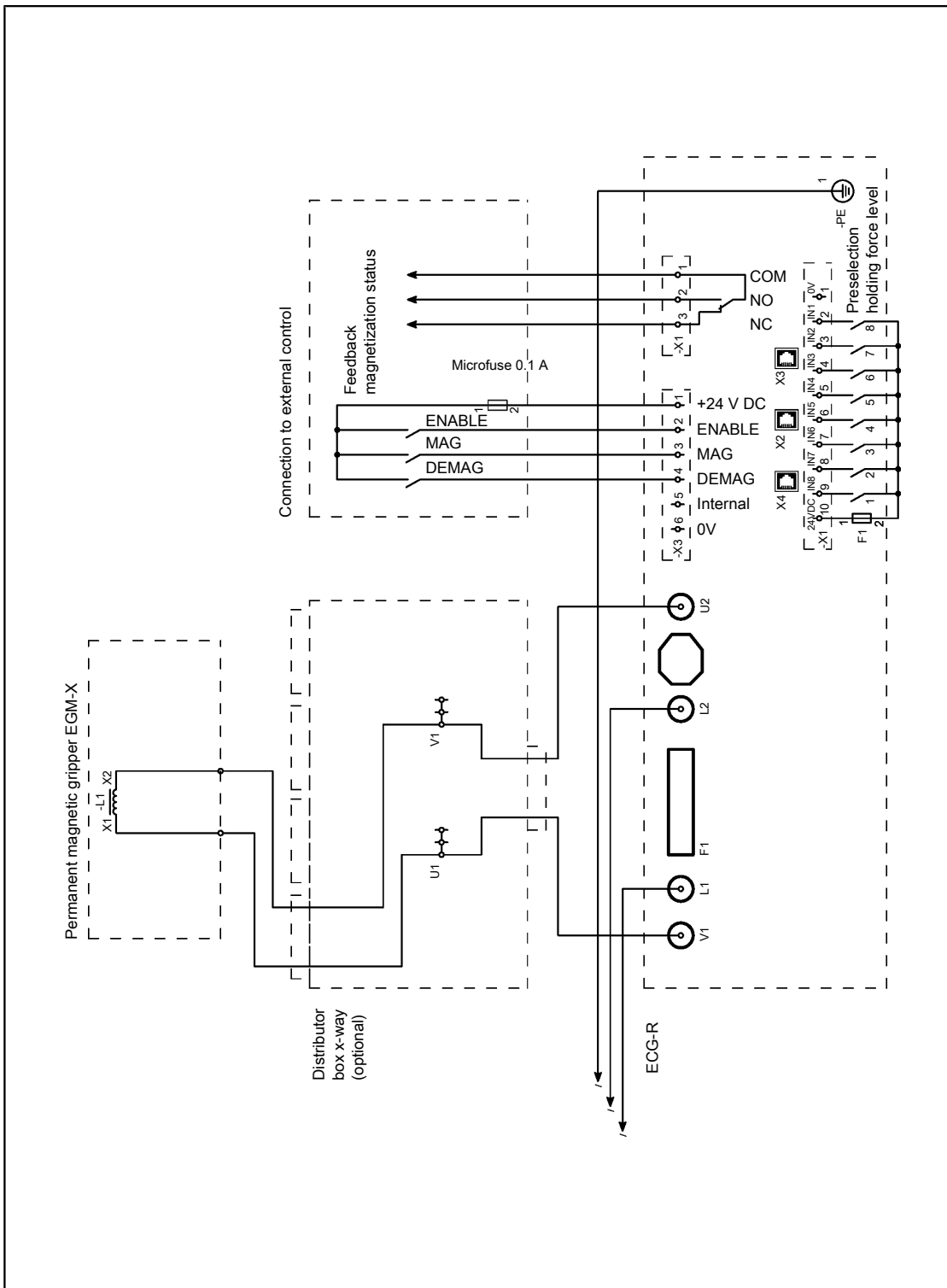

ECG-R 0... wiring diagram

5.2.7 ECG-W wiring diagram

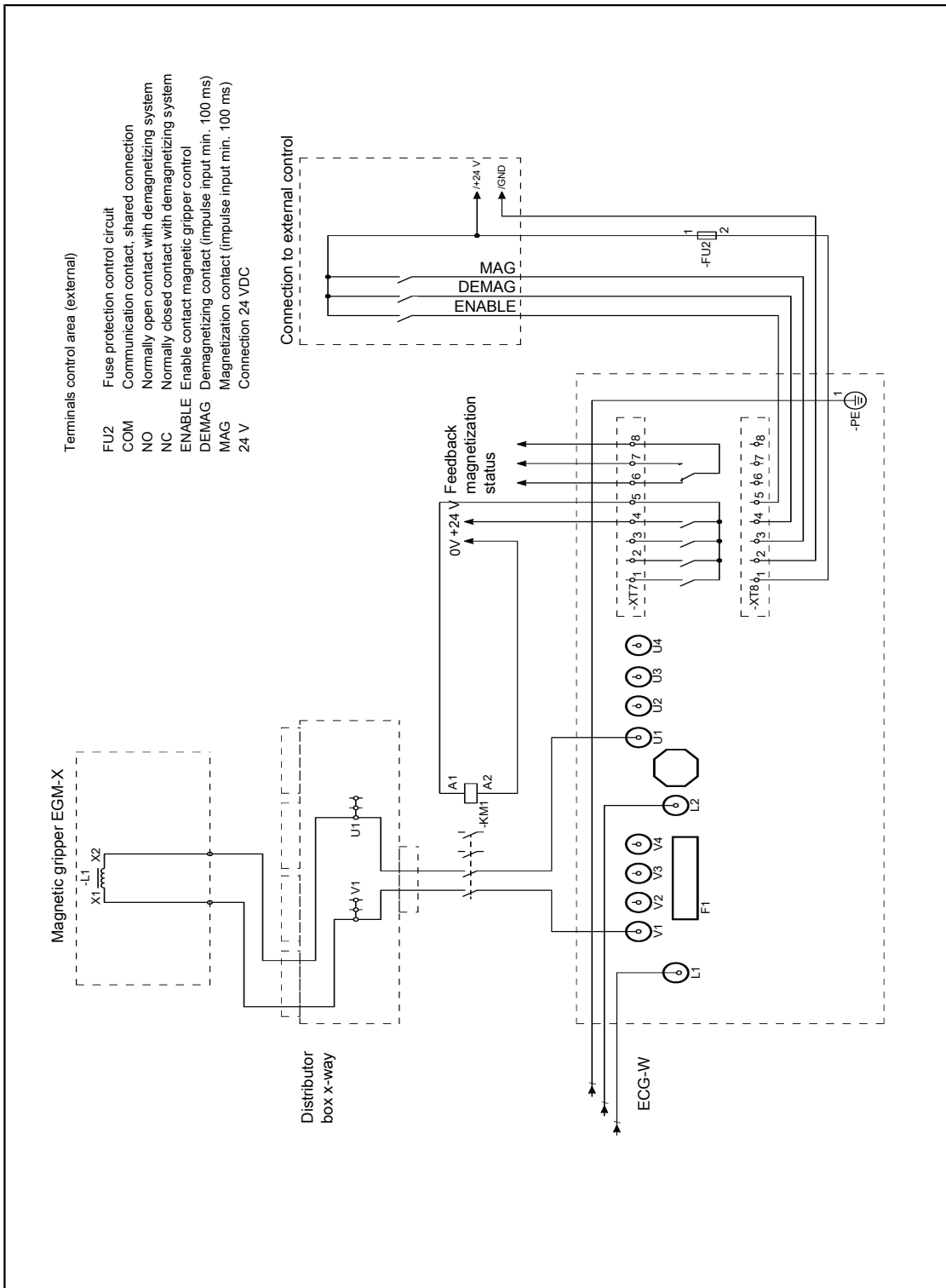

ECG-W 0... wiring diagram

5.2.8 Manual operating unit (optional)

5.2.8.1 Connect manual operating unit



⚠ DANGER

Danger of death from falling workpieces!

Unexpected actuation in parallel with manual operation can lead to a loss of the workpiece and serious injuries.

- Exclude parallel actuation via the higher-level controller for the duration of manual operation.

1. De-energize the product or system.
2. Open the product cover by removing the fastening screws on the cover.
3. Terminal X2: Connect manual operating unit
Note ECG-R: To do this, disconnect the existing cable connection between X1 on the supplementary printed circuit board and terminal X2.
4. Close the product cover and secure it with the fastening screws.

5.2.8.2 Setting up the holding process with the manual operating unit

NOTE

The manual operating unit makes it easy to set up the holding process. Permanent operation of the magnetic gripper using the manual operating unit is not permissible.

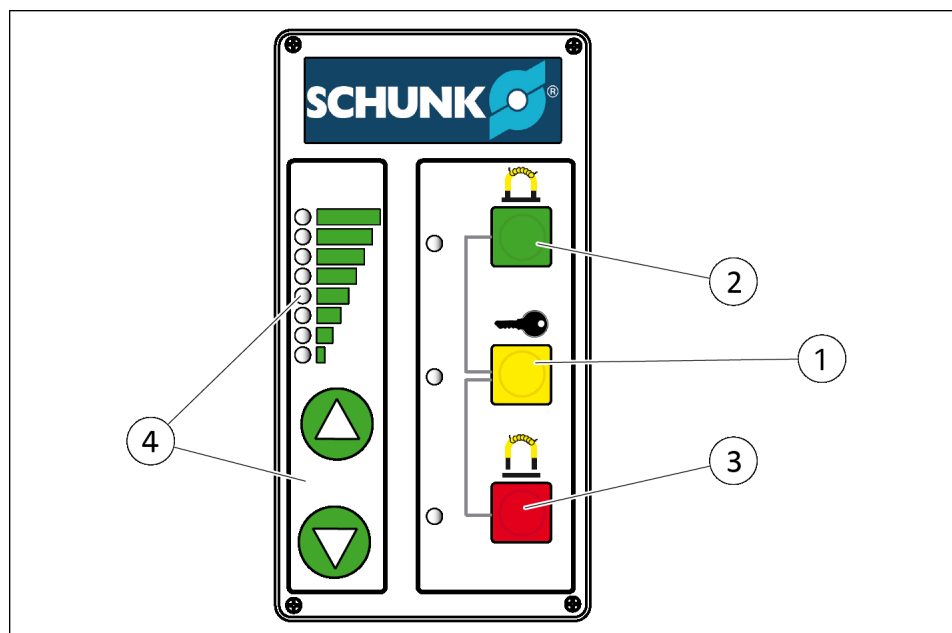

Manual operating unit

Item	Designation	Function
1	Button & LED "Enable"	Enable buttons "Magnetization" (2) and "Demagnetization" (3); do this by holding down the button. The LED lights up as soon as the selected operation is complete.
2	Button & LED "Magnetization"	Perform magnetization; to do this press the button at the same time as the "Enable" (1) button. The LED lights up as soon as the magnetic gripper is magnetized.
3	Button & LED "Demagnetization"	Perform demagnetization; to do this press the button at the same time as the "Enable" (1) button. The LED lights up as soon as the magnetic gripper is demagnetized.
4	Buttons & LEDs "Holding force level"	(Only ECG-R.) Use the arrow buttons to preselect the holding force level. Depending on your selection, up to 8 LEDs will light up.

- LED "Enable" and LED "Demagnetization" light up.
- Manual operating unit is connected to the product.
- 1. Position the magnetic gripper on the workpiece.
- 2. Press the "Enable" and "Magnetization" buttons at the same time.
 - ⇒ The magnetization operation is performed.
 - ⇒ LED "Demagnetization" and LED "Enable" go out.
 - ⇒ LED "Magnetization" lights up.
- 3. Move and set down the workpiece.
- 4. Press the "Enable" and "Demagnetization" buttons at the same time.
 - ⇒ The demagnetization operation is performed.
 - ⇒ LED "Magnetization" and LED "Enable" go out.
 - ⇒ LED "Demagnetization" lights up.
- 5. Remove the workpiece from the magnetic gripper.

6 Commissioning

- Observe all notes in this chapter when commissioning and making adjustments on the system side of the product.



⚠ DANGER

Danger from electric voltage!

Touching live parts may result in death.

- Switch off the power supply before any assembly, adjustment or maintenance work and secure against being switched on again.
- Only qualified electricians may perform electrical installations.
- Check if de-energized, ground it and hot-wire.
- Cover live parts.



⚠ DANGER

Risk of injury due to magnetic fields!

The integrated electric permanent magnets can pose a risk to people with an active or passive implant.

- People with pacemakers or active or passive implants are prohibited from entering the area of the magnetic field.



⚠ WARNING

Danger of crushing due to magnetically attracted tools!

Tools may be attracted by strong magnetic fields and cause severe injuries.

- Only work in deactivated and demagnetized state.



⚠ WARNING

Risk of burns through contact with hot surfaces!

Surfaces of components can heat up severely during operation. Skin contact with hot surfaces causes severe burns to the skin.

- For all work in the vicinity of hot surfaces, wear safety gloves.
- Before carrying out any work, make sure that all surfaces have cooled down to the ambient temperature.



⚠ WARNING

Risk of injury due to loss of workpiece!

A holding force that is too low can lead to the loss of a workpiece and serious injuries during handling.

- Test workpiece suitability for each type of workpiece separately.
- Increase the holding force if necessary.
- Observe the maximum permissible load capacity, ▶ 3 [13].
- Avoid overheating the product. If necessary, reduce the number of activations per minute.

6.1 Adjusting the holding force

(Only ECG-R.)

The holding force required on the magnetic gripper is preselected before every magnetization. To do this, the force signals IN1 – IN8 are activated (value = 1) or deactivated (value = 0) on the "Holding force" terminal (X1, supplementary printed circuit board).

6.2 Chronological sequence of the control and status signals

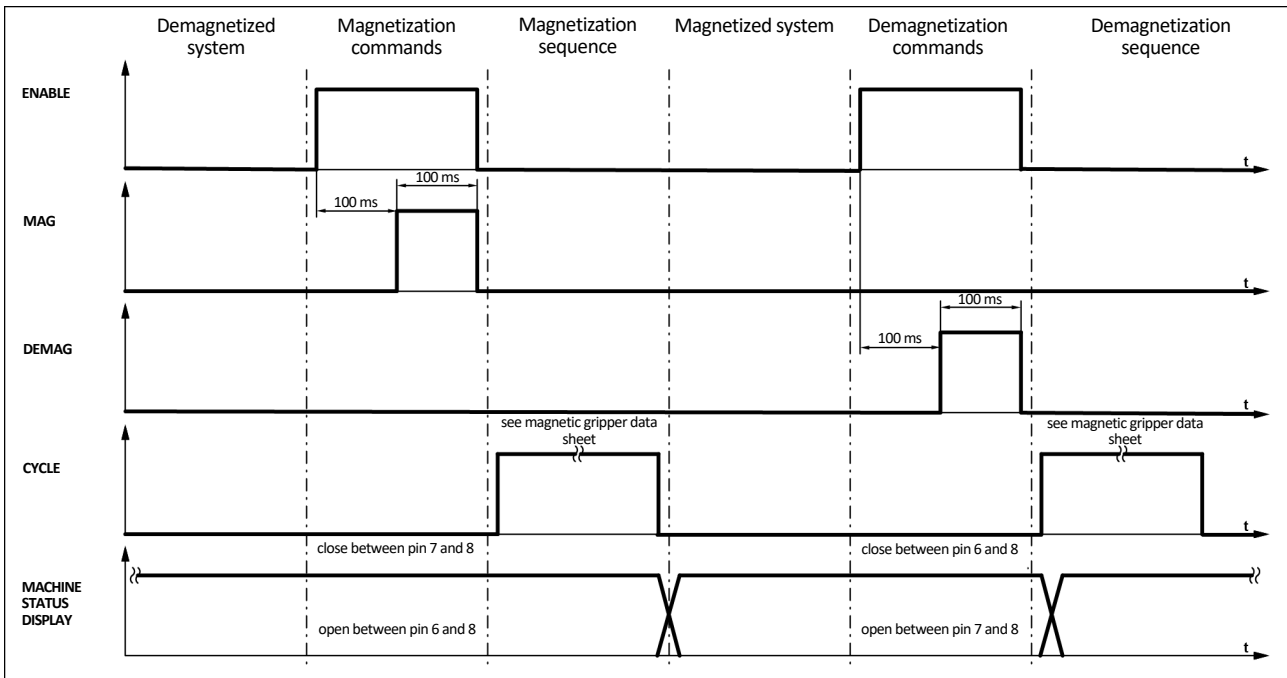

Sequence of the control and status signals

7 Troubleshooting

7.1 Product remains inoperable even after the power supply is turned on

Possible cause	Corrective action
Cable connected incorrectly.	Check connection. Check control cabinet.
Fuses trip.	Check fuses and cables of the product.
Fault circuit interrupter trips.	Check magnetic gripper connection to ground connection.
Mains voltage or frequency differ from ECG setting.	Contact the SCHUNK contact person.
Magnetic gripper and ECG are not compatible.	Check compatibility for max. permitted number of magnetic grippers and max. permitted cable length (20 m) to the magnetic gripper (see catalog datasheet EGM).

7.2 Workpiece disengages from the magnetic gripper.

Possible cause	Corrective action
Product is not performing the magnetization or demagnetization process at all or not correctly.	Check the product, cables and connections for damage.
	Check the activation times and correct if necessary. Before magnetization, the magnetic surface must lie completely against the workpiece.
	Check the type (ramp) and duration of commands and correct if necessary, ▶ 6.2 [36]
The holding force is not sufficient.	Pay attention to instructions on workpiece suitability and holding force in the documentation of the magnetic gripper.
	Only ECG-R: Select a higher holding force level and repeat the magnetization process, ▶ 6.1 [36].

7.3 Demagnetization was not performed correctly.

Possible cause	Corrective action
External grid disturbances impair product functionality.	Install a power line filter upstream of the product.
Lack of actuation or incorrect command sequence.	Check required signals.

8 Maintenance

8.1 Maintenance intervals

NOTE

Any repair work on the product or accessories may only be carried out by SCHUNK.

Maintenance interval	Maintenance work
Regular	Check product for damage and replace if necessary.
As required	Clean the product dry.

8.2 Check and repair the product

NOTICE**Damage caused by faulty disassembly and assembly!**

Incorrect disassembly and assembly can cause damage to the product and/or accessories.

- The product and/or accessories may only be checked and repaired by SCHUNK.
-

9 EU Declaration of Conformity

Manufacturer/ Distributor	SCHUNK SE & Co. KG Spanntechnik Greiftechnik Automatisierungstechnik Bahnhofstr. 106 – 134 D-74348 Lauffen/Neckar
Product designation:	Controller for electro-permanent magnetic gripper EGM ECG
ID number	306300, 306301, 306390, 306391, 306395, 306396

We hereby declare that the product complies with all relevant harmonization legislation of the following directives at the time of declaration.

The declaration is rendered invalid if modifications are made to the product.

- **Electromagnetic compatibility (EMC directive) 2014/30/EU**
- **Low Voltage Directive 2014/35/EU**
- **RoHS directive 2011/65/EU**

Applied harmonized standards, especially:

EN 60204-1: 2006-09 + A1: 2009-02	Safety of machinery – Electrical equipment of machines
EN IEC 61000-6-2:2019	Electromagnetic compatibility (EMC) – Part 6-2: Generic standards – Immunity standard for industrial environments
EN 61000-6-4:2007 + A1:2011	Electromagnetic compatibility (EMC) – Part 6-4: Generic standards – Emission standard for industrial environments (IEC 61000-6-4:2006 + A1:2010);

Signed for and on behalf of: SCHUNK SE & Co. KG

Signature: see original declaration

Dr.-Ing. Manuel Baumeister, Head of Systems
Engineering, Technology & Innovation

Lauffen/Neckar, November 2022

10 UKCA declaration of Conformity

Manufacturer/
Distributor SCHUNK Intec Limited
 Clamping and gripping technology
 3 Drakes Mews, Crownhill
 MK8 0ER Milton Keynes

Product designation: Controller for electro-permanent magnetic gripper EGM ECG
ID number 306300, 306301, 306390, 306391, 306395, 306396

We hereby declare on our sole authority that the product meets the requirements of the following directives at the time of the declaration.

The declaration is rendered invalid if modifications are made to the product.

- **Electromagnetic Compatibility Regulations 2016**
- **Low Voltage Directive 2014/35/EU**
- **RoHS Directive 2011/65/EU**

Applied harmonized standards, especially:

EN IEC 61000-6-2:2019 Electromagnetic compatibility (EMC) – Part 6-2:
 Generic standards – Immunity standard for industrial environments

EN IEC 61000-6-4:2019 Electromagnetic compatibility (EMC) – Part 6-4:
 Generic standards – Emission standard for industrial environments

Person authorized to compile the technical documentation:
Marcel Machado, address: refer to manufacturer's address

Signed for and on behalf of: SCHUNK SE & Co. KG



Lauffen/Neckar, November 2022

Dr.-Ing. Manuel Baumeister, Head of Systems
Engineering, Technology & Innovation

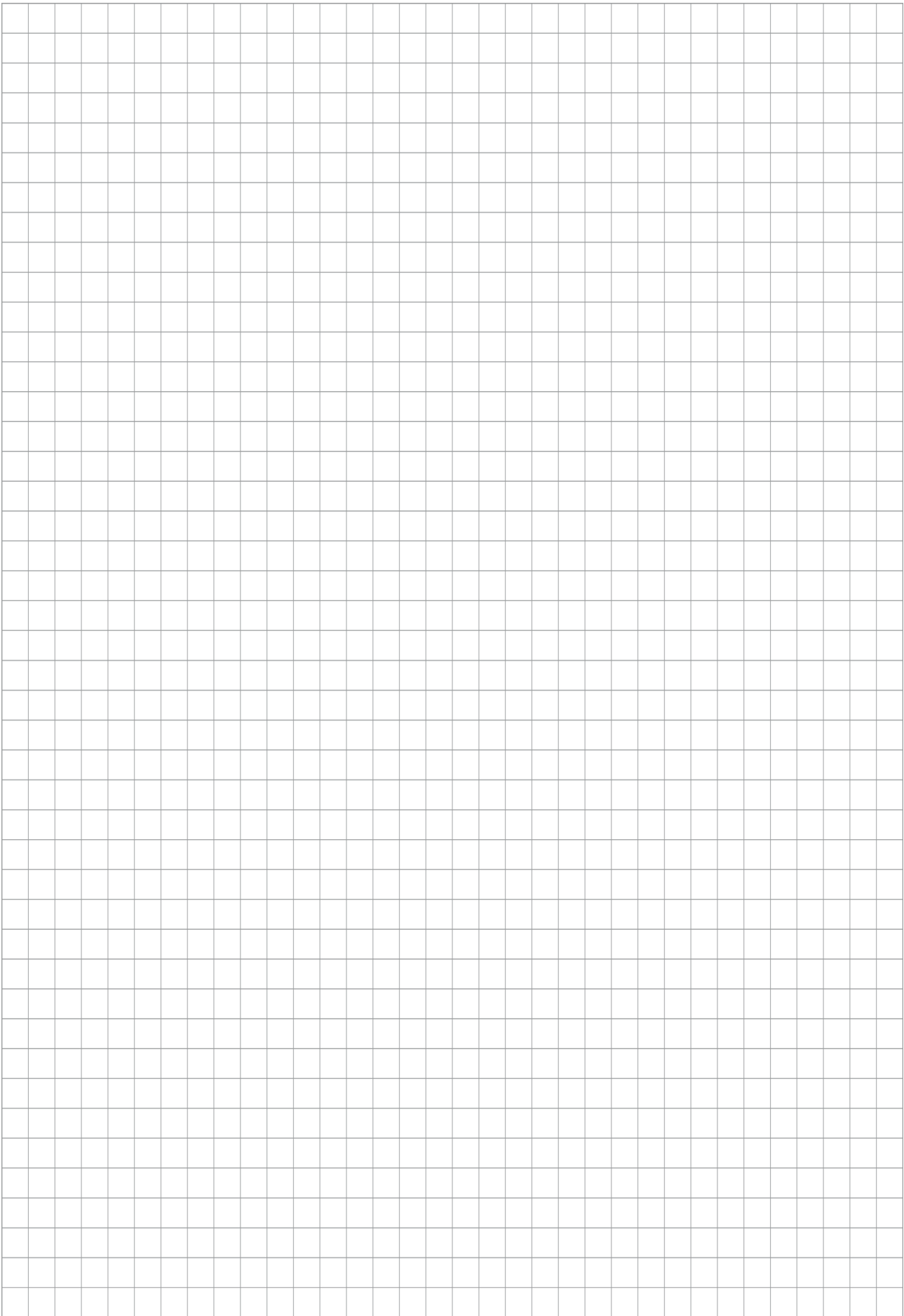







SCHUNK SE & Co. KG
Spanntechnik | Greiftechnik | Automatisierungstechnik

Bahnhofstr. 106 - 134
D-74348 Lauffen/Neckar
Tel. +49-7133-103-0
info@de.schunk.com
schunk.com

Folgen Sie uns | *Follow us*



Wir drucken nachhaltig | *We print sustainable*