



Assembly and Operating Manual

EGM

Electric permanent magnetic gripper

Translation of Original Operating
Manual

Hand in hand for tomorrow

Imprint

Copyright:

This manual is protected by copyright. The author is SCHUNK SE & Co. KG.
All rights reserved.

Technical changes:

We reserve the right to make alterations for the purpose of technical improvement.

Document number: 389539

Version: 03.00 | 21/08/2023 | en

Dear Customer,

Thank you for trusting our products and our family-owned company, the leading technology supplier of robots and production machines.

Our team is always available to answer any questions on this product and other solutions. Ask us questions and challenge us. We will find a solution!

Best regards,

Your SCHUNK team

Customer Management

Tel. +49-7133-103-2503

Fax +49-7133-103-2189

cmg@de.schunk.com



Please read the operating manual in full and keep it close to the product.

Table of Contents

1	General	5
1.1	About this manual.....	5
1.1.1	Presentation of Warning Labels	5
1.1.2	Definition of Terms	5
1.1.3	Applicable documents	6
1.1.4	Sizes.....	6
1.2	Warranty	6
1.3	Scope of delivery.....	6
1.4	Accessories	7
2	Basic safety notes	8
2.1	Appropriate use	8
2.2	Constructional changes.....	8
2.3	Spare parts	9
2.4	Ambient conditions and operating conditions	9
2.5	Personnel qualification	9
2.6	Personal protective equipment	10
2.7	Notes on safe operation.....	11
2.8	Transport.....	11
2.9	Malfunctions	11
2.10	Disposal	12
2.11	Fundamental dangers	12
2.11.1	Protection during handling and assembly	12
2.11.2	Protection during commissioning and operation	13
2.11.3	Protection against dangerous movements	13
2.11.4	Protection against electric shock.....	14
2.11.5	Protection against magnetic and electromagnetic fields	15
3	Technical data	16
3.1	Type key.....	16
3.2	Name plate	17
3.3	Basis data EGM M-Q.....	18
3.4	Basic data EGM M-L	19
3.5	Basic data EGM B-Q	20
3.6	Basic data EGM B-L.....	22
3.7	Connection cable characteristics	23
3.8	Pole extension characteristics (optional).....	23
4	Design and description	24
4.1	Structure	24

4.2	Description	24
4.3	Magnetic suitability of the workpiece material	25
4.4	Factors influencing the holding force.....	26
5	Assembly.....	28
5.1	Installing and connecting	28
5.2	Connections	28
5.2.1	Mechanical connection.....	28
5.2.2	Electrical connection.....	31
5.3	Using the distributor box (optional)	34
5.4	Installing the pole extension (optional)	35
6	Commissioning	37
6.1	General instructions on commissioning.....	38
6.2	Operation with controller ECG-C or ECG-W.....	39
6.3	Operation with controller ECG-R	40
7	Trouble shooting	41
7.1	Product remains inoperable even after the power supply is turned on.....	41
7.2	Workpiece is detached from the product	41
7.3	Demagnetization was not performed correctly	41
8	Maintenance	42
8.1	Maintenance intervals.....	42
8.2	Check and repair the product.....	42
9	EU Declaration of Conformity	43
10	UKCA declaration of Conformity	44
11	Translation of the original declaration of incorporation	45
12	UKCA declaration of incorporation	46

1 General

1.1 About this manual

This manual contains important information for a safe and appropriate use of the product.

This manual is an integral part of the product and must be kept accessible for the personnel at all times.

Before starting work, the personnel must have read and understood this operating manual. Prerequisite for safe working is the observance of all safety instructions in this manual.

In addition to these instructions, the documents listed under ▶ 1.1.3 [6] are applicable.

NOTE: The illustrations in this manual are intended to provide a basic understanding and may deviate from the actual version.

1.1.1 Presentation of Warning Labels

To make risks clear, the following signal words and symbols are used for safety notes.



⚠ DANGER

Dangers for persons!

Non-observance will inevitably cause irreversible injury or death.



⚠ WARNING

Dangers for persons!

Non-observance can lead to irreversible injury and even death.



⚠ CAUTION

Dangers for persons!

Non-observance can cause minor injuries.

CAUTION

Material damage!

Information about avoiding material damage.

1.1.2 Definition of Terms

The term "product" replaces the product name on the title page in this manual.

1.1.3 Applicable documents

- General terms of business *
- Catalog data sheet of the purchased product *
- Assembly and Operating Manual Controller ECG*

The documents labeled with an asterisk (*) can be downloaded from [schunk.com](https://www.schunk.com).

1.1.4 Sizes

This operating manual applies to the following sizes:

- EGM M-Q 30-1
- EGM M-Q 50-1
- EGM M-Q 70-1
- EGM M-L 08-1
- EGM M-L 15-1
- EGM M-L 30-1
- EGM B-Q 50-1x2
- EGM B-Q 50-1x4
- EGM B-Q 50-2x2
- EGM B-Q 70-1x2
- EGM B-Q 70-1x4
- EGM B-Q 70-2x2
- EGM B-L 30-1x2
- EGM B-L 30-1x4

1.2 Warranty

If the product is used as intended, the warranty is valid for 24 months from the ex-works delivery date under the following conditions:

- Observance of the applicable documents
- Observance of the ambient conditions and operating conditions

Parts touching the workpiece and wear parts are not included in the warranty.

1.3 Scope of delivery

The scope of delivery includes

- Electric permanent magnetic gripper EGM in the version ordered

1.4 Accessories

The following accessories, which must be ordered separately, are required for the product:

- Controller ECG
- Power cable

The following accessories are available for the product, which must be ordered separately:

- Manual operating unit
- Pole extension
- Distributor box
- Gauss meter

For information regarding which accessory articles can be used with the corresponding product variants, see catalog data sheet.

2 Basic safety notes

2.1 Appropriate use

The product was designed to safely hold ferromagnetic workpieces.

- The product may only be used within the scope of its technical data, ▶ 3 [16].
- The product is intended for installation in a machine/ automated system. The applicable guidelines for the machine/ automated system must be observed and complied with.
- The product is intended for industrial and industry-oriented use. Its use outside enclosed spaces is only permitted if suitable protective measures are taken against outdoor exposure. The product is not suitable for use in salty air.
- The product can be used within the permissible load limits and technical data for holding workpieces during simple machining operations, but is not a clamping device according to EN 1550:1997+A1:2008.
- When implementing and operating components in safety-related parts of the control systems, the basic safety principles in accordance with DIN EN ISO 13849-2 apply. The proven safety principles in accordance with DIN EN ISO 13849-2 also apply to categories 1, 2, 3 and 4.
- Appropriate use of the product includes compliance with all instructions in this manual.
- Any utilization that exceeds or differs from the appropriate use is regarded as misuse.

2.2 Constructional changes

Implementation of structural changes

By conversions, changes, and reworking, e.g. additional threads, holes, or safety devices can impair the functioning or safety of the product or damage it.

- Structural changes should only be made with the written approval of SCHUNK.

2.3 Spare parts

Use of unauthorized spare parts

Using unauthorized spare parts can endanger personnel and damage the product or cause it to malfunction.

- Use only original spare parts or spares authorized by SCHUNK.

2.4 Ambient conditions and operating conditions

Required ambient conditions and operating conditions

Incorrect ambient and operating conditions can make the product unsafe, leading to the risk of serious injuries, considerable material damage and/or a significant reduction to the product's life span.

- Make sure that the product is used only in the context of its defined application parameters, ▶ 3 [16].
- Make sure that the product is a sufficient size for the application.
- Make sure that the environment is free from splash water and vapors as well as from abrasion or processing dust. Exceptions are products that are designed especially for contaminated environments.

2.5 Personnel qualification

Inadequate qualifications of the personnel

If the personnel working with the product is not sufficiently qualified, the result may be serious injuries and significant property damage.

- All work may only be performed by qualified personnel.
- Before working with the product, the personnel must have read and understood the complete assembly and operating manual.
- Observe the national safety regulations and rules and general safety instructions.

The following personal qualifications are necessary for the various activities related to the product:

Trained electrician

Due to their technical training, knowledge and experience, trained electricians are able to work on electrical systems, recognize and avoid possible dangers and know the relevant standards and regulations.

Qualified personnel	Due to its technical training, knowledge and experience, qualified personnel is able to perform the delegated tasks, recognize and avoid possible dangers and knows the relevant standards and regulations.
Instructed person	Instructed persons were instructed by the operator about the delegated tasks and possible dangers due to improper behaviour.
Service personnel of the manufacturer	Due to its technical training, knowledge and experience, service personnel of the manufacturer is able to perform the delegated tasks and to recognize and avoid possible dangers.

2.6 Personal protective equipment

Use of personal protective equipment

Personal protective equipment serves to protect staff against danger which may interfere with their health or safety at work.

- When working on and with the product, observe the occupational health and safety regulations and wear the required personal protective equipment.
- Observe the valid safety and accident prevention regulations.
- Wear protective gloves to guard against sharp edges and corners or rough surfaces.
- Wear heat-resistant protective gloves when handling hot surfaces.
- Wear protective gloves and safety goggles when handling hazardous substances.
- Wear close-fitting protective clothing and also wear long hair in a hairnet when dealing with moving components.

2.7 Notes on safe operation

Incorrect handling of the personnel

Incorrect handling and assembly may impair the product's safety and cause serious injuries and considerable material damage.

- Avoid any manner of working that may interfere with the function and operational safety of the product.
- Use the product as intended.
- Observe the safety notes and assembly instructions.
- Do not expose the product to any corrosive media. This does not apply to products that are designed for special environments.
- Eliminate any malfunction immediately.
- Observe the care and maintenance instructions.
- Observe the current safety, accident prevention and environmental protection regulations regarding the product's application field.

2.8 Transport

Handling during transport

Incorrect handling during transport may impair the product's safety and cause serious injuries and considerable material damage.

- When handling heavy weights, use lifting equipment to lift the product and transport it by appropriate means.
- Secure the product against falling during transportation and handling.
- Stand clear of suspended loads.

2.9 Malfunctions

Behavior in case of malfunctions

- Immediately remove the product from operation and report the malfunction to the responsible departments/persons.
- Order appropriately trained personnel to rectify the malfunction.
- Do not recommission the product until the malfunction has been rectified.
- Test the product after a malfunction to establish whether it still functions properly and no increased risks have arisen.

2.10 Disposal

Handling of disposal

The incorrect handling of disposal may impair the product's safety and cause serious injuries as well as considerable material and environmental harm.

- Follow local regulations on dispatching product components for recycling or proper disposal.

2.11 Fundamental dangers

General

- Observe safety distances.
- Never deactivate safety installations.
- Install the provided protective product in the danger zone before switching on the product.
- Remove the energy supplies before installation, modification, maintenance, or adjustment work. Ensure there is no residual energy in the system.
- Do not move parts by hand while the energy supply is connected.
- Do not reach into the movement area of the product during operation.

2.11.1 Protection during handling and assembly

Incorrect handling and assembly

Incorrect handling and assembly may impair the product's safety and cause serious injuries and considerable material damage.

- Have all work carried out by appropriately qualified personnel.
- For all work, secure the product against accidental operation.
- Observe the relevant accident prevention rules.
- Use suitable assembly and transport equipment and take precautions to prevent jamming and crushing.

Incorrect lifting of loads

Falling loads may cause serious injuries and even death.

- Stand clear of suspended loads and do not step into their swiveling range.
- Never move loads without supervision.
- Do not leave suspended loads unattended.

2.11.2 Protection during commissioning and operation**Falling or violently ejected components**

Falling and violently ejected components can cause serious injuries and even death.

- Take appropriate protective measures to secure the danger zone.
- Never step into the danger zone during operation.

2.11.3 Protection against dangerous movements**Unexpected movements**

Residual energy in the system may cause serious injuries while working with the product.

- Switch off the energy supply, ensure that no residual energy remains and secure against inadvertent reactivation.
- The faulty actuation of connected drives may cause dangerous movements.
- Operating mistakes, faulty parameterization during commissioning or software errors may trigger dangerous movements.
- Never rely solely on the response of the monitoring function to avert danger. Until the installed monitors become effective, it must be assumed that the drive movement is faulty, with its action being dependent on the control unit and the current operating condition of the drive. Perform maintenance work, modifications, and attachments outside the danger zone defined by the movement range.
- To avoid accidents and/or material damage, human access to the movement range of the machine must be restricted. Limit/prevent accidental access for people in this area due through technical safety measures. The protective cover and protective fence must be rigid enough to withstand the maximum possible movement energy. EMERGENCY STOP switches must be easily and quickly accessible. Before starting up the machine or automated system, check that the EMERGENCY STOP system is working. Prevent operation of the machine if this protective equipment does not function correctly.

2.11.4 Protection against electric shock

Work on electrical equipment

Touching live parts may result in death.

- Work on the electrical equipment may only be carried out by qualified electricians in accordance with the electrical engineering regulations.
- Lay electrical cables properly, e. g. in a cable duct or a cable bridge. Observe standards.
- Before connecting or disconnecting electrical cables, switch off the power supply and check that the cables are free of voltage. Secure the power supply against being switched on again.
- Before switching on the product, check that the protective earth conductor is correctly attached to all electrical components according to the wiring diagram.
- Check whether covers and protective devices are fitted to prevent contact with live components.
- Do not touch the product's terminals when the power supply is switched on.

Possible electrostatic energy

Components or assembly groups may become electrostatically charged. When the electrostatic charge is touched, the discharge may trigger a shock reaction leading to injuries.

- The operator must ensure that all components and assembly groups are included in the local potential equalisation in accordance with the applicable regulations.
- While paying attention to the actual conditions of the working environment, the potential equalisation must be implemented by a specialist electrician according to the applicable regulations.
- The effectiveness of the potential equalisation must be verified by executing regular safety measurements.

2.11.5 Protection against magnetic and electromagnetic fields

Work in areas with magnetic and electromagnetic fields

Magnetic and electromagnetic fields can lead to serious injuries.

- Persons with pace-makers, metal implants, metal shards, or hearing aids require the consent of a physician before entering areas in which components of the electric drive and control systems are mounted, started up, and operated.
- Persons with pace-makers, metal implants, metal shards, or hearing aids require the consent of a physician before entering areas in which magnetic grippers or motor parts with permanent magnets are stored, repaired, or assembled.
- Do not operate high-frequency or radio devices in the proximity of electric components of the drive system and their feed lines.

If the use of such devices is necessary:

When starting up the electric drive and control system, check the machine or automated system for possible failures when such systems are used at different intervals and in different states of the control system. A special additional EMC test may be necessary if the system has a high risk potential.

3 Technical data

3.1 Type key

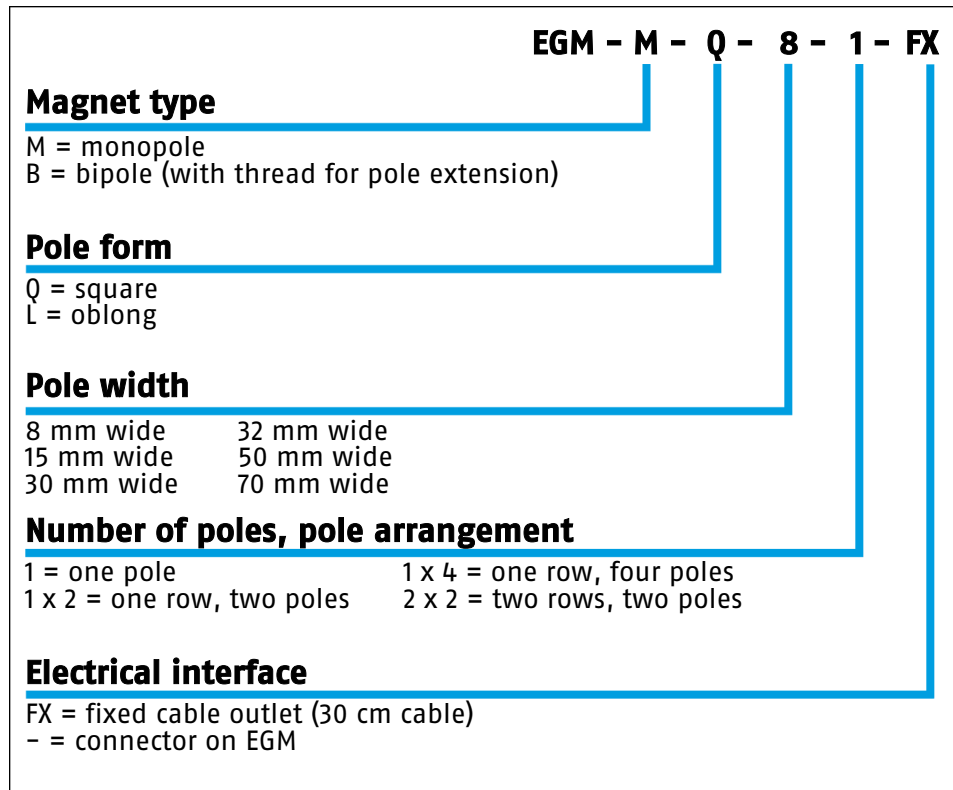

3.2 Name plate

The name plate is located on the side of the controller cover:



Name plate

Information	Description
ID No.	SCHUNK ID no.
Serial no.	Serial no. of the EGM
Work no.	Order no. of the production
Resistance	Rated resistance EGM
Voltage	Rated voltage (mains)
Frequency	Rated frequency (mains)
Current	Rated current (mains)
Year	Year of manufacture
Weight	weight

Do not remove the name plate. When consulting with SCHUNK, always specify serial and ID numbers.

3.3 Basis data EGM M-Q

Designation	EGM M-Q		
	30-1-FX	50-1-FX	70-1-FX
Dimension $\varnothing D \times Z$ [mm]	58 x 60	98 x 65	129.5 x 75
Cable length [cm]	30	30	30
Weight [kg]	1.3	3.45	7.1
Magnetic surface [cm ²]	18.4	50.4	98.1
Number of poles	2		
Load capacity * for horizontal magnetic surface [kg]	18	80	165
Load capacity * for vertical magnetic surface [kg]	7	32	65
Minimum workpiece thickness [mm]	6	12	16
Max. activations/minute [RPM]	20	6	10
Increased product temperature ** at 5 / 15 activations per minute [°C]	13 / 33	37 / 80	24 / 53
Current input on activation/deactivation [A]	3	2.3	3.1
Max. permissible product temperature [° C]	+80		
Ambient temperature [°C]			
Min.	+5		
Max.	+50		
Air humidity [%]			
Min.	30		
Max.	80		
Noise emission [dB(A)]	≤ 70		
IP protection class	54		
Permissible controller variant	ECG-C, ECG-W	ECG-C, ECG-W, ECG-R	
Permissible controller size	ECG 01	ECG 02	ECG 02
Max. number EGM per controller	28	26	19

* Full load capacity can only be reached under ideal conditions (material, workpiece density, surface, etc.). In case of questions on dimensioning of load capacity, contact SCHUNK.

** Increased product temperature tested on material 1.0037 with 20 mm workpiece thickness, ground surface and complete coverage of the magnetic surface.

3.4 Basic data EGM M-L

Designation	EGM M-L		
	08-1-FX	15-1-FX	30-1-FX
Dimension X x Y x Z [mm]	98 x 56 x 58	105 x 47 x 79	96 x 66 x 71
Cable length [cm]	30	30	30
Weight [kg]	1	2.1	3.1
Magnetic surface [cm ²]	12	22.5	36.9
Number of poles	2		
Load capacity * for horizontal magnetic surface [kg]	10	22	60
Load capacity * for vertical magnetic surface [kg]	4	9	24
Minimum workpiece thickness [mm]	3	5	10
Max. activations/minute [RPM]	16	16	12
Increased product temperature ** at 5 / 15 activations per minute [°C]	18 / 39	15 / 40	22 / 49
Current input on activation/ deactivation [A]	3.7	2.6	2.2
Max. permissible product temperature [° C]	+80		
Ambient temperature [°C]			
Min.	+5		
Max.	+50		
Air humidity [%]			
Min.	30		
Max.	80		
Noise emission [dB(A)]	≤ 70		
IP protection class	54		
Permissible controller variant	ECG-C, ECG-W	ECG-C, ECG-W, ECG-R	
Permissible controller size	ECG 01	ECG 02	ECG 02
Max. number EGM per controller	23	17	32

* Full load capacity can only be reached under ideal conditions (material, workpiece density, surface, etc.). In case of questions on dimensioning of load capacity, contact SCHUNK.

** Increased product temperature tested on material 1.0037 with 20 mm workpiece thickness, ground surface and complete coverage of the magnetic surface.

3.5 Basic data EGM B-Q

Designation	EGM B-Q		
	50-1x2	50-1x4	50-2x2
Dimension X x Y x Z [mm]	170 x 95 x 61	290 x 95 x 61	170 x 150 x 61
Weight [kg]	5.5	13	8.5
Magnetic surface [cm ²]	50	100	
Number of poles	2	4	
Load capacity * for horizontal magnetic surface [kg]	75	175	
Load capacity * for vertical magnetic surface [kg]	30	70	
Minimum workpiece thickness [mm]	12	14	
Max. activations/minute [RPM]	20	8	
Increased product temperature ** at 5 / 15 activations per minute [°C]	12 / 30	30 / 68	
Current input on activation/ deactivation [A]	2.9	9.5	
Max. permissible product temperature [° C]	+80		
Ambient temperature [°C]			
Min.	+5		
Max.	+50		
Air humidity [%]			
Min.	30		
Max.	80		
Noise emission [dB(A)]	≤ 70		
IP protection class	52		
Permissible controller variant	ECG-C, ECG-W, ECG-R		
Permissible controller size	ECG 02		
Max. number EGM per controller	25	7	

Designation	EGM B-Q		
	70-1x2	70-1x4	70-2x2
Dimension X x Y x Z [mm]	210 x 115 x 61	370 x 115 x 61	210 x 195 x 61
Weight [kg]	9	25	15
Magnetic surface [cm ²]	98	196	
Number of poles	2	4	
Load capacity * for horizontal magnetic surface [kg]	120	296	290
Load capacity * for vertical magnetic surface [kg]	48	118	115
Minimum workpiece thickness [mm]	14	18	
Max. activations/minute [RPM]	15	10	
Increased product temperature ** at 5 / 15 activations per minute [°C]	15 / 40	24 / 60	
Current input on activation/ deactivation [A]	6.4	12.3	
Max. permissible product temperature [° C]	+80		
Ambient temperature [°C]			
Min.	+5		
Max.	+50		
Air humidity [%]			
Min.	30		
Max.	80		
Noise emission [dB(A)]	≤ 70		
IP protection class	52		
Permissible controller variant	ECG-C, ECG-W, ECG-R		
Permissible controller size	ECG 02		
Max. number EGM per controller	9	4	5

* Full load capacity can only be reached under ideal conditions (material, workpiece density, surface, etc.). In case of questions on dimensioning of load capacity, contact SCHUNK.

** Increased product temperature tested on material 1.0037 with 20 mm workpiece thickness, ground surface and complete coverage of the magnetic surface.

3.6 Basic data EGM B-L

Designation	EGM B-L	
	30-1x2	30-1x4
Dimension X x Y x Z [mm]	190 x 75 x 61	330 x 75 x 61
Weight [kg]	6.5	11.5
Magnetic surface [cm ²]	36	72
Number of poles	2	4
Load capacity * for horizontal magnetic surface [kg]	60	110
Load capacity * for vertical magnetic surface [kg]	20	40
Minimum workpiece thickness [mm]	8	
Max. activations/minute [RPM]	15	20
Increased product temperature ** at 5 / 15 activations per minute [°C]	15 / 35	12 / 32
Current input on activation/ deactivation [A]	3.1	6.5
Max. permissible product temperature [° C]	+80	
Ambient temperature [°C]		
Min.	+5	
Max.	+50	
Air humidity [%]		
Min.	30	
Max.	80	
Noise emission [dB(A)]	≤ 70	
IP protection class	52	
Permissible controller variant	ECG-C, ECG-W, ECG-R	
Permissible controller size	ECG 02	
Max. number EGM per controller	24	13

* Full load capacity can only be reached under ideal conditions (material, workpiece density, surface, etc.). In case of questions on dimensioning of load capacity, contact SCHUNK.

** Increased product temperature tested on material 1.0037 with 20 mm workpiece thickness, ground surface and complete coverage of the magnetic surface.

3.7 Connection cable characteristics

Designation	Value
Characteristics	drag chain compatible, torsion-compatible
Min. bending radius [m]	
moving	10 x cable- \emptyset
fixed	5 x cable- \emptyset
Max. angle of torsion [°/m]	± 180

3.8 Pole extension characteristics (optional)

Designation	Value
Material	Fe 360 UNI 10233/3
Only available for	EGM B-Q and EGM B-L

NOTE

Use of a pole extension reduces the permissible load capacity by up to 75%.

4 Design and description

4.1 Structure

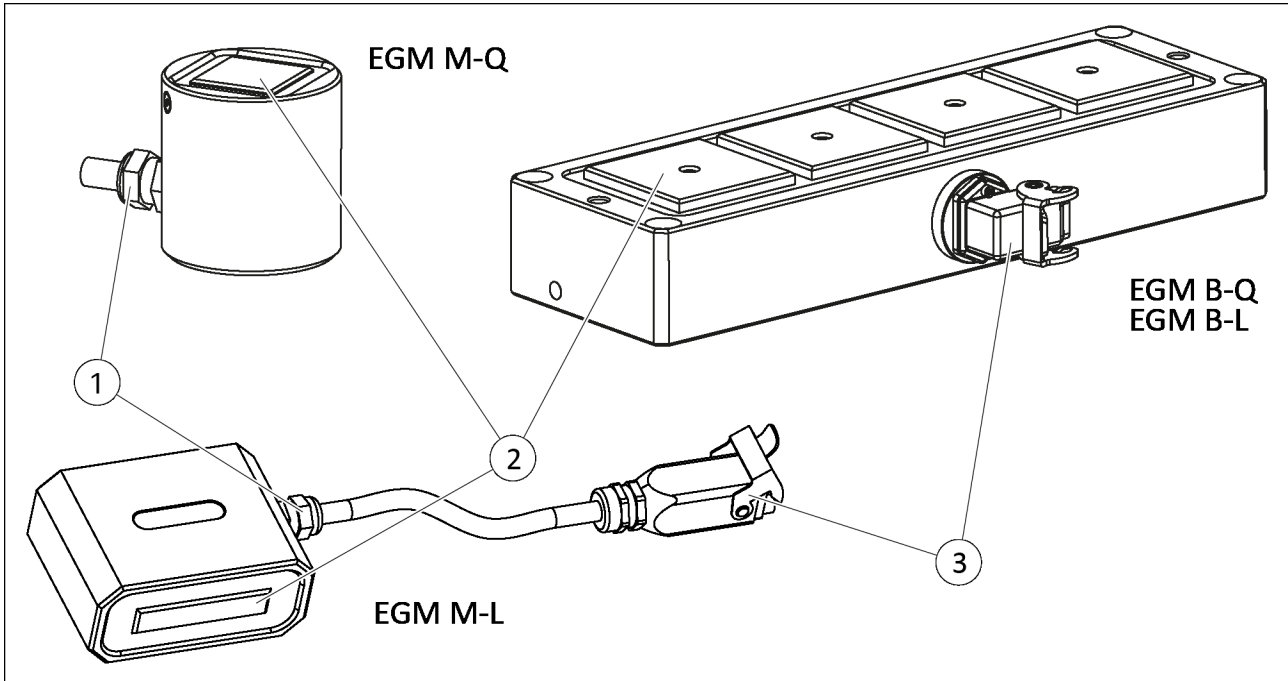

EGM structure (schematic diagram)

- 1 Connection cable, pre-assembled
- 2 Quadratic/oblong magnet poles; for bipolar products with borehole for assembly of a pole extension
- 3 Connecting plug with locking clip

4.2 Description

The product is an electric permanent magnetic gripper for the energy-efficient handling of ferromagnetic workpieces. The workpieces are free from interfering contours allowing access from five sides and are also held reliably in emergency stop scenarios. Various sizes in monopolar and bipolar versions allow operation with different workpieces.

The functional principle is based on the combination of AlNiCo and neodymium magnets: in deactivated state, the magnetic flux of the AlNiCo magnets passes through the neodymium magnets and closes the magnetic circuit via the steel gripper base body. To activate the system, an electric current pulse is conducted through the coil. This reverses the polarity of the AlNiCo magnets so that the magnetic circuit is closed by the ferromagnetic workpiece to be gripped.

The product communicates with the higher-level control via an ECG-type controller. If required, this can also simultaneously actuate several products that are connected e. g. via a distributor box. Depending on the holding force required, select one of the following controller variants:

- EGM-C: Holding force constant
- EGM-R: Holding force selectable (8 holding force levels)
- EGM-W: Holding force constant, optimized for welding applications

For sufficient holding force, the contact surface of the workpiece must be large enough to cover both poles of the product. For round workpieces, this can also be attained by using a pole extension. The permissible load capacity must be adhered to, ▶ 3 [16].

Any residual magnetism remaining in the workpiece (remanence) can be measured with an optionally available gaussmeter.

4.3 Magnetic suitability of the workpiece material

The product is design to hold almost all ferromagnetic materials. The attainable holding force depends on the magnetic resistance and thus on the chemical composition of the respective workpiece material, among other factors. Accordingly, with some ferromagnetic materials a reduction in the nominal holding force of more than 30% can be expected.

The following table shows a few examples of empirical values:

Material	Efficiency
Conventional steel (Fe 360)	100%
Ferromagnetic crude steel (C10 – C15)	90%
Tool, case hardening and sectional steels	70 – 80%
Magnetic stainless steel	65%
Cast iron	50%

In addition, material alloys can cause residual magnetism to remain in the workpiece, which significantly reduces the holding force.

Negative impact of heat treatment processes

Heat treatment processes can substantially change the magnetic characteristics of a ferromagnetic material. When methods such as forging, hardening, tempering or sintering are used, the suitability of the treated workpiece needs to be tested separately.

Examples of unsuitable materials

Handling workpieces made of materials such as the following is not possible:

- Aluminum and its alloys
- Bronze
- Brass
- Non-magnetic cast iron
- Some stainless steels (e.g. austenitic), which are only slightly magnetizable after being hardened by plastic deformation.
- Non-metallic materials

Note: if you have questions about the magnetic suitability of a workpiece, contact SCHUNK.

4.4 Factors influencing the holding force

Apart from the magnetic characteristics of the workpiece material, the attainable holding force is dependent on the following influencing factors:

Dimensions

The contact surface of the workpiece must be large enough to cover at least two poles on the product with different polarity. Only then can the magnetic circuit be closed and the holding force generated.

Contact surface

The attainable holding force is greatest when the contact surface of the workpiece is at least as big as the magnetic surface of the product.

Air gap

Uneven or dirty contact surfaces increase the distance (air gap) between the workpiece and the product. The attainable holding force is greatest when the air gap or its distribution over the contact surface is kept as small as possible. Air gaps also need to be taken into account if, due to production reasons, a higher surface quality cannot be achieved.

Workpiece thickness

For very thin workpieces (e.g. metal sheets) the maximum available holding force cannot be used due to physical reasons. Bending can also reduce the usable contact surface and thus the effect of the holding force. The resulting peeling effects can also counteract the holding force.

Heating

Each activation increases the internal temperature of the product. Overheating reduces the magnetic characteristics and can destroy the product. The following criteria must therefore be met:

- The residual heat of the workpiece corresponds to the permissible ambient temperature, ▶ 3 [16].
- The number of activations per minute is set in such a way that the maximum permissible product temperature is not reached.

Movement energy

When moving the workpiece, acceleration forces counteract the holding force. The forces exerted by the machine/system must be significantly less than the holding force attainable with the respective workpiece.

Note: if you have questions about the holding force, contact SCHUNK.

5 Assembly

5.1 Installing and connecting

1. Check the flatness of the mounting surface, ▶ 5.2.1 [28].
2. Screw the product to the machine/system, ▶ 5.2.1 [28].
3. Connect the power cable and close it with the locking clip of the connecting plug, ▶ 5.2.2 [31].
4. Install the distributor box if necessary and connect to it, ▶ 5.3 [34].
5. **EGM B only:** Install the pole extension if necessary, ▶ 5.4 [35].
6. Connect the product to controller ECG; observe the corresponding operating manual, ▶ 1.1.3 [6].

5.2 Connections

5.2.1 Mechanical connection

Evenness of the mounting surface

The values apply to the whole mounting surface to which the product is mounted.

Edge length	Permissible unevenness
< 100	< 0.02
> 100	< 0.05

Tab.: Requirements for evenness of the mounting surface (Dimensions in mm)

Fastening the EGM M-Q

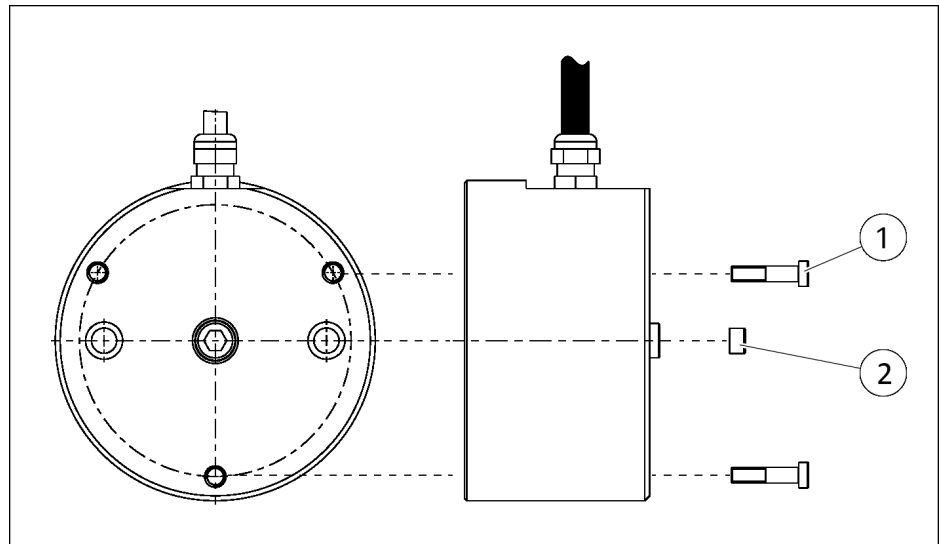

Mechanical connection EGM M-Q (schematic diagram)

Item Designation	EGM-M-Q		
	30-1-FX	50-1-FX	70-1-FX
1 Fastening screw	3 x M6	3 x M6	3 x M8

Fastening EGM M-L

Item Designation	EGM-M-Q		
	30-1-FX	50-1-FX	70-1-FX
Maximum depth of engagement [mm]	10	10	13
Tightening torque [Nm]	10	10	25
2 Centering sleeve	2 x Ø10	2 x Ø10	2 x Ø14

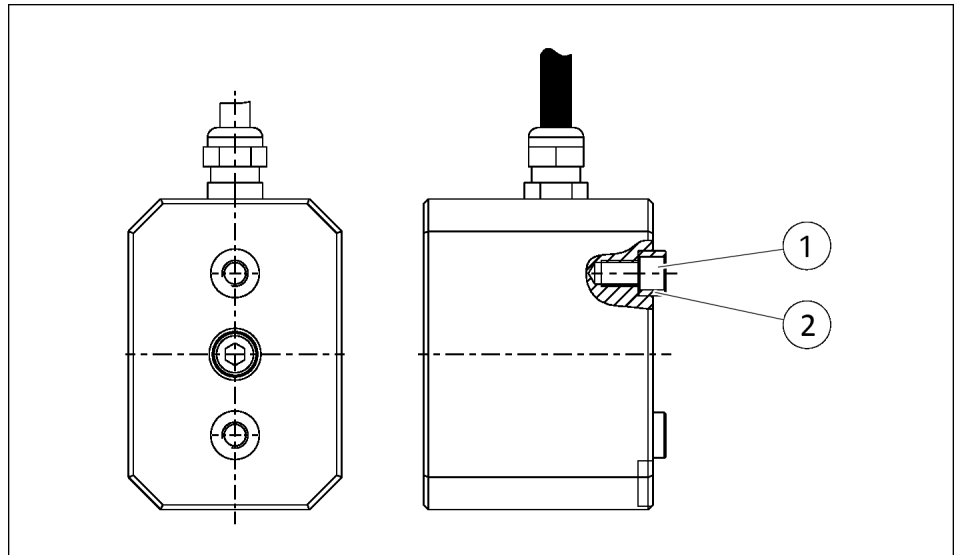

Mechanical connection EGM M-L (schematic diagram)

Item Designation	EGM-M-L		
	08-1-FX	15-1-FX	30-1-FX
1 Fastening screw	2 x M6	2 x M6	2 x M8
Maximum depth of engagement [mm]	14	16	16
Tightening torque [Nm]	10	10	25
2 Centering sleeve	2 x Ø10	2 x Ø10	2 x Ø14

Fastening EGM B-Q

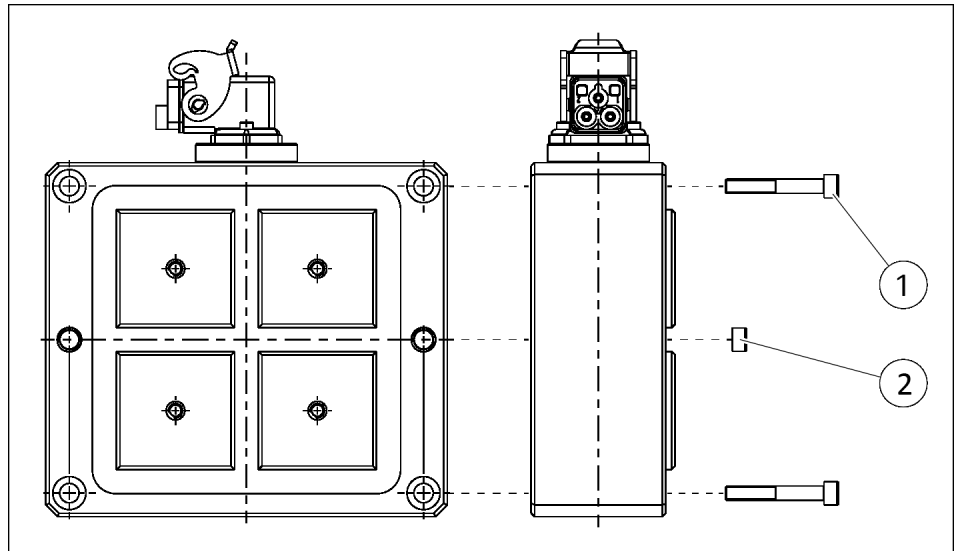

Mechanical connection (schematic diagram using the example EGM B-Q 2x2)

Item Designation		EGM-B-Q		
		50-1x2	50-1x4	50-2x2
1	Fastening screw	4 x M10		
	Maximum depth of engagement [mm]	16		
	Tightening torque [Nm]	49		
2	Centering sleeve	2 x Ø14		

Item Designation		EGM-B-Q		
		70-1x2	70-1x4	70-2x2
1	Fastening screw	4 x M12		
	Maximum depth of engagement [mm]	20		
	Tightening torque [Nm]	85		
2	Centering sleeve	2 x Ø14		

Fastening EGM B-L

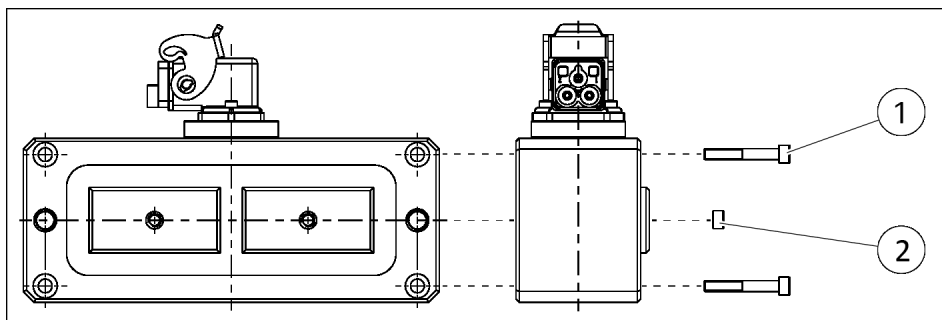

Mechanical connection (schematic diagram using the example EGM B-L 1x2)

Item Designation	EGM-B-L	
	30-1x2	30-1x4
1 Fastening screw	4 x M8	
Maximum depth of engagement [mm]	13	
Tightening torque [Nm]	25	
2 Centering sleeve	2 x Ø14	

5.2.2 Electrical connection



⚠ DANGER

Danger from electric voltage!

Touching live parts may result in death.

- Switch off the power supply before any assembly, adjustment or maintenance work and secure against being switched on again.
- Only qualified electricians may perform electrical installations.
- Check if de-energized, ground it and hot-wire.
- Cover live parts.

CAUTION

Damage due to faulty connection!

A faulty connection can cause damage to the product.

- Observe the pin allocation of the connecting terminals.
- Make sure that all components are grounded correctly.

The product is connected directly or via a distributor box to the controller ECG. A power cable is required for the connection, ▶ 1.4 [7].

- The controller ECG to be connected is disconnected from the electrical network.

1. Connect the socket of the power cable to the product's connecting plug.
2. Close the locking clip on the connecting plug.
3. Install the power cable correctly.
4. Connect the open wire strands of the power cable, ▶ 5.2.2.1 [32]:
 - ⇒ Connect to distributor box, ▶ 5.3 [34].
 - ⇒ Connect to controller, ▶ 1.1.3 [6].

5.2.2.1 Connection assignment of the power cable

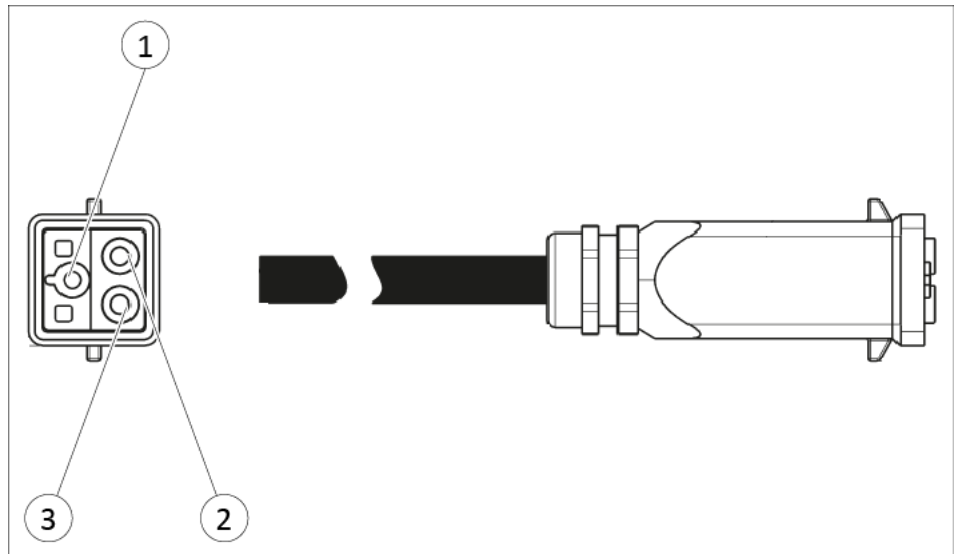

Power cable

Power cable connector			Controller
Pin	Function	Color	Terminal
1	Protective ground	Green/Yellow	PE1
2	Phase 1	Black (1)	U1
3	Phase 2	Black (2)	V1

5.2.2.2 Turning the connecting plug (EGM B only)

The assembly direction of the connection plug can be modified with bipolar products. Eight possible connector positions are available in order to adapt the cable extension to the relevant installation situation:

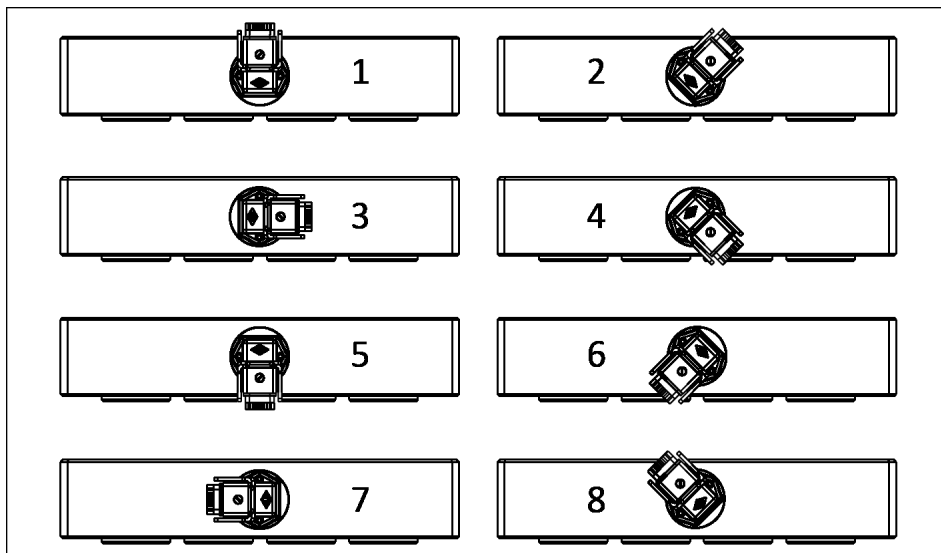

Connector positions

CAUTION

Material damage due to turning the connecting plug too far!

The internal wiring can become loose if the connecting plug is turned by more than 360° compared to its delivery state.

- Turn the connecting plug no more than 315° as far as connector position 8.
- To set a lower connector position, turn the connecting plug in the opposite direction.

1. Loosen both fastening screws of the connecting plug and remove them.
2. Turn the connecting plug to the desired position and insert it.
3. Lock the connecting plug with both fastening screws.

5.3 Using the distributor box (optional)

Using a distributor box, several magnetic grippers can be operated on one controller.

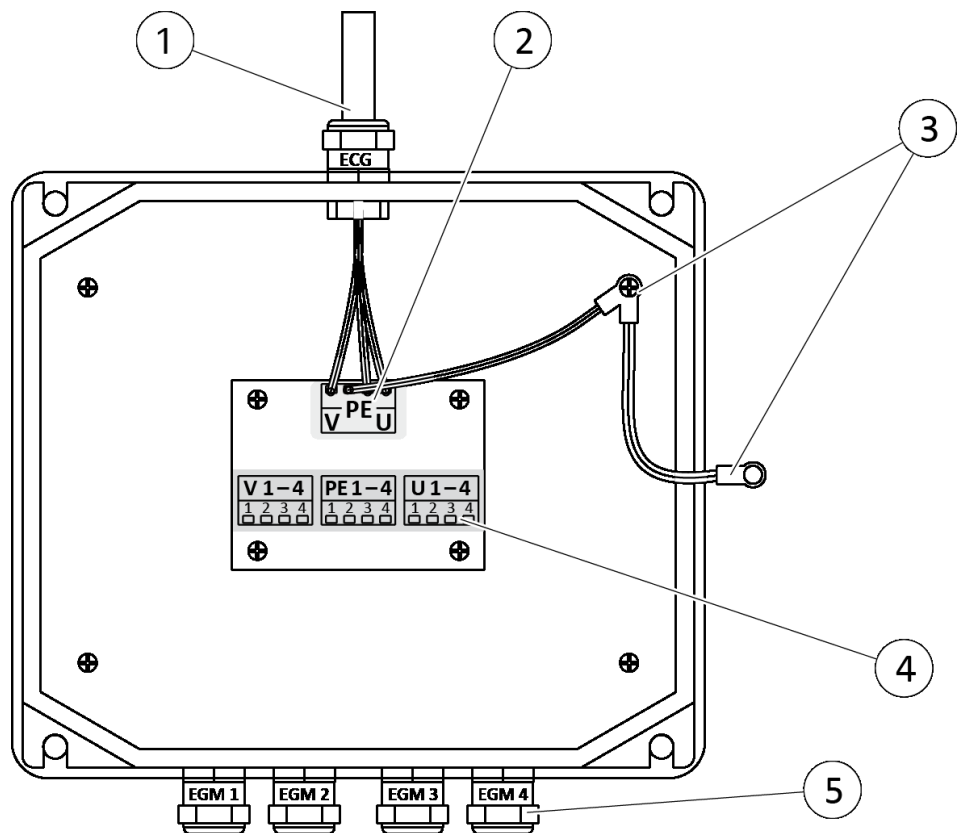

Example: distributor box for four magnetic grippers

- | | |
|---|---|
| 1 | Cable gland, output for power cable to controller |
| 2 | Output terminals [V-PE-U] for the controller connection |
| 3 | Protective cable connection [PE] for grounding of housing and cover |
| 4 | Input terminals [V-PE-U] for connection of magnetic grippers 1 – 4 |
| 5 | Cable glands, input for power cables of magnetic grippers |

- The controller ECG to be connected is disconnected from the electrical network.
- 1. Install the distributor box at a suitable point. Observe the cable lengths.
- 2. Open the cover of the distributor box; on request, detach the protective conductor connection (3) from the cover.
- 3. Detach all the required cable glands.
- 4. Connect the magnetic grippers one after the other:
 - ⇒ Guide the power cable through the cable gland (5) into the distributor box.
 - ⇒ Connect the wires [V-PE-U] to the corresponding input terminals (4), ▶ 5.2.2.1 [32].

- ⇒ Tighten the cable gland (5) until it is hand-tightened.
- ⇒ Repeat the process for additional magnetic grippers.
- 5.** Connect the controller:
 - ⇒ Guide the power cable through the cable gland (1) into the distributor box.
 - ⇒ Connect the wires [V-PE-U] to the output terminals (2).
 - ⇒ Tighten the cable gland (1) until it is hand-tightened.
- 6.** If present, connect the cover with the protective conductor connection (3).
- 7.** Attach the cover on the distributor box and fasten it securely. **IMPORTANT! Make sure the perimeter seal is correctly in place.**

5.4 Installing the pole extension (optional)

NOTE

Use of a pole extension reduces the permissible load capacity by up to 75%.

Pole extensions are only available for bipolar products. The assembly of a pole extension can improve safe holding of round workpieces, for example.

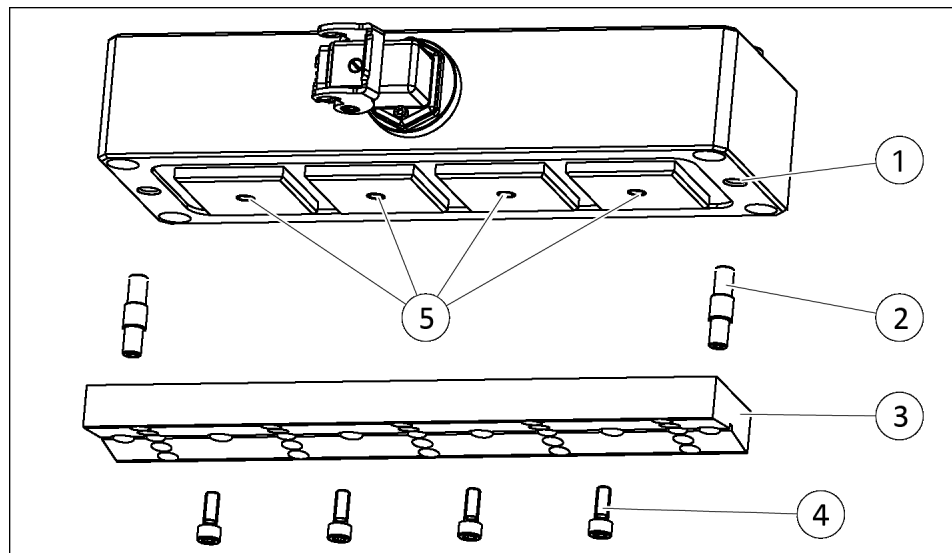

Pole extension (schematic diagram using example EGM B-Q 1x4)

- 1.** For assembly, observe the following dimensions and tightening torques; these are distinguished depending on size.
- 2.** Screw the centering pins (2) into the steel housing of the product (1).
- 3.** Insert the pole extension (3) into the centering pins (2).
- 4.** Screw the pole extension (3) using fastening screws (4) onto the magnetic poles (5).

Fastening to EGM B-Q

Item Designation		EGM B-Q		
		50-1x2	50-1x4	50-2x2
2	Centering pin thread	M10		
	Maximum depth of engagement [mm]	10		
	Tightening torque [Nm]	72		
4	Fastening screw thread	M6		
	Maximum depth of engagement [mm]	14		
	Tightening torque [Nm]	10		

Item Designation		EGM B-Q		
		70-1x2	70-1x4	70-2x2
2	Centering pin thread	M10		
	Maximum depth of engagement [mm]	10		
	Tightening torque [Nm]	72		
4	Fastening screw thread	M8		
	Maximum depth of engagement [mm]	14		
	Tightening torque [Nm]	25		

Fastening to EGM B-L

Item Designation		EGM B-L	
		30-1x2	30-1x4
2	Centering pin thread	M10	
	Maximum depth of engagement [mm]	10	
	Tightening torque [Nm]	72	
4	Fastening screw thread	M6	
	Maximum depth of engagement [mm]	14	
	Tightening torque [Nm]	10	

6 Commissioning

- Observe all notes in this chapter when commissioning and making adjustments on the system side of the product.



⚠ DANGER

Danger from electric voltage!

Touching live parts may result in death.

- Switch off the power supply before any assembly, adjustment or maintenance work and secure against being switched on again.
- Only qualified electricians may perform electrical installations.
- Check if de-energized, ground it and hot-wire.
- Cover live parts.



⚠ DANGER

Risk of injury due to magnetic fields!

The integrated electric permanent magnets can pose a risk to people with an active or passive implant.

- People with pacemakers or active or passive implants are prohibited from entering the area of the magnetic field.



⚠ WARNING

Danger of crushing due to magnetically attracted tools!

Tools may be attracted by strong magnetic fields and cause severe injuries.

- Only work in deactivated and demagnetized state.



⚠ WARNING

Risk of burns through contact with hot surfaces!

Surfaces of components can heat up severely during operation. Skin contact with hot surfaces causes severe burns to the skin.

- For all work in the vicinity of hot surfaces, wear safety gloves.
- Before carrying out any work, make sure that all surfaces have cooled down to the ambient temperature.



⚠ WARNING

Risk of injury due to loss of workpiece!

A holding force that is too low can lead to the loss of a workpiece and serious injuries during handling.

- Test workpiece suitability for each type of workpiece separately.
- Increase the holding force if necessary.
- Observe the maximum permissible load capacity, ▶ 3 [16].
- Avoid overheating the product. If necessary, reduce the number of activations per minute.

6.1 General instructions on commissioning

The product is only to be operated in conjunction with a controller ECG:

CAUTION

Material damage due to incorrect operation!

The product is only to be operated in conjunction with a controller ECG.

- Observe the Assembly and Operating Manual for the controller ECG, in particular the following instructions:
 - ⇒ Signal sequences for activation/deactivation of product
 - ⇒ Setup of holding process with optional handheld device.

NOTE

During commissioning and operation, observe the following instructions:

- Always position the product on the physical center of gravity of the workpiece.
- Do not magnetize the product until the workpiece is fully covering the contact surface of the workpiece.
- Do not lift workpiece up until it has been successfully magnetized.
- Adapt the shifting speed so that no inherent motion of the workpiece occurs.

For workpieces with a round contact surface, use an optional pole extension or suitable stop.

6.2 Operation with controller ECG-C or ECG-W

- **Repeat the following steps each time the workpiece type is changed:**
 - Connecting plug is adapted, ▶ 5.2.2.2 [33].
 - Product and controller are ready for operation.
 - Product is demagnetized.
1. Position the product on the contact surface of the workpiece.
 2. Magnetize the product.
 3. Raise the workpiece somewhat and execute a brief test motion.
 - ⇒ If the workpiece is not held securely, reduce the speed and repeat the test.
 - ⇒ If required, use a pole extension or stop.
 4. Test the holding force for the full shifting motion:
 - ⇒ Raise and shift workpiece.
 - ⇒ If the workpiece is not held securely, reduce the speed and repeat the test.
 - ⇒ If required, use a pole extension or stop.
 5. Set the workpiece down at the destination
 6. Demagnetize the product and move it away from the workpiece.

The workpiece must remain secure at the depositing location.

NOTE

In case of different results, ▶ 7 [41]. In case of questions contact SCHUNK.

6.3 Operation with controller ECG-R

- **Repeat the following steps each time the workpiece type is changed:**
 - Connecting plug is adapted, ▶ 5.2.2.2 [433].
 - Product and controller are ready for operation.
 - Product is demagnetized.
- 1. Position the product on the contact surface of the workpiece.
- 2. Set the holding force level.
- 3. Magnetize the product.
- 4. Check/adapt the selected holding force level:
 - ⇒ Raise the workpiece somewhat and execute a brief test motion.
 - ⇒ If the workpiece is not held securely, increase the holding force level or reduce the speed and repeat the test.
 - ⇒ If required, use a pole extension or stop.
- 5. Test the holding force for the full shifting motion:
 - ⇒ Raise and shift workpiece.
 - ⇒ If the workpiece is not held securely, increase the holding force level or reduce the speed and repeat the test.
 - ⇒ If required, use a pole extension or stop.
- 6. Set the workpiece down at the destination
- 7. Demagnetize the product and move it away from the workpiece.
The workpiece must remain secure at the depositing location.

NOTE

In case of different results, ▶ 7 [441]. In case of questions contact SCHUNK.

7 Trouble shooting

NOTE

When consulting with SCHUNK, always specify the serial and ID numbers of the magnetic gripper.

7.1 Product remains inoperable even after the power supply is turned on

Possible cause	Corrective action
Cable connected incorrectly.	Check connection. Check control cabinet and ECG.
Fault circuit interrupter trips.	Check the product connection to ground connection.
Product and ECG are not compatible.	Check compatibility, max. permitted number of magnetic grippers and max. permitted cable length (20 m) to the magnetic gripper (see catalog datasheet EGM).

7.2 Workpiece is detached from the product

Possible cause	Corrective action
Product is not performing the magnetization process at all or not correctly.	Check the product, cables and connections for damage.
	Check the activation time and correct if necessary. Before activation, the magnetic surface must lie completely against the workpiece.
The holding force is not sufficient.	Check the magnetic surface and contact surface of the workpiece for air gaps and clean if necessary. If required, change the product positioning on the workpiece.
	Check that the workpiece complies with the technical data, ▶ 3 [□ 16].
	Check workpiece suitability, ▶ 4.4 [□ 26].
	If necessary, remove the pole extension or stop. Test the shift process again for safe holding.
	Only ECG-R: Select a higher holding force level and repeat the magnetization process.

7.3 Demagnetization was not performed correctly

Possible cause	Corrective action
Workpiece has excessive residual magnetism and does not detach properly.	Perform the demagnetization process once again. Check the lines and connections for errors and damage. Ensure that the voltage supply is correct.

8 Maintenance

8.1 Maintenance intervals

Maintenance interval	Maintenance work
Before each use	Clean the magnetic surface of the product.
Regularly	Clean the product and check for damage, especially for material accumulation. Replace the product if necessary.

8.2 Check and repair the product

CAUTION

Damage caused by faulty disassembly and assembly!

Incorrect disassembly and assembly can cause damage to the product and/or accessories.

- The product and/or accessories may only be checked and repaired by SCHUNK.

9 EU Declaration of Conformity

Manufacturer S.P.D. S.p.A.
Via Galileo Galilei 2/4
I-24043 Caravaggio (BG)

Product designation: Electric permanent magnetic gripper EGM
ID number 306350, 306351, 306352, 306360, 306361, 306362, 306370, 306372,
306371, 306380, 306382, 306381, 306373, 306374

We hereby declare that the product complies with all relevant harmonization legislation of the following directives at the time of declaration.

The declaration is rendered invalid if modifications are made to the product.

- **Electromagnetic compatibility (EMC directive) 2014/30/EU**
- **Low Voltage Directive 2014/35/EU**

Applied harmonized standards, especially:

EN ISO 12100:2010 Safety of machinery – General principles for design –
Risk assessment and risk reduction

EN 60204-1: 2006-09 + A1: 2009-02 Safety of machinery – Electrical equipment of machines

Signed for and on behalf of: S.P.D. S.p.A.

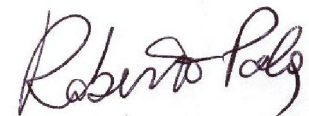

p.p. Roberto Pola;
Legal Representative

Caravaggio August 2023

10 UKCA declaration of Conformity

Manufacturer/
Distributor SCHUNK Intec Limited
 Clamping and gripping technology
 3 Drakes Mews, Crownhill
 MK8 0ER Milton Keynes

Product designation: Electric permanent magnetic gripper EGM

ID number 306350, 306351, 306352, 306360, 306361, 306362, 306370, 306372,
 306371, 306380, 306382, 306381, 306373, 306374

We hereby declare on our sole authority that the product meets the requirements of the following directives at the time of the declaration.

The declaration is rendered invalid if modifications are made to the product.

- **Electromagnetic Compatibility Regulations 2016**
- **Low Voltage Directive 2014/35/EU**

Applied harmonized standards, especially:

EN ISO 12100:2010 Safety of machinery – General principles for design –
 Risk assessment and risk reduction

EN 60204-1: 2006-09 + Safety of machinery – Elektrical equipment of machines
A1: 2009-02

Person authorized to compile the technical documentation:
Marcel Machado, address: refer to manufacturer's address

Signed for and on behalf of: SCHUNK SE & Co. KG

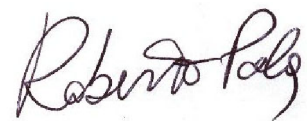

p.p. Roberto Pola;
Legal Representative

Caravaggio August 2023

11 Translation of the original declaration of incorporation

in terms of the Directive 2006/42/EG, Annex II, Part 1 Section B.

Manufacturer S.P.D. S.p.A.
Via Galileo Galilei 2/4
I-24043 Caravaggio (BG)

We hereby declare that the partly completed machine described below

Product designation: Electric permanent magnetic gripper / EGM /electric
ID number 306350, 306351, 306352, 306360, 306361, 306362, 306370, 306372,
306371, 306380, 306382, 306381, 306373, 306374

meets the following basic occupational health and safety of the Machinery Directive 2006/42/EC:

No. 1.1.1, No. 1.1.2, No. 1.1.3, No. 1.1.5, No. 1.3.2, No. 1.5.1, No. 1.5.2; No. 1.5.4, No. 1.5.6, No. 1.5.8, No. 1.5.10, No. 1.5.11, No. 1.5.13

The partly completed machinery may not be put into operation until it has been confirmed that the machine into which the partly completed machinery is to be installed complies with the provisions of the Machinery Directive (2006/42/EC). The declaration shall be rendered invalid if modifications are made to the product.

Applied harmonized standards, especially:

EN ISO 12100:2010 Safety of machinery – General principles for design –
Risk assessment and risk reduction

The special technical documentation according to Annex VII, Part B, belonging to the partly completed machine, has been created.

Person authorized to compile the technical documentation:
refer to manufacturer's address

Signed for and on behalf of: S.P.D. S.p.A.

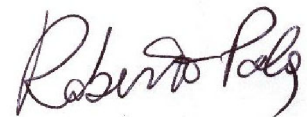

p.p. Roberto Pola;
Legal Representative

Caravaggio August 2023





SCHUNK SE & Co. KG
Toolholding and workholding | Gripping Technology |
Automation technology

Bahnhofstr. 106 - 134
D-74348 Lauffen/Neckar
Tel. +49-7133-103-0
Fax +49-7133-103-2399
info@de.schunk.com
schunk.com

Folgen Sie uns | *Follow us*



Wir drucken nachhaltig | *We print sustainable*