

# Assembly and Operating Manual

## RST-D

### Ring indexing table

Translation of Original Operating  
Manual

## Imprint

### Copyright:

This manual is protected by copyright. The author is SCHUNK SE & Co. KG.  
All rights reserved.

### Technical changes:

We reserve the right to make alterations for the purpose of technical improvement.

**Document number:** 389517

**Version:** 10.00 | 22/01/2026 | en

Dear Customer,

Thank you for trusting our products and our family-owned company, the leading technology supplier of robots and production machines.

Our team is always available to answer any questions on this product and other solutions. Ask us questions and challenge us. We will find a solution!

Best regards,

Your SCHUNK team

Customer Management

Tel. +49-7133-103-2500

Fax +49-7133-103-2239

cms@de.schunk.com



**Please read the operating manual in full and keep it close to the product.**

## Table of Contents

<b>1 General .....</b>	<b>5</b>
1.1 About this manual.....	5
1.1.1 Presentation of Warning Labels .....	5
1.1.2 Applicable documents .....	6
1.1.3 Sizes.....	6
1.2 Warranty .....	6
1.3 Scope of delivery.....	6
1.4 Accessories .....	6
<b>2 Basic safety notes .....</b>	<b>7</b>
2.1 Intended use.....	7
2.2 Not intended use .....	7
2.3 Constructional changes.....	7
2.4 Spare parts .....	7
2.5 Environmental and operating conditions.....	8
2.6 Personnel qualification .....	8
2.7 Personal protective equipment .....	9
2.8 Notes on safe operation.....	9
2.9 Transport.....	9
2.10 Malfunctions.....	10
2.11 Disposal .....	10
2.12 Fundamental dangers .....	10
2.12.1 Protection during handling and assembly .....	10
2.12.2 Protection during commissioning and operation .....	11
2.12.3 Protection against dangerous movements .....	11
2.12.4 Protection against electric shock.....	12
2.13 Notes on particular risks .....	13
<b>3 Technical data .....</b>	<b>14</b>
3.1 Type designation.....	14
3.2 Basic data .....	14
3.3 Fluid consumption .....	14
<b>4 Design and description .....</b>	<b>16</b>
4.1 Configuration .....	16
4.2 Description .....	16
<b>5 Assembly and settings .....</b>	<b>17</b>
5.1 Assembling and connecting.....	17

5.2	Connections .....	19
5.2.1	Mechanical connection .....	19
5.2.2	Air connection .....	21
5.3	Fitting the media feed-through (only for sizes 87 and 134) .....	22
5.4	Settings.....	23
5.4.1	Adjusting the end positions.....	23
5.4.2	Set swivel time .....	23
5.4.3	Setting the speed .....	23
5.4.4	Setting the shock absorber stroke .....	24
5.4.5	Setting the end position dampers .....	25
5.5	Mounting the sensor.....	28
5.5.1	Overview of sensors .....	28
5.5.2	Mounting inductive proximity switches IN 80, NI 30.....	29
5.5.3	Mounting MMS 22 magnetic switch .....	30
<b>6</b>	<b>Handling and operation.....</b>	<b>31</b>
6.1	Measures before operation .....	31
6.2	Actuation .....	32
6.2.1	Actuation of clockwise pulsing .....	32
6.2.2	Actuation of anti-clockwise pulsing .....	34
6.3	Calculating the total cycle time .....	36
<b>7</b>	<b>Troubleshooting.....</b>	<b>38</b>
7.1	Ring indexing table does not pulsing .....	38
7.2	Ring indexing table does not lock correctly .....	38
7.3	Signal for piston position or zero point cycle ring monitoring missing.....	38
7.4	Ring indexing table hitting in end positions .....	38
7.5	Useful load swings to end position.....	39
7.6	Cycle times are not reached .....	39
<b>8</b>	<b>Maintenance .....</b>	<b>40</b>
8.1	Maintenance interval .....	40
8.2	Inspect shock absorbers.....	40
8.3	Lubricants/Lubrication points (basic lubrication) .....	41
8.4	Wearing parts.....	42
8.5	Assembly drawing .....	43
<b>9</b>	<b>Translation of the original declaration of incorporation .....</b>	<b>44</b>
<b>10</b>	<b>UKCA declaration of incorporation .....</b>	<b>45</b>
<b>11</b>	<b>Information on the RoHS Directive, REACH Regulation and Substances of Very High Concern (SVHC) .....</b>	<b>46</b>

# 1 General

## 1.1 About this manual

This manual contains important information for a safe and appropriate use of the product.

This manual is an integral part of the product and must be kept accessible for the personnel at all times.

Before starting work, the personnel must have read and understood this operating manual. Prerequisite for safe working is the observance of all safety instructions in this manual.

In addition to these instructions, the documents listed under ▶ 1.1.2 [ 6 ] are applicable.

**NOTE:** The illustrations in this manual are intended to provide a basic understanding and may deviate from the actual version.

### 1.1.1 Presentation of Warning Labels

To make risks clear, the following signal words and symbols are used for safety notes.



#### **⚠ DANGER**

**Dangers for persons!**

Non-observance will inevitably cause irreversible injury or death.



#### **⚠ WARNING**

**Dangers for persons!**

Non-observance can lead to irreversible injury and even death.



#### **⚠ CAUTION**

**Dangers for persons!**

Non-observance can cause minor injuries.

#### **NOTICE**

**Material damage!**

Information about avoiding material damage.

### 1.1.2 Applicable documents

- General terms of business \*
- Catalog data sheet of the purchased product \*
- Assembly and operating manuals of the accessories \*

The documents labeled with an asterisk (\*) can be downloaded from [schunk.com/downloads](http://schunk.com/downloads).

### 1.1.3 Sizes

This operating manual applies to the following sizes:

- RST-D 60
- RST-D 87
- RST-D 134

## 1.2 Warranty

If the product is used as intended, the warranty is valid for 24 months from the ex-works delivery date under the following conditions:

- Observe the specified maintenance and lubrication intervals
- Observe the ambient conditions and operating conditions

Parts touching the workpiece and wear parts are not included in the warranty.

## 1.3 Scope of delivery

The scope of delivery includes

- Ring indexing table RST-D in the version ordered
- Safety information (product-specific instructions available online)
- Accessory pack

## 1.4 Accessories

A wide range of accessories are available for this product. For information regarding which accessory articles can be used with the corresponding product variants, see catalog data sheet.

### Sealing kit

Seal kit for	ID number
RST-D 60	1314393
RST-D 87	1314396
RST-D 134	1314397

## 2 Basic safety notes

### 2.1 Intended use

This product has been designed for reliable pivoting with specified cycle types of workpieces or other objects.

- The product may only be used within the scope of its technical data, ▶ 3 [14].
- When implementing and operating components in safety-related parts of the control systems, the basic safety principles in accordance with DIN EN ISO 13849-2 apply. The proven safety principles in accordance with DIN EN ISO 13849-2 also apply to categories 1, 2, 3 and 4.
- The product is intended for installation in a machine/ automated system. The applicable guidelines for the machine/ automated system must be observed and complied with.
- The product is intended for industrial and industry-oriented use.
- Appropriate use of the product includes compliance with all instructions in this manual.

### 2.2 Not intended use

Inappropriate use includes using the product as a cutting tool.

- Any utilization that exceeds or differs from the appropriate use is regarded as misuse.

### 2.3 Constructional changes

#### Implementation of structural changes

Modifications, changes or reworking, e.g. additional threads, holes, or safety devices, can damage the product or impair its functionality or safety.

- Structural changes should only be made with the written approval of SCHUNK.

### 2.4 Spare parts

#### Use of unauthorized spare parts

Using unauthorized spare parts can endanger personnel and damage the product or cause it to malfunction.

- Use only original spare parts or spares authorized by SCHUNK.

## 2.5 Environmental and operating conditions

### Required ambient conditions and operating conditions

Incorrect ambient and operating conditions can make the product unsafe, leading to the risk of serious injuries, considerable material damage and/or a significant reduction to the product's life span.

- Make sure that the product is used only in the context of its defined application parameters, ▶ 3 [14].
- Make sure that the product is not exposed to excessive vibrations and/or strokes.
- Ensure that no strong magnetic fields impair the function of the product.

Contact your SCHUNK partner if the product is to be used in strong magnetic fields.

## 2.6 Personnel qualification

### Inadequate qualifications of the personnel

If the personnel working with the product is not sufficiently qualified, the result may be serious injuries and significant property damage.

- All work may only be performed by qualified personnel.
- Before working with the product, the personnel must have read and understood the complete assembly and operating manual.
- Observe the national safety regulations and rules and general safety instructions.

The following personal qualifications are necessary for the various activities related to the product:

#### Trained electrician

Due to their technical training, knowledge and experience, trained electricians are able to work on electrical systems, recognize and avoid possible dangers and know the relevant standards and regulations.

#### Qualified personnel

Due to its technical training, knowledge and experience, qualified personnel is able to perform the delegated tasks, recognize and avoid possible dangers and knows the relevant standards and regulations.

#### Instructed person

Instructed persons were instructed by the operator about the delegated tasks and possible dangers due to improper behaviour.

#### Service personnel of the manufacturer

Due to its technical training, knowledge and experience, service personnel of the manufacturer is able to perform the delegated tasks and to recognize and avoid possible dangers.

## 2.7 Personal protective equipment

### Use of personal protective equipment

Personal protective equipment serves to protect staff against danger which may interfere with their health or safety at work.

- When working on and with the product, observe the occupational health and safety regulations and wear the required personal protective equipment.
- Observe the valid safety and accident prevention regulations.
- Wear protective gloves to guard against sharp edges and corners or rough surfaces.
- Wear heat-resistant protective gloves when handling hot surfaces.
- Wear protective gloves and safety goggles when handling hazardous substances.
- Wear close-fitting protective clothing and also wear long hair in a hairnet when dealing with moving components.

## 2.8 Notes on safe operation

### Incorrect handling of the personnel

Incorrect handling and assembly may impair the product's safety and cause serious injuries and considerable material damage.

- Avoid any manner of working that may interfere with the function and operational safety of the product.
- Use the product as intended.
- Observe the safety notes and assembly instructions.
- Do not expose the product to any corrosive media. This does not apply to products that are designed for special environments.
- Eliminate any malfunction immediately.
- Observe the care and maintenance instructions.
- Observe the current safety, accident prevention and environmental protection regulations regarding the product's application field.

## 2.9 Transport

### Handling during transport

Incorrect handling during transport may impair the product's safety and cause serious injuries and considerable material damage.

- When handling heavy weights, use lifting equipment to lift the product and transport it by appropriate means.

- Secure the product against falling during transportation and handling.
- Stand clear of suspended loads.

## 2.10 Malfunctions

### Behavior in case of malfunctions

- Immediately remove the product from operation and report the malfunction to the responsible departments/persons.
- Order appropriately trained personnel to rectify the malfunction.
- Do not recommission the product until the malfunction has been rectified.
- Test the product after a malfunction to establish whether it still functions properly and no increased risks have arisen.

## 2.11 Disposal

### Handling of disposal

The incorrect handling of disposal may impair the product's safety and cause serious injuries as well as considerable material and environmental harm.

- Follow local regulations on dispatching product components for recycling or proper disposal.

## 2.12 Fundamental dangers

### General

- Observe safety distances.
- Never deactivate safety devices.
- Before commissioning the product, take appropriate protective measures to secure the danger zone.
- Disconnect power sources before installation, modification, maintenance, or calibration. Ensure that no residual energy remains in the system.
- If the energy supply is connected, do not move any parts by hand.
- Do not reach into the open mechanism or movement area of the product during operation.

### 2.12.1 Protection during handling and assembly

#### Incorrect handling and assembly

Incorrect handling and assembly may impair the product's safety and cause serious injuries and considerable material damage.

- Have all work carried out by appropriately qualified personnel.
- For all work, secure the product against accidental operation.
- Observe the relevant accident prevention rules.
- Use suitable assembly and transport equipment and take precautions to prevent jamming and crushing.

#### **Incorrect lifting of loads**

Falling loads may cause serious injuries and even death.

- Stand clear of suspended loads and do not step into their swiveling range.
- Never move loads without supervision.
- Do not leave suspended loads unattended.

### **2.12.2 Protection during commissioning and operation**

#### **Falling or violently ejected components**

Falling and violently ejected components can cause serious injuries and even death.

- Take appropriate protective measures to secure the danger zone.
- Never step into the danger zone during operation.

### **2.12.3 Protection against dangerous movements**

#### **Unexpected movements**

Residual energy in the system may cause serious injuries while working with the product.

- Switch off the energy supply, ensure that no residual energy remains and secure against inadvertent reactivation.
- Never rely solely on the response of the monitoring function to avert danger. Until the installed monitors become effective, it must be assumed that the drive movement is faulty, with its action being dependent on the control unit and the current operating condition of the drive. Perform maintenance work, modifications, and attachments outside the danger zone defined by the movement range.
- To avoid accidents and/or material damage, human access to the movement range of the machine must be restricted. Limit/prevent accidental access for people in this area due through technical safety measures. The protective cover and protective fence must be rigid enough to withstand the maximum possible movement energy. EMERGENCY STOP switches must be easily and quickly accessible. Before starting up the machine

or automated system, check that the EMERGENCY STOP system is working. Prevent operation of the machine if this protective equipment does not function correctly.

#### **2.12.4 Protection against electric shock**

##### **Possible electrostatic energy**

Components or assembly groups may become electrostatically charged. When the electrostatic charge is touched, the discharge may trigger a shock reaction leading to injuries.

- The operator must ensure that all components and assembly groups are included in the local potential equalisation in accordance with the applicable regulations.
- While paying attention to the actual conditions of the working environment, the potential equalisation must be implemented by a specialist electrician according to the applicable regulations.
- The effectiveness of the potential equalisation must be verified by executing regular safety measurements.

## 2.13 Notes on particular risks



### **⚠ WARNING**

#### **Risk of injury from objects falling and being ejected!**

Falling and ejected objects during operation can lead to serious injury or death.

- Take appropriate protective measures to secure the danger zone.



### **⚠ WARNING**

#### **Risk of injury from rotating components!**

In the case of swivel units or rotary tables with a rotary drive, serious injuries can be caused by rotating components.

- Take appropriate protective measures to secure the danger zone.

### 3 Technical data

#### 3.1 Type designation

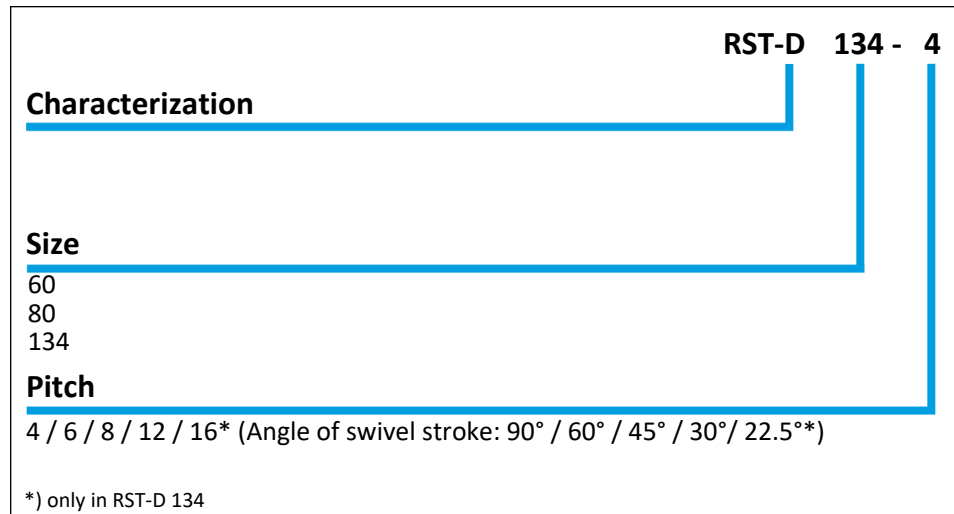

Type designation

#### 3.2 Basic data

Size	RST-D 60	RST-D 87	RST-D 134
Ambient temperature [°C]			
Min.		+ 5	
Max.		+ 60	
IP rating *		50	
Noise emission [dB(A)]		≤ 70	
Pressure medium	Compressed air, compressed air quality according to ISO 8573-1:2010 [7:4:4]		
Nominal working pressure [bar]		6	
Min. pressure [bar]		4	
Max. pressure [bar]		8	

#### NOTE

For the permissible cycle and swiveling times, see catalog data sheet.

More technical data is included in the catalog data sheet. Whichever is the latest version.

#### 3.3 Fluid consumption

Pitches	4	6	8	12	16
RST-D 60	21	14	11	7.5	-
Fluid consumption per cycle [cm <sup>3</sup> ]					

Pitches	4	6	8	12	16
RST-D 87 Fluid consumption per cycle [cm <sup>3</sup> ]	53	36	27.5	19	-
RST-D 134 Fluid consumption per cycle [cm <sup>3</sup> ]	198	135	103	71	55

Tab.: Operating data for compressed air connection

### NOTICE

#### Material damage if oil-free compressed air is used incorrectly!

The product may be damaged if the factory-applied lubrication is washed off.

- Operating with oil-free compressed air is not permitted if the product was already used with oiled compressed air.

## 4 Design and description

### 4.1 Configuration

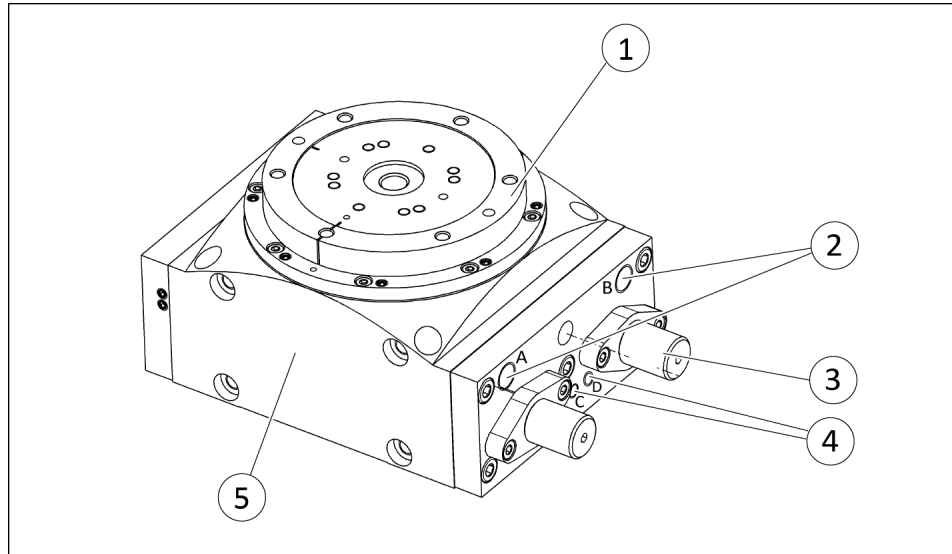

Ring indexing table RST-D

1	Drive ring
2	Main compressed air connections
3	Shock absorber
4	Compressed air connections for unlocking/locking
5	Housing

### 4.2 Description

Ring indexing unit for endless turning with a rotation angle up to 90° per cycle

Area of application: For fast movement cycles

## 5 Assembly and settings

### 5.1 Assembling and connecting



#### **⚠ WARNING**

##### **Risk of injury due to unexpected movements!**

If the power supply is switched on or residual energy remains in the system, components can move unexpectedly and cause serious injuries.

- Before starting any work on the product: Switch off the power supply and secure against restarting.
- Make sure, that no residual energy remains in the system.



#### **⚠ WARNING**

##### **Risk of injury from the product falling during assembly and operation!**

- Make sure that the product is securely mounted on the machine/system

#### **NOTICE**

##### **Material damage due to improper assembly!**

- When mounting loads, do not allow impermissible forces and moments to be exerted (see catalog data sheet).
- Select a suitable tightening torque when assembling the product or loads on the product in accordance with the generally accepted guidelines for screw connections.
- Secure all screws using a suitable chemical screw lock.

#### **NOTICE**

##### **Damage to the rotary module possible!**

The rotary module can be damaged if it arrives too abruptly in the end position.

- The rotary motion must reach the end position without jerk or bounce.
- Therefore flow control valves and shock absorbers must be used, ▶ 5.4.3 [ 23] and ▶ 5.4.4 [ 24].
- Please observe the information in the catalog pages.

---

**NOTE**

Observe the requirements for the compressed air supply, ▶ 3 [📄 14].

---

**Overview**

1. Check the evenness of the mounting surface, ▶ 5.2.1 [📄 19].
2. Screw the product to the machine/system, ▶ 5.2.1 [📄 19].
  - ⇒ Observe the maximal tightening torque, admissible screw-in depth and, if necessary, strength class.
3. Screw attachment onto the drive ring, ▶ 5.2.1 [📄 19].
4. Pneumatically connect product, ▶ 5.2.2 [📄 21].
5. Set swivel time, ▶ 5.4.2 [📄 23].
6. Adjust swiveling speed, ▶ 5.4.3 [📄 23].
7. Set the end position dampers, ▶ 5.4.5 [📄 25].
8. Connect the sensor, see assembly and operating manual of the sensor.
9. Mount the sensor, ▶ 5.5 [📄 28].
10. Execute test run, ▶ 6.2 [📄 32].
11. Correct settings, if necessary.

## 5.2 Connections

### 5.2.1 Mechanical connection

#### Evenness of the mounting surface

The values apply to the whole mounting surface to which the product is mounted.

Edge length	Permissible unevenness
< 100	< 0.02
> 100	< 0.05

Tab.: Requirements for evenness of the mounting surface (Dimensions in mm)

#### Connections at the drive ring

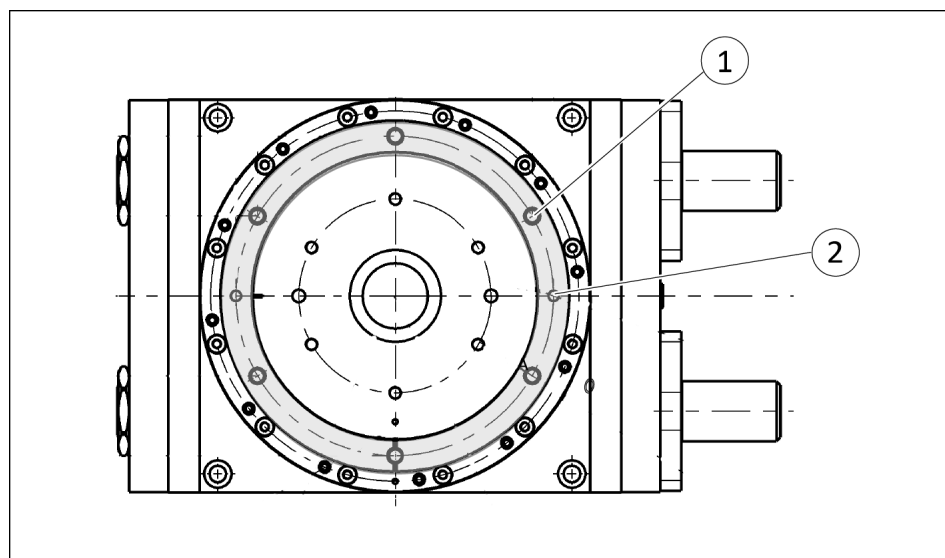

Fastening option at the attachment

Item	Mounting	RST-D		
		60	87	134
1	Thread for fastening screws (4x)	M4	M5	M6
	Max. depth of engagement from locating surface [mm]	7	9	12
2	Fit for centering pins [mm] (2x)	∅ 3 / 6	∅ 4 / 7	∅ 4 / 8
		deep	deep	deep

#### Connections at the housing

The product can be fastened in the following ways:

- Onto the base with screws from below (side A)
- Onto the base with screws from above (side B)
- Onto the rear side (side C, only with RST-D 60, 87)

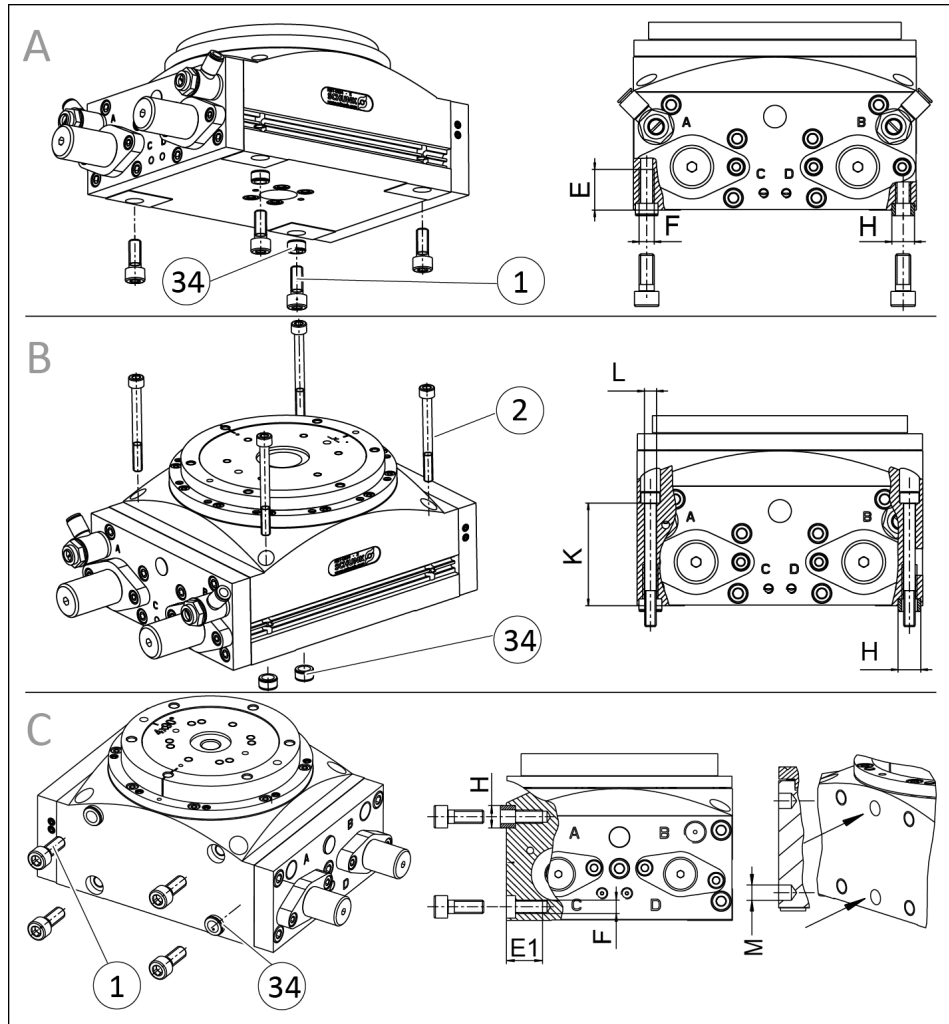

Connections at the housing

Item	Mounting	RST-D		
		60	87	134
1	Mounting screw according to standard DIN EN ISO 4762 (4x)	M5	M6	M8
2	Mounting screw according to standard DIN EN ISO 4762 (4x)	M4	M5	M6
34*	Centering sleeve [mm] (2x)	∅7 (ZH 700)	∅10 (ZH 10)	∅12 (ZH 12)
	E [mm]	11.5	16	18
	E1 [mm]	8.5	12	-
	F	M5	M6	M8
	G [mm]	1.0	2.7	3.0
	H [mm]	∅7	∅10	∅12
	K [mm]	31.0	40.0	54.0
	L [mm]	∅5.3	∅6.4	∅8.4
	M [mm]	∅5 / 2.5 deep	-	-

\* Contained in accessory pack.

## 5.2.2 Air connection

### NOTE

Observe the requirements for the compressed air supply, ▶ 3 [14].

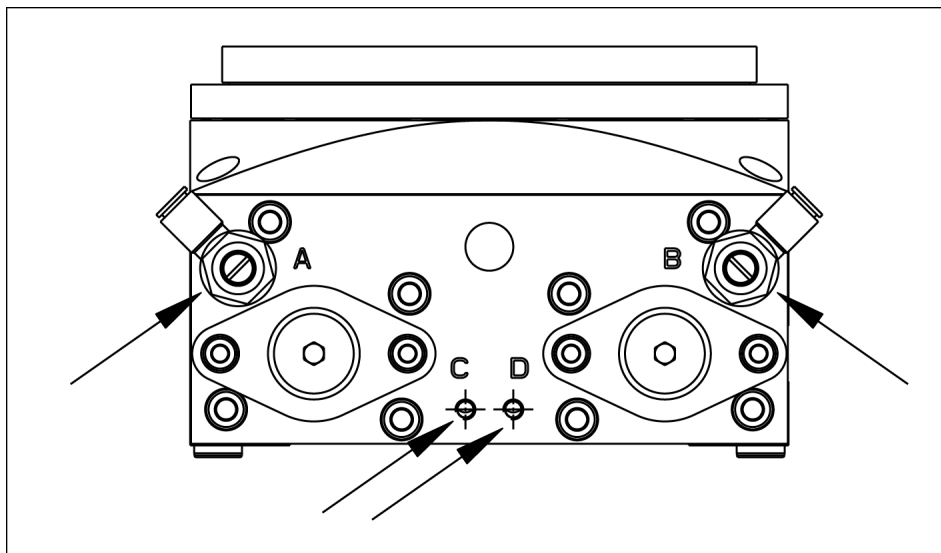

Pneumatic connection RST-D 134

Item	Description	RST-D		
		60	87	134
A	Actuation of drive pistons Pivoting clockwise ( <b>CW</b> ) Note: Mount exhaust throttle	M5	G 1/8"	G 1/4"
B	Actuation of drive pistons Pivoting anti-clockwise ( <b>ACW</b> ) Note: Mount exhaust throttle	M5	G 1/8"	G 1/4"
C	Actuation of the locking mechanism Position <b>unlock</b> *	M3	M5	M5
D	Actuation of the locking mechanism Position <b>lock</b> *	M3	M5	M5

Tab.: Pneumatic actuation / Thread diameter of the air connections

\* not included in the scope of delivery

The catalog data sheet contains more information.

### 5.3 Fitting the media feed-through (only for sizes 87 and 134)

1. Fasten feed-through (3) and flange (4) to the base unit (5) using the screws (2) and dowel pins (1).
2. Screw the distributor (6) to the opposite side using the screws (7).

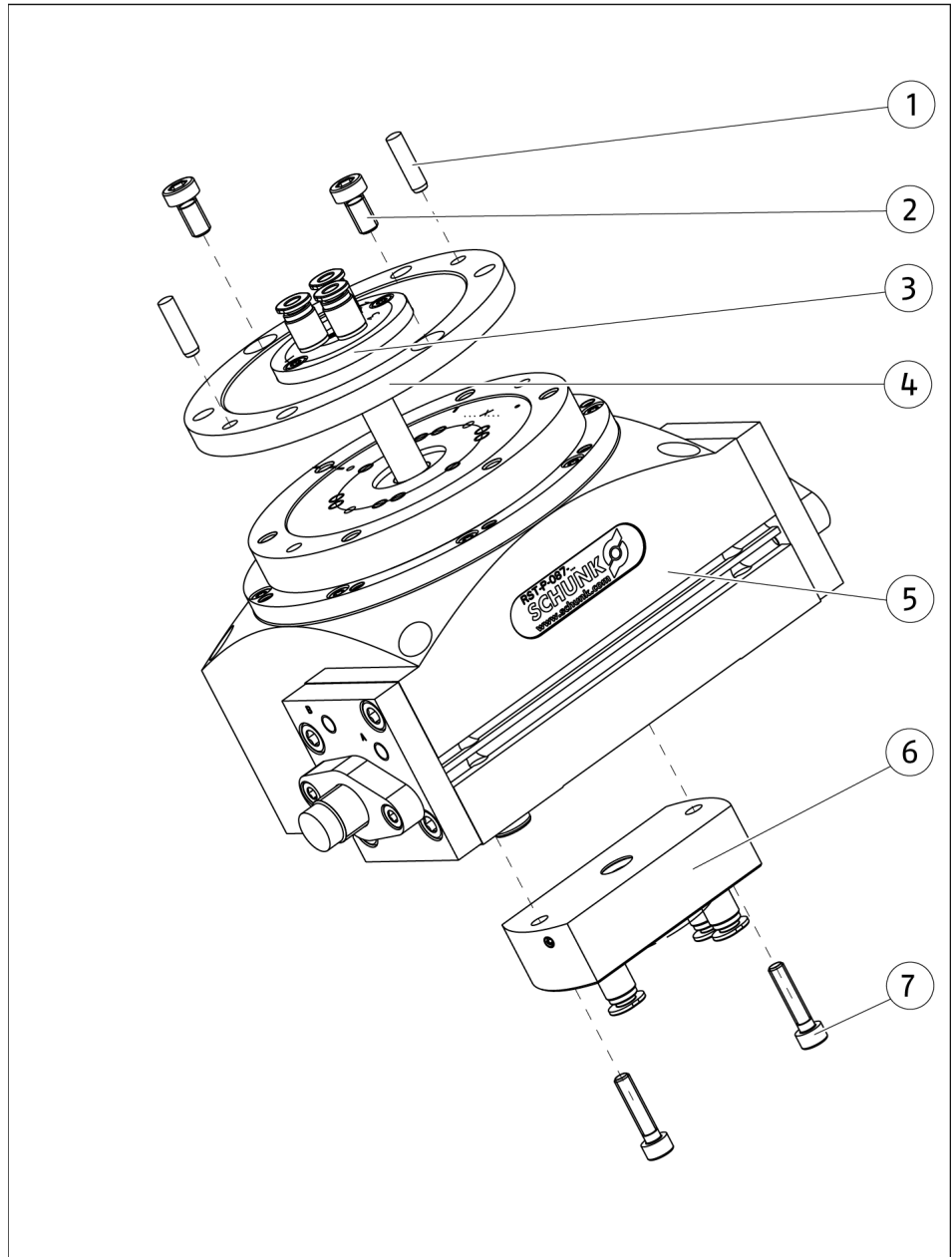

Fitting the media feed-through

## 5.4 Settings

### 5.4.1 Adjusting the end positions

The positions for the end positions are set by SCHUNK and must not be changed.

### 5.4.2 Set swivel time

The catalog data sheet contains data for the swiveling time. The swiveling time is set with the exhaust air throttle valves. These can be found in the accessory pack.

#### NOTE

The desired swiveling time is usually only achievable through a combination of setting the exhaust air throttle valves and the end position dampers.

### 5.4.3 Setting the speed

#### NOTICE

#### Material damage due to erroneous settings!

If the end position is approached too hard, the product may be damaged.

- Adjust exhaust throttle valve and shock absorber so that the movement is braked smoothly.

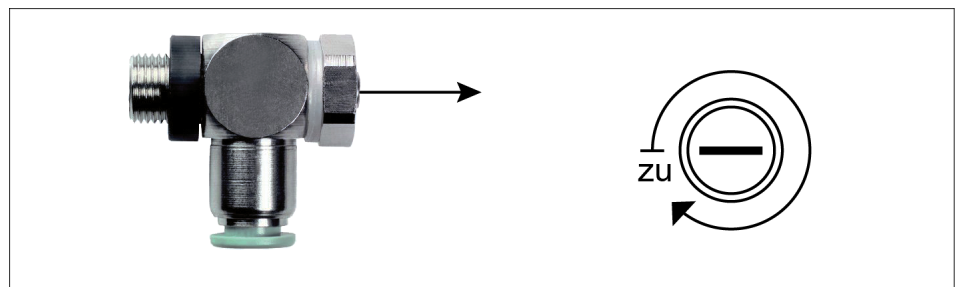

1. Close exhaust throttle valve completely.

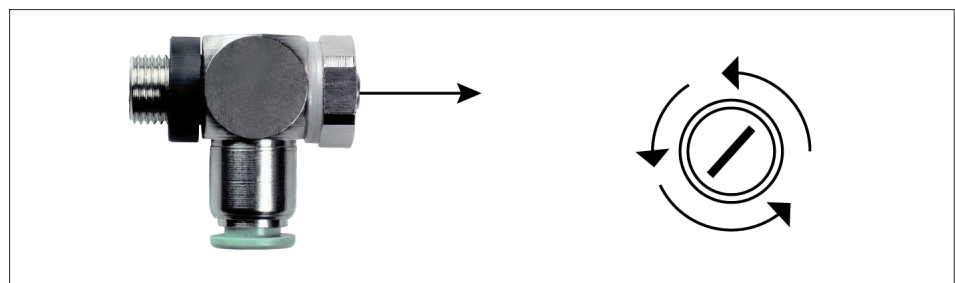

2. Open exhaust throttle valve until the product starts to move.
3. Continue to open the exhaust throttle valve incrementally until the movement decelerates smoothly.

- ⇒ If the speed is too low, the product will brake too soon and the end position will be reached too slowly.
- ⇒ If the speed is too high, the product will impact against the end position and the shock absorber will be overloaded.

---

**NOTE**

A smooth motion may also be too slow in many use-cases. Further settings can be made via the shock absorbers, ▶ 5.4.4 [ 24].

---

### 5.4.4 Setting the shock absorber stroke

---

**NOTE**

When received from the factory, the unit is set to utilize the maximum shock absorber stroke.

---

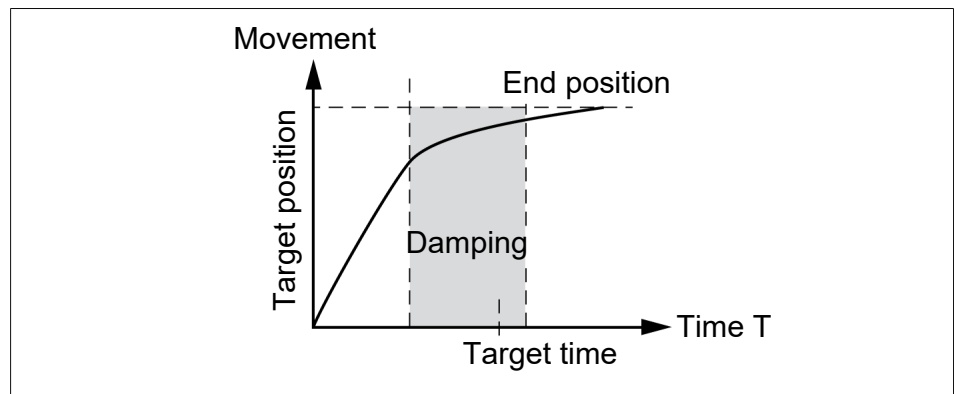

The shock absorber stroke is too long and the end position is reached too slowly.

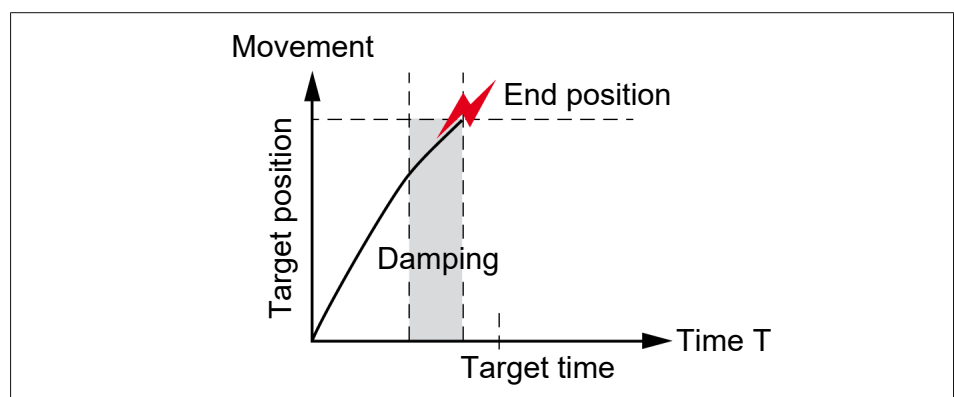

The shock absorber stroke is too short and the unit arrives in the end position too abruptly.

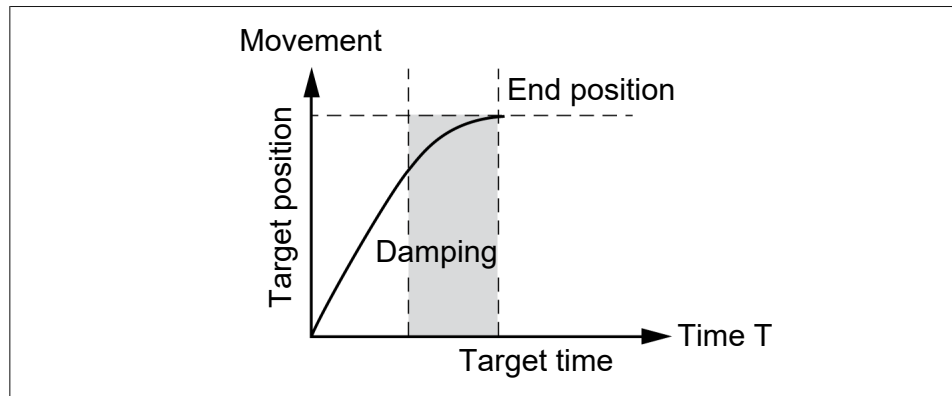

Optimal shock absorber stroke.

### 5.4.5 Setting the end position dampers

The dampers are factory-set so that the product can be operated safely with the maximum permissible load.

With smaller loads, an adjustment may be necessary to achieve the optimal cycle times through withdrawing the dampers.

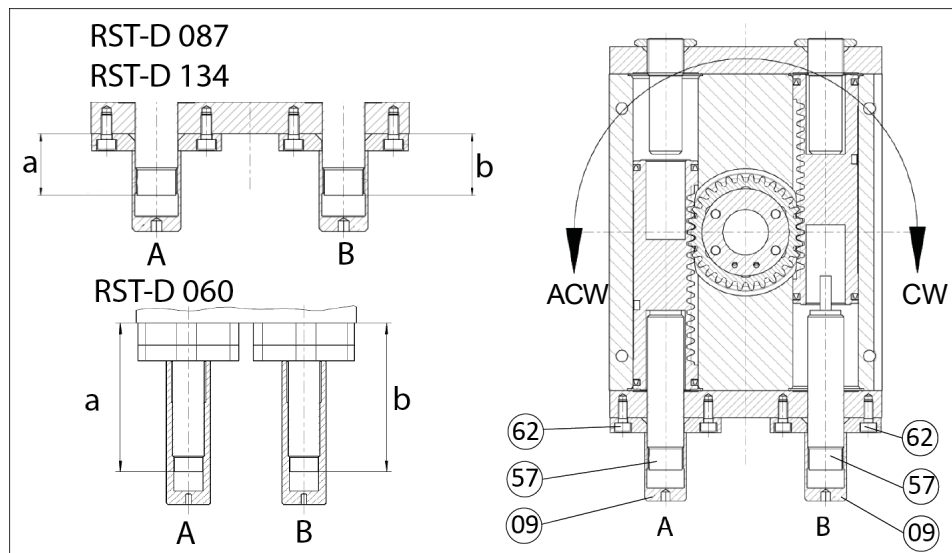

Setting the end position dampers

#### NOTE

**Dampers (57) do not serve as an end stop for the drive, but only for dampening.**

The drive piston must reach the intended stops, otherwise the module cannot lock correctly and continue pulsing.

- Always set the dampers (57) back so that the product performs the full angle stroke and allows pulsing to continue. The angle stroke and the cycling are engraved onto the middle section.

The dampers need to be set for the respective load-swivel direction.

Swivel direction	Dampers
Anti-clockwise (ACW)	A
Clockwise (CW)	B

**Load swivels in the clockwise / anti-clockwise direction**

- The load occurring during operation is mounted onto the product.
- 1. Unscrew counter sleeve (09).
- 2. Undo the screws (62) until the damper can be turned slightly.
  - ⇒ If the screws (62) have come loose, compressed air can escape to a small extent.
- 3. Adjust the dampers (57) to the swivel load by rotating back in the area "a min." to "a max." or "b min." to "b max.". For permitted adjustment dimensions, see following tables.
- 4. Tighten screws (62).
- 5. Test dampening during operation, correct swiveling time if necessary, and readjust the setting of the dampers.
- 6. Tighten counter sleeve (09) as far as it will go.
  - ⇒ The damper is set correctly if the device reaches its end position swiftly and without any mechanical impact.
- 7. Check whether the sequence and mechanical locking and unlocking function without any problems. If necessary, correct the setting.
- 8. **NOTICE! The counter sleeve (09) is used for locking the damper in place securely.** Make sure that the counter sleeve (09) is mounted on both sides and is tightened as far as it will go.

**Setting return stroke**

- If the load is only ever swiveled in one direction, the corresponding second absorber must be reset to dimension "a max." or "b max." to achieve fast cycle times (return stroke).
- The damper is set in load-swivel direction.
  - 1. Unscrew counter sleeve (09).
    - ⇒ The damper is set correctly if the product reaches its end position swiftly and without any mechanical impact.
  - 2. Undo the screws (62) until the damper can be turned slightly.
    - ⇒ If the screws (62) have come loose, compressed air can escape to a small extent.
  - 3. Rotate the dampers (57) back to "a max." or "b max." (see following tables).
  - 4. Tighten screws (62).
  - 5. Tighten counter sleeve (09) as far as it will go.
  - 6. Completely open connection throttle.

Permitted damper adjustment dimensions	RST-D 87	RST-D 134
Dimension "a min." or "b min." [mm] (maximum damper stroke)	17	29.5
Dimension "a max." or "b max." [mm] (minimum damper stroke) *	21.5	39
Dimension "a" or "b" [mm] factory settings	17.5	32

**NOTE**

When RST-D 60, the values for "a" and "b" vary depending on the pitch.

Permitted damper adjustment dimensions	RST-D 60			
	Pitch 4	Pitch 6	Pitch 8	Pitch 12
Dimension "b min." [mm] (maximum damper stroke)	47.5	41	38	34.5
Dimension "b max." [mm] (minimum damper stroke) *	53	46.5	43.5	40
Dimension "b" [mm] factory settings	50	43.5	40.5	37
Dimension "a min." [mm] (maximum damper stroke)	47.5			
Dimension "a max." [mm] (minimum damper stroke) *	53			
Dimension "a" [mm] factory settings	50			

**\*) The "minimum absorber stroke" is only designed for dampening the return stroke of the pistons.** If loads are moved, the appropriate damper may need to be reset.

## 5.5 Mounting the sensor

### NOTE

Observe the assembly and operating manual of the sensor for mounting and connecting.

The product is prepared for the use of sensors.

- For the exact type designations of suitable sensors, please see catalog datasheet and ▶ 5.5.1 [📄 28].
- For technical data for the suitable sensors, see assembly and operating manual and catalog datasheet.
  - The assembly and operating manual and catalog datasheet are included in the scope of delivery for the sensors and are available at [schunk.com](https://www.schunk.com).
- Information on handling sensors is available at [schunk.com](https://www.schunk.com) or from SCHUNK contact persons.

### 5.5.1 Overview of sensors

Designation	RST-D		
	60	87	134
Inductive proximity switch IN 80	X	X	
Inductive proximity switch NI 30			X
Magnetic switch MMS 22	X	X	X

## 5.5.2 Mounting inductive proximity switches IN 80, NI 30

### NOTICE

#### Material damage due to improper assembly!

The sensor may be destroyed if turned in too far.

- Observe the mounting sequence.

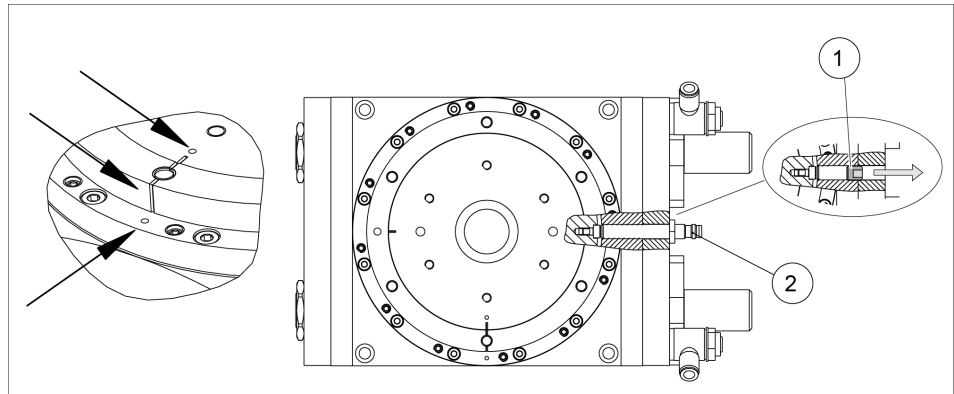

*Inductive proximity switch for monitoring the zero point position*

- 1.** Set cycle ring to zero point position:  
Marking groove on the cycle ring is in agreement with the marking holes in the switching plate and bearing ring (see arrows).
- 2.** Remove the locking screw (1).
- 3.** Screw sensor (2) into the thread until the signal is present at the output.
- 4.** Lock sensor into place with a counter-nut.

### 5.5.3 Mounting MMS 22 magnetic switch

#### NOTICE

#### Material damage due to an incorrect tightening torque!

If the threaded pin is tightened with an incorrect tightening torque, the product may be damaged.

- Observe a maximum tightening torque of 10 Ncm for the set-screws.

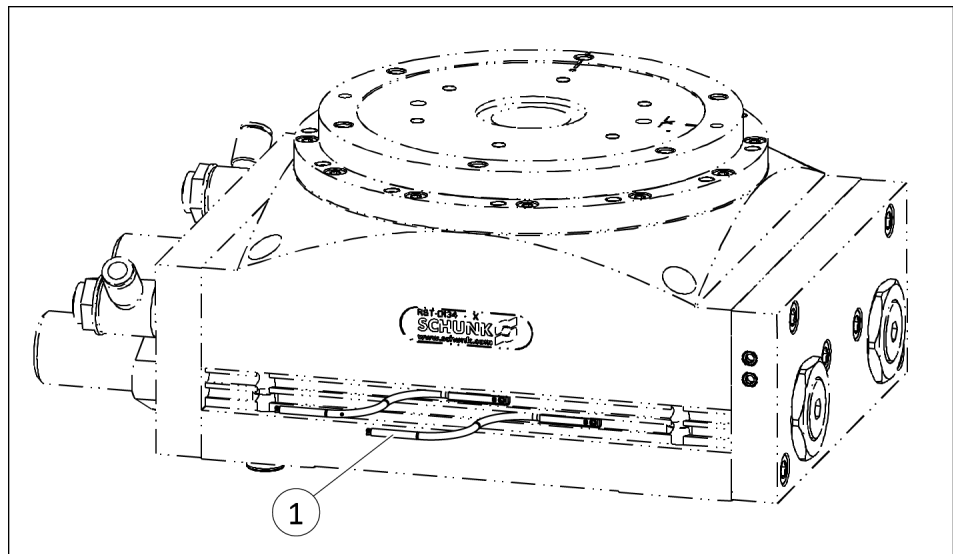

Sensor MMS for monitoring the end positions

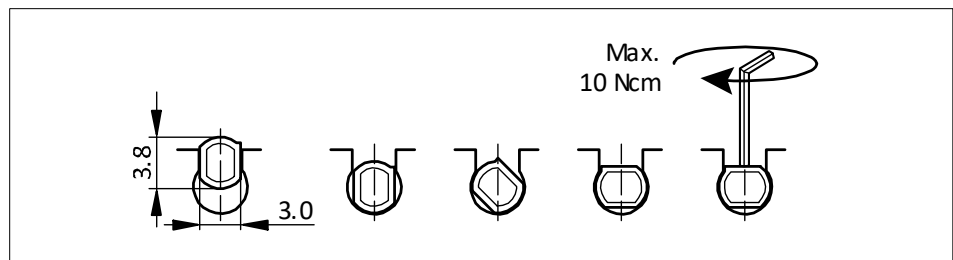

For monitoring the two end positions of the piston, one sensor each is installed.

1. Turn sensor (1) into the groove (1 - 4).
2. Pressurize piston with air pressure at connection "A" or "B" to ensure that it is in the end position ▶ 5.2.2 [ 21].
3. Set sensor (1) to piston position and tighten with set-screw.
4. If need be, repeat the procedure with the second sensor and the opposing piston position.
5. Bring product into the end positions and test the function.

## 6 Handling and operation

### 6.1 Measures before operation

- Check the technical specifications, ▶ 3 [📄 14].
- Do not use the product until trouble-free operation has been checked taking all permissible operating parameters into account.
- The swiveling time and the return stroke are regulated via throttle check valves, ▶ 5.2.2 [📄 21].

The speed is always set so that it starts at a low speed, and increases to a higher speed until the desired operating speed is reached.

## 6.2 Actuation

### 6.2.1 Actuation of clockwise pulsing

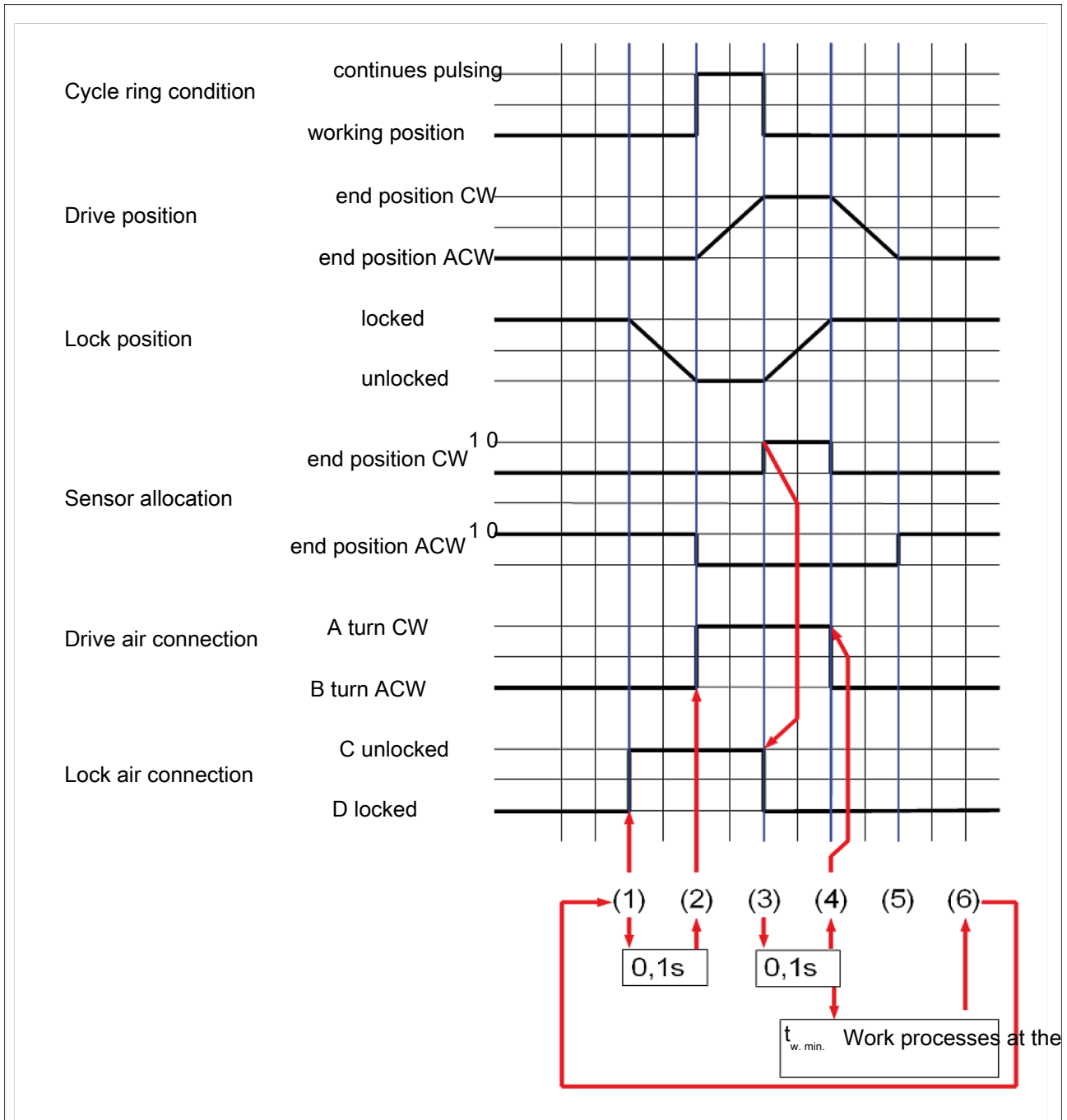

**CW:** Clockwise

**ACW:** Anti-clockwise

**tw.min.:** See chapter "Calculating the total cycle time" ▶ 6.3 [ 36]

## Description of clockwise pulsing

- RST-P in home position for operation of clockwise pulsing
  - Cycle ring in operating position and locked
  - Pressurized connection: D
  - Drive piston in end position ACW
  - Pressurized connection: B
  - Sensor assignment: End position ACW
  
- 1. RST-D in home position  
 Actuation of connection D → C (locked → unlocked)  
*Lock bolts release the cycle ring*  
**Up to step 2: Waiting time at least 0.1s**
- 2. Locking mechanism fully released  
 Actuation of connection B → A (turn ACW → turn CW)  
*Cycle ring is turned by predefined pitch*
- 3. Sensor reaches end position CW  
 Actuation of connection C → D (unlocked → locked)  
*Lock bolts lock the cycle ring*  
**Up to step 4: Waiting time at least 0.1s**
- 4. Cycle ring is locked  
 Actuation of connection A → B (turn CW → turn ACW)  
*Drive piston is decoupled and is moved back*  
**As of sensor leaving end position CW (falling edge), operations can be performed on the rotary table before new pulsing starts.**
- 5. Sensor reaches end position ACW  
*Drive piston is in end position ACW, home position is reached.*
- 6. Introduction of new pulsing

### 6.2.2 Actuation of anti-clockwise pulsing

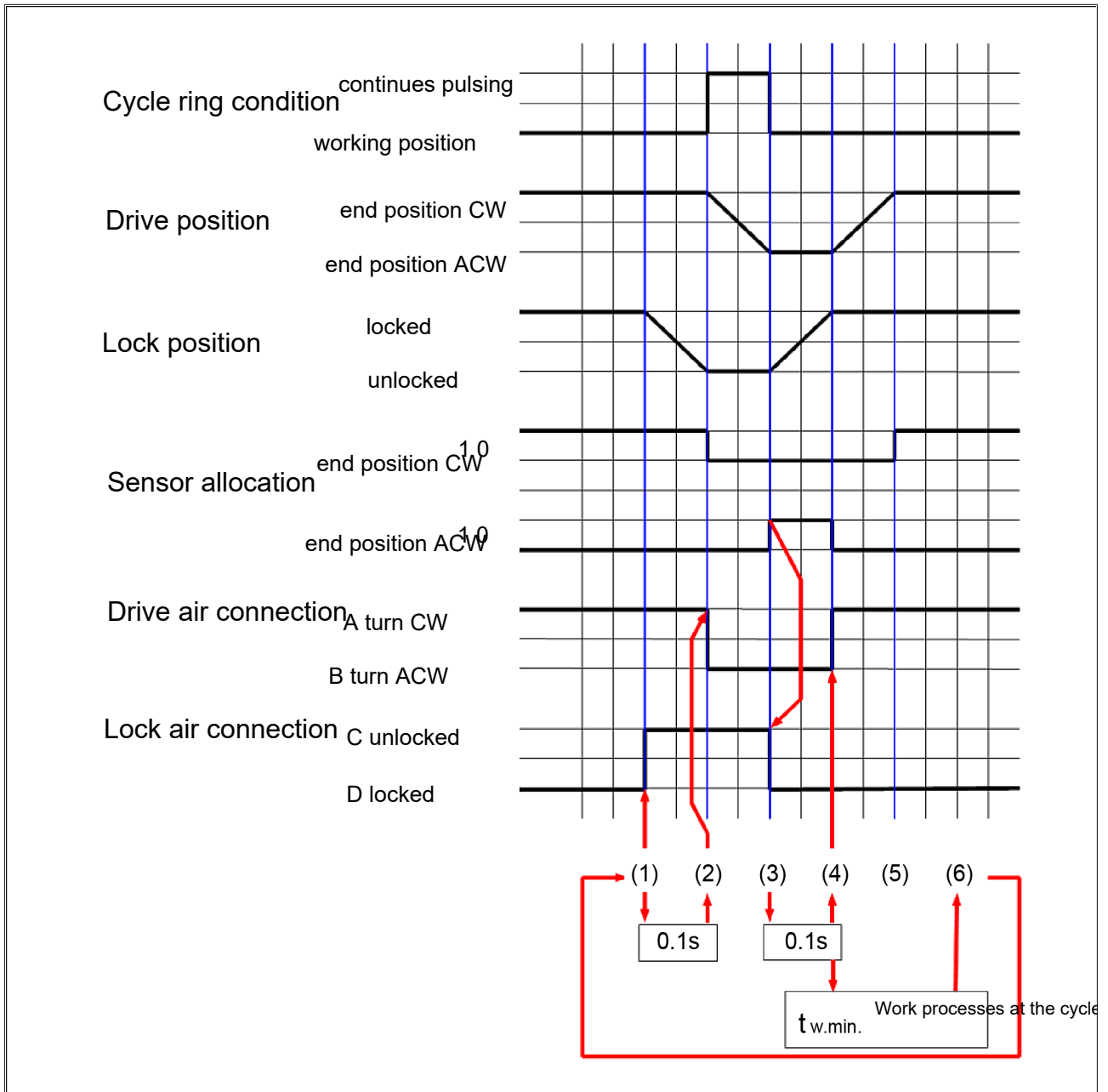

**CW:** Clockwise

**ACW:** Anti-clockwise

**tw.min.:** See chapter "Calculating the total cycle time" ▶ 6.3 [ 36]

#### Description of anti-clockwise pulsing

- RST-D in home position for operation of anti-clockwise pulsing
  - Cycle ring in operating position and locked
  - Pressurized connection: D
  - Drive piston in end position CW

- Pressurized connection: A
  - Sensor assignment: End position CW
1. RST-D in home position  
Actuation of connection D -> C (locked -> unlocked)  
*Lock bolts release the cycle ring*  
**Up to step 2: Waiting time at least 0.1s**
  2. Locking mechanism fully released  
Actuation of connection A -> B (turn CW -> turn ACW)  
*Cycle ring is turned by predefined pitch*
  3. Sensor reaches end position ACW  
Actuation of connection C -> D (unlocked -> locked)  
*Lock bolts lock the cycle ring*  
**Up to step 4: Waiting time at least 0.1s**
  4. Cycle ring is locked, connection B is pressurized  
Actuation of connection B -> A (turn ACW -> turn CW)  
*Drive piston is decoupled and is moved back*  
**As of sensor leaving end position ACW (falling edge) operations can be performed on the rotary table before new pulsing starts.**
  5. Sensor reaches end position CW  
*Drive piston is in end position CW, home position is reached.*
  6. Introduction of new pulsing

### 6.3 Calculating the total cycle time

The minimum possible time for the total sequence cycle ▶ 6.2 [ 32] is calculated as follows:

$$T_{\text{tot}} = t_{\text{swivel}} + 2 \times t_{\text{locking}} + t_{\text{w.min.}} + t_{\text{compensation}}$$

$t_{\text{w.min.}}$  is required as the return stroke time for the drive piston.

$t_{\text{compensation}}$  is based on reaction times of valves and the inertia of the moving mass.

#### NOTICE

#### Observe permissible number of cycles / min.

When operating the module using the parameters calculated as above, the maximum permissible number of cycles has to be taken into account.

	RST-D 060	RST-D 087	RST-D 134
$t_{\text{locking}}$ [s]		0.1	
$t_{\text{swiveling time}}$ [s]	See catalog data		
$t_{\text{w.min.}}$ [s]	0.1	0.1	0.2
	Value is higher for operations on the cycle ring		
$t_{\text{compensation}}$ [s]	See diagram		
Permissible number of cycles	See catalog data		

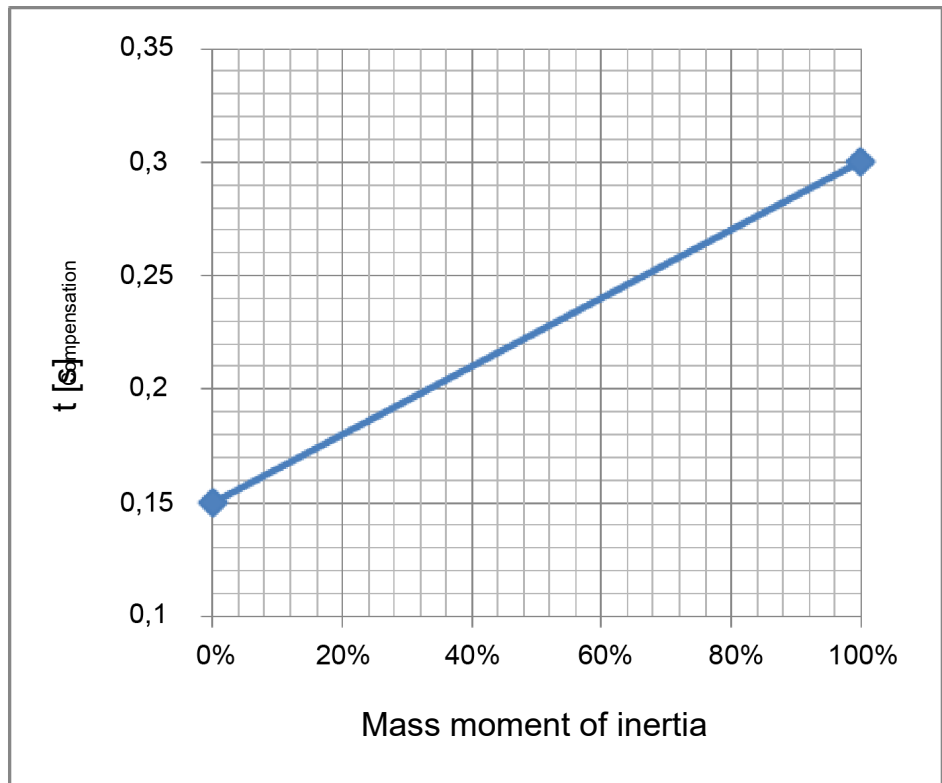

## 7 Troubleshooting

### 7.1 Ring indexing table does not pulsing

Possible cause	Corrective action
Pressure drops below minimum.	Check air supply. ▶ 5.2.2 [ 21]
Pressure lines connected incorrectly.	Check compressed air lines. ▶ 5.2.2 [ 21]
Component part defective.	Replace component or send it to SCHUNK for repair.
Product does not lock correctly	▶ 7.2 [ 38]

### 7.2 Ring indexing table does not lock correctly

Possible cause	Corrective action
Damper turned in too far (piston does not reach end position).	Readjust absorbers. ▶ 5.4.5 [ 25]
Pressure drops below minimum.	Check air supply. ▶ 5.2.2 [ 21]

### 7.3 Signal for piston position or zero point cycle ring monitoring missing

Possible cause	Corrective action
Zero point monitoring sensor set incorrectly.	Adjust sensor or if necessary change sensor. ▶ 5.5 [ 28]
Piston position monitoring sensor set incorrectly.	Adjust sensor or if necessary change sensor. ▶ 5.5 [ 28]
Proximity switch defective or set incorrect.	Change sensor. ▶ 5.5 [ 28]
Cable breakage.	Replace connection cable for sensor.

### 7.4 Ring indexing table hitting in end positions

Possible cause	Corrective action
Damping wrong adjustet.	Readjust absorbers. ▶ 5.4.5 [ 25] Readjust back stop. ▶ 5.4.5 [ 25]
Shock absorber defective.	Change the shock absorber. ▶ 5.4.5 [ 25]
Exhaust throttle defective.	Replacing the exhaust air throttle.

Possible cause	Corrective action
Swiveling speed too high.	Check swiveling time and adjust with exhaust air throttles as necessary. ▶ 5.2.2 [ 21]

## 7.5 Useful load swings to end position

Possible cause	Corrective action
Swiveling speed too high.	Check swiveling time and adjust with exhaust air throttles as necessary. ▶ 5.2.2 [ 21]
Shock absorber not well adjusted	Readjust absorbers. ▶ 5.4.5 [ 25]
Unfavorable installation.	Check construction.
RST-Dtype is undersized	Use RST-Dtype

## 7.6 Cycle times are not reached

Possible cause	Corrective action
ACTUAL operating pressure does not equal the TARGET rated operating pressure	Check operating pressure. ▶ 3 [ 14]
Compressed air lines are not installed optimally.	Check compressed air lines. Use exhaust air throttles from the accessory pack Inner diameters of compressed air lines are of sufficient size in relation to compressed air consumption. Keep compressed air lines between the product and directional control valve as short as possible. Flow rate of valve is sufficiently large relative to the compressed air consumption.
Dampening and return stroke not completely reset (not for swiveling load in both directions).	Readjust absorbers. ▶ 5.4.5 [ 25]
Damping wrong adjustet.	Readjust absorbers. ▶ 5.4.5 [ 25]
Swiveling speed not ideally set	Adjust swiveling speed. ▶ 5.4.2 [ 23] Caution: Observe setpoint times.

## 8 Maintenance

### 8.1 Maintenance interval

Interval [million cycles] for RST-D 60 / 87 / 134	Maintenance work
daily	Visually inspect the function of the shock absorbers, ▶ 8.2 [ 40]
2	Clean all parts thoroughly, check for damage and wear, if necessary replace seals and wearing parts, ▶ 8.4 [ 42].
2	Replace shock absorber, ▶ 5.4.5 [ 25]

### 8.2 Inspect shock absorbers

The shock absorbers have a limited lifespan, depending on the load.

Overloading of the product or exceeding the permitted swivel speed can lead to drastic reduction of the service life.

1. Regularly check that the shock absorbers are working.  
The shock absorber is working correctly if the product moves softly into the end positions when set correctly and the prescribed swiveling time is reached.
2. Observe the catalog data sheet and technical data, ▶ 3 [ 14].

### 8.3 Lubricants/Lubrication points (basic lubrication)

The product has life-time lubrication. The accessible seals need to be lubricated.

SCHUNK recommends the lubricants listed.

Greasing area	Lubricant
Seals and sealing surfaces	SCHUNK grease 1
Metallic sliding surfaces	SCHUNK grease 3
Rolling bearing	SCHUNK grease 10

Details regarding SCHUNK lubricant designations are available at [schunk.com/lubricants](https://www.schunk.com/lubricants).

The product contains food-compliant lubricants as standard. Components such as rolling bearings, linear guides, or shock absorbers are not provided with food-compliant lubricants.

**The requirements of standard EN 1672-2:2020 are not fully met.**

---

#### NOTE

- Change contaminated food-compliant lubricant.
  - Observe information in the safety data sheet from the lubricant manufacturer.
-

## 8.4 Wearing parts

### NOTICE

#### Material damage due to incorrect assembly and disassembly!

- Only disassemble the product to such an extent as is visible in the following "Assembly drawing" section, ▶ 8.5 [43].
- Only allow SCHUNK to perform more extensive repairs.

Position of the wearing parts ▶ 8.5 [43]

Item	Designation
44 *	O-ring
57	Shock absorber
90	Exhaust air throttle
	RST-D 60: M5; ID: 9936160
	RST-D 87: G1/8"; ID: 9936159
	RST-D 134: G1/4"; ID: 9936161

Tab.: Wear parts, can be replaced by the customer

\* Contained in seal kit. ID.-No. of the seal kit, ▶ 1.4 [6].

#### Wear parts which may only be replaced by SCHUNK:

- Seal elements
- Rolling bearing
- Drive components and components in the locking mechanism
- Back stops

Defects in the drive and in the locking mechanism must be rectified by SCHUNK. In this case, contact SCHUNK.

Item	Quantity	Designation	
4	1	Switching plate	Locking
20	2	Locking bolt	
21	2	Guide bushing I	
22	2	Guide bushing II	
8	1	Gear	Drive
11	2	Piston	
26	1	Back stop	Back stop
27	1	Back stop	Back stop, pitch-dependent

Tab.: Other wear parts may only be replaced by SCHUNK

## 8.5 Assembly drawing

The following figure is an example image.  
It serves for illustration and assignment of the spare parts.  
Variations are possible depending on size and variant.

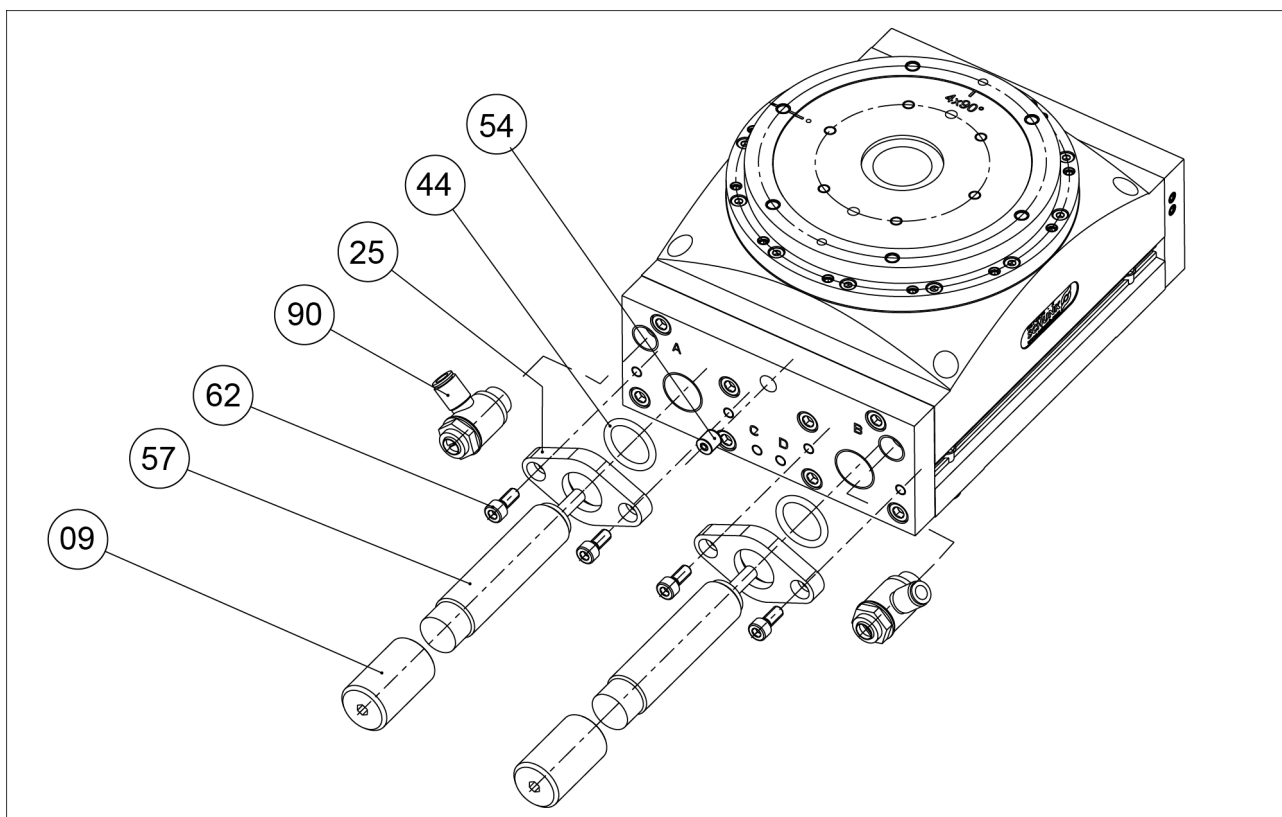

Assembly RST-D

## 9 Translation of the original declaration of incorporation

in terms of the Directive 2006/42/EG, Annex II, Part 1 Section B.

Manufacturer/ Distributor                      SCHUNK SE & Co. KG  
Spanntechnik | Greiftechnik | Automatisierungstechnik  
Bahnhofstr. 106 – 134  
D-74348 Lauffen/Neckar

We hereby declare that the partly completed machine described below

Product designation:                      Ring indexing table / RST-D /pneumatic  
ID number                                      0315500, 0315501, 0315502, 0315503, 0315510, 0315511, 0315512,  
0315513, 0315520, 0315521, 0315522, 0315523, 0315524

meets the following basic occupational health and safety of the Machinery Directive 2006/42/EC:

No. 1.1.1, No. 1.1.2, No. 1.1.3, No. 1.1.5, No. 1.3.2, No. 1.5.3, No. 1.5.4, No. 1.5.6, No. 1.5.8, No. 1.5.10, No. 1.5.11, No. 1.5.13

The partly completed machinery may not be put into operation until it has been confirmed that the machine into which the partly completed machinery is to be installed complies with the provisions of the Machinery Directive (2006/42/EC). The declaration shall be rendered invalid if modifications are made to the product.

Applied harmonized standards, especially:

EN ISO 12100:2010                      Safety of machinery – General principles for design –  
Risk assessment and risk reduction

The special technical documentation according to Annex VII, Part B, belonging to the partly completed machine, has been created.

Person authorized to compile the technical documentation:  
Stefanie Walter, Address: see manufacturer's address

*Signature: see original declaration*

Lauffen/Neckar, March 2024

Dr.-Ing. Manuel Baumeister,  
Head of Systems Engineering,  
Technology & Innovation

## 10 UKCA declaration of incorporation

in accordance with the Supply of Machinery (Safety) Regulations 2008.

Manufacturer/  
Distributor                      SCHUNK Intec Limited  
   Clamping and gripping technology  
   3 Drakes Mews, Crownhill  
   MK8 0ER Milton Keynes

We hereby declare that on the date of the declaration the following partly completed machine complied with all basic safety and health regulations found in the "Supply of Machinery (Safety) Regulations 2008".

The declaration shall be rendered invalid if modifications are made to the product.

Product designation:            Ring indexing table / RST-D / pneumatic  
ID number                            0315500, 0315501, 0315502, 0315503, 0315510, 0315511, 0315512,  
   0315513, 0315520, 0315521, 0315522, 0315523, 0315524

The partly completed machine may not be put into operation until it has been confirmed that the machine into which the partly completed machine is to be installed complies with the provisions of the "Supply of Machinery (Safety) Regulations 2008".

Applied harmonized standards, especially:

EN ISO 12100:2010                Safety of machinery – General principles for design –  
   Risk assessment and risk reduction

The special technical documentation according to Annex VII, Part B, belonging to the partly completed machine, has been created.

Person authorized to compile the technical documentation:  
Marcel Machado, address: refer to manufacturer's address



Lauffen/Neckar, March 2024

Dr.-Ing. Manuel Baumeister,  
Head of Systems Engineering,  
Technology & Innovation

## 11 Information on the RoHS Directive, REACH Regulation and Substances of Very High Concern (SVHC)

### RoHS Directive

SCHUNK products are classified as "large-scale stationary installations" or as "large-scale stationary industrial tools" within the meaning of Directive 2011/65/EU and its extension 2015/863/EU "on the restriction of the use of certain hazardous substances in electrical and electronic equipment (RoHS)", or fulfill their intended function only as part of one. Therefore products from SCHUNK do not fall within the scope of the directive at this time.

### REACH Regulation

Products from SCHUNK fully comply with the regulations of Regulation (EC) No. 1907/2006 "concerning the Registration, Evaluation, Authorization and Restriction of Chemicals (REACH)" and its amendment 2022/477. SCHUNK attaches great importance to completely avoiding chemicals of concern to humans and the environment wherever possible.

Only in rare exceptional cases do SCHUNK products contain SVHC substances on the candidate list with a mass content above 0.1%. In accordance with Article. 33 (1) of Regulation (EC) No. 1907/2006, SCHUNK complies with its duty to "communicate information on substances in articles" and lists the components concerned and the substances used in an overview that can be viewed at [schunk.com/SVHC](https://www.schunk.com/SVHC).

*Signature: see original declaration*

Lauffen/Neckar, March 2024

Dr.-Ing. Manuel Baumeister,  
Head of Systems Engineering,  
Technology & Innovation





**SCHUNK SE & Co. KG**  
Spanntechnik | Greiftechnik | Automatisierungstechnik

Bahnhofstr. 106 – 134  
D-74348 Lauffen/Neckar  
Tel. +49-7133-103-0  
info@de.schunk.com  
schunk.com

Folgen Sie uns | *Follow us*



Wir drucken nachhaltig | *We print sustainable*