

# KONTEC KSC

Maximum precision and process reliability

Superior Clamping and Gripping



# Product Overview



## Gripping Systems

## Clamping Technology



Chuck Jaws



Lathe Chucks



Stationary Workholding



Toolholders



Hydraulic Expansion Technology



VERO-S



TANDEM



ROTA



KONTEC



Tombstones



MAGNOS

# Challenges

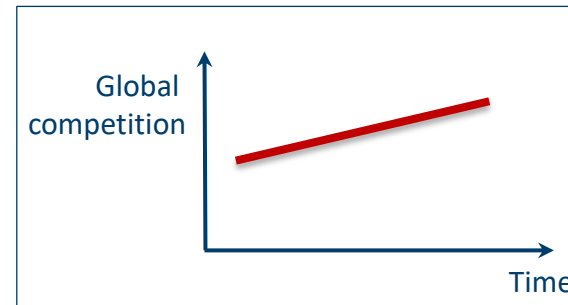
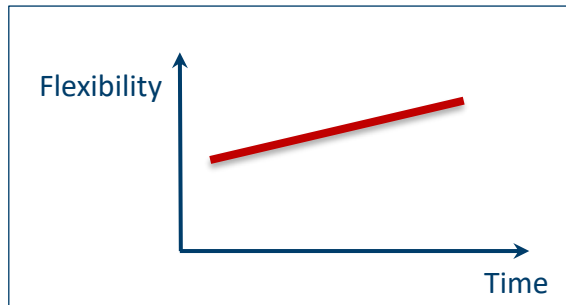
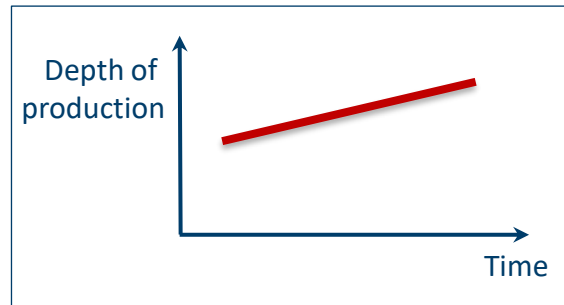

**Increasing importance  
of workpiece clamping**

# SCHUNK Services

## Engineering

- Dimensioning of special plates designed to the manufacturing specifications
- Development of special solutions together with the customer
- FEM analysis for critical components

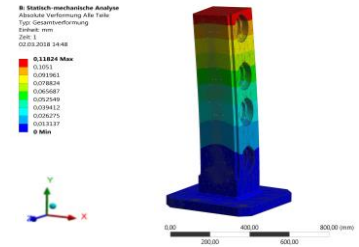

## Testing

- Endurance tests with all new developments
- Abrasion checking
- Measurement of accuracy





## Service

- Initial operation of customer's solution
- Inspection and maintenance
- Repairs









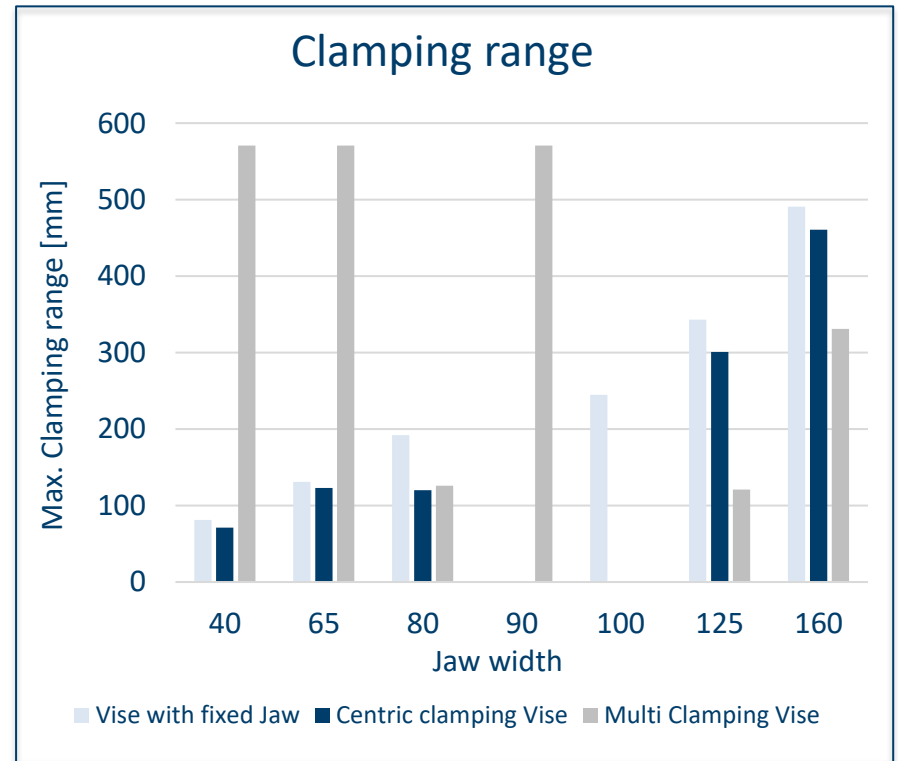
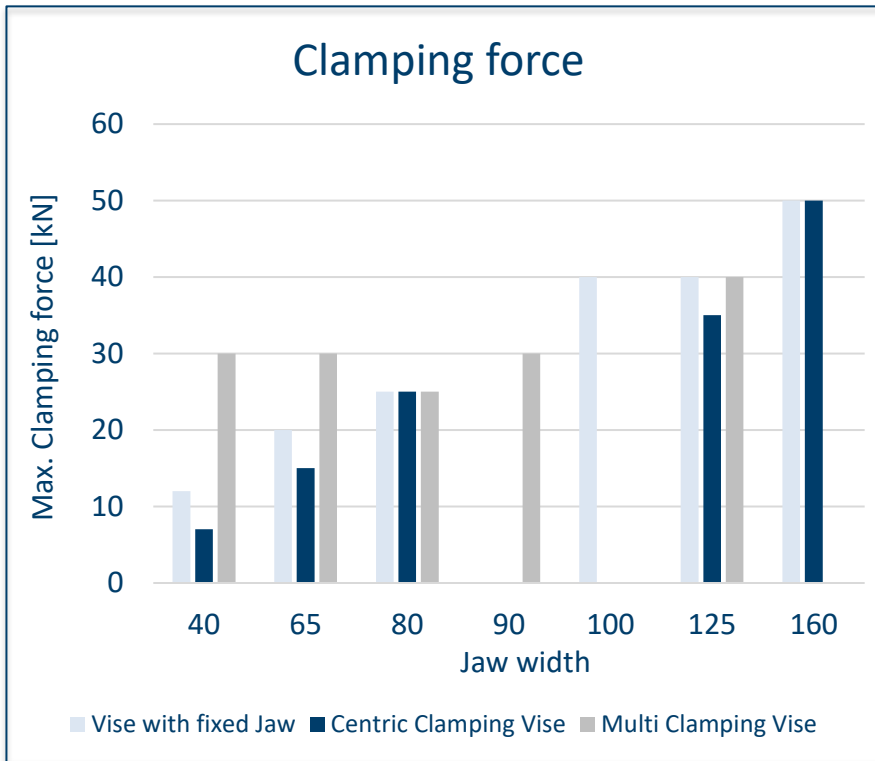

# KONTEC Portfolio

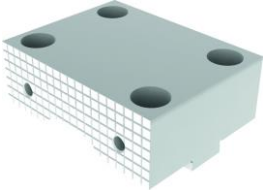
Single-acting Vise	Centric Clamping Vise	Multi Clamping Vise
		
<ul style="list-style-type: none"> <li>• Clamping towards a fixed jaw</li> <li>• Fixed jaw as reference</li> <li>• High repeat accuracy</li> <li>• Especially suitable for workpieces with dimensioning from the side</li> </ul>	<ul style="list-style-type: none"> <li>• Symmetric clamping</li> <li>• Workpiece zero point is always in the center</li> <li>• Optimum accessibility for 5-axis milling</li> <li>• Especially suitable for workpieces with dimensioning from the center</li> </ul>	<ul style="list-style-type: none"> <li>• Clamping of multiple workpieces</li> <li>• Multifunctional usage</li> <li>• Reduction of setup times</li> <li>• Optimum usage of the machine table</li> </ul>

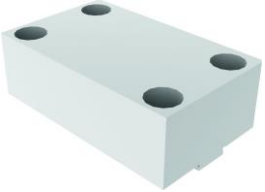
# KONTEC Portfolio

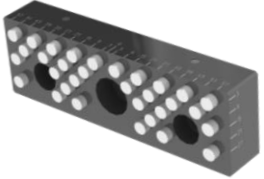
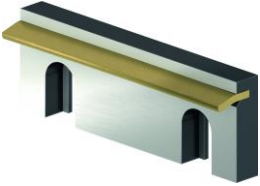

# Fast adaption to new clamping tasks

System Jaws			
Standard reversible jaw	Reversible jaw, grip -grip	Enlarged span width -VS	Aluminium jaw -AL
			
Adapter- and swivel plates -R	5-axis standard jaw -5A / -5A-VS	6-fold jaw -6B	Reversible jaw grip, smooth central jaw -ST
			
Chuck Jaws			
Chuck jaw with locator pin	Spring plate, pull-down jaw	Prismatic jaw	Stepped jaw, grip
			

# KONTEC Overview

Single-acting Vise



Centric Clamping Vise

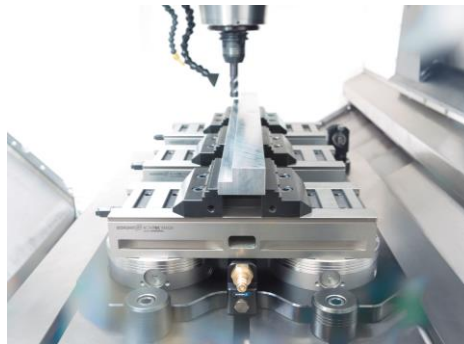

Multi Clamping Vise



# KONTEC Centric Clamping Vise

**KSC**  
Basic Clamping Vise

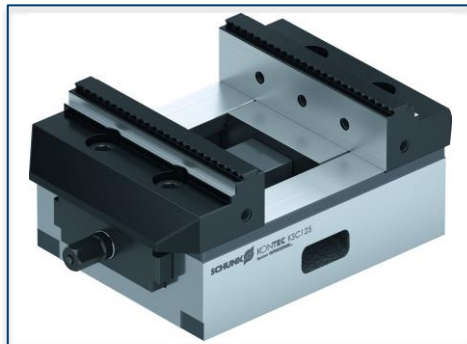

**KSC2**  
Clamping vise for small components



# KONTEC KSC

## Example of application



# KONTEC KSC

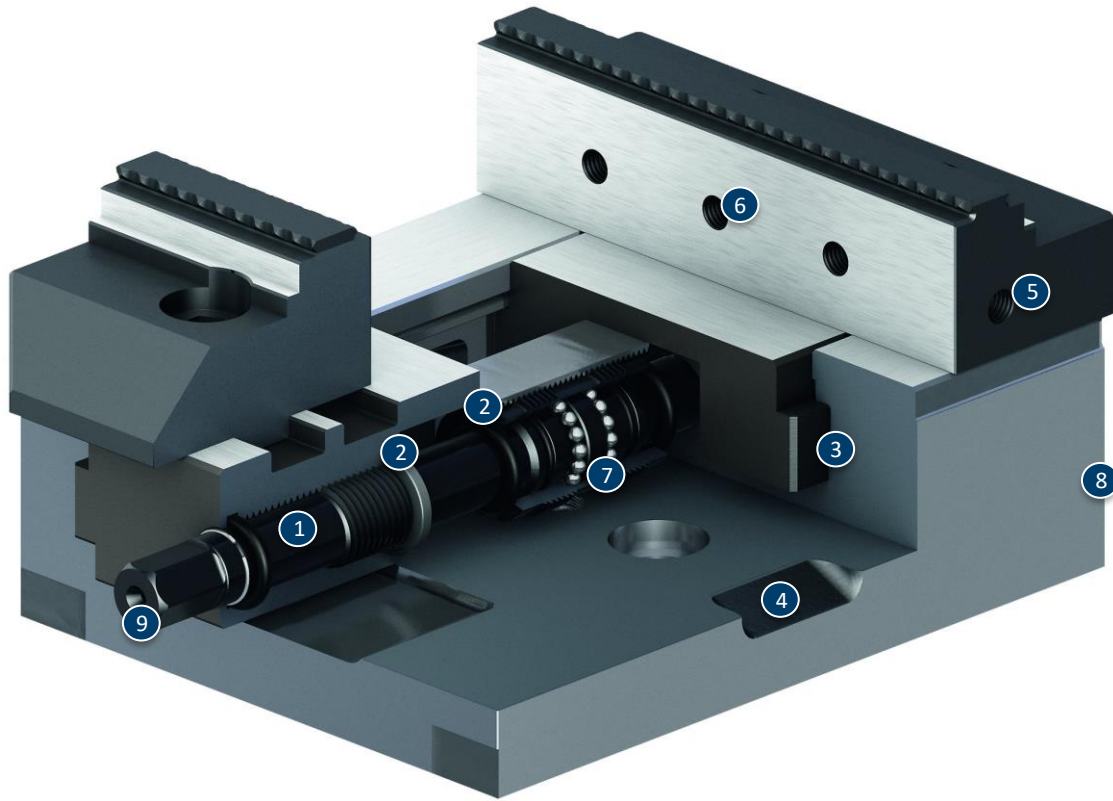

- ① Spindle drive
- ② Double encapsulated spindle
- ③ Long jaw guidance
- ④ Drainage slots
- ⑤ Mounting threads
- ⑥ Standard jaw interface
- ⑦ Ball bearing mounted, backlash-free spindle
- ⑧ Low height
- ⑨ Operation via hexagon connection

# KONTEC KSC

## Double encapsulated spindle

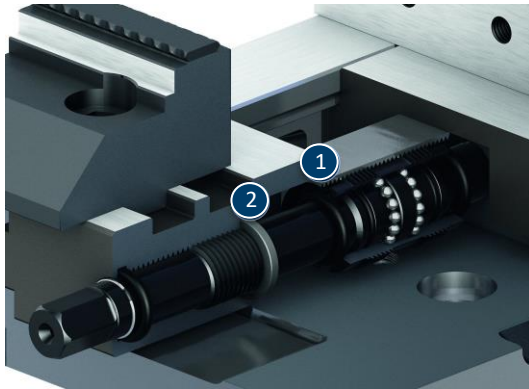

- 1 Sealing on the spindle bearing
- 2 Sealing on the gear

## Actuation via hexagon nut



## Drainage slots

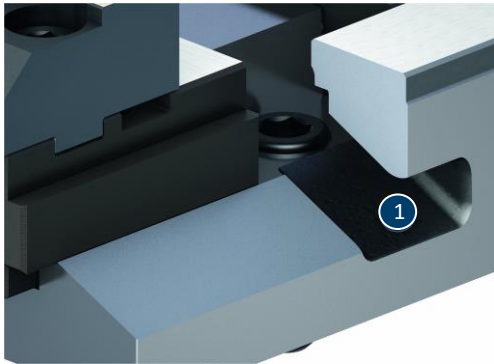

- 1 Drainage slot

## Threads for stops in the base jaws

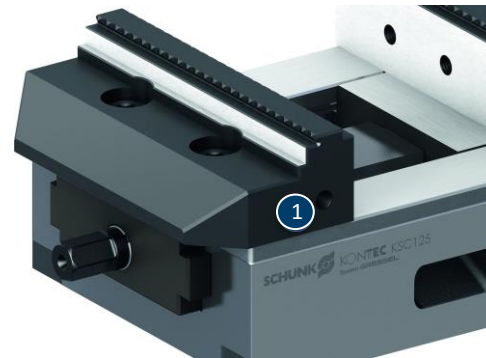

- 1 Thread for stops

# KONTEC KSC

Wide jaw guidance and base jaws fitted into the body

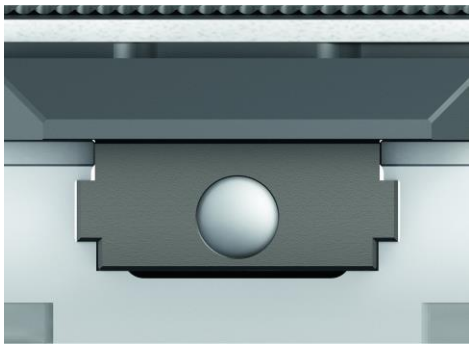

Extremely flat design



Jaw change with just two screws



Mounting options



1 Fastening via quick-change pallet system



2 Fastening via screws

# KONTEC KSC

Floating version



① Floating bearing

# Variants of KONTEC KSC

Technical data	KSC 80-130* <sup>1</sup>	KSC 125-160* <sup>2</sup>	KSC 125-300* <sup>2</sup>	KSC 160-280* <sup>3</sup>	KSC 160-480* <sup>3</sup>
Max. clamping force [kN]	25	35	35	50	50
Max. torque [Nm]	90	100	100	175	175
Weight [kg]	3	6.4	11.8	21	35

\*<sup>1</sup> Additionally available in -grip, -AL and -R

\*<sup>2</sup> Additionally available in -grip, -VS, -AL, -R, -6B and -5A

\*<sup>3</sup> Additionally available in -grip, -AL, -R and -5A

Superior Clamping and Gripping



© 2021 SCHUNK GmbH & Co. KG  
schunk.com