

Installation and Operation Manual

DL5-M and DL5-T PROFINET

Control Module

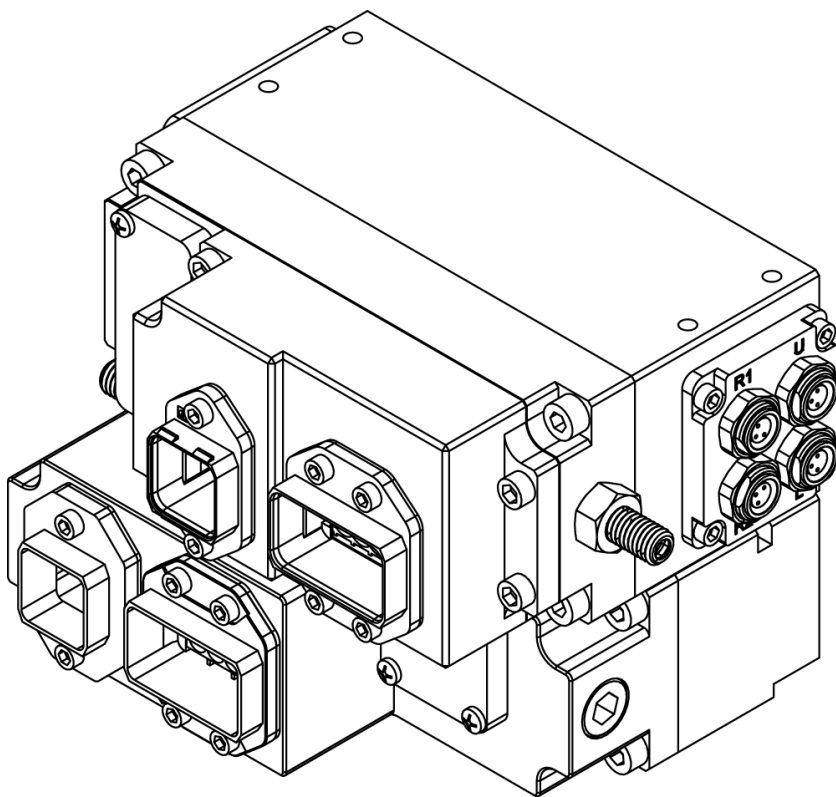

Superior Clamping and Gripping



Imprint

Copyright:

This manual is protected by copyright. The author is SCHUNK GmbH & Co. KG. All rights reserved. Any reproduction, processing, distribution (making available to third parties), translation or other usage - even excerpts - of the manual is especially prohibited and requires our written approval.

Technical changes:

We reserve the right to make alterations for the purpose of technical improvement.

Document number: 0389678

Version: 03.00 | 01/12/2020 | en

© SCHUNK GmbH & Co. KG

All rights reserved.

Dear Customer,

thank you for trusting our products and our family-owned company, the leading technology supplier of robots and production machines.

Our team is always available to answer any questions on this product and other solutions. Ask us questions and challenge us. We will find a solution!

Best regards,

Your SCHUNK team

Customer Management

Tel. +49-7133-103-2503

Fax +49-7133-103-2189

cmg@de.schunk.com



Please read the operating manual in full and keep it close to the product.

Table of Contents

1	Specifications	4
2	Overview	6
2.1	Master Module and Tool Module.....	7
3	Installation	9
3.1	Electrical Connections	10
3.2	Installing DL5-M Control/Signal Module	15
3.3	Remove the DL-K Control/Signal Module.....	16
3.4	Installing DL5-T Control/Signal Module.....	17
3.5	Remove the DL-A Control/Signal Module.....	17
3.6	PROFINET Interface	18
3.7	Utility Schematic.....	18
4	Description	19
4.1	Master Module.....	19
4.1.1	PROFINET Interface Information	19
4.1.2	Integrated Ethernet Switch	25
4.1.3	System Failure and Bus Failure LEDs	25
4.1.4	Ethernet 1 and Ethernet 2 LEDs.....	27
4.1.5	Reset-To-Factory Push-Button.....	27
4.2	Arc Prevention Circuit.....	28
4.2.1	Arc Prevention Circuit Behavior during Coupling	28
4.2.2	Arc Prevention Circuit Behavior during Uncoupling	30
4.3	Tool Module	31
4.4	Safety System	32
5	Operation	35
5.1	Inputs.....	35
5.2	Error Conditions	37
5.3	Recommended Sequence of Operation	40
5.4	Setting the Tool-ID.....	43
6	Maintenance and care	44
6.1	Pin Block Inspection and cleaning	45
6.2	Seal Replacement	46
6.3	DL Device Replacement Procedures.....	47
6.3.1	Replace DL module with a new “out-of-the-box” DL module	47
6.3.2	Replace DL5 module with an already-commissioned DL5 module.....	47
7	Trouble shooting	50
8	Recommended Spare Parts	51
9	Drawings	52
	Glossary	59

1 Specifications

DL5 PROFINET Master Module	
Interface Connections	<p>Auxiliary Power: Push-Pull, 5-Pin</p> <p>PROFINET: Push-Pull RJ45</p> <p>Integrated Tool Changer I/O:</p> <ul style="list-style-type: none"> • 4X M8, 3-pin female connectors supporting Tool Changer Locked, Unlocked, and Ready-to-Lock proximity sensors. <p>Integrated Connection to Valve Adapter Diagnostic Sensors:</p> <ul style="list-style-type: none"> • 1X M8, 3-pin female connectors supporting Valve Adapter proximity sensor • 1X M8, 4-pin female connectors supporting Valve Adapter pressure sensor <p>Integrated Connection to 9121-JR4-M Valve Adapter:</p> <ul style="list-style-type: none"> • 1X 4-Pin Pin Block supporting Latch and Unlatch signals <p>Connection to Valve Adapter Proximity Sensors:</p> <ul style="list-style-type: none"> • 1X M12, 5-Pin female connector supporting connection to RFID based Safety Switch
Electrical Rating	<p>Power Pass-Thru:</p> <ul style="list-style-type: none"> • US1+ and US2+ Power: 10A, 20–29 VDC Note: Arc prevention is applied to US1 and US2 power. <p>Signal Pass-Thru: 3A, 30VDC maximum</p>
*Current Draw	<p>US1 Power: 220mA @ 24VDC: Master and Tool with Locked, RTL1, and RTL2 sensors “on” and Safety Switch activating V1 and V2 Relays.</p> <p>US2 Power: 250 mA @ 24VDC (Solenoid Valve) (only when Locking or Unlocking Tool Changer).</p> <p>Note: Power source for US1 and US2 Power must be a 24VDC certified power supply or equivalent voltage controlled power supply and must be protected by a user installed external 10 A fuse.</p>
Enclosure	IP65

DL5 PROFINET Master Module	
Temperature	32°F to 120°F (0 to 49°C). Note: Lower temperature limit of 0°C based on MSP100 Pressure Sensor lower limit operating temperature of 0°C. Upper temperature limit of 49°C based on MAC Series 48 Valve upper limit operating temperature of 49°C. Reference “JR4 Project Specification” regarding the specifications of the MSP100 Pressure Sensor and MAC Series 48 Valve.
Weight	2.42 lbs (1.10 kg)

DL5 PROFINET Tool Module	
Factory Default Configuration	(5) Independent Tool-ID switches, each reading a (0–9) position (all factory set to Tool Position 1)
Interface Connections	Auxiliary Power: Push-Pull, 5-Pin PROFINET: Push-Pull RJ45
Electrical Rating	Power Pass-Thru: • US1+ and US2+ Power: 10A, 12-30 VDC
	Signal Pass-Thru: 3A, 30VDC maximum
*Current Draw	US1 Power: 220mA @ 24VDC: Master and Tool with Locked, RTL1, and RTL2 sensors “on” and Safety Switch activating V1 and V2 Relays.
Enclosure	IP65
Temperature	32°F to 120°F (0 to 49°C)
Weight	1.86 lbs (0.84 kg)

2 Overview

The DL modules enable the customer to control and communicate with the Tool Changer through a network using a PROFINET interface. A PROFINET node is established on the Master module, but not on the Tool. Control of the Tool Changer is realized through the Master Node along with the reporting of various Tool Changer I/O. The Tool module supports Tool-ID reported through the Master and functions as a pass-through for PROFINET network and power to downstream equipment.

The DL module is to be used in combination with the valve adapter with dual double-solenoid valves, for Latch/Unlatch control of the Tool Changer. When used in combination with the valve adapter, the DL achieves PL d safety reliability in accordance with ISO standard 13849-1. The user is required to provide a pneumatic supply source to the Tool Changer. Please refer to the appropriate manual for specific module and Tool Changer requirements.

The DL-K/DL-A modules are designed with a Safety circuit to allow the Tool Changer to be operated in the safest manner possible. In addition to supporting the standard Tool Changer input signals (Locked, Unlocked, and Ready-to-Lock proximity sensors) the modules also support advanced diagnostic and fault reporting. Refer to Safety System and [Operation](#) [▶ 35] for more information on these attributes.

A standard 5-Pin Push-Pull connector is provided on the Master and Tool modules for interfacing with Auxiliary Power. The power source for US1 and US2 Power must be a 24VDC certified power supply or equivalent voltage controlled power supply and must be protected by a user installed external 10 A fuse. A standard connector is provided on the Master and Tool modules for interfacing with PROFINET. When the Tool Changer is coupled, the Master and Tool modules pass signals via a spring-loaded pin block. A flexible boot surrounds the pin block to seal the connection from moisture and liquid while coupled, Link Beschreibung.

2.1 Master Module and Tool Module

Master Module (DL5-M)

The DL5-M Module has an integrated 4-Pin Valve signal pin block to provide the latch and unlatch signals to the solenoid valves. The master module is equipped with M8 3-Pin connectors for the RTL1, RTL2, Lock, and Unlock sensor connections.

The Master module has integrated M8 3-Pin valve adapter proximity sensor and M8 4-Pin valve adapter pressure sensor connectors as part of the safety functionality. A M12 5-Pin connector provides connection to the Euchner contact-less safety switch that is integrated into the safety circuit.

The Master Module also incorporates an exclusive Arc Prevention Circuit which extends the life of all electrical power contacts by eliminating arcing caused by inductive loads and high inrush current during coupling/uncoupling. Refer to Arc Prevention Circuit for additional information regarding the Arc Prevention Circuit.

The DL5-M Module provides status LED's to visually indicate their operation. A reset button provides the ability to return to factory default settings.

Tool Module (DL5-T)

The DL5-T module requires a JR4-T Spacer Module to align the DL5 Master and Tool modules and mounts to the Tool body of the Tool Changer.

The Tool module employs a series of thumbwheel switches for setting of the Tool-ID input. This allows the customer to distinguish between the different Tools that are being used in a robotic cell or on a production line. The Tool-ID is reported through the Master module bitmap. See [PROFINET Interface Information](#) [► 19] for PROFINET bitmap and detailed I/O information.

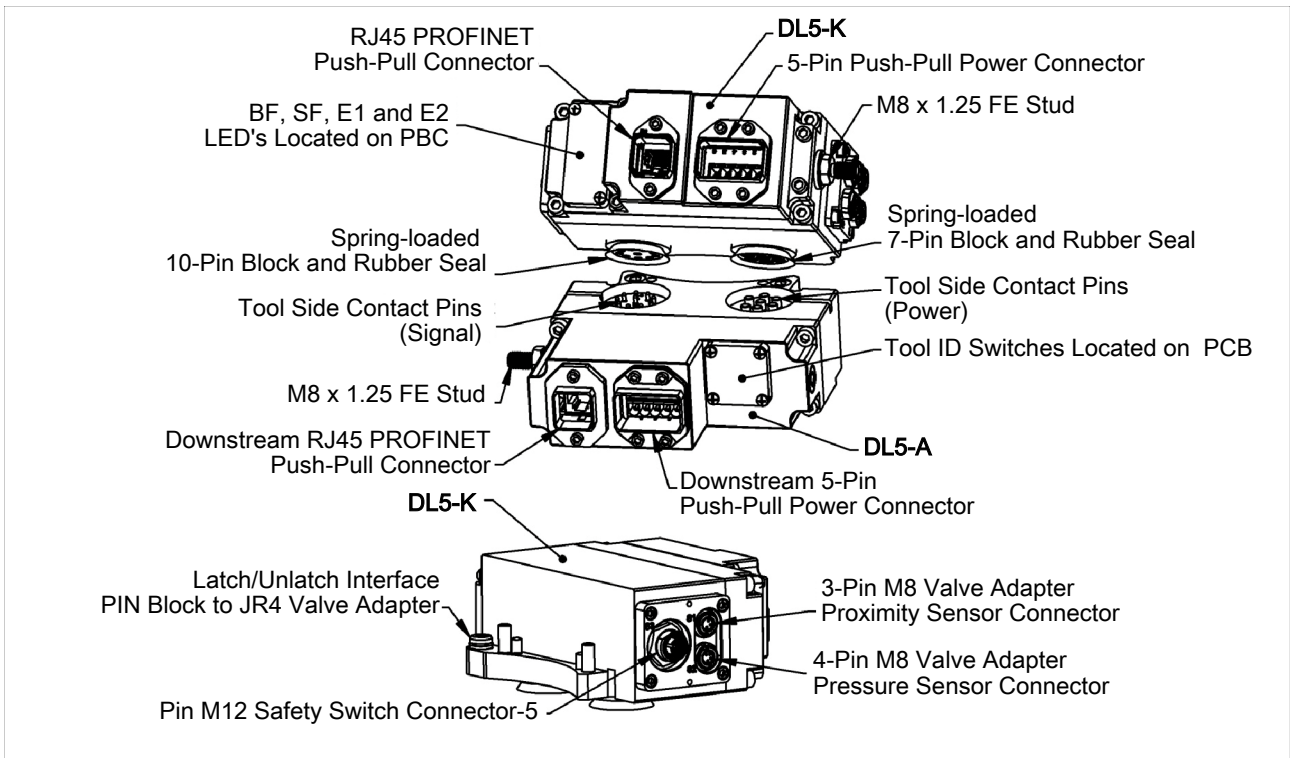

DL5 PROFINET Master and Tool Modules

3 Installation



⚠ WARNING

Do not perform maintenance or repair on Tool Changer or modules unless the Tool is safely supported or placed in the tool stand, all energized circuits (e.g. electrical, air, water, etc.) are turned off, pressurized connections purged and power discharged from circuits in accordance with the customer's safety practices and policies.

Injury or equipment damage can occur with Tool not placed and energized circuits on.

- Place the Tool safely in the tool stand, turn off and discharge all energized circuits, purge all pressurized connections, verify all energized circuits are deenergized before performing maintenance or repair on Tool Changer or modules.

The control/signal modules are typically installed by SCHUNK prior to shipment. The steps below outline the field installation or removal as required. The DL-K Master Module is mounted to the JR4-M valve adapter module on flat A of the Tool Changers Master Plate. The DL-A Tool Module is mounted to the JR4-A Spacer module on flat A of the Tool Changer Tool Plate.

3.1 Electrical Connections

The DL Master and Tool Modules have a 5-Pin Push-Pull Power connector and a Push-Pull RJ45 Ethernet connector. The Pin Assignments are shown in the following figures and tables.

NOTE

The power source for US1 and US2 Power must be a 24VDC certified power supply or equivalent voltage controlled power supply and must be protected by a user installed external 10 A fuse.

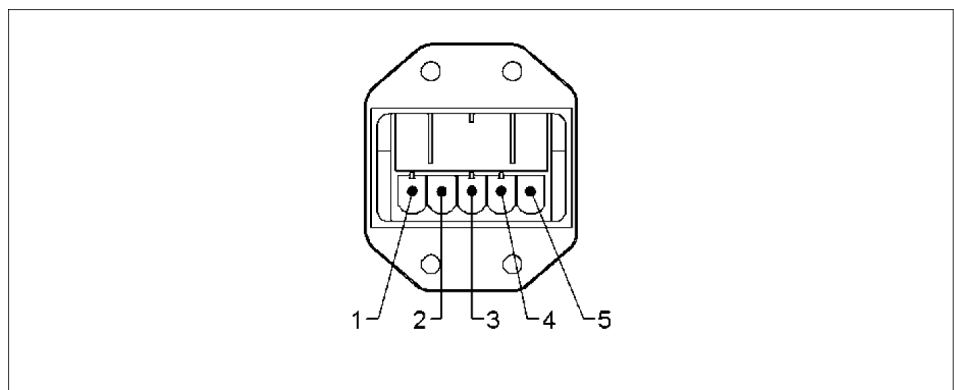

Pin Push-Pull Power Connector

Pin	Signal
1	US1+
2	US1-
3	US2+
4	US2-
5	FE

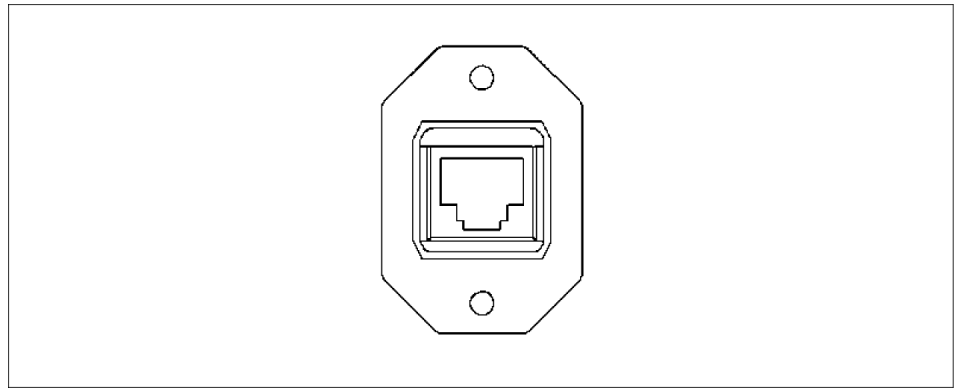

Ethernet Connector

Pin	Signal
1	TX+
2	TX-
3	RX+
4	N/C
5	N/C
6	RX-
7	N/C
8	N/C

The DL5 Master Modules has four M8 3-Pin female connectors for RTL1, RTL2, Locked, and Unlocked connections. The Master module has two connectors to interface with the valve adaptor, an M8 3-Pin female connector to interface with the Proximity sensor and an M8 4-Pin female connector to interface with the Pressure sensor. A M12 5-Pin connector on the Master module is used to connect the Euchner Safety Switch.

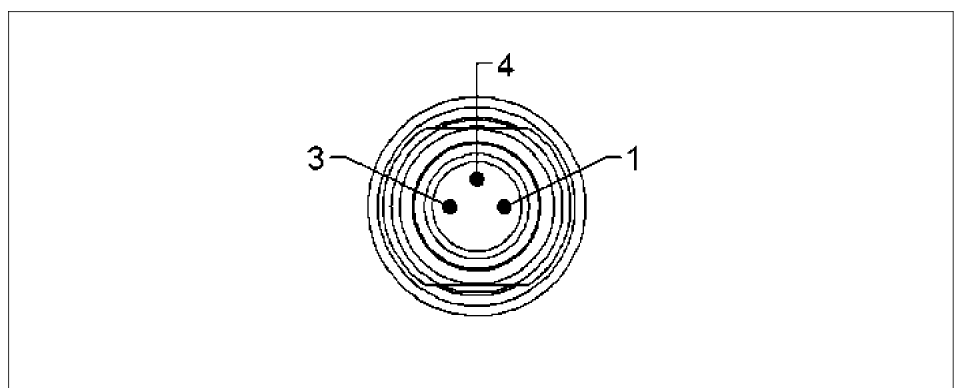

M8 3-Pin female connectors for RTL1, RTL2, Locked, and Unlocked

Pin	Signal
1	US1+
3	US1-
4	Input

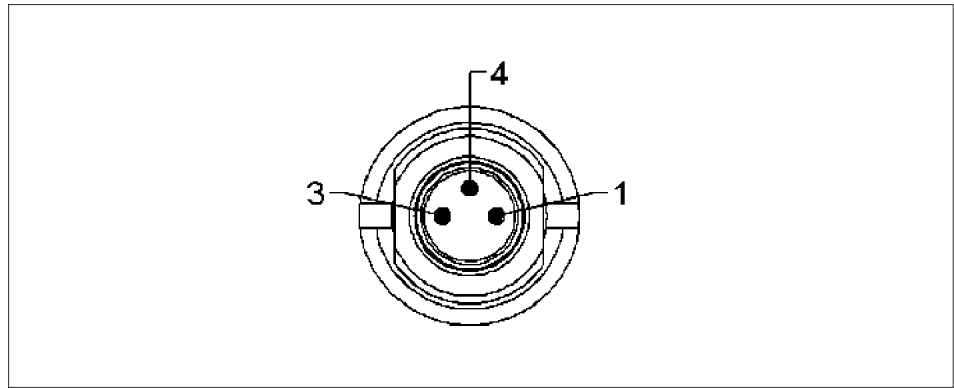

M8 3-Pin Female Valve Adapter Proximity Sensor

Pin	Signal
1	US1+
3	US1-
4	Input

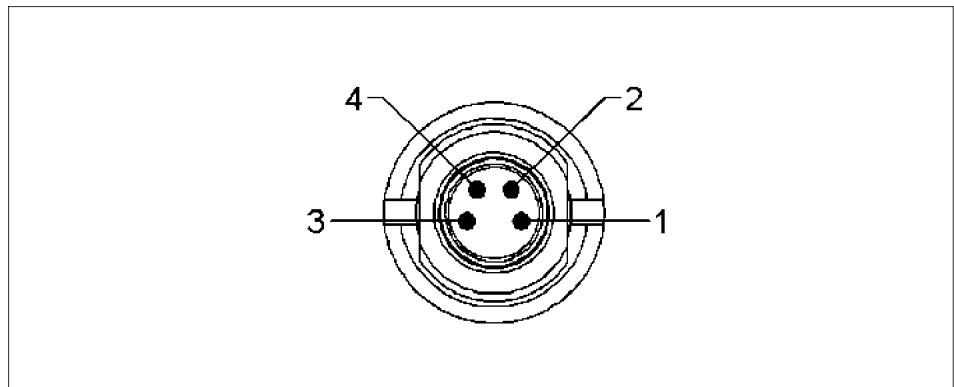

M8 4-Pin Female Valve Adapter Pressure Sensor

Pin	Signal
1	+5V
2	Pressure Output+
3	Pressure Output-
4	GND 5V

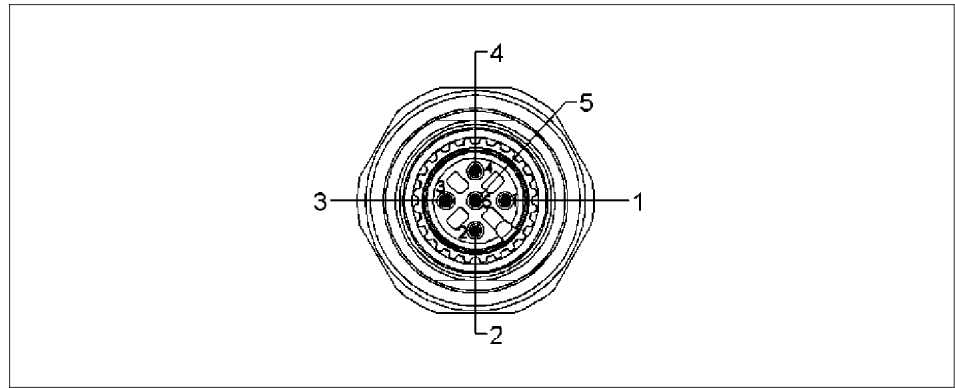

M12 5-Pin Female Euchner Safety Switch Connector

Pin	Signal
1	US1+
2	SSO1
3	US1-
4	SSO2
5	SSFAULT

The Latch and Unlatch signals to the JR4 Valve Adapter are transmitted through a 4-Pin internal pin block to prevent damage or other environmental factors that could cause the signals to short.

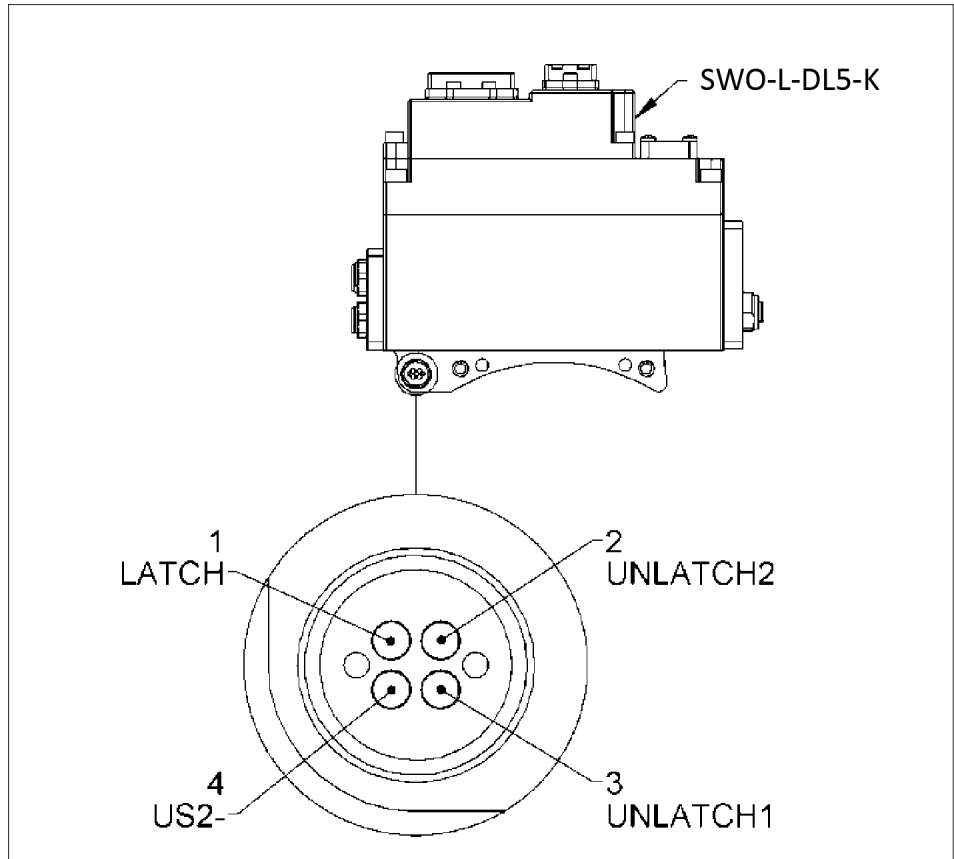

Pin Internal Pin Block

Pin	Signal
1	Latch
2	Unlatch2
3	Unlatch1
4	US2

3.2 Installing DL5-M Control/Signal Module

NOTE

NOTICE: If module being installed is not new “out of the box” and has been previously commissioned refer to [Replace DL5 module with an already-commissioned DL5 module](#) [▶ 47] for instructions.

1. It may be necessary to clean the mounting surface on the JR4 valve adapter prior to installing the module in order to remove any debris that may be present.
2. Using the ledge feature as a guide place the DL5-M Control/Signal Module on the JR4 Valve Adapter mounting surface. Align the control/signal module with the valve adapter using the dowels in the bottom of the ledge feature.
3. If fasteners do not have pre-applied adhesive, apply Loctite 242® to the supplied M6 SHCS fasteners. Install the two M6 socket head screws securing the Control/Signal Module to the Valve Adapter and tighten to 40–70 in-lbs.
4. Connect the pressure sensor and proximity sensor cables to the connectors on the DL5-M Module.
5. Connect the Euchner Safety switch cable to the connector on the DL5-M Module.
6. Connect the RTL1, RTL2, Lock, and Unlock sensor cables to the connectors on the DL5-M Module.
7. Connect the RJ45 Ethernet cable and the 5-Pin Power cable to the connectors on the DL5-M Module.
8. The new module will automatically get the name and IP address of the old module assigned.
9. After a few seconds it should be operating on the network.

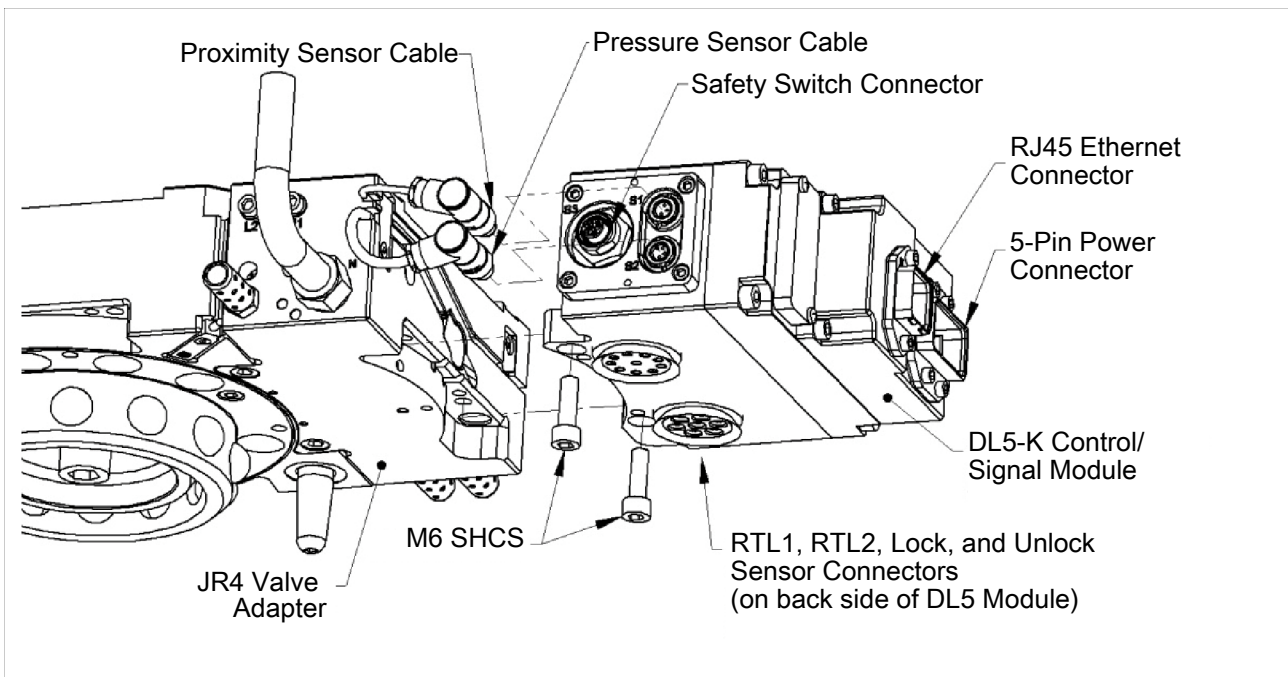

Module Installation and Removal DL5-M Control/Signal Module

3.3 Remove the DL-K Control/Signal Module

1. Remove the pressure and proximity sensor cables from the DL-K Control/Signal Module piggy-backed on the JR4 valve adapter.
2. Disconnect the sensor cables (RT1, RT2, Lock, and Unlock) from the DL-K Control/Signal Module.
3. Disconnect the RJ45 and 5-Pin power cables from the DL-K Control/Signal Module.
4. Support the Control/Signal Module and remove the two M6 SHCS and lower the module until it clears the guide pin, set module aside.

3.4 Installing DL5-T Control/Signal Module

1. It may be necessary to clean the mounting surface on the JR4 Spacer Module prior to installing the module in order to remove any debris that may be present.
2. Using the ledge feature as a guide place the DL5-T Control/Signal Module on the JR4 Spacer Module mounting surface. Align the control/signal module with the Spacer Module using the dowels in the bottom of the ledge feature.
3. If fasteners do not have pre-applied adhesive, apply Loctite 242® to the supplied M6 SHCS fasteners. Install the two M6 socket head screws securing the Control/Signal Module to the Spacer and tighten to 40–70 in-lbs.
4. Connect the RJ45 Ethernet cable and the 5-Pin Power cable to the connectors on the DL5-T Module.

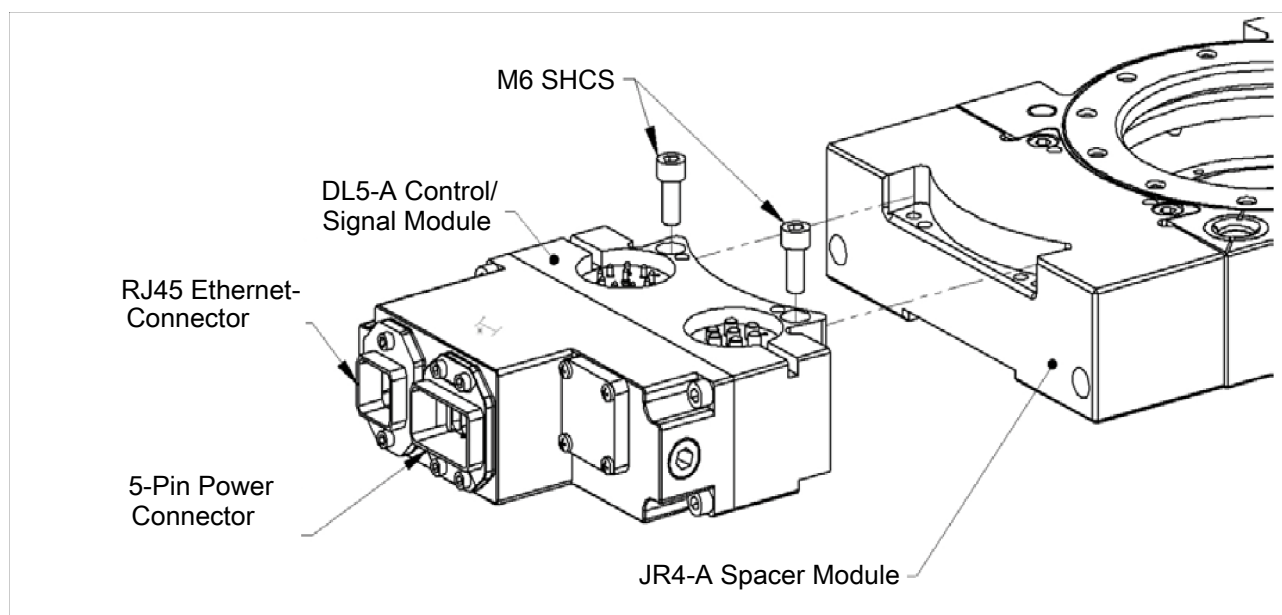

Module Installation and Removal DL5-T Control/Signal Module

3.5 Remove the DL-A Control/Signal Module

1. Disconnect the RJ45, the 5-Pin power cables and the Euchner Safety Switch cable from the DL-A Control/Signal Module.
2. Support the Control/Signal Module and remove the two M6 SHCS and lift up on the module until it clears the guide pin, set module aside.

3.6 PROFINET Interface

The PROFINET interface parameters and I/O bitmaps employed in the DL modules are found in chapter PROFINET Interface Information of the manual. These should be thoroughly understood prior to operating the Tool Changer. A detailed operational sequence is provided in chapter [Recommended Sequence of Operation](#) [▶ 40].

3.7 Utility Schematic

Refer to [Drawings](#) [▶ 52] of this manual for customer interface and wiring details for the DL-K/DL9-A modules.

4 Description

4.1 Master Module

4.1.1 PROFINET Interface Information

The following table lists the PROFINET interface parameters employed in the DL5 Master module.

PROFINET Interface Parameters

Parameter	Description
DCP	supported
Fast Startup	supported
Used Protocols (subset)	UDP, IP, ARP, ICMP (Ping)
Topology recognition	LLDP, SNMP V1, MIB2, physical device
VLAN- and priority tagging	yes
Context Management	by CL-RPC
Minimum cycle time	2ms
Baud rate	100 MBit/s
Data transport layer	Ethernet II, IEEE 802.3

A GSDML file for the Master node is available by e-mail. Reference the part number: DL5-M Node GSDML file Robot input and output bitmaps for the Master node are provided in the following tables "I/O Bitmap, Robot Inputs from DL5-K Module" and "I/O Bitmap, Robot Outputs to DL5-K Module".

I/O Bitmap, Robot Inputs from 9121-DL5-M Module

Byte	Bit#	Designation	Description/Function
0	0	Locked	Tool Changer is locked
	1	Unlocked	Tool Changer is unlocked
	2	US1_Power_Present	US1 supply voltage on robot side within the allowable range of 20.4 to 28.8 V
	3	US2_Power_Present	US2 supply voltage on robot side within the allowable range of 20.4 to 28.8V
	4	RTL1	Ready-to-Lock Prox1 I/P
	5	RTL2	Ready-to-Lock Prox2 I/P
	6	TOOL-PRESENT	Bit indicating Master and Tool are in electrical contact.
	7	Tool Power Is On	Indicates that Arc Prevention Circuit is turned ON and power is provided to the Tool

Description

Byte	Bit#	Designation	Description/Function
1	0	Unlatch Enabled	Unlatch Enabled Status Information
	1	SSO_1	Input from safety switch that indicates it is safe to unlatch the tool. Should always agree with SSO_2
	2	SSO_2	Input from safety switch that indicates it is safe to unlatch the tool. Should always agree with SSO_1
	3	SSFAULT	Input from safety switch that indicates the switch detected a fault condition. This bit indicates the system is unsafe.
	4	V1RELAY	Indicates that safety switch has activated safety relay 1. Should agree with SSO_1.
	5	V2RELAY	Indicates that safety switch has activated safety relay 2. Should agree with SSO_2.
	6	AP2_COMM_ERROR	AP1 lost communication to AP2
	7	UNSAFE_LATCH	Unlatch Rejected Due to Unsafe Condition Present
2	0	EVERYTHING IS OK	Overall Status Bit. Is high as long as there is no error.
	1	ERROR_ON_LATCH	Overload or short circuit on Latch Output
	2	ERROR_ON_UNLATCH 1	Overload or short circuit on Unlatch1 Output
	3	ERROR_ON_UNLATCH 2	Overload or short circuit on Unlatch2 Output
	4	Lock/Unlock Sensor Fault	Lock & Unlock Inputs True at the same time or swapped lock & unlock sensors or bad sensors or no latch/unlatch motion.
	5	TOOL-ID_ERROR	Tool-ID Communication Timeout
	6	UNSAFE_LATCH	User attempted to latch when unsafe. Reset at next rising edge of latch command.
	7	SYSTEM_IS_UNSAFE	Any APx_COMM_ERROR, APx_MISMATCH_ERROR, APx_SAFETY_ERROR, SSO_FAULT sets this bit. Cannot be reset except by power cycle.
3	0	Tool ID Switch2 Bit1	
	1	Tool ID Switch2 Bit2	N/A
	2	Tool ID Switch2 Bit4	N/A
	3	Tool ID Switch2 Bit8	N/A
	4	Tool ID Switch1 Bit1	N/A
	5	Tool ID Switch1 Bit2	N/A
	6	Tool ID Switch1 Bit4	N/A
	7	Tool ID Switch1 Bit8	N/A

Byte	Bit#	Designation	Description/Function
4	0	Tool ID Switch4 Bit1	N/A
	1	Tool ID Switch4 Bit2	N/A
	2	Tool ID Switch4 Bit4	N/A
	3	Tool ID Switch4 Bit8	N/A
	4	Tool ID Switch3 Bit1	N/A
	5	Tool ID Switch3 Bit2	N/A
	6	Tool ID Switch3 Bit4	N/A
	7	Tool ID Switch3 Bit8	N/A
5	0	Tool-ID Switch5 Bit1	N/A
	1	Tool-ID Switch5 Bit2	N/A
	2	Tool-ID Switch5 Bit4	N/A
	3	Tool-ID Switch5 Bit8	N/A
	4	VALVE_ERROR	Valve or pressure sensor defect. Logical OR of APx_VALVE_ERROR bits.
	5	CROSS_MONITORING_ERROR	Safety System detected mismatch. Logical OR of the APx_INP_MISMATCH, APx_OUTP_MISMATCH, and AP2_COMM_ERROR bits.
	6	PRESSURE_TOO_HIGH	Pressure sensor reports an unlatch pressure higher than the maximum system rating. Reset with “clear errors” output bit or with next unlatch command that progresses to turning on UNLATCH_VALVE_CTRL1 (in order to supply air to the pressure sensor).
7	PRESSURE_TOO_LOW	Pressure sensor report an unlatch pressure lower than the minimum system rating. Reset with “clear errors” output bit or with next unlatch command that progresses to turning on UNLATCH_VALVE_CTRL1 (in order to supply air to the pressure sensor).	
6	0	Minor Revision Bit0	uC firmware revision
	1	Minor Revision Bit1	uC firmware revision
	2	Minor Revision Bit2	uC firmware revision
	3	Minor Revision Bit3	uC firmware revision
	4	Major Revision Bit0	uC firmware revision
	5	Major Revision Bit1	uC firmware revision
	6	Major Revision Bit2	uC firmware revision
	7	Major Revision Bit3	uC firmware revision

Description

Byte	Bit#	Designation	Description/Function
7	0	Raw Locked Sensor	Direct mirror of locked proximity sensor.
	1	Raw Unlocked Sensor	Direct mirror of unlocked proximity sensor.
	2	Valve Proximity Sensor	Shows status of valve position.
	3	Reserved	N/A
	4	AP1_VALVE_ERROR	Valve 2 opening or closing at the wrong time.
	5	AP1_OUTP_MISMATCH	AP1 detects that AP2 has come to a different decision than AP1 regarding a safety-critical motion, or AP1 sees Unlatch_valve_control_2 is different than expected.
	6	AP1_INP_MISMATCH	AP1 detects that AP2 reports different input values than AP1 sees.
	7	MEMORY_FAILURE	N/A
8	0	Reserved	N/A
	1	Reserved	
	2	Reserved	
	3	RTL1/RTL2 mismatch	
	4	Firmware Version Mismatch	
	5	Reserved	
	6	Reserved	
	7	Reserved	
9	0	AP2_Mismatch_Error	N/A
	1	AP2_Comm_Error	N/A
	2	AP2_Memory_Failure	N/A
	3	AP2_VALVE_ERROR	Position sensor does not meet expectations
	4	AP2_ERROR_ON_UNLATCH2	Overload on Unlatch 2 output was detected.
	5	PRESSURE_DISCONNECTED	N/A
	6	AP2_Memory_Tests_Complete	N/A
	7	Safe_to_Unlatch_AP2	N/A

Byte	Bit#	Designation	Description/Function
10	0	AP2_SSO_2	N/A
	1	AP2_V1Relay	N/A
	2	AP2_V2Relay	N/A
	3	AP2_SSFAULT	Position sensor does not meet expectations
	4	AP2 Unlatch_ Valve_Control_2	Overload on Unlatch 2 output was detected.
	5	AP2_Valve_Position	Internal bit indicating that the pressure sensor is disconnected and/or that there are broken wires in the sensor cable
	6	AP2_Version_Error	N/A
	7	AP2_Safety_Error	N/A
11	0	Pressure Reading Bit 8	N/A
	1	Pressure Reading Bit 9	
	2	Unused	
	3	Unused	
	4	Unused	
	5	Unused	
	6	Unused	
	7	Unused	
12	0	Pressure Reading Bit 0	N/A
	1	Pressure Reading Bit 1	
	2	Pressure Reading Bit 2	
	3	Pressure Reading Bit 3	
	4	Pressure Reading Bit 4	
	5	Pressure Reading Bit 5	
	6	Pressure Reading Bit 6	
	7	Pressure Reading Bit 7	
13	0	Unused	N/A
	1		
	2		
	3		
	4		
	5		
	6		
	7		

Description

Byte	Bit#	Designation	Description/Function
14	0	Minor Version Number of AP2 [0:4]	AP2 Firmware Revision Number
	1		
	2		
	3		
	4	Major Version Number of AP2 [0:4]	
	5		
	6		
	7		
15	0:07	Reserved	Reserved

I/O Bitmap, Robot Outputs to 9121-DL5-M Module

Byte	Bit#	Designation	Description/Function
1	0	Latch	Request Lock
	1	Unlatch	Request Unlock
	2	Spare	Spare O/P (Reserved)
	3	Clear Errors	Reset errors, allow affected I/O to be reactivated
	4	Soft Start Enable	Enables the soft start functionality
	5	Re-Sync Valves	re-sequence the dual valves. This will cause the tool changer to latch and set an error. A clear error is necessary afterwards
	6	Direct Power Control Enable	Arc Prevention Override (ATI use only)
	7		(Reserved)
2 to 8	(Reserved)		

4.1.2 Integrated Ethernet Switch

The DL-K Master Module provides an integrated 2-port Ethernet switch which supports the following:

- Transmission rate 100 MBit/s
- Interface type 100 BASE-TX, isolated
- Half duplex/Full duplex supported .
- Auto-Negotiation supported
- Auto-Crossover supported

4.1.3 System Failure and Bus Failure LEDs

When the module are coupled and functioning properly, the DL-K LEDs should display as shown in the figure with some blinking.

LED Display of Properly Functioning Coupled Modules



The System Failure (SF) status LED is identified on the module as “SF”. It provides device status for power and proper operation. Refer to the following table for an outline of this LED’s operation. The Bus Failure (BF) status LED is identified on the module as “BF”. It provides PROFINET status information. Refer to the following table for an outline of this LED’s operation.

Description

DL-K SF status LED

Status	SF LED	Note
No Power	Off	No power applied. Check if voltage is 24 VDC.
Operational	Green	Normal operation
Fault	Red	One of the following faults has occurred: - Internal Diagnostic Error
Fault	Red blinking	Reset To Factory Push Button was pressed or one of the following faults has occurred: - Communication error with tool module - Input power failure

DL-K BF status LED

Status	SF LED	Note
Off Line	Off	Device not on line. Device may not have an IP address or may be powered off.
Operational	Green	Normal operation
Not OK	RED	No configuration
Not OK	Red blinking	No data exchange.

4.1.4 Ethernet 1 and Ethernet 2 LEDs

The Ethernet LEDs provide information about link status and activity on the ports of the integrated Ethernet switch.

- The Ethernet 1 LED displays the status of the robot-side Ethernet port (refer to "Master Module Ethernet 1 LED").
- The Ethernet 2 LED displays the status of the Tool-side Ethernet port (refer to "Master Module Ethernet 2 LED").

Master Module Ethernet 1 LED

Status	SF LED	Note
No Link	Off	The Master module has no connection to the Ethernet.
Link	Green	The Master is connected to the Ethernet but there is currently no data exchange activity.
Active RX/TX	Blinking Amber	There is sporadic data exchange activity with the Ethernet.
PROFINET connection established	Amber	There is continuous data exchange activity with the Ethernet.

Master Module Ethernet 2 LED

Status	SF LED	Note
No Link	Off	There is no Ethernet device connected to the tool module.
Link	Green	There are one or more Ethernet devices connected to the Tool module but there is currently no data exchange activity.
Active RX/TX	Blinking Amber	There is sporadic data exchange activity with the Ethernet.
PROFINET connection established	Amber	There is continuous data exchange activity with the Ethernet.

4.1.5 Reset-To-Factory Push-Button

A push-button, located under the LED window cover between the E2 and BF LED allows the user to perform a "Reset-To-Factory" function which clears the PROFINET Name Of Station and the module's IP address. This is useful when already configured devices get swapped or a broken device gets replaced by an already configured device. See Section [DL Device Replacement Procedures](#) [▶ 47] for a detailed device replacement procedure.

After the push-button was pressed the SF LED will blink red, indicating that with the next power cycle the Name of Station and IP address will be cleared.

Make sure to re-apply the LED window cover after access to the push-button is not needed anymore.

4.2 Arc Prevention Circuit

The DL Module incorporates SCHUNK's exclusive Arc Prevention Circuit. The Arc Prevention Circuit extends the life of all electrical power contacts by eliminating arcing caused by inductive loads and high inrush current during coupling/uncoupling. The Arc Prevention Circuit makes it possible to couple/uncouple without switching power off and prevents damage to the contacts.

In the DL Module, the Arc Prevention Circuit controls the ON/OFF status of the following two power signals:

- Input and Logic power US1+
- Output power US2+

The behavior of the Arc Prevention circuit is more fully described in the following sections.

4.2.1 Arc Prevention Circuit Behavior during Coupling

The behavior of the Arc Prevention circuit during coupling can be more clearly understood by referring to the figure below "Power-On Timing", which shows the power-on timing diagram for the Arc Prevention Circuit. Starting at the top of the diagram, the LATCH command is issued thus initiating locking of the Master and Tool. Soon after locking is initiated, electrical contact between Master and Tool Pin Contacts occurs (this time is designated t_1 in the diagram). The magnitude of time t_1 is a function of many factors including the weight of the EOAT, the distance between the Master and Tool when the LATCH command is issued, how well the Master and Tool are aligned during pick-up, etc.

As soon as electrical contact is made and the LATCH command is issued, the Arc Prevention Circuit will turn on US1 and US2 power. The time delay between when the electrical contacts become fully engaged to when power is actually available to the EOAT (time t_2 in the diagram) is less than 100ms.

Important: The Arc Prevention Circuit will only allow power to pass to the Tool after the LATCH command has been issued and the Master and Tool module's electrical contacts are fully engaged.

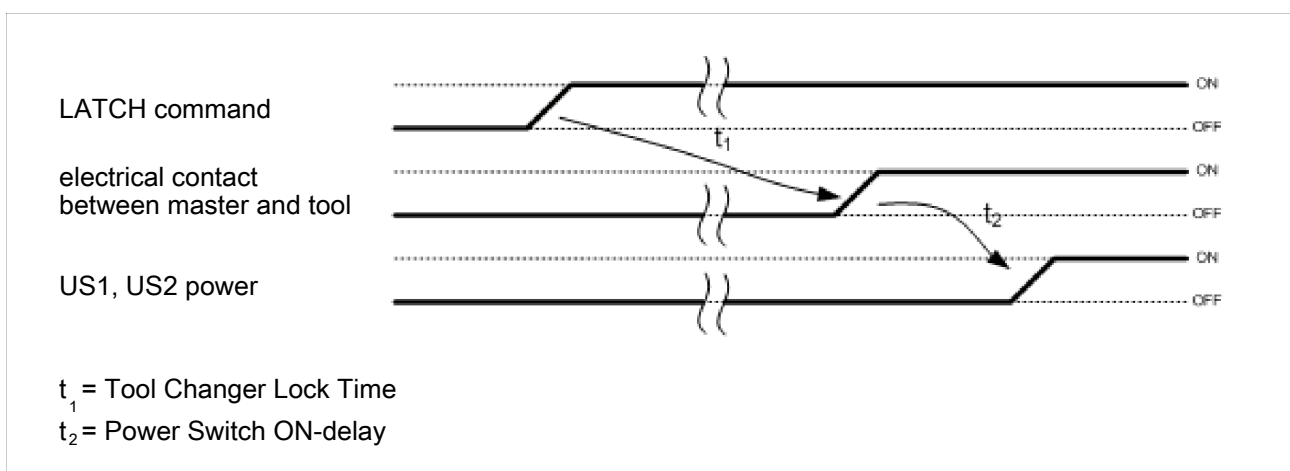

Power-On Timing

4.2.1.1 Soft Start during Coupling

High current spikes can cause voltage drops on the power supply and potentially may lead to network faults. The Arc Prevention Circuit has an SCHUNK exclusive Soft Start feature that pulses the power on gradually in the beginning, preventing the large current spike that would otherwise occur if there were only one hard on signal. This results in a series of much smaller current spikes and prevents significant voltage drops on the network power. The figure below shows how the Soft Start feature effectively reduces the voltage drop on network power.

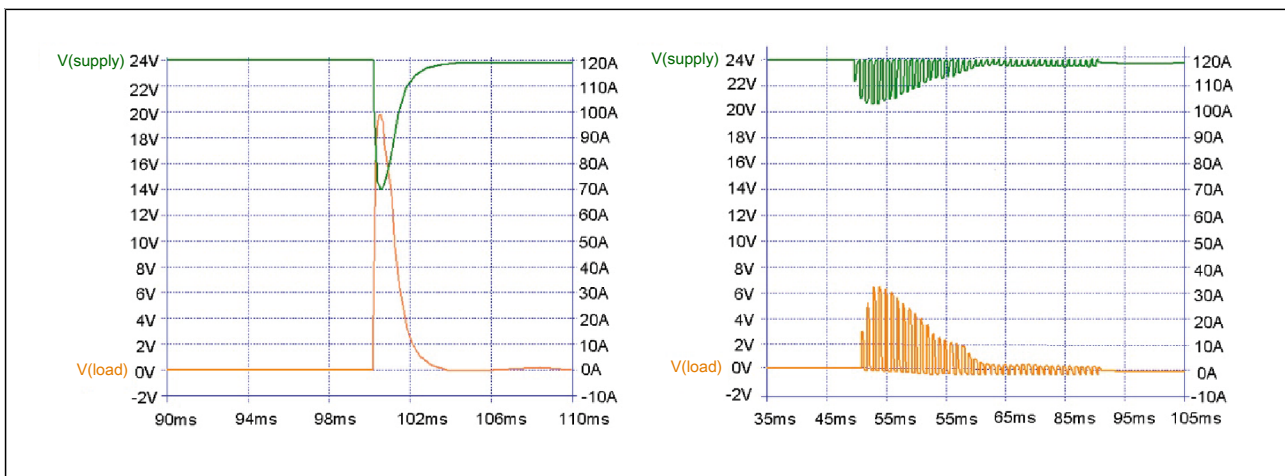

Soft Start Feature

4.2.2 Arc Prevention Circuit Behavior during Uncoupling

The behavior of the Arc Prevention Circuit during uncoupling can be more clearly understood by referring to the figure below, which shows the power-off timing diagram for the Arc Prevention Circuit. Starting at the top of the diagram, the UNLATCH command is issued thus initiating uncoupling of the Master and Tool.

Immediately after the UNLATCH command is issued, the Arc Prevention Circuit will turn off US1 and US2 power. The power-off time delay between the UNLATCH command and the switching off of power (designated t_3 in the diagram) is less than 50ms.

Some time after power is turned off and the Master and Tool begin to separate, electrical contact between Master and Tool Pin Contacts will be lost. This occurs with a delay, designated t_4 in the diagram, after the UNLATCH command is issued. The magnitude of time t_4 is a function of many factors, including the weight of the EOAT, the friction between Master and Tool alignment pins, etc. but is usually not shorter than 100ms.

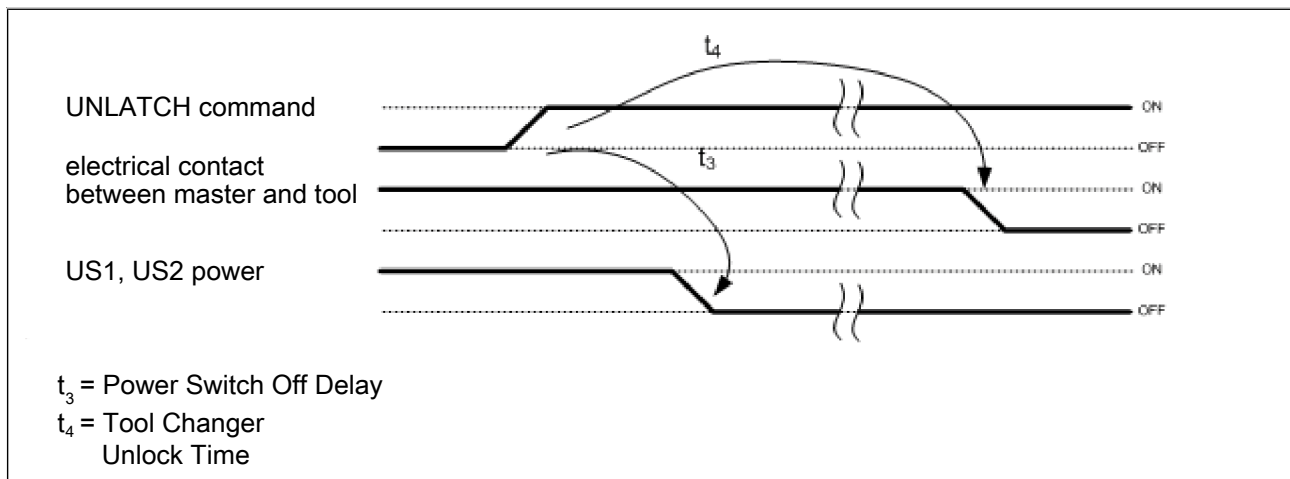

Arc Prevention Circuit Power-Off Timing

4.3 Tool Module

The Tool module utilizes a patented, rapid communication method to report the Tool-ID information from the pushbutton switches to the Master module as soon as the Tool Changer is coupled.

Typically the Tool-ID information is available to the Master within 150ms from the time the changer is coupled.

Five pushbutton switches are provided on the Tool module for setting of a Tool-ID number.

If the plastic window and seal above the Tool-ID switches are removed, ensure the seal and window are re-positioned correctly to prevent a leakage path to the module inside.

The Tool ID is available to the Master within 250ms from the time the changer is coupled; otherwise a Tool-ID_Error shall be set in the bit map. If a Tool is not present the Tool ID is set to FFFFF. If the Master and Tool are coupled and the Tool ID fails to be reported, a Tool-ID_Error shall be set.

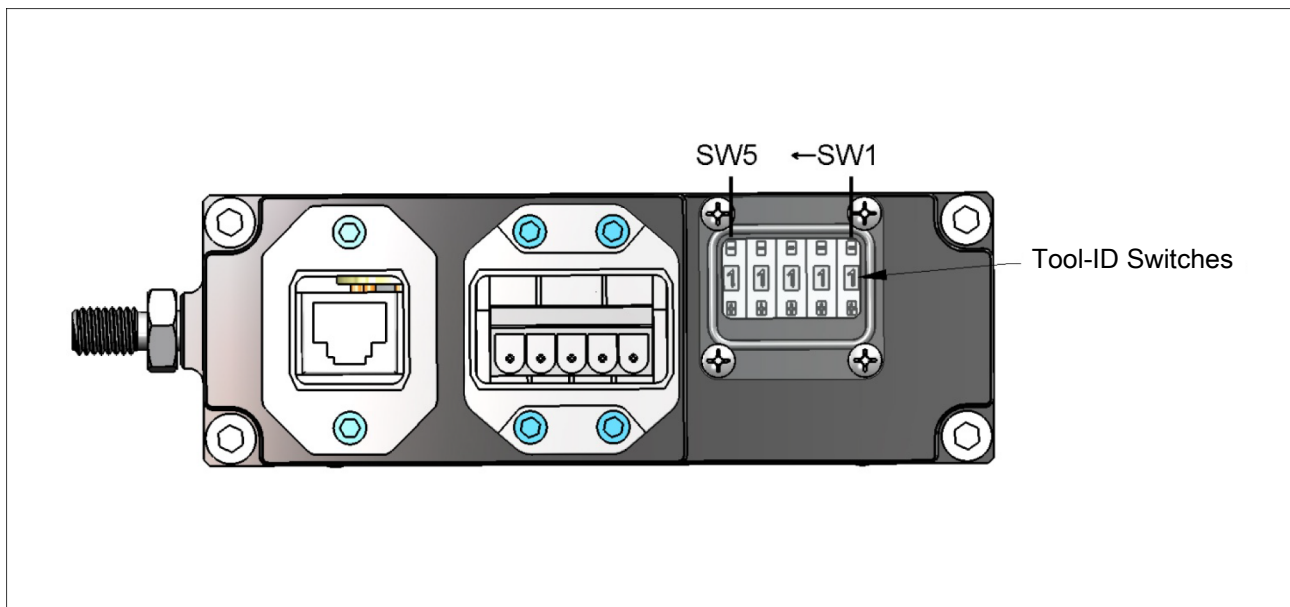

DL5 Tool Module, Tool-ID Switch Settings

(Refer to the bitmap in Table 3.2 for details of how the Tool-ID is reported)

4.4 Safety System

The DL-K module in conjunction with the JR4/JU4 valve adapter is designed with special features to achieve a PL d safety reliability level in accordance with ISO standard 13849-1. The safety system is designed to avoid unintentional Tool release, integrating the Euchner contact-less safety switch, two pneumatically interconnected solenoid valves, dual relays, and two cross-monitoring processors into the safety circuit.

The two cross-monitoring processors in the DL-K mModule will determine, based on the status of all the safety-related inputs and outputs, when it is safe to execute an Unlatch command. The processors are linked by hardwired I/O, if one processor detects a condition that differs from the other processor, its control logic will declare a fault preventing the unlatch output. When the Tool is positioned safely in the tool stand or storage location, the Euchner safety switch outputs will close the V1 and V2 relays allowing the Unlatch command to pass from the Application Processors to the solenoid valves.

A second set of contacts on the V1 and V2 relays also provide diagnostics to the Application Processors. The JR4/JU4 Valve Adapter is equipped with two double-solenoid valves. Pressure and proximity sensor outputs provided by the Valve Adapter are evaluated by the Application Processors for diagnostic purposes.

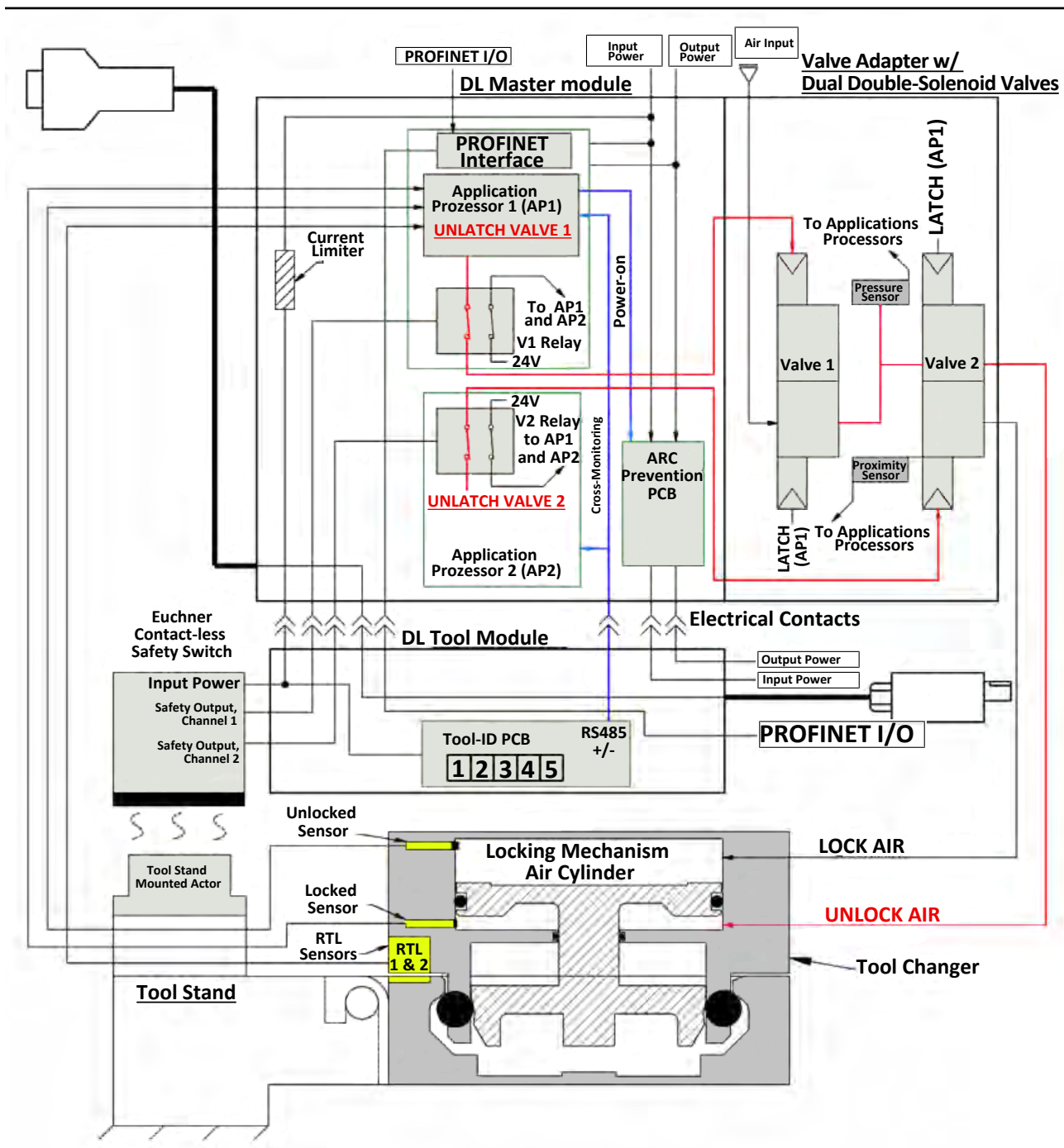

The safety switch (not included with module) is mounted to the DL-A module using a mounting bracket that can be supplied by SCHUNK. The actuator is mounted to the tool stand using an adjustable mounting bracket. The safety switch is connected to the DL-K module by a five conductor M12 cable. Refer to the JR4/JU4/JU5/JT7 Valve adapter manual for detailed information on the dual double solenoid valve functionality.



⚠ CAUTION

It is required to use a PL e rated contact-less safety switch such as the Euchner CES-AP with the DL module.

Use of unapproved switches will void the PL d safety rating.

- Contact SCHUNK before using another safety rated switch.

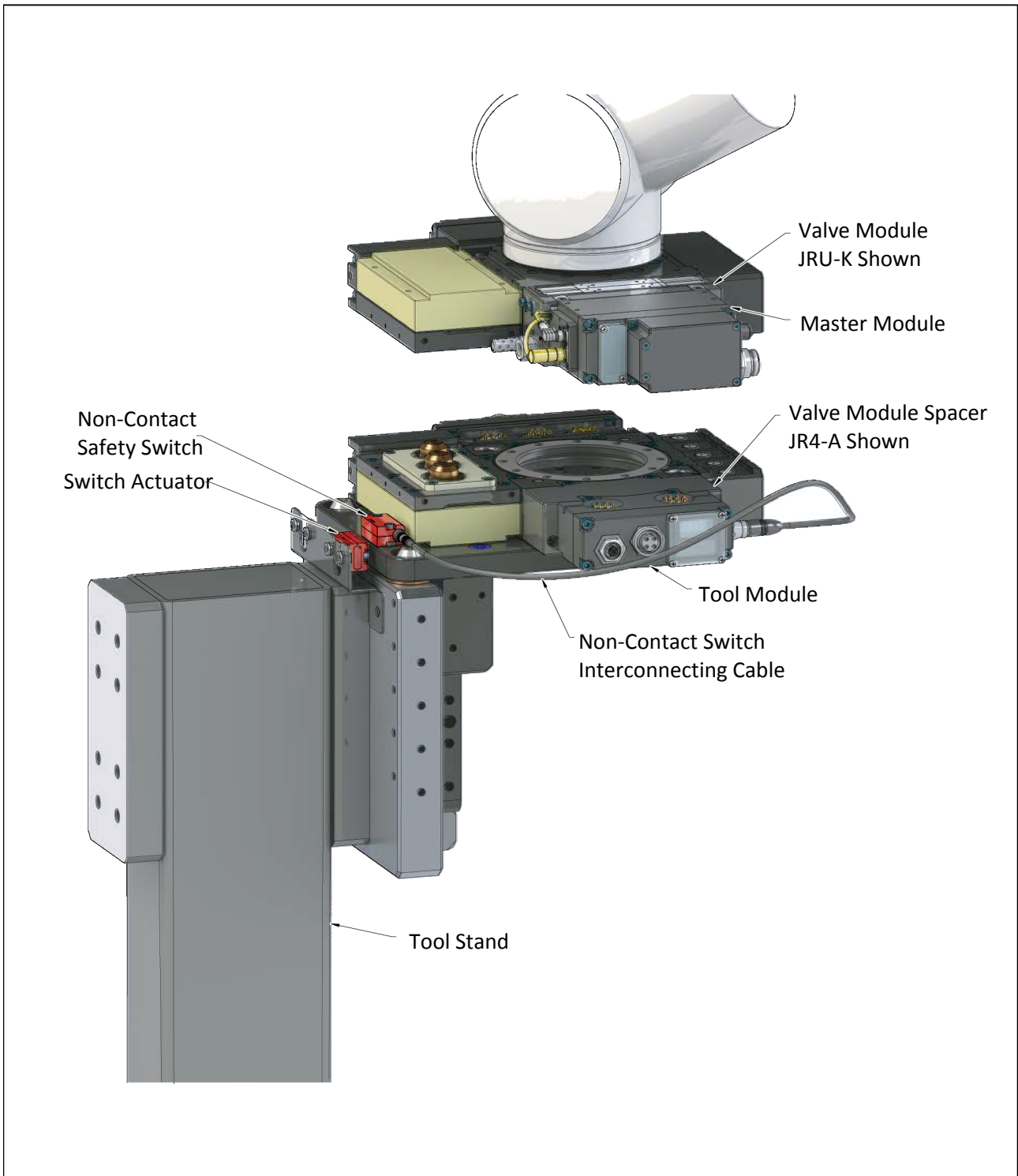

Safety Switch (Modules Shown for Reference Only)

5 Operation

A thorough understanding of the advanced diagnostic and fault reporting capability is required to proficiently operate this product. The following information is provided to help define the behavior of the DL-K/DL-A modules.

5.1 Inputs

The following describes the most critical inputs from the SCHUNK Master module.

Locked	<p>A proximity sensor input indicating that the coupling mechanism is in the Lock position. The “LOCKED” bit in the PROFINET bitmap will only be set high if the following conditions are true:</p> <ul style="list-style-type: none"> • LOCKED sensor input is 1 • UNLOCKED sensor input is 0 • TOOL PRESENT input is 1 • RTL1 and RTL2 inputs are 1
RTL1 and RTL2	<p>Proximity sensor inputs that indicate the tool changer master is close to the tool. It is recommended that these inputs be used to indicate when it is okay to couple the tool changer. These proximity sensors are installed in the Master body and sense targets in the Tool body that indicate the Master is adjacent to the tool (within ~ 0.06” or 1.5mm).</p>
SSO 1 and SSO 2	<p>Discrete inputs from the Euchner safety switch, which are high when the tool changer is in the stand.</p>
Tool Present	<p>An input indicating the master module is electrically connected to the tool.</p>
Unlocked	<p>A proximity sensor input indicating that the coupling mechanism is in the Unlocked position. The bit “UNLOCKED” in the PROFINET bitmap will only be set high if the following conditions are true:</p> <ul style="list-style-type: none"> • UNLOCKED sensor input is high • LOCKED sensor input is low
US1 Power Present	<p>An input indicating the presence of Input and Logic Power (US1) at the SCHUNK master module. US1 power must be between 20.4 and 28.8 otherwise the tool changer will NOT unlatch.</p>
US2 Power Present	<p>An input indicating the presence of Output Power (US2) at the SCHUNK master module. US1 power must be between 20.4 and 28.8 otherwise the tool changer will NOT unlatch.</p>
V1 Relay and V2 Relay	<p>V1 Relay is a normally open relay driven to closure by Channel 1 of the Euchner Safety Switch (SSO1). Similarly, the V2 Relay is driven to closure by Channel 2 of the Euchner Safety Switch (SSO2). Both of these inputs must be high when the Tool Changer is in the tool stand, otherwise the tool changer will NOT unlatch.</p>

EVERYTHING IS OK	This is an overall status bit that indicates if there is an error condition that will block an unlatch request. This bit is high as long as there are no errors.
Tool Power Is On	The Tool Power Is On bit indicates that the Arc Prevention circuit has turned power on to the tool side.
Unlatch Enabled	<p>The Unlatch Enabled bit indicates when the preconditions for unlatching the tool changer have been met. The preconditions include:</p> <ul style="list-style-type: none">• No Errors• US1 and US2 Power within operating range• Air pressure within operating range• UNLOCKED bit is 0• LATCH bit is 0• The Tool is in the tool stand as indicated by SSO1, SSO2, V1RELAY, and V2RELAY bits being 1

5.2 Error Conditions

The following describes the reported error conditions and explains how to reset the condition.

AP2 COMM ERROR	<p>This bit indicates that the two Application Processors in the Master module have stopped communicating.</p> <p>The error condition can be reset with a power cycle.</p>
CROSS MONITORING ERROR	<p>The two Application Processors monitor the various safety-related inputs and outputs. If the processors are not in agreement on the status of these inputs and outputs the CROSS_MONITORING_ERROR bit will be set.</p> <p>The error condition can be reset with a power cycle.</p>
ERROR ON LATCH	<p>This bit indicates that a short circuit or overload condition on the LATCH output has been detected.</p> <p>The error condition can be reset with the “Clear Errors” bit.</p>
ERROR ON UNLATCH1	<p>This bit indicates that a short circuit or overload condition on the UNLATCH output to Valve 1 has been detected.</p> <p>The error condition can be reset with the “Clear Errors” bit.</p>
ERROR ON UNLATCH2	<p>This bit indicates that a short circuit or overload condition on the UNLATCH output to Valve 2 has been detected.</p> <p>The error condition can be reset with a power cycle.</p>
Lock/Unlock Sensor Fault	<p>This error bit will be set if the Locked and Unlocked Sensors are on at the same time. If the condition is not true anymore then the bit shall be reset.</p>
PRESSURE TOO HIGH	<p>The Valve Adapter operating pressure is 4,1 to 6,9 bar. If the module detects that the air pressure is too high then the PRESSURE TOO HIGH bit will be set. The error can be reset with the “Clear Errors” bit or by supplying air at the correct pressure.</p>
PRESSURE TOO LOW	<p>The Valve Adapter operating pressure is 60 to 100 psi. If the module detects that the air pressure is too low then the PRESSURE_TOO_LOW bit will be set.</p> <p>The error can be reset with the “Clear Errors” bit or by supplying air at the correct pressure.</p>
RTL1/RTL2 Mismatch	<p>The DL Control Module shall check for a mismatch of the sensor inputs RTL1 and RTL2 immediately after it receives an UNLATCH command. In case of a mismatch it shall set the “RTL1/RTL2 Mismatch Error” bit. This error bit shall be reset when a new UNLATCH command is received (UNLATCH command removed and reapplied) and the mismatch condition is removed with the “Clear Errors” output bit.</p>
SSFAULT	<p>This error bit indicates that the safety switch has detected a fault condition. This condition is continually monitored and will disable the Unlatch and turn off Unlatch immediately.</p> <p>The error condition can be reset with a power cycle.</p>

TOOL-ID ERROR	<p>The Tool ID shall be available to the Master within 250ms from the time the changer is coupled; otherwise a TOOL-ID ERROR is set in the bit map. If the Master and Tool are coupled and the Tool ID fails to be reported, a TOOL-ID ERROR is set. The error condition can be reset with a rising edge of TOOL PRESENT or power cycle.</p>
UNSAFE LATCH	<p>A LATCH command shall only be performed if the following conditions are true: •</p> <ul style="list-style-type: none">• LATCH command is received• UNLATCH bit is 0• US1 and US2 Power Present is 1• LOCKED sensor input is 0• PRESSURE_TOO_LOW and PRESSURE_TOOL_HIGH are 0• The RTL inputs are 1• SYSTEM_IS_UNSAFE bit is 0 <p>If the LATCH command is received and the above conditions are not all met, the UNSAFE_LATCH error bit shall be set.</p>
UNSAFE UNLATCH	<p>The UNSAFE_UNLATCH bit will be set when the user sends an unsafe unlatch command, refer to Section "Unlatch Enabled" in chapter "Inputs" for safe unlatch conditions. This condition is monitored immediately after UNLATCH command and will disable the Unlatch and turn off Unlatch immediately. If UNLATCH is inadvertently held high during a power cycle the UNSAFE_UNLATCH error will be generated. This error bit will be reset when a new UNLATCH command is received (UNLATCH command removed and reapplied) and the UNLATCH_ENABLE conditions are met or with the rising edge of the "Clear Errors" output bit.</p>
VALVE ERROR	<p>If the module detects an error in the function of either valve, a VALVE_ERROR bit shall be set. Reference the JR4 Valve Adapter Installation and Operation Manual for potential valve failure modes. Valve errors set the SYSTEM_IS_UNSAFE bit so a power cycle is required to clear.</p>
PRESSURE DISCONNECTED	<p>The PRESSURE_DISCONNECTED bit indicates that the pressure sensor is disconnected and/or that there are broken wires in the sensor cable.</p> <p>If the pressure sensor is left disconnected then a SYSTEM_IS_UNSAFE error will be generated. The error condition can be reset with a power cycle.</p>
SYSTEM IS UNSAFE	<p>Any safety-related error (Application Processor communication errors, input/output mismatch errors, safety switch error, valve error, etc.) will set the SYSTEM_IS_UNSAFE error. If the SYSTEM_IS_UNSAFE error bit is set the UNLATCH and LATCH outputs shall be frozen. Refer to following Table for the errors that will trigger a SYSTEM_IS_UNSAFE error.</p>

The error condition can be reset with the Clear Errors bit.

Error Conditions

Error Bit	Error Description	TRIGGERS SYSTEM_IS_UNSAFE ERROR	Reset with
AP2_COMM_ERROR	Communication failure between Application Processor 1 and 2	Yes	Clear Errors Bit
CROSS_MONITORING_ERROR	Application Processor safety-related inputs and outputs do not match	Yes	Clear Errors Bit
ERROR_ON_LATCH	Short circuit detection on LATCH output	No (Yes only during Unlatch)	Clear Errors Bit
ERROR_ON_UNLATCH_H1	Short circuit detection on UNLATCH output to Valve 1.	No (Yes only during Unlatch)	Clear Errors Bit
ERROR_ON_UNLATCH_H2	Short circuit detection on UNLATCH output to Valve 1.	No (Yes only during Unlatch)	Clear Errors Bit
LOCK/UNLOCK Sensor Fault	LOCKED and UNLOCKED Sensor on at the same time	No (Yes only during Unlatch)	Correct error or Clear Errors Bit
PRESSURE_DISCONNECTED	Pressure Sensor not connected	Yes	Clear Errors Bit
PRESSURE_TOO_HIGH	Air supply to Valve Adapter too high	No (Yes only during Unlatch)	Clear Errors Bit
PRESSURE_TOO_LOW	Air supply to Valve Adapter too low	No (Yes only during Unlatch)	Clear Errors Bit
RTL1/RTL2 mismatch	RTL1/RTL2 sensor inputs do not match	No	Rising edge of UNLATCH or Clear Errors Bit
TOOL_ID_ERROR	TOOL-ID timeout error	No	Rising edge of TOOL_PRESENT; Clear Errors Bit
UNSAFE_LATCH	Latch requested under unsafe conditions	No	Rising edge of LATCH or Clear Errors Bit
UNSAFE_UNLATCH	Unlatch requested under unsafe conditions	No	Rising edge of UNLATCH or Clear Errors Bit
VALVE_ERROR	Valve module pressure and/or position error	Yes	Clear Errors Bit

5.3 Recommended Sequence of Operation

1. **Start:** The robot and Tool Changer master are free of the stand or storage location, the Tool Changer is uncoupled and the Tool Changer locking mechanism is fully retracted (unlocked condition). The tool is by itself in the Tool Stand. No error or fault conditions exist.
 - a. The **RTL1** and **RTL2** inputs are 0.
 - b. The **Unlocked** inputs are 1.
 - c. The **Locked** inputs are 0.
 - d. The **SSO_1**, **SSO_2**, **V1RELAY**, and **V2RELAY** inputs are 0.
 - e. The SCHUNK tool and any downstream PROFINET device(s) are offline.
 - f. The **US1_Power_Present (Input Power)** and **US2_Power_Present (output Power)** inputs are true and must remain so at all times.
 - g. **Tool-ID** invalid (all 1: 0xFFFF)
 - h. The **Unlatch** output is false and the **Latch** output is 0.
 - i. **Unlatch Enabled** is 0.
 - j. **Everything is OK** bit is 1.
2. Robot and master move into the tool, are parallel and within 1.5 mm to 3.8 mm of the tool (i.e., the module contact pins are touching, but the **RTL** sensors have not yet sensed the targets on the tool).
3. Robot and master move within 0.06" of the tool and safety switch is within range.
 - a. The **RTL1** and **RTL2** inputs are true, indicating that it is ok to couple the tool.
 - b. The **SSO_1**, **SSO_2**, **V1RELAY**, and **V2RELAY** are true.
 - c. The **Tool Present input** goes true, indicating that the master and tool are in close proximity of each other.
 - d. Communication is initiated with the SCHUNK tool and downstream nodes. When the **Tool Present input** goes true **Tool-ID** becomes available within 100–150ms.
 - e. Shortly thereafter, communications should be established with the downstream devices.
 - f. **Unlatch Enabled** is true.
 - g. **Everything is OK** bit is true.
4. Couple the Tool Changer.
 - a. The **Latch** output is made true.
 - b. The **Unlocked** input goes false a short time later, indicating piston travel. Subsequently, the **Locked** input goes true, indicating that the coupling operation is complete.

- c. Once the **Locked** input goes true, a short time later the **Latch** output is made false.
 - d. Power becomes available on the Tool and the **Tool Power is On** bit becomes true.
 - e. **Unlatch Enabled** is true.
 - f. **Everything is OK** bit is true.
 - g. Robot moves away from the tool stand with the Tool Changer coupled.
 - a. The **Safety Switch** becomes deactivated, and the **SSO_1**, **SSO_2**, **V1RELAY**, and **V2RELAY** inputs go off.
 - b. **Unlatch Enabled** is off.
 - c. **Everything is OK** bit is on.
5. Normal operation
- a. The following inputs are off:
 - I. **Unlocked**
 - II. **SSO_1**
 - III. **SSO_2**
 - IV. **V1RELAY**
 - V. **V2RELAY**
 - VI. **Unlatch Enabled**
 - b. The following inputs are on:
 - I. **Locked**
 - II. **US1 Power (Input Power)**
 - III. **US2 Power (Output Power)**
 - IV. **RTL1 and RTL2**
 - V. **Tool Power is On**
 - VI. **Tool Present**
 - VII. **Everything is OK bit is on.**
 - c. The following outputs are 0:
 - I. **Unlatch**
 - d. The following outputs are 1:
 - I. **Latch**
6. Robot moves into the Tool Stand with the Tool Changer coupled. **Everything is OK** bit is 1.
- a. When the tool is returned to the stand, the **Safety Switch** becomes activated and the **SSO_1**, **SSO_2**, **V1RELAY**, and **V2RELAY** inputs go 1.
 - b. **Unlatch Enabled** becomes 1, indicating that it is safe to uncouple the Tool Changer.

7. Uncouple the Tool Changer.
 - a. The **Unlatch** output is made 1.
 - b. The **Tool Power is On** bit becomes 0.
 - c. Communication is lost with downstream device(s).
 - d. The Locked input goes 0 a short time later and subsequently the **Unlocked** input goes 1, indicating that the uncoupling operation is complete.
 - e. Once the **Unlocked** input goes 1, a short time later the **Unlatch** output is made 0.
 - f. **Unlatch Enabled** is 1.
 - g. **Everything is OK** bit is 1.

8. Robot and master move away from the tool, are parallel and between 0.06" to 0.15" of the tool.
 - a. The **Safety Switch** becomes deactivated, and the **SSO_1**, **SSO_2**, **V1RELAY**, and **V2RELAY** inputs go off.
 - b. **Unlatch Enabled** is off.
 - c. **Everything is OK** bit is on.)

9. Normal operation
 - a. The following inputs are off:
 - I. **Unlatch Enabled**
 - II. **Locked**
 - III. **RTL1 and RTL2**
 - IV. **Tool Present**
 - V. **SSO_1**
 - VI. **SSO_2**
 - VII. **V1RELAY**
 - VIII. **V2RELAY**
 - IX. **Tool Power is On**
 - b. The following inputs are on:
 - I. **Unlocked**
 - II. **US1 Power (Input Power)**
 - III. **US2 Power (Output Power)**
 - IV. **Everything is OK**
 - V. **Tool-ID invalid (all 1 → 0xFFFF)**
 - c. The following outputs are off:
 - I. **Latch**
 - d. The following outputs are on:
 - I. **Unlatch**

5.4 Setting the Tool-ID

Five pushbutton switches are provided on the Tool module for setting of a Tool-ID number. Each Tool must have a unique 5 digit Tool-ID number.

1. Loosen four M3 Pan Head Captive Screws and remove Tool-ID window.

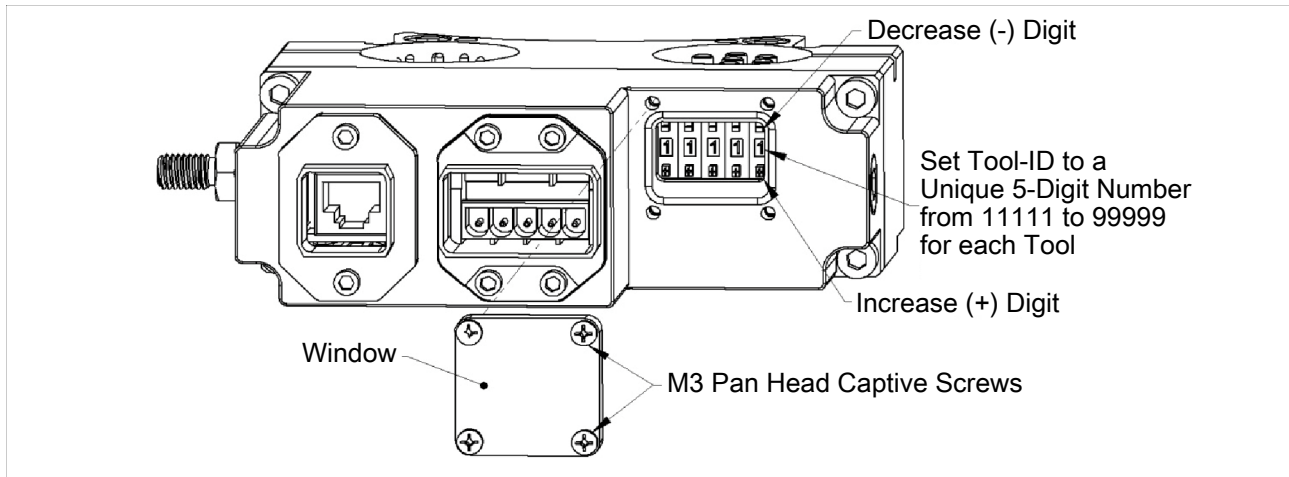

Set Tool-ID

2. Use a non-conductive tool (e.g., plastic stylus) to press on the Tool-ID pushbuttons to increase (+) or decrease (-) the digit value from 0 to 9. Set the Tool-ID to the desired unique five digit number from 00000 to 99999 for each tool.
3. Re-install the Tool-ID window and tighten the M3 Pan Head Captive Screws.

6 Maintenance and care

Once installed the operation of the control modules is generally trouble free. The modules are not designed to be field serviced as all point-to-point wiring connections are soldered. Component replacement is limited to the V-Ring seal on the Master.



⚠ WARNING

Do not perform maintenance or repair on Tool Changer or modules unless the tool is safely supported or docked in the tool stand and all energized circuits (e.g. electrical, air, water, etc.) have been turned off.

Injury or equipment damage can occur with tool not docked and energized circuits on.

- Dock the tool safely in the tool stand and turn off all energized circuits before performing maintenance or repair on Tool Changer or modules.

If the Tool Changer is being used in dirty environments (e.g., welding or deburring applications), care should be taken to limit the exposure of the Tool Changer. Idle Tool assemblies should be covered to prevent debris from settling on the mating surface. Also, the Master assembly should be exposed for only a short period of time during Tool change and down time.

Under normal conditions, no special maintenance is necessary, however it is recommended that periodic inspections be performed to assure long-lasting performance and to assure that unexpected damage has not occurred. Perform the following visual inspection monthly:

1. Inspect mounting fasteners to verify they are tight and if loose, then tighten to the proper torque.
2. Cable connections should be inspected during maintenance periods to ensure they are secure. Loose connections should be cleaned and re-tightened as appropriate. Inspect cable sheathing for damage, repair or replace damaged cabling. Loose connections or damaged cabling are not expected and may indicate improper routing and/or strain relieving.
3. Inspect the Master and Tool pin blocks for any pin damage, debris or darkened pins. Refer to Pin Block Inspection and cleaning.
4. Inspect V-Ring seals for wear, abrasion, and cuts. If worn or damaged, replace. Refer to [Seal Replacement](#) [▶ 46].

6.1 Pin Block Inspection and cleaning

1. For a Tool Changer, if the Tool Changer is installed place the Tool safely in the tool stand. Uncouple the Tool Changer or Utility Coupler to allow clear access to the Master and Tool plates.
2. Turn off and de-energize all energized circuits (e.g. electrical, air, water, etc.).

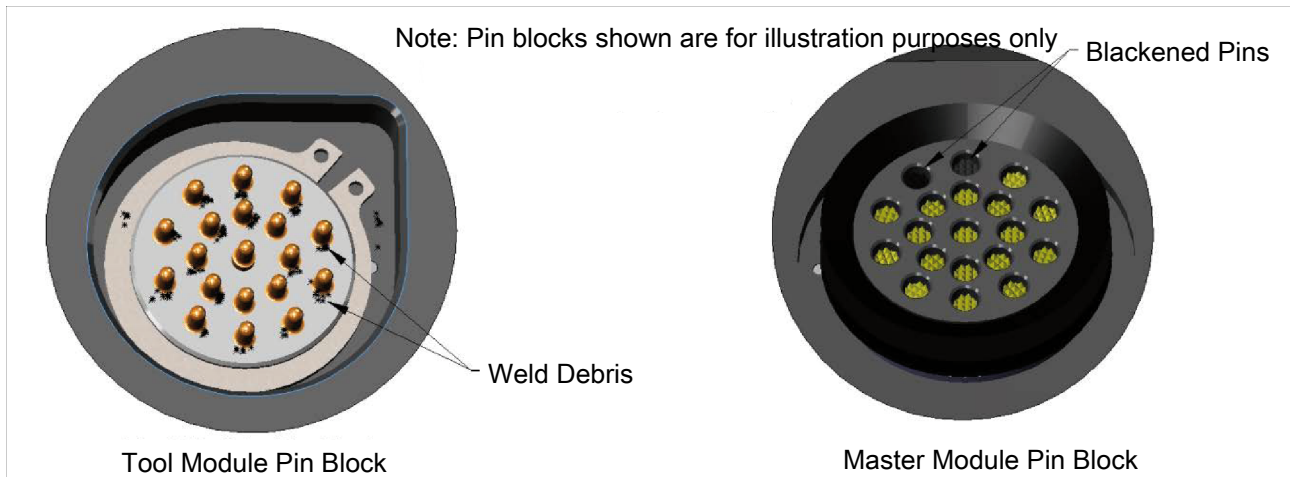

Inspect Master and Tool Pin Blocks

3. Inspect the Master and Tool pin blocks for any debris or darkened pins.

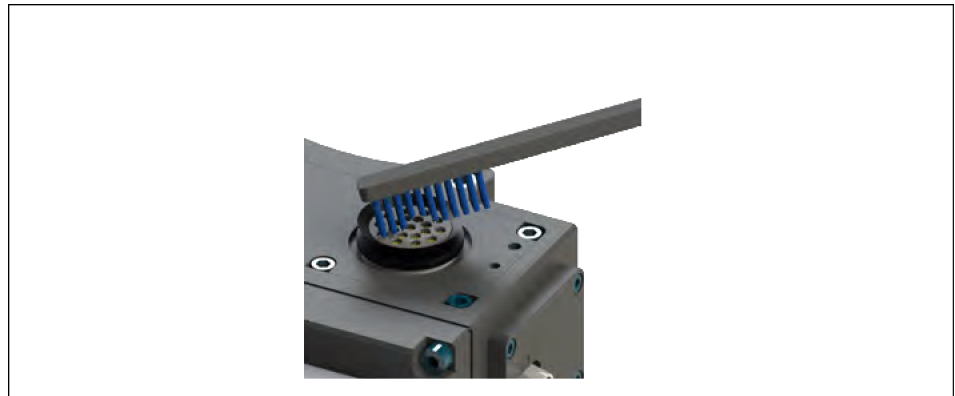

4. If debris or darkened pins exist, remove debris using a vacuum, and clean using a nylon brush.

NOTE

Do not use an abrasive media, cleaners, or solvents to clean the contact pins.

Using abrasive media, cleaners, or solvents will cause erosion to the contact surface.

- Clean contact surfaces with a vacuum or non-abrasive media such as a nylon brush.

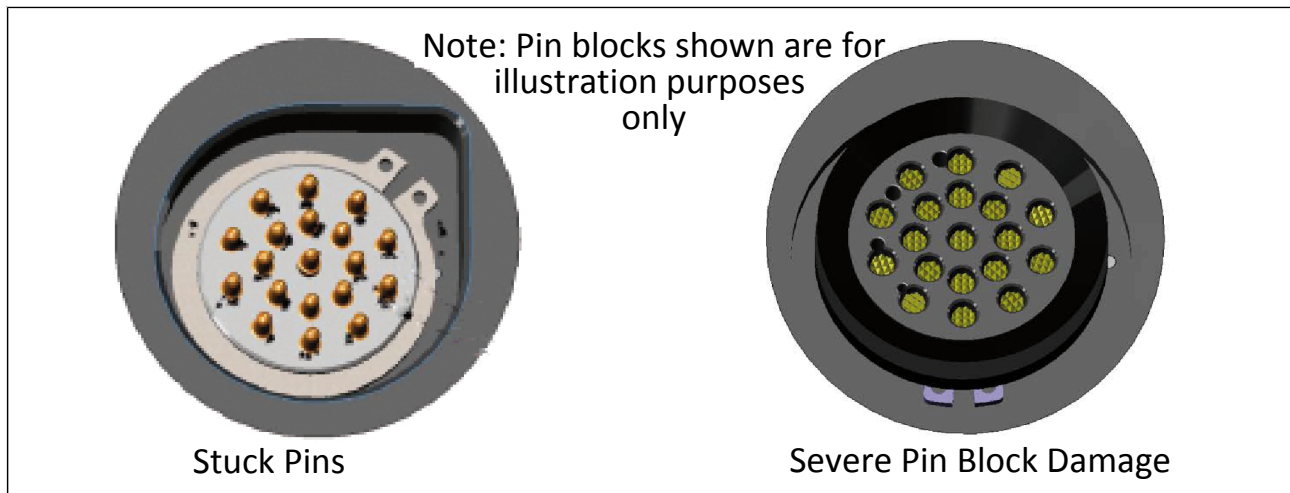

Stuck Pin and Pin Block Damage

5. Inspect the Master and Tool pin blocks for stuck pins or severe pin block damage.
6. If stuck pins or severe pin block damage exists, contact SCHUNK for possible pin replacement procedures or module replacement.
7. If repairs are complete, return circuits to normal operation.

6.2 Seal Replacement

Replace the V-Ring seal:

1. To remove the existing seal, pinch edge of seal with fingers and gently pull the seal away from the pin block on the Master.
2. Pull the seal off the pin block.
3. To install a new seal, stretch the new seal over the shoulder of the pin block.
4. Push the seal's hub down against the pin block using finger tip.

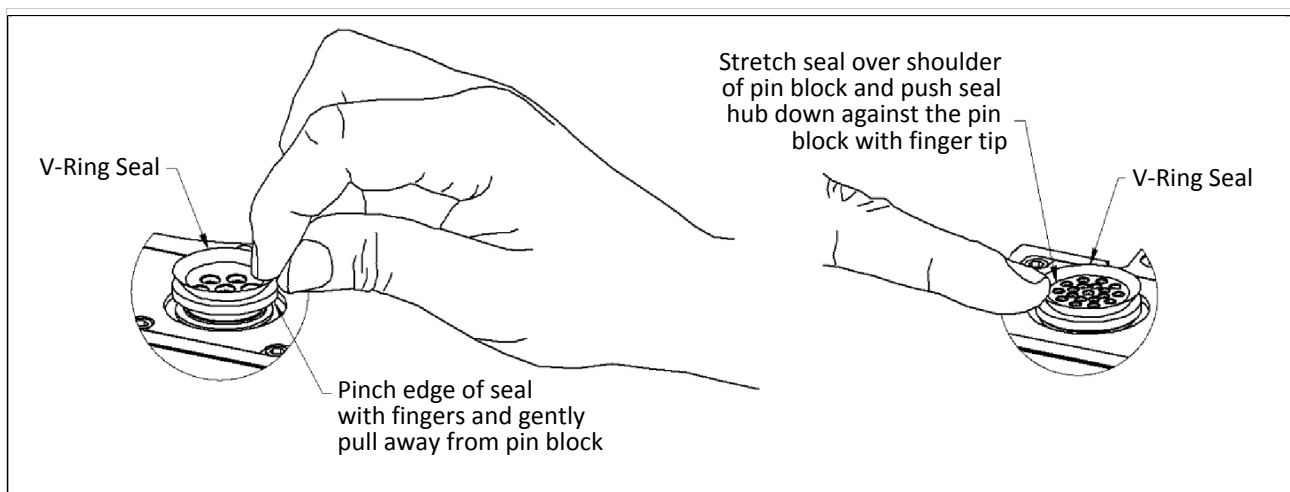

V-Ring seal Replacement

6.3 DL Device Replacement Procedures

The device replacement procedures are based on the following assumptions:

- The topology of the PROFINET network was properly defined with the PROFINET engineering tool.
- The PROFINET controller supports automatic device replacement.

6.3.1 Replace DL module with a new “out-of-the-box” DL module

1. Remove the “old” module from the Tool Changer, refer to Link Montage for removal procedure.
2. Install new module on Tool Changer, refer to Link Montage for installation procedure.

6.3.2 Replace DL5 module with an already-commissioned DL5 module

1. Remove the “old” module from the Tool Changer, refer to for removal procedure.
2. It may be necessary to clean the mounting surface on the JR4 valve adapter prior to installing the module in order to remove any debris that may be present.
3. Using the ledge feature as a guide place the DL5-M Control/Signal Module to the JR4 Valve Adapter mounting surface. Align the control/signal module with the valve adapter using the dowels in the bottom of the ledge feature.
4. If fasteners do not have pre-applied adhesive, apply Loctite 242® to the supplied M6 SHCS fasteners. Install the two M6 socket head screws securing the Control/Signal Module to the Valve Adapter and tighten to 40–70 in-lbs.
5. Connect the pressure sensor and proximity sensor cables to the connectors on the DL5-M Module.
6. Connect the Euchner Safety switch cable to the connector on the DL5-M Module.
7. Connect the RTL1, RTL2, Lock, and Unlock sensor cables to the connectors on the DL5-M Module.
8. Connect the 5-Pin Power cable to the connectors on the DL5-M Module.

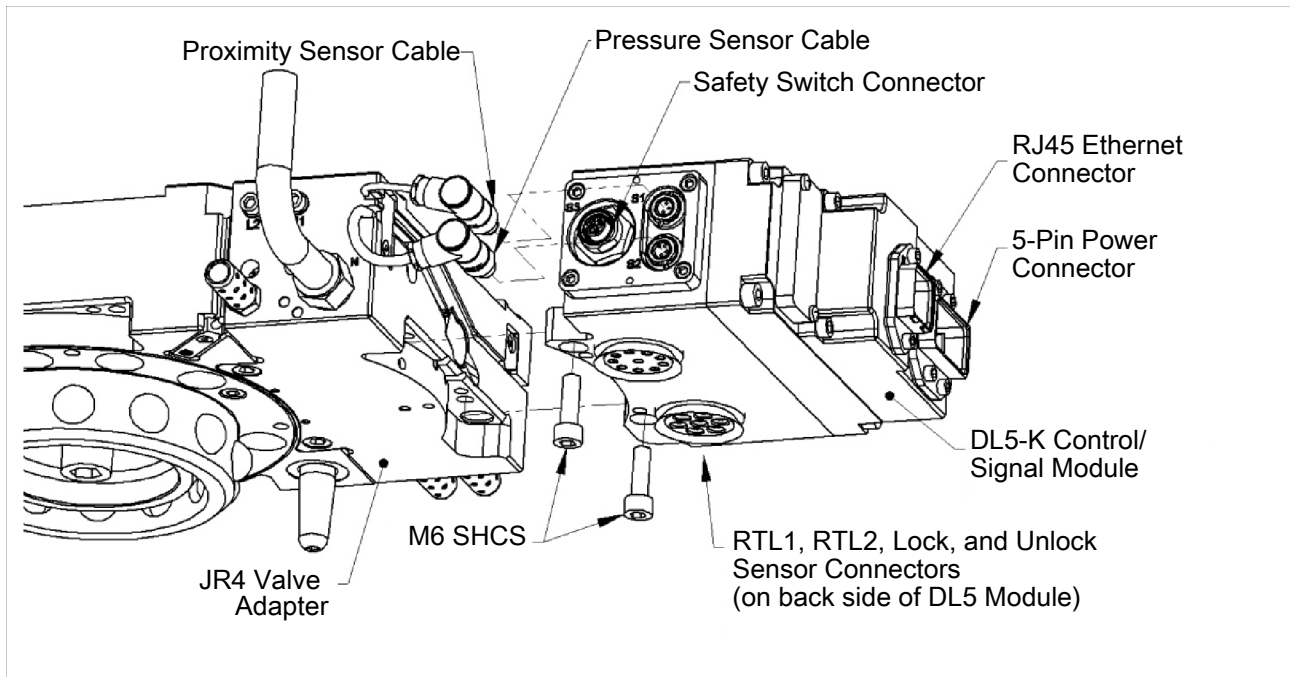

Module Installation and Removal DL5-M Control/Signal Module

9. Loosen two M3 Pan Head Captive Screws and remove LED window.
10. Locate Reset Button between BF and E2 LED.
11. Use a non-conductive tool (e.g. plastic stylus) to press on the Reset Button -> the SF LED will change from GREEN to blinking RED, indicating that the DL6 module will clear its name and IP address after the next power-cycle.

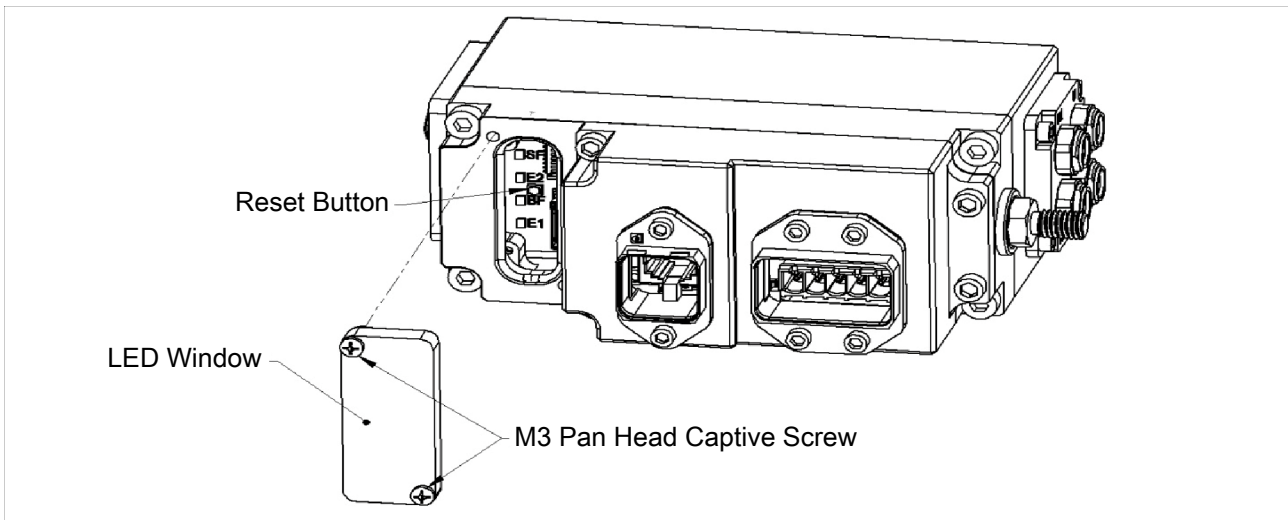

Reset Button

12. Re-install the LED window and tighten the M3 Pan Head Captive Screws.
13. Disconnect the 5-Pin Power cable to the connectors on the DL5-M Module.
14. Connect the RJ45 Ethernet cable and the 5-Pin Power cable to the connectors on the DL5-M Module.
15. The “new” module will automatically get the name and IP address of the old module assigned.
16. After a few seconds it should be operating on the network.
17. The SF LED should be GREEN.

7 Trouble shooting

Refer to table below for troubleshooting information:

Symptom	Possible Cause / Correction
Unit will not lock or unlock	<p>Verify that ball bearings are moving freely. Clean and lubricate as needed (see Tool Changer Manual Maintenance Section).</p> <p>Check air supply, pressure must be between 4,2 und 6,9 psi to operate.</p> <p>Check that exhaust port is properly vented (check muffler).</p> <p>If unlocking, Unlatch Enabled bit is high.</p> <p>Verify that the PROFINET network is operating and communicating properly.</p> <p>Verify that the US1 and US2 Power present bit is HIGH.</p> <p>Verify that the Master and Tool are within the specified No-Touch zone when attempting to lock.</p> <p>Everything is OK bit is high.</p> <p>Verify that when the tool is in the stand the SSO1 and SSO2 inputs are high.</p> <p>Verify that the Safety switch is functioning and properly adjusted.</p> <p>Verify that the valve is operating properly.</p>
Sensors not operating properly (but PROFINET is operating correctly)	<p>Verify that cables are connected correctly (Refer to the Tool Changer Manual).</p> <p>Ensure that the Tool Plate is securely held to the Master Plate and that nothing is trapped between their surfaces, and that there is no air trapped in the Unlock (U) air port.</p>
Loss of PROFINET Communication	<p>Check/Replace PROFINET cabling up-stream and down-stream of Tool Changer modules.</p> <p>Inspect PROFINET Module contact pins for debris/wear.</p> <p>Verify that the US1 Power Present is connected and available (US1 Power Present and US2 Power Present bits are HIGH).</p>
No Power on the Tool-side	<p>Verify that the Latch command has been issued by the robot.</p> <p>Verify that the Tool Power is On bit is HIGH.</p> <p>Verify that the Tool Present bit is HIGH.</p>
Loss of Auxiliary Power on the Tool-side	<p>Loss of US1 (Logic) power on the Master-side will cause loss of US2 (Auxiliary) power to the Tool. The Arc Prevention Circuit relies on US1 power to operate.</p> <p>Restore US1 power to the Master to restore US2 power to the Tool.</p>

8 Recommended Spare Parts

Description	Part Number
DL5 Master Module Assembly	9121-DL5-M
DL5 Tool Module Assembly	9121-DL5-T
Safety Switch Cables	TBD (1 Meter)
	TBD (2 Meter)
	TBD (4 Meter)

See [Drawings](#) [▶ 52] for spare parts directly associated with the DL5-M/DL5-T modules.

9 Drawings

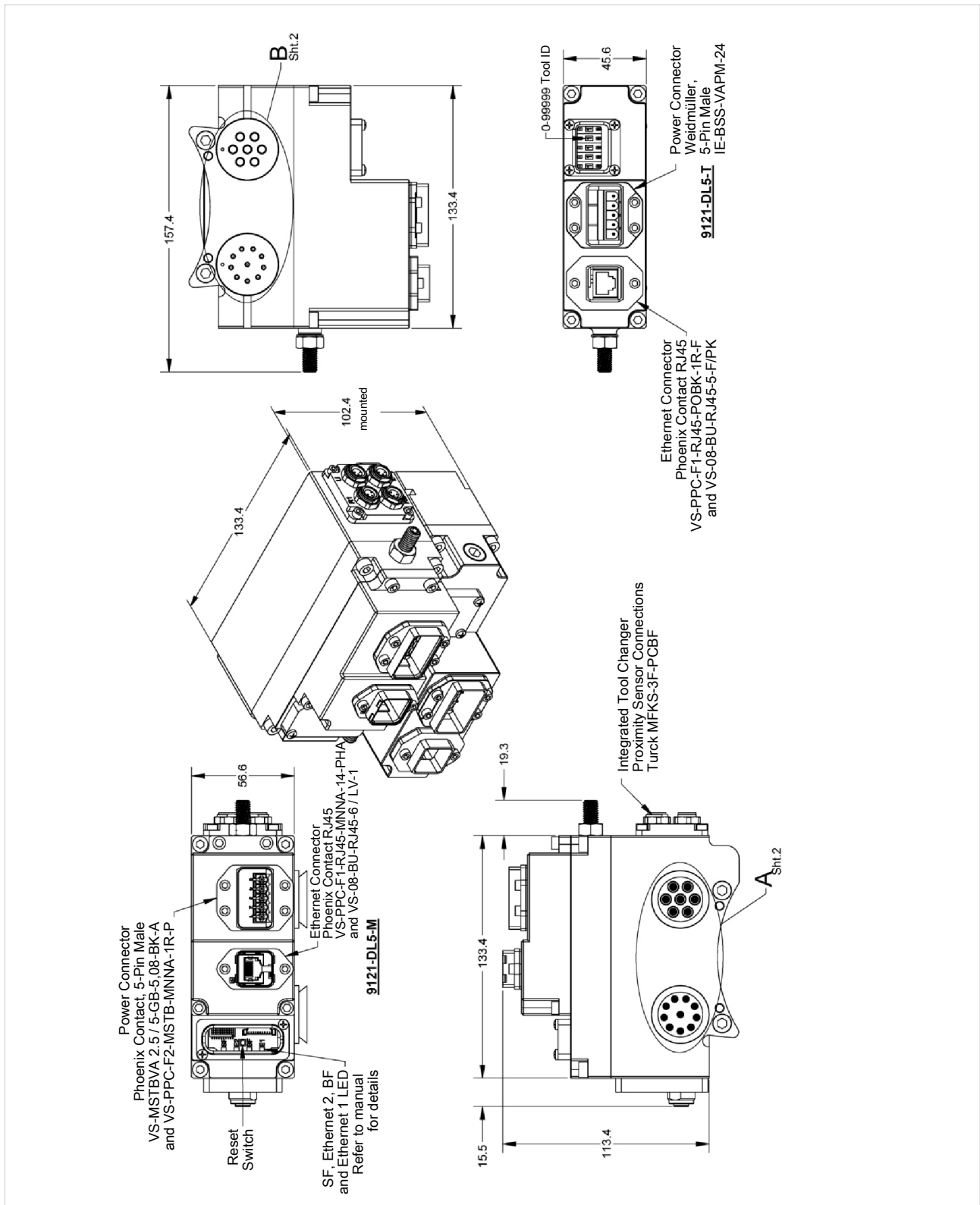

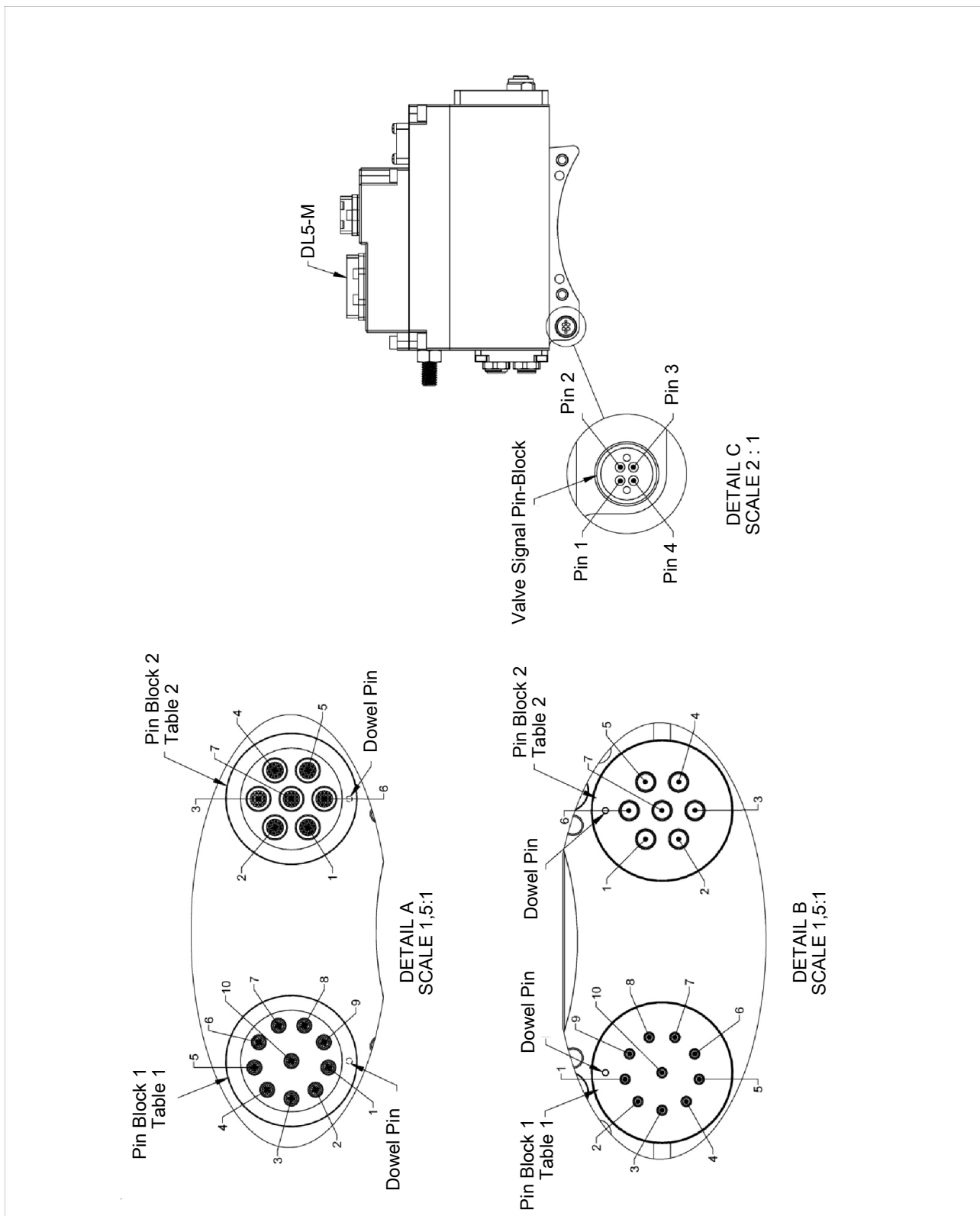

Table 1	
Pin-Block 1	
1	RX1+
2	RX1-
3	RS485+

Table 1	
4	RS485-
5	N/C
6	N/C
7	TX1+
8	TX1-
9	24V_GND
10	24V_TH

Table 2	
Pin-Block 2	
1	AP_US1+
2	TOOL_PRESENT
3	US1-
4	US2-
5	FE
6	AP_US2+
7	24V_TH

Table 3	
Internal Valve Connection	
Stift 1	Latch
Stift 2	Unlatch 2
Stift 3	Unlatch 1
Stift 4	US2-

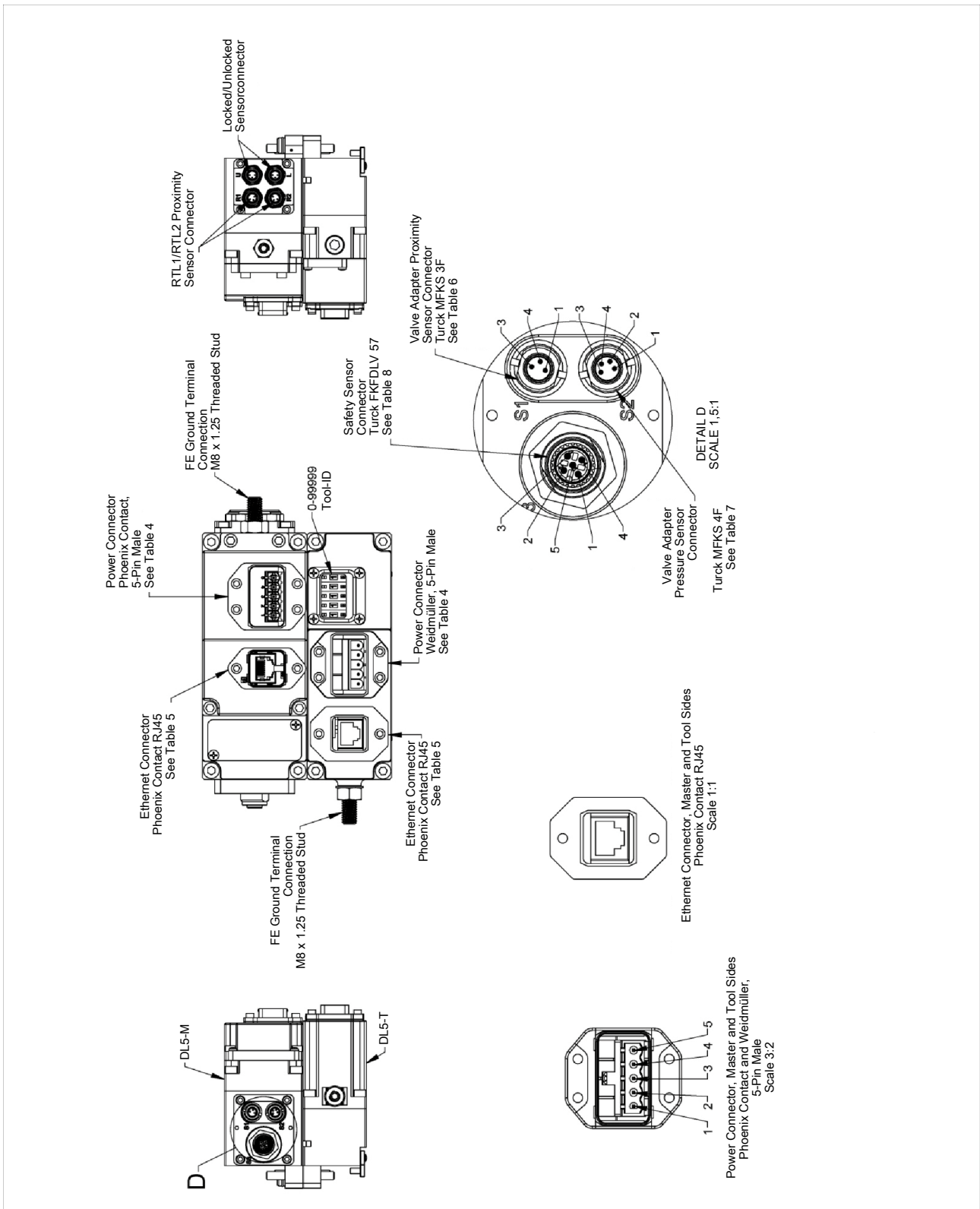

Table 4	
Power Connector	
1	US1 + (L1)
2	US1- (N1)
3	US2+ (L2)

Table 4	
4	US2- (N2)
5	FE

Table 5	
Profinet Connector	
1	TX1+
2	TX1-
3	RX1+
4	RJ45_4
5	RJ45_5
6	Rx1-
7	RJ45_7
8	RJ45_8

Table 6	
Valve Adapter Proximity Sensor	
1	US1+
3	US1-
4	Input

Table 7	
Valve Adapter Pressure Sensor Connector	
1	+5V
2	Pressure Output+
3	Pressure Output-
4	GND_5V

Table 8	
Safety Switch Connector	
1	US1+
2	SSO1
3	US1-
4	SSO2
5	SSFAULT

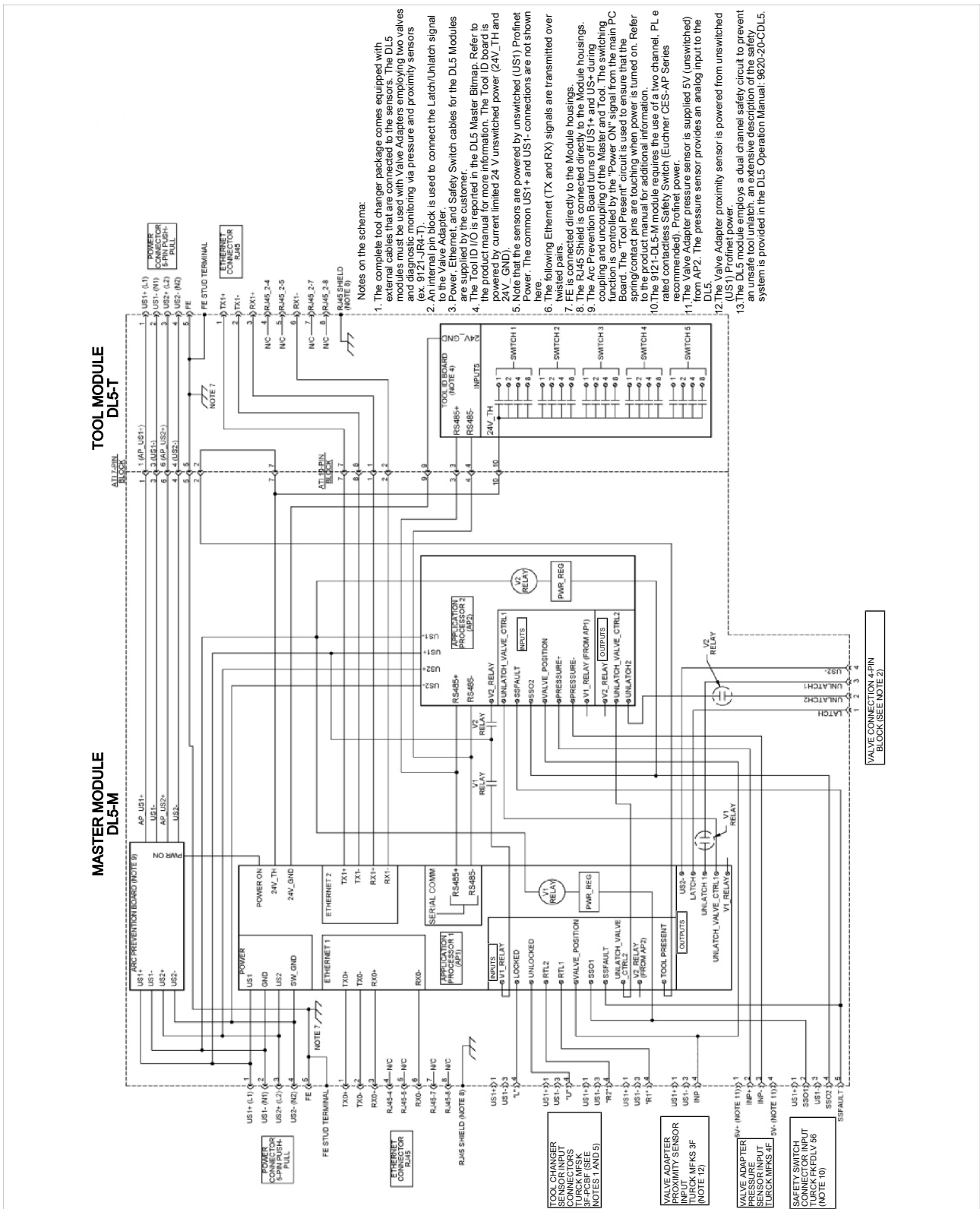

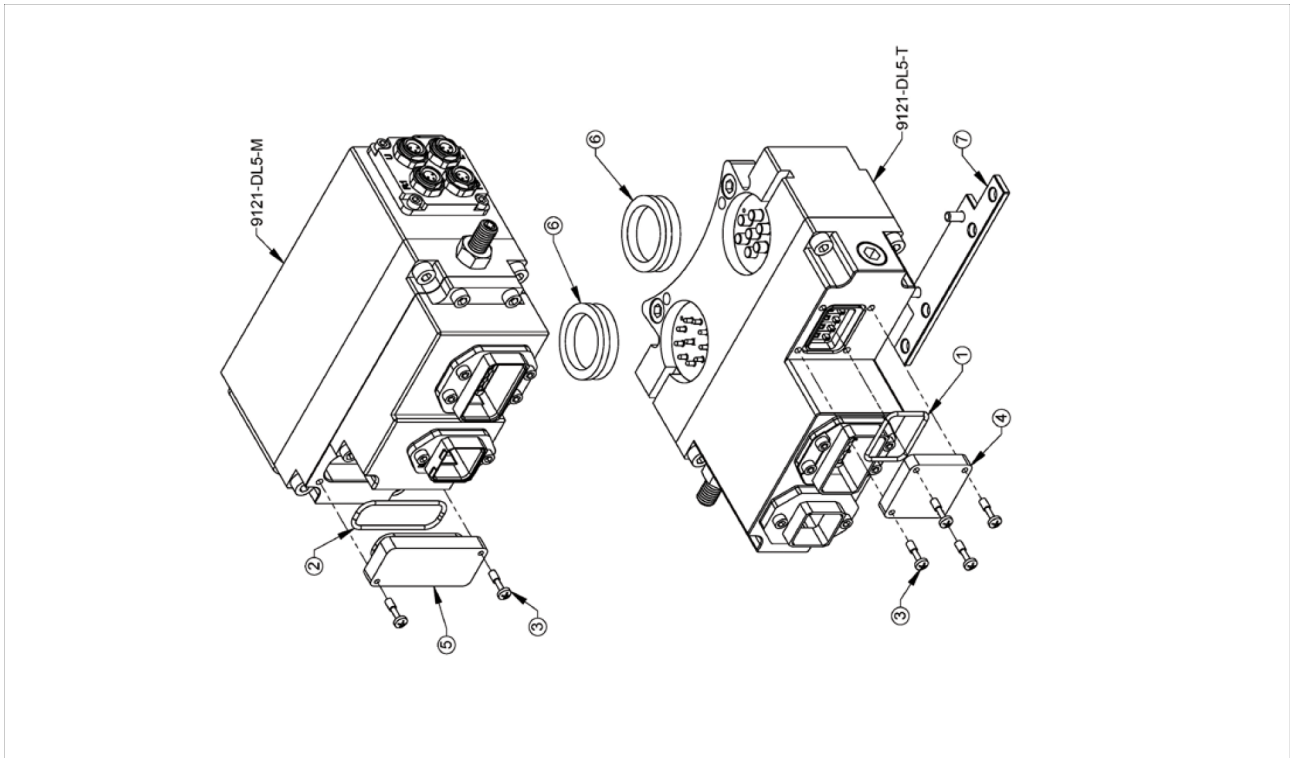

9121-DL5-M/T SERVICEABLE PARTS			
ITEM	QTY	PART NUMBER	DESCRIPTION
1	1	3410-0001091-01	O-ring, AS568-019
2	1	3410-0001201-01	O-ring, AS568-024
3	6	3500-9957012-21	Pan Head M3 Captive Screw M3 X 12
4	1	3700-20-5844	Tool ID Window
5	1	3700-20-4820	Window, DJ Master, Annular Seal
6	1	9948851 / 4010-0000030-01	V-Ring Seal V-22A Nitrile
7	1	9005-20-1199	Tool Cleat Sub-Assembly

Glossary

Application Processor 1

A board inside the DL12 module which controls solenoid outputs, monitors function of the unlatch valves for pressure and position, safety checking and diagnostics, reports sensor status, protects outputs against short circuit overload, detects and reports status of the 24 V power supply, and provides cross monitoring of the pressure processor board.

Application Processor 2

A board inside the DL module which controls Unlatch Valve 2, reports the pressure inside the valve module, and provides cross monitoring of the Application Processor 1.

BF LED

BUS Failure LED; this is a standard Profibus status LED, similar to the DeviceNet Network Status LED.

Clear Errors

An output supplied to the SCHUNK master DeviceNet node to clear all applicable error conditions

EOAT

End Of Arm Tool (end effector).

Error on Latch Output

An input indicating a short circuit overload condition exists with the Latch Output.

Error on Unlatch Output

An input indicating a short circuit overload condition exists with the Unlatch Output.

Ethernet Network Switch

Ethernet network switches are electronic devices that connect multiple Ethernet cables to an Ethernet network while directing the flow of traffic.

Latch (Lock)

The output supplied to the SCHUNK Master module to couple the Tool Changer.

Lock/Unlock Sensor Fault

An input indicating that the Locked and Unlocked inputs are high at the same time.

Locked

A proximity sensor input indicating that the coupling mechanism is in the Locked position.

RTL (Ready To Lock)

A proximity sensor input that senses when the SCHUNK Tool is in close proximity.

SF LED

System Failure LED; this is a standard Profibus status LED, similar to the DeviceNet Module Status LED; it has a red part and a green part.

SSO1 and SSO2

Inputs from a safety switch, which are high when the tool changer is in the stand.

Tool Power is On

The "Tool Power is ON" bit is set high when the Arc Prevention Circuit has activated power on the tool side. If this

bit is low there will be neither Input/ Logic Power nor Output power available on the tool.

Tool Present

A hard connect input (sourced from the Tool) indicating the Master and Tool are electrically connected to each other.

Tool-ID

An input from the Master node reporting the values from the Tool-ID switch on the Tool module.

Unlatch Enable

Indicates it is safe to proceed with an unlatch request.

Unlocked

A proximity sensor input indicating that the coupling mechanism is in the Unlocked position.

Unsafe Unlatch

An input indicating that an Unlatch command was received which would result in an unsafe tool release and was therefore not processed.

US1 Power Present

An input indicating the presence of Input and Logic Power (US1) at the SCHUNK master module.

US2 Power Present

An input indicating the presence of Output Power (US2) at the SCHUNK master module.

V1Relay and V2Relay

Inputs from relays which should mirror the status of SSO1 and SSO2.



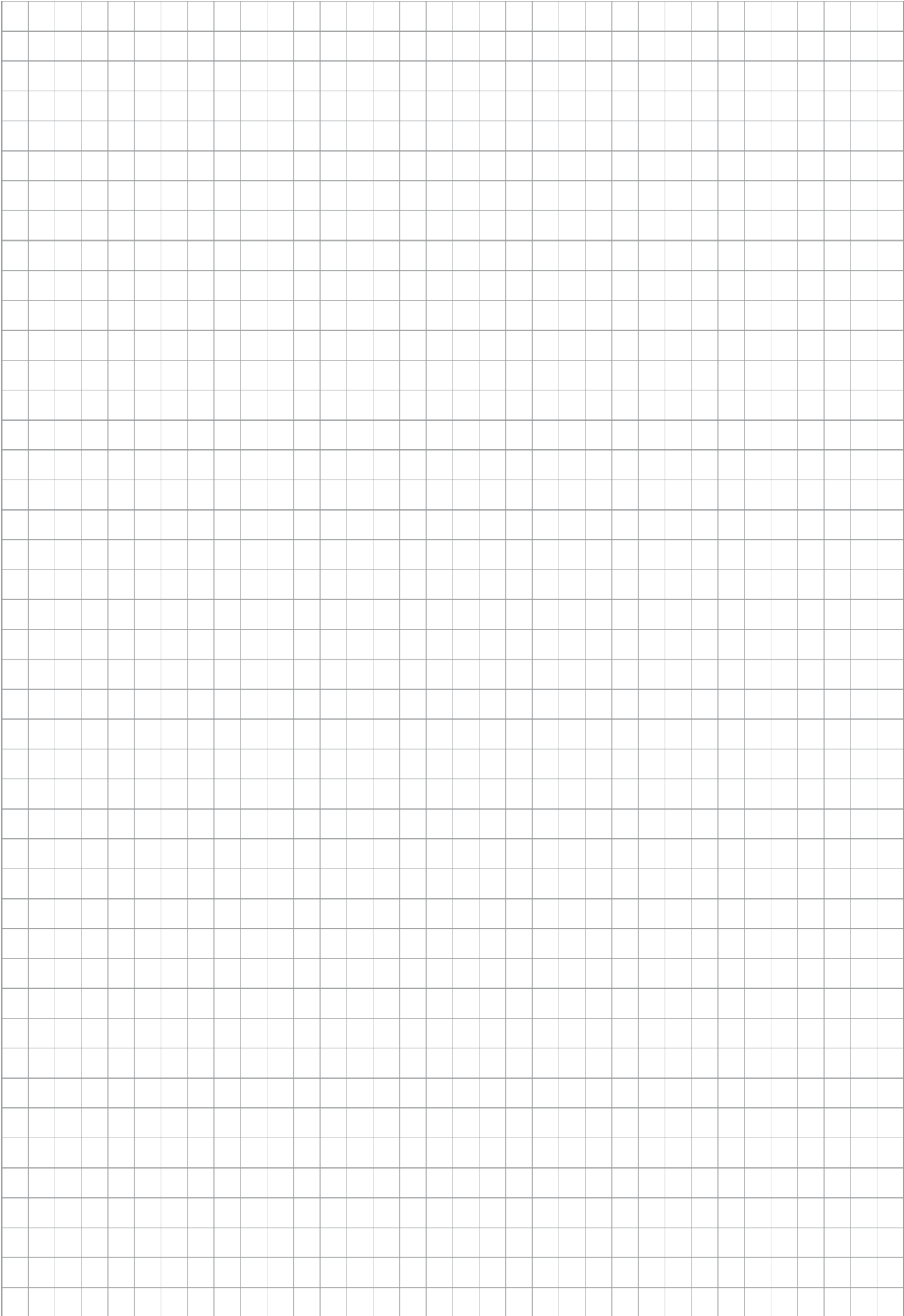

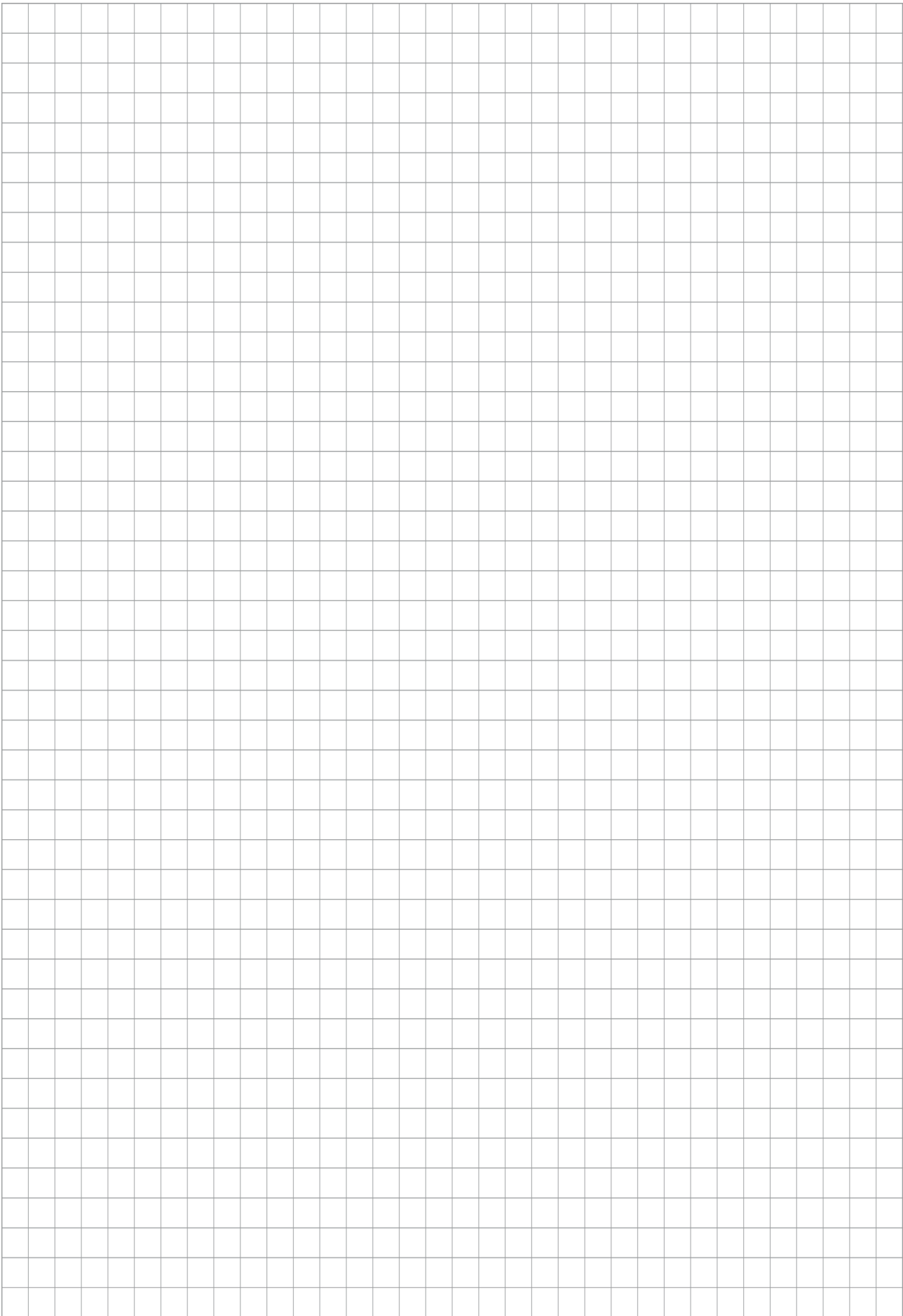

SCHUNK GmbH & Co. KG
Clamping and gripping technology

Bahnhofstr. 106 - 134
D-74348 Lauffen/Neckar
Tel. +49-7133-103-0
Fax +49-7133-103-2399
info@de.schunk.com
schunk.com

Folgen Sie uns | *Follow us*

