

Valve box for gripper actuation PGN+ 64-100

Assembly and Operating Manual



Imprint

Copyright:

This manual remains the copyrighted property of SCHUNK GmbH & Co. KG. It is solely supplied to our customers and operators of our products and forms part of the product. This documentation may not be duplicated or made accessible to third parties, in particular competitive companies, without our prior permission.

Technical changes:

We reserve the right to make alterations for the purpose of technical improvement.

Document number: GAS 380373

Edition: 01.00 | 06/05/2015 | en

© SCHUNK GmbH & Co. KG

All rights reserved.

Dear customer,

congratulations on choosing a SCHUNK product. By choosing SCHUNK, you have opted for the highest precision, top quality and best service.

You are going to increase the process reliability of your production and achieve best machining results – to the customer's complete satisfaction.

SCHUNK products are inspiring.

Our detailed assembly and operation manual will support you.

Do you have further questions? You may contact us at any time – even after purchase.

Kindest Regards

Your SCHUNK Electronic Solutions GmbH

Am Tannwald 17

D-78112 St. Georgen

Tel. +49-7725-9166-0

Fax +49-7725-9166-5055

electronic-solutions@de.schunk.com

www.schunk.com



Reg. No. 003496 QM08



Reg. No. 003496 QM08

Table of contents

1	About this manual	4
1.1	Warnings.....	4
1.2	Applicable documents	5
2	Basic safety notes	6
2.1	Intended use.....	6
2.2	Not intended use	6
2.3	Ambient conditions and operating conditions.....	7
2.4	Product safety.....	7
2.4.1	Protective equipment	7
2.4.2	Constructional changes, attachments, or modifications.....	7
2.5	Personnel qualification.....	7
2.6	Using personal protective equipment.....	8
2.7	Notes on particular risks.....	8
3	Warranty	9
4	Scope of delivery	10
5	Accessories	10
6	Technical data	11
6.1	Basic data.....	11
7	Design and description	13
7.1	Design	13
7.2	Description	13
7.3	Electrical and pneumatic block diagram	15
8	Assembly	16
8.1	Mechanical connection	16
8.2	Assembly options	17
8.3	Air connections.....	18
8.4	Electrical connection	19
8.5	Operating display and connector assignment	20
9	Troubleshooting	21
9.1	Operating voltage display or operating displays do not light up.....	21
9.2	Valves switch but gripper does not move	21
9.3	Leakage.....	22
10	Maintenance and care	23
11	Declaration of incorporation	24
12	Appendix on Declaration of Incorporation, as per 2006/42/EC, annex II B	25





1 About this manual

This instruction is an integral part of the product and contains important information for a safe and proper assembly, commissioning, operation, maintenance and help for easier trouble shooting.

Before using the product, read and note the instructions, especially the chapter "Basic safety notes".

1.1 Warnings

To make risks clear, the following signal words and symbols are used for safety notes.

	⚠ DANGER Danger for persons. Non-compliance will inevitably cause irreversible injury or death.
	⚠ WARNING Dangers for persons. Ignoring a safety note like this can lead to irreversible injury and even death.
	⚠ CAUTION Dangers for persons. Non-observance can cause minor injuries.
	NOTICE Material damage Information about avoiding material damage.

1.2 Applicable documents

- General terms and conditions
- Catalog data sheet for purchased product
- Assembly and operating manual for gripper used
- Brief introduction to valve box

The documents listed here, can be downloaded on our homepage
www.schunk.com

2 Basic safety notes

2.1 Intended use

The PGN+ valve box is intended for use as a pneumatic controller of the associated PGN+ gripper. It can also be used for PGB, JGP and DPG+ grippers.

The unit consisting of valve box and gripper is intended for installation in a machine. The requirements of the applicable guidelines must be observed and complied with.

The valve box is not a safety component as defined by the EC Machine Directive 2006/42/EC and must not be used in safety-relevant parts of machine control units.

The product may be used only in the context of its defined application parameters.

The product is designed for industrial use.

To use this unit as intended, it is also essential to observe the technical data and installation and operation notes in this manual and to comply with the maintenance intervals.

2.2 Not intended use

A usage not according to the intended use exists:

- If the product is used for a purpose other than that described in the chapter “Intended use”, ([👉 2.1, Page 6](#)).

2.3 Ambient conditions and operating conditions

- Make sure, that the product may be used only in the context of its defined application parameters ([👉 6, Page 11](#)).
- Make sure that the environment is clean and the ambient temperature corresponds to the specifications per the catalog.
- Make sure that the environment is free from splash water and vapors as well as from abrasion or processing dust. Exceptions are products that are designed especially for contaminated environments.

2.4 Product safety

Dangers arise from the product, if:

- the product is not used in accordance with its intended purpose.
- the product is not installed or maintained properly.
- the safety and installation notes are not observed.

Avoid any manner of working that may interfere with the function and operational safety of the product.

Wear protective equipment.

NOTE

More information are contained in the relevant chapters.

2.4.1 Protective equipment

Provide protective equipment per EC Machinery Directive.

2.4.2 Constructional changes, attachments, or modifications

Additional drill holes, threads, or attachments that are not offered as accessories by SCHUNK may be attached only with permission of SCHUNK.

2.5 Personnel qualification

The assembly, initial commissioning, maintenance, and repair of the product may be performed only by trained specialist personnel. Every person called upon by the operator to work on the product must have read and understood the complete assembly and operating manual, especially the chapter "Basic safety notes"

[\(☞ 2, Page 6\)](#). This applies particularly to personnel only used occasionally, such as maintenance personnel.

2.6 Using personal protective equipment

When using this product, observe the relevant industrial safety regulations and use the personal protective equipment (PPE) required!

- Use protective gloves, safety shoes and safety goggles..
- Observe safe distances.

2.7 Notes on particular risks

Risk of injury from objects falling and being ejected

- Provide protective equipment to prevent objects from falling or being ejected, such as processed workpieces, tools, chips, fragments, rejects.
- Check whether all screw connections are tight prior to the start-up or restart.

Risk of injury due to unexpected movements of the machine/automated system

- Switch off the energy supply when performing any work on the valve box.
- Switch off the operating voltage and supply pressure.
- Do not move parts by hand when the energy supply is connected.

3 Warranty

If the product is used as intended, the warranty is valid for 24 months from the date of delivery from the production facility under the following conditions:

- Observance of the ambient conditions and operating conditions
Link Umgebungs- und Einsatzbedingungen

Parts touching the work piece and wearing parts are not part of the warranty.

4 Scope of delivery

- Valve box for gripper actuation PGN+ in the ordered model.
- Accessory pack (Blind plugs, sealing rings, centering sleeves)
- Brief introduction with declaration of incorporation

5 Accessories

The following accessories that are required for the module must be ordered separately:

- M8 connection cable (one M8 connection cable is required for each valve box)

Schunk ID	Article description
0309570	M8x1 sensor cable, 4-pin straight, 2 m
0309571	M8x1 sensor cable, 4-pin straight, 5 m
0309572	M8x1 sensor cable, 4-pin straight, 10 m
0309573	M8x1 sensor cable, 4-pin angled, 5 m
0309574	M8x1 sensor cable, 4-pin angled, 10 m
0309575	M8x1 sensor cable, 4-pin angled, 15 m
0309576	M8x1 sensor cable, 4-pin angled, 20 m

- For additional accessories, see catalog.

6 Technical data

6.1 Basic data

More technical data are included in the catalog data sheet. Whichever is the latest version.

Size	64	100
Mechanical operating data		
Weight [g]	220	300
Dimensions [mm]	65x47x36	95 x50 x30
Protection class when installed	IP 50	IP 50
Control valves	2 x MV 25 valves	2 x MV 25 valves
Ambient temperature		
Min. [°C]	5	5
Max. [°C]	55	55
Gripper actuating time	Switching signal -> end of movement	Switching signal -> end of movement
Guide value at P = 6 bar and Tu = 20°C		
Open [ms]	30	95
Close [ms]	35	130

Size	64	100
Electrical operating data		
Rated voltage [VDC]	24±10%	24±10%
Rated current [A]	0.10	0.10
Max. current [A]	0.25	0.25
Connecting plug	M8, 4-pin	M8, 4-pin
Power consumption per valve		
Switch-on phase 0 to 15 ms [W]	6.0	6.0
Power drop after 15 ms [W]	2.5	2.5
Input impedance [kΩ]	6.8	6.8
Min. on time [ms]	>20	>20

Size	64	100
Pneumatic operating data		
Pressure medium	Filtered compressed air, 40µm, dry, oil-free, compressed air quality as per ISO 8573-1: 6 4 2	
Minimum pressure P [bar]	2	2
Maximum pressure P [bar]	8	8
Function	3/2 directional control valve connection A, open connection B, close	3/2 directional control valve connection A, open connection B, close
Actuation	Valve A/B individually Optional push-pull operation via valve B	Valve A/B individually Optional push-pull operation via valve B
Supply	M5 threaded hole P at the side 2 x M3 threaded hole Pa / Pb	M5 threaded hole P at the side 2 x M3 threaded hole Pa / Pb
Outlets	Gripper direct connections a / b	Gripper direct connections a / b
Total leakage at P=6 bar [Nml/min]	16	16
Sealing material	Viton - incompatible with hot water, steam, amines, organic acids and polar solvents	

7 Design and description

7.1 Design

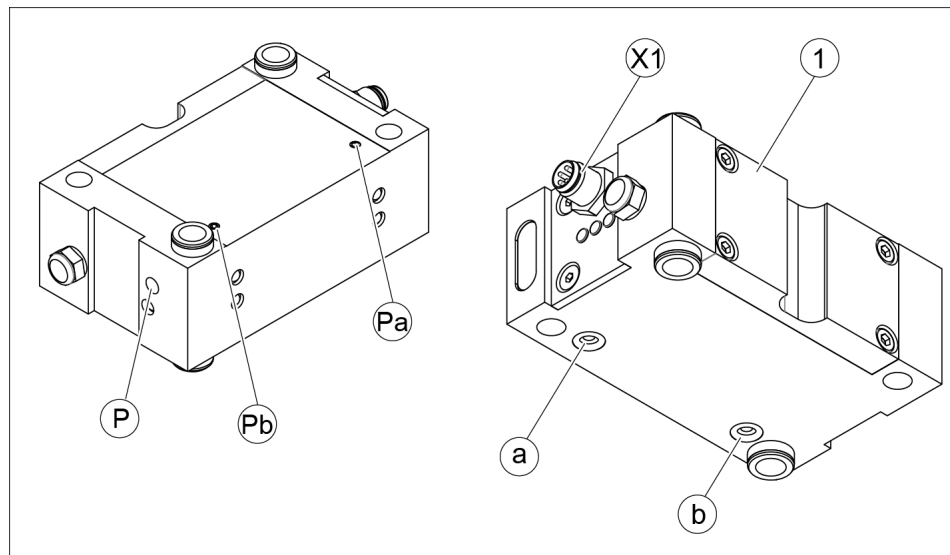

Design

1	Valve box	P	Supply pressure connection
X1	Connection plug for power and actuation signals	Pa	Direct air connection
a	Outlet for gripper connection A	Pb	Direct air connection
b	Outlet for gripper connection b		

7.2 Description

The valve box is used to actuate a pneumatic gripper. Compared to valves attached directly to the gripper by means of swivel fittings (ABV add-on valves), the valve box offers the following benefits:

- Compact design and smaller interfering contour
- Reduced power enables ambient temperature of up to 55 °C
- Faster switching thanks to integrated electronics
- Actuation without power via fieldbus distributor
- Easy air connection
- Option of direct air supply via adapter plate avoids air hoses
- Actuation and energy supply in one shared cable

- Specified actuating times when combined with the gripper
- Optional push-pull actuation using just one control signal

Operation principle

The supply air is routed to the 2 switching valves in the housing for the valve box. Compressed air is connected through to gripper connection A by switching valve A. The gripper opens. Valve B is switched off at this point and vents gripper connection B.

If the valves are actuated the other way round, gripper connection B is supplied with compressed air and gripper connection A vents. The gripper closes.

The actuation signals from the M8 connection plug are routed to control electronics. Changing the level to values between 4 V and 26 V actuates the relevant valve for 15 ms with the energizing current. The current is then lowered to the holding current to reduce losses in the valve coil.

If the actuation signal changes to a level below 2 V, the polarity of the voltage at the valve coil is reversed until the magnetic energy in the coil is transformed into heat. This causes the valve to be switched off more quickly than if the coil were connected with a recovery diode.

With the optional push-pull actuation via control signal B, control signal A is generated internally by inverting control signal B. The status of valve actuation and the supply voltage are displayed visually.

The exhaust air connections for the valves lead outward and are equipped with a sound absorber which can also be replaced by an exhaust air throttle if necessary.

7.3 Electrical and pneumatic block diagram

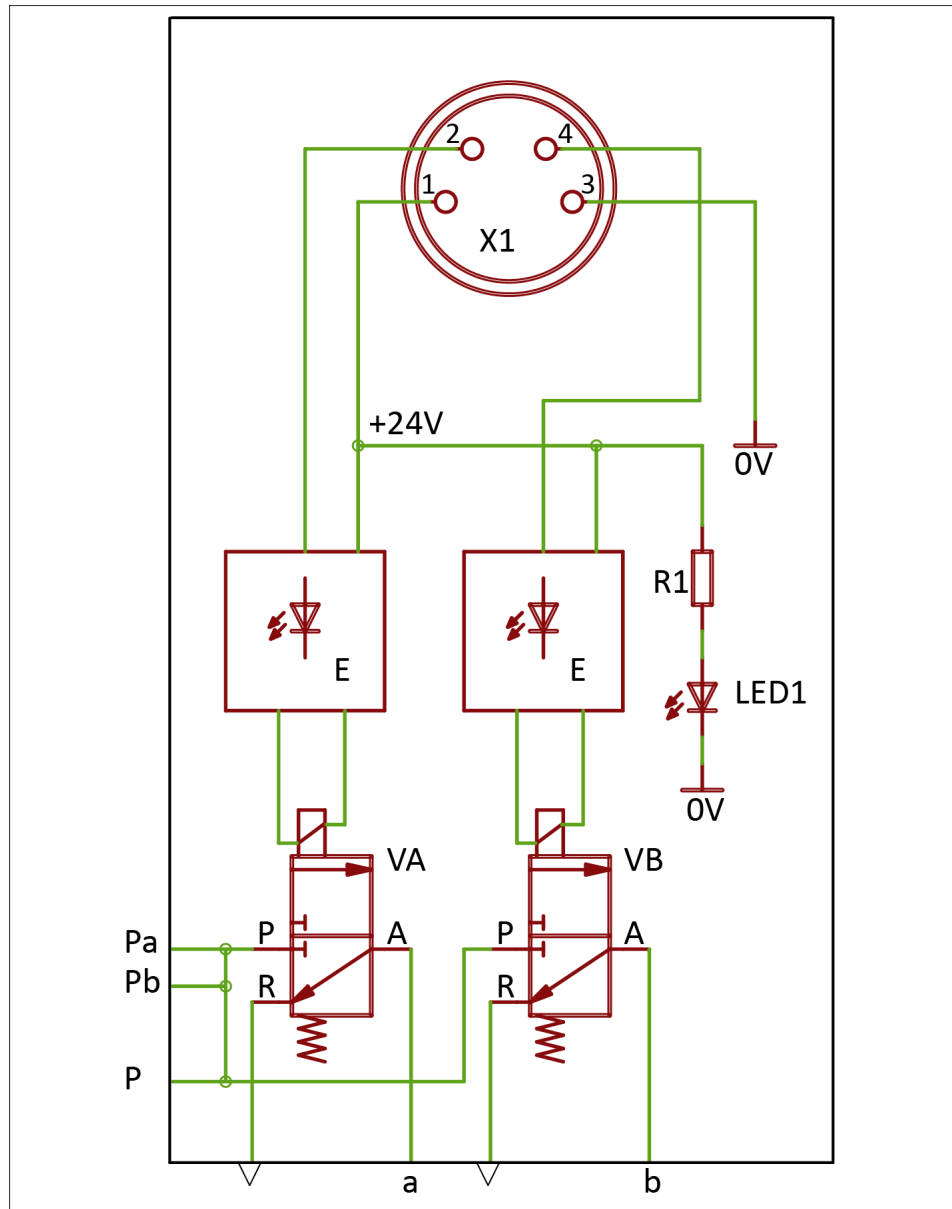



Electrical_pneumatic block diagram

X1	Connection plug for power and actuation signals	P	Supply pressure
E	Control electronics with display	Pa/Pb	Direct air connections
LED1	Operating voltage indicator	a	Outlet for gripper connection A
VA	Valve A	b	Outlet for gripper connection b
VB	Valve B		

8 Assembly

8.1 Mechanical connection

	 WARNING
	<p>Warning: Risk of injury when the machine/system moves unexpectedly! Remove the energy supplies before starting with assembly and adjustments. Make sure that no residual energy remains in the system.</p>

Check the evenness of the bolting surface

The values relate to the entire bolting surface.

Requirements for levelness of the bolting surface (Dimensions in mm)

Diameter	Permissible unevenness
< 100	< 0.02
> 100	< 0.05

- Assembly**
- 1 Unscrew the two studs on the gripper on direct connections a and b.
 - 2 Seal control connections A and B on the gripper with blind plugs.
 - 3 Place the two O-rings provided in the indentations on the valve box.
 - 4 Insert the centering sleeves provided into the allotted stepped bores on the gripper.
 - 5 Screw together the valve box and gripper in one of the ways shown in illustration 3, ([☞ 8.2, Page 17](#)):
 - ⇒ **Assembly a:** With 4 screws through the box into the gripper's thread.
 - ⇒ **Assembly b:** With 4 screws through the gripper and box into an adapter plate for the application.
 - 6 Connect pneumatic supply, ([☞ 8.3, Page 18](#)).
 - 7 Connect electricity supply, ([☞ 8.4, Page 19](#)).
 - 8 Switch on the operating voltage and compressed air supply.
 - 9 Actuate the valves alternately, the gripper should move.

8.2 Assembly options

NOTE

The following illustration is an example, see the enclosed brief introduction (leaflet).

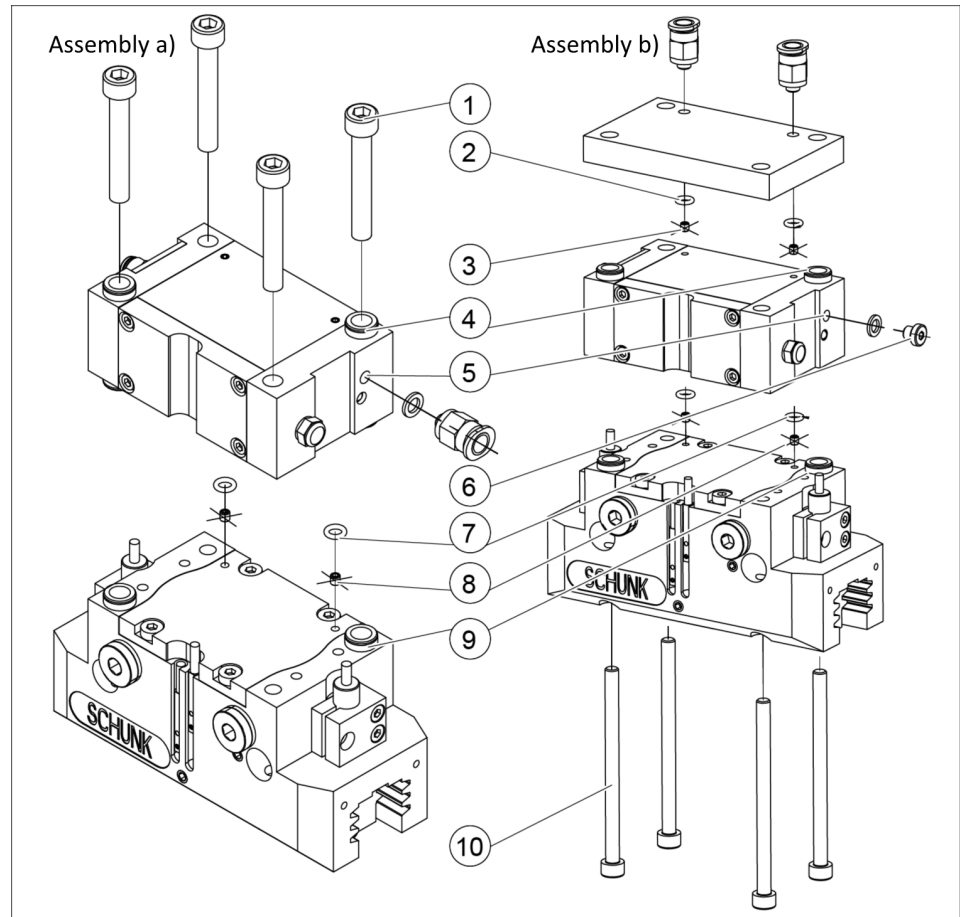

Assembly options, example PNG+ 100

1	DIN EN ISO 4762 screw (provided by customer)	6	Blind plug with sealing ring (accessory pack)
2	O-ring (accessory pack)	7	O-ring (gripper accessory pack)
3	Stud	8	Stud
4	Centering sleeve (accessory pack)	9	Centering sleeve (gripper accessory pack)
5	Air supply	10	DIN EN ISO 4762 screw (provided by customer)

Mounting material (provided by customer)

Mounting screws	64	100
Assembly a)	M5x55 or M5x60	M6x45 or M6x40
Assembly b)	M4x80	M5x75

8.3 Air connections

	! WARNING
	<p>Warning: Risk of injury when the machine/system moves unexpectedly! Remove the energy supplies before starting with assembly and adjustments. Make sure that no residual energy remains in the system.</p>

NOTE

Observe the requirements for the air supply, ([👉 6, Page 11](#)).

Thread diameter of the air connections

Connection	64	100
Hose connection	M5	M5
Direct air connection	M3	M3

The control air outlets on the valve box are located opposite direct connections a and b on the gripper. After the valve box and associated O-rings have been assembled, the gripper is connected to the control air outlets on the valve box.

Using a hose connection

Direct air connections Pa/Pb in the valve box remain sealed.

Using direct air connections Pa/Pb via an adapter plate

The Pa/Pb direct air connections on the valve box are contacted individually or in combination with O-rings on the adapter plate provided by the customer. If this option is used, the two studs on the valve box have to be removed. The positions for the O-ring seat and the centering sleeves in the adapter plate are identical to the positions for the gripper, see catalog data sheet for gripper.

8.4 Electrical connection



WARNING

Warning: Risk of injury when the machine/system moves unexpectedly!

Remove the energy supplies before starting with assembly and adjustments.

Make sure that no residual energy remains in the system.

NOTE

Observe the exact limits of the electrical operating data, ([👉 6, Page 11](#)).

The valve box has a 4-pin M8 plug connector for the power supply. The supply voltage and control signals are fed through this plug connector. The built-in electronic control unit can directly actuate valves with currents of less than 1 mA without a circuit breaker.

NOTE

The +24 V supply line must have a maximum 4 A fuse.

- 1 Insert the M8 connection cable into the valve box connection plug and screw tight.
- 2 Connect control signals and power supply, ([👉 8.5, Page 20](#)).

8.5 Operating display and connector assignment

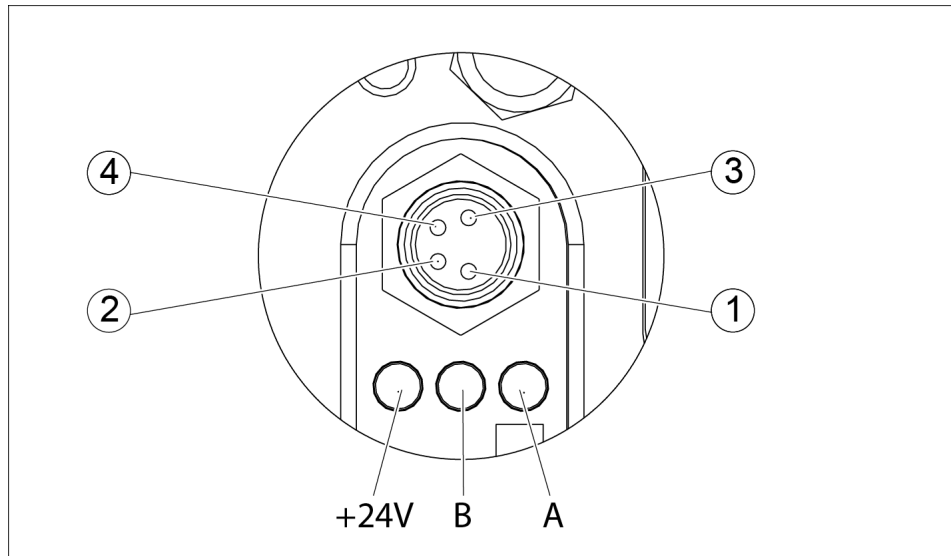

Connector assignment X1

Pos.	Signal	Color	Level
1	+24 V	brown	24 V ± 10 %
2	A	white	Inactive=0 V – 2 V, active=4 V – 26 V
3	GND	blue	0 V
4	B	black	Inactive=0 V – 2 V, active=4 V – 26 V

Pos.	Color	Note
+24 V	green	Operating voltage indicator
B	orange	LED lights up outlet B passing compressed air, gripper closes
A	orange	LED lights up outlet A passing compressed air, gripper opens

If the A and B LEDs are not lit up, connections A and B are vented.

9 Troubleshooting

The troubleshooting chapter only refers to the function and assembly of the valve box.

For help with remedying problems on the gripper, see the operating and assembly instructions for the gripper.

9.1 Operating voltage display or operating displays do not light up

Possible cause	Solution(s)
M8 connection plug not inserted completely.	Check M8 connection plug and secure with knurled nut.
Power supply connected incorrectly or not connected.	Check the connection assignment of the connection cable and correct, if necessary.
Actuation signal outside specification or incorrectly connected.	Check the connection assignment of the connection cable and correct, if necessary. Note level.

9.2 Valves switch but gripper does not move

Possible cause	Solution(s)
Pressure supply missing or below minimum pressure.	Check supply pressure, (↗ 8.3, Page 18).
Studs on direct connections a and b on the gripper were not removed.	Remove studs and install valve box again, (↗ 8.1, Page 16).
Studs on direct connections Pa and Pb on the valve box were not removed.	Remove studs if using direct supply via adapter plate, (↗ 8.1, Page 16).
Valve box is mounted on the gripper at the wrong angle.	Rotate valve box by 180° so that the air connections on the valve box and gripper connect to each other.

9.3 Leakage

Possible cause	Solution(s)
Mounting surface not even enough.	Check that the surface is flat, (👉 8.1, Page 16).
O-rings not mounted.	Check O-rings on air connections Pa, Pb and a, b.
Supply pressure exceeds maximum pressure.	Reduce supply pressure, (👉 6.1, Page 11).

10 Maintenance and care

The valve box is maintenance-free.

11 Declaration of incorporation

in terms of the Directive 2006/42/EG, Annex II, Part 1.B of the European Parliament and of the Council on machinery.

Manufacturer/
Distributor

SCHUNK Electronic Solutions GmbH
Am Tannwald 17
D-78112 St. Georgen

We hereby declare that on the date of the declaration the following incomplete machine complied with all basic safety and health regulations found in the directive 2006/42/EC of the European Parliament and of the Council on machinery. The declaration is rendered invalid if modifications are made to the product.

Product designation Valve box for gripper actuation / PGN+ / electro-pneumatic
ID. No. 0310092, 0310094

The incomplete machine may not be put into operation until conformity of the machine into which the incomplete machine is to be installed with the provisions of the Machinery Directive (2006/42/EC) is confirmed.

Applied harmonized standards, especially:

EN ISO 12100:2010	Safety of machinery – General principles for design – Risk assessment and risk reduction
DIN EN 55016-2-1 2009-12	Conducted interference emissions, industrial sector
DIN EN 61000-4-5 2007-06	Surge immunity test
DIN EN 61000-6-4 2007-09	Emission standard for industrial environments
DIN EN 61000-4-4 2010-11	Electrical fast transient/burst immunity test
DIN EN 61000-4-6 2009-12	Immunity to conducted disturbances, induced by radio-frequency fields

The manufacturer agrees to forward on demand the relevant technical documentation for the partly completed machinery to state offices.

The special technical documents according to Appendix VII, Part B belonging to the incomplete machine have been compiled.

Person authorized to compile the technical documentation:
Markus Ganter, Address: see manufacturer's address



St. Georgen, May 2015

p.p. Matthias Heilmann; Head of Development

12 Appendix on Declaration of Incorporation, as per 2006/42/EC, annex II B

Description of the basic safety and health protection requirements, as per 2006/42/EC, annex I, that apply to and are fulfilled for the scope of the incomplete machine.

Product designation:	Valve box
Type designation:	PGN+
ID number:	0310092, 0310094

To be provided by the system Integrator for the overall machine				
Fulfilled for the scope of the incomplete machine				
Not relevant				
1.1	General information			
1.1.1	Terminology		X	
1.1.2	Basic principles of safety integration			X
1.1.3	Materials and products		X	
1.1.4	Lighting	X		
1.1.5	Engineering design of machine in terms of handling		X	
1.1.6	Ergonomics			X
1.1.7	Operating positions	X		
1.1.8	Seats	X		
1.2	Control units and control devices			
1.2.1	Safety and reliability of control units			X
1.2.2	Controls			X
1.2.3	Starting			X
1.2.4	Stopping			X
1.2.4.1	Normal stopping			X
1.2.4.2	Operational stopping			X
1.2.4.3	Emergency stopping			X
1.2.4.4	All machines			X
1.2.5	Selecting control and operating modes			X
1.2.6	Malfunction of the power supply			X
1.3	Protective measures against mechanical hazards			
1.3.1	Risk of loss of stability			X
1.3.2	Risk of breakage during operation			X
1.3.3	Risk of objects falling or being ejected			X

1.3.4	Risks from surfaces, edges and corners		X	
1.3.5	Risks from combining multiple machines			X
1.3.6	Risks from changes to conditions of use			X
1.3.7	Risks from moving parts			X
1.3.8	Choosing protective equipment against risks from moving parts			X
1.3.8.1	Moving parts for power transmission			X
1.3.8.2	Moving parts involved in the work process			X
1.3.9	Risk of uncontrolled movements			X
1.4	Requirements for protective equipment			
1.4.1	General requirements			X
1.4.2	Special requirements for disconnecting protective equipment			X
1.4.2.1	Fixed disconnecting protective equipment			X
1.4.2.2	Moving disconnecting protective equipment with locking			X
1.4.2.3	Adjustable protective equipment that restrict access			X
1.4.3	Special requirements for non-disconnecting protective equipment			X
1.5	Risks from other hazards			
1.5.1	Electrical power supply			X
1.5.2	Static electricity		X	
1.5.3	Non-electrical power supply		X	
1.5.4	Assembly errors			X
1.5.5	Extreme temperatures			X
1.5.6	Fire			X
1.5.7	Explosion			X
1.5.8	Noise			X
1.5.9	Vibrations			X
1.5.10	Radiation		X	
1.5.11	External radiation		X	
1.5.12	Laser radiation	X		
1.5.13	Emission of hazardous materials and substances	X		
1.5.14	Emission of hazardous materials and substances	X		
1.5.15	Risk of slipping, tripping and falling	X		
1.5.16	Lightning strike			X
1.6	Servicing			
1.6.1	Maintaining the machine			X
1.6.2	Access to operator stands and access points for servicing			X

1.6.3	Disconnecting energy sources			X
1.6.4	Intervention by operating personnel			X
1.6.5	Cleaning internal parts of the machine			X
1.7	Information			
1.7.1	Information and warning signs on the machine			X
1.7.1.1	Information and information facilities			X
1.7.1.2	Warning facilities			X
1.7.2	Warning against residual risks			X
1.7.3	Labeling the machines			X
1.7.4	Operating manual		X	
1.7.4.1	General principles for writing the operating manual		X	
1.7.4.2	Content of the operating manual		X	
1.7.4.3	Sales brochures		X	
	Structure from appendix 1			
2	Additional basic safety and health protection requirements for specific categories of machine			X
2.1	Food machines and machines for cosmetic or pharmaceutical products			X
2.2	Hand-held and/or manually operated portable machines			X
2.2.2	Portable mounting equipment and other impact machinery			X
2.3	Machines for machining wood and materials with similar physical characteristics			X
3	Additional basic safety and health protection requirements for eliminating hazards associated with mobility of machines			X
4	Additional basic safety and health protection requirements for eliminating hazards caused by lifting operations			X
5	Additional basic safety and health protection requirements for machines intended for use underground			X
6	Additional basic safety and health protection requirements for machines that cause hazards due to lifting of persons			X

