



Assembly and Operating Manual

ERM

Electric Rotary Module with Servo Motor

Translation of Original Operating
Manual

Hand in hand for tomorrow

Imprint

Copyright:

This manual is protected by copyright. The author is SCHUNK SE & Co. KG.
All rights reserved.

Technical changes:

We reserve the right to make alterations for the purpose of technical improvement.

Document number: 0389540

Version: 06.00 | 08/10/2025 | en

Dear Customer,

Thank you for trusting our products and our family-owned company, the leading technology supplier of robots and production machines.

Our team is always available to answer any questions on this product and other solutions. Ask us questions and challenge us. We will find a solution!

Best regards,

Your SCHUNK team

Customer Management

Tel. +49-7133-103-2503

Fax +49-7133-103-2189

cmg@de.schunk.com



Please read the operating manual in full and keep it close to the product.

Table of Contents

| | |
|------------------------------------------------------------|-----------|
| 1 General | 5 |
| 1.1 About this manual..... | 5 |
| 1.1.1 Presentation of Warning Labels | 5 |
| 1.1.2 Applicable documents | 6 |
| 1.1.3 Variants | 6 |
| 1.2 Warranty | 6 |
| 1.3 Scope of delivery..... | 6 |
| 1.4 Accessories | 6 |
| 2 Basic safety notes | 8 |
| 2.1 Intended use..... | 8 |
| 2.2 Not intended use | 8 |
| 2.3 Constructional changes..... | 8 |
| 2.4 Environmental and operating conditions..... | 8 |
| 2.5 Personnel qualification | 9 |
| 2.6 Personal protective equipment | 10 |
| 2.7 Notes on safe operation..... | 10 |
| 2.8 Transport..... | 11 |
| 2.9 Malfunctions | 11 |
| 2.10 Disposal | 11 |
| 2.11 Fundamental dangers | 11 |
| 2.11.1 Protection during handling and assembly | 12 |
| 2.11.2 Protection during commissioning and operation | 12 |
| 2.11.3 Protection against dangerous movements | 12 |
| 2.11.4 Protection against electric shock..... | 13 |
| 2.12 Notes on particular risks | 15 |
| 3 Technical Data | 19 |
| 3.1 Type Key and Name Plate | 19 |
| 3.2 Basic data | 19 |
| 4 Design and Description | 21 |
| 5 Transport and storage | 22 |
| 5.1 Transport..... | 22 |
| 5.2 Storage | 22 |
| 6 Assembly | 23 |
| 6.1 Twist transmission housing | 23 |
| 6.2 Mount servo motors..... | 25 |
| 6.3 Mount rotary module onto a machine/system..... | 27 |
| 6.4 Electrical connection..... | 31 |

| | |
|----------------------------------------------------------------------------------------------------------------|-----------|
| 7 Start-up | 32 |
| 7.1 Adjusting the movement and control parameters, and the exact limits in the controller | 33 |
| 8 Troubleshooting..... | 37 |
| 8.1 Module does not move?..... | 37 |
| 8.2 Does the module not provide the correct rotating angle? | 37 |
| 8.3 Torque drops..... | 37 |
| 8.4 Does module rotate jerkily or overshoot end position? | 38 |
| 8.5 Does module overshoot significantly at end positions? | 38 |
| 8.6 Is module turning too quickly / too slowly? | 38 |
| 9 Maintenance | 39 |
| 9.1 Disassemble servo motor and motor adapter..... | 42 |
| 9.2 Replacing the media feed-through seals | 43 |
| 9.3 Mount seals of the media feed-through with the assembly device ERM 160-MDF | 45 |
| 9.4 Oil Change | 49 |
| 9.5 Replace radial shaft sealing rings | 51 |
| 10 Disposal | 52 |
| 11 Translation of the original declaration of incorporation | 54 |
| 12 UKCA declaration of incorporation | 55 |
| 13 Information on the RoHS Directive, REACH Regulation and Substances of Very High Concern (SVHC) | 56 |

1 General

1.1 About this manual

This manual contains important information for a safe and appropriate use of the product.

This manual is an integral part of the product and must be kept accessible for the personnel at all times.

Before starting work, the personnel must have read and understood this operating manual. Prerequisite for safe working is the observance of all safety instructions in this manual.

In addition to these instructions, the documents listed under ► 1.1.2 [6] are applicable.

NOTE: The illustrations in this manual are intended to provide a basic understanding and may deviate from the actual version.

1.1.1 Presentation of Warning Labels

To make risks clear, the following signal words and symbols are used for safety notes.



⚠ DANGER

Dangers for persons!

Non-observance will inevitably cause irreversible injury or death.



⚠ WARNING

Dangers for persons!

Non-observance can lead to irreversible injury and even death.



⚠ CAUTION

Dangers for persons!

Non-observance can cause minor injuries.

NOTICE

Material damage!

Information about avoiding material damage.

1.1.2 Applicable documents

- General terms of business *
- Catalog data sheet of the purchased product *
- Assembly and operating manuals of the accessories *

The documents labeled with an asterisk (*) can be downloaded from [schunk.com/downloads](https://www.schunk.com/downloads).

1.1.3 Variants

This operating manual applies to the following variations:

- ERM 160-8-CB-B
- ERM 160-8-CB-B with motor add-on kit supplied separately
- ERM160-8-CB-MSK050B

1.2 Warranty

If the product is used as intended, the warranty is valid for 24 months from the ex-works delivery date under the following conditions:

- Observe the maximum service life. ▶ 3 [📄 19]
- Observe the ambient conditions and operating conditions, ▶ 2.4 [📄 8]
- Observe the specified maintenance and lubrication intervals, ▶ 9 [📄 39]

Parts touching the workpiece and wear parts are not included in the warranty.

1.3 Scope of delivery

The scope of delivery includes

- Electric rotary module in the version ordered.
- Assembly and Operating Manual
- Assembly and operating manual for motor used
- Accessory pack

1.4 Accessories

The following accessories, which must be ordered separately, are required for the product:

- Motor add-on kit (included in scope of delivery for the version with a standard motor)
- Servomotor (included in scope of delivery for the version with a standard motor)
- Drive controller
- Cable set

Drive controller

SCHUNK can offer advice on drive parameter settings for the following drive controllers: BOSCH (EcoDrive CS, IndraDrive and IndraDrive CS) and Siemens (Sinamics S120).

SCHUNK provides motor data sheets for operating the product on other drive controllers and can provide support with commissioning on request. Comprehensive support cannot be guaranteed.

Optional accessories

- Sealing kit for rotary feed-through
- Maintenance kit for rotary feed-through
- Sealing kit with radial shaft sealing rings
- Maintenance kit for radial shaft sealing rings

I.D. numbers of the sealing and maintenance kits, ► 9 [📄 40]

2 Basic safety notes

2.1 Intended use

The product may only be used for turning, swivelling and positioning workpieces or other automation components.

The product is exclusively designed for linear movement of useful loads into any position where the load does not react in a manner endangering persons, property or the environment as a result of this manipulation.

- The product may only be used within the scope of its technical data, ▶ 3 [19].
- The product is intended for installation in a machine/ automated system. The applicable guidelines for the machine/ automated system must be observed and complied with.
- The product is intended for industrial and industry-oriented use.
- Appropriate use of the product includes compliance with all instructions in this manual.

2.2 Not intended use

It is not intended use if the product is used, for example, as a pressing tool, stamping tool, lifting gear, guide for tools, cutting tool, clamping device or a drilling tool.

- Any utilization that exceeds or differs from the appropriate use is regarded as misuse.

2.3 Constructional changes

Implementation of structural changes

Modifications, changes or reworking, e.g. additional threads, holes, or safety devices, can damage the product or impair its functionality or safety.

- Structural changes should only be made with the written approval of SCHUNK.

2.4 Environmental and operating conditions

- Make sure that the product is a sufficient size for the application.
- Ensure that maintenance and lubrication intervals are observed, ▶ 9 [39].
- Ensure the environmental conditions are suitable for products with the indicated protection types, ▶ 3 [19].

- Make sure that the product's range of application is outside the explosive area. Excepted are products which were designed for explosive areas.

2.5 Personnel qualification

Inadequate qualifications of the personnel

If the personnel working with the product is not sufficiently qualified, the result may be serious injuries and significant property damage.

- All work may only be performed by qualified personnel.
- Before working with the product, the personnel must have read and understood the complete assembly and operating manual.
- Observe the national safety regulations and rules and general safety instructions.

The following personal qualifications are necessary for the various activities related to the product:

Trained electrician

Due to their technical training, knowledge and experience, trained electricians are able to work on electrical systems, recognize and avoid possible dangers and know the relevant standards and regulations.

Qualified personnel

Due to its technical training, knowledge and experience, qualified personnel is able to perform the delegated tasks, recognize and avoid possible dangers and knows the relevant standards and regulations.

Instructed person

Instructed persons were instructed by the operator about the delegated tasks and possible dangers due to improper behaviour.

Service personnel of the manufacturer

Due to its technical training, knowledge and experience, service personnel of the manufacturer is able to perform the delegated tasks and to recognize and avoid possible dangers.

2.6 Personal protective equipment

Use of personal protective equipment

Personal protective equipment serves to protect staff against danger which may interfere with their health or safety at work.

- When working on and with the product, observe the occupational health and safety regulations and wear the required personal protective equipment.
- Observe the valid safety and accident prevention regulations.
- Wear protective gloves to guard against sharp edges and corners or rough surfaces.
- Wear heat-resistant protective gloves when handling hot surfaces.
- Wear protective gloves and safety goggles when handling hazardous substances.
- Wear close-fitting protective clothing and also wear long hair in a hairnet when dealing with moving components.

2.7 Notes on safe operation

Incorrect handling of the personnel

Incorrect handling and assembly may impair the product's safety and cause serious injuries and considerable material damage.

- Avoid any manner of working that may interfere with the function and operational safety of the product.
- Use the product as intended.
- Observe the safety notes and assembly instructions.
- Do not expose the product to any corrosive media. This does not apply to products that are designed for special environments.
- Eliminate any malfunction immediately.
- Observe the care and maintenance instructions.
- Observe the current safety, accident prevention and environmental protection regulations regarding the product's application field.

2.8 Transport

Handling during transport

Incorrect handling during transport may impair the product's safety and cause serious injuries and considerable material damage.

- When handling heavy weights, use lifting equipment to lift the product and transport it by appropriate means.
- Secure the product against falling during transportation and handling.
- Stand clear of suspended loads.

2.9 Malfunctions

Behavior in case of malfunctions

- Immediately remove the product from operation and report the malfunction to the responsible departments/persons.
- Order appropriately trained personnel to rectify the malfunction.
- Do not recommission the product until the malfunction has been rectified.
- Test the product after a malfunction to establish whether it still functions properly and no increased risks have arisen.

2.10 Disposal

Handling of disposal

The incorrect handling of disposal may impair the product's safety and cause serious injuries as well as considerable material and environmental harm.

- Follow local regulations on dispatching product components for recycling or proper disposal.

2.11 Fundamental dangers

General

- Observe safety distances.
- Never deactivate safety devices.
- Before commissioning the product, take appropriate protective measures to secure the danger zone.
- Disconnect power sources before installation, modification, maintenance, or calibration. Ensure that no residual energy remains in the system.
- If the energy supply is connected, do not move any parts by hand.

- Do not reach into the open mechanism or movement area of the product during operation.

2.11.1 Protection during handling and assembly

Incorrect handling and assembly

Incorrect handling and assembly may impair the product's safety and cause serious injuries and considerable material damage.

- Have all work carried out by appropriately qualified personnel.
- For all work, secure the product against accidental operation.
- Observe the relevant accident prevention rules.
- Use suitable assembly and transport equipment and take precautions to prevent jamming and crushing.

Incorrect lifting of loads

Falling loads may cause serious injuries and even death.

- Stand clear of suspended loads and do not step into their swiveling range.
- Never move loads without supervision.
- Do not leave suspended loads unattended.

2.11.2 Protection during commissioning and operation

Falling or violently ejected components

Falling and violently ejected components can cause serious injuries and even death.

- Take appropriate protective measures to secure the danger zone.
- Never step into the danger zone during operation.

2.11.3 Protection against dangerous movements

Unexpected movements

Residual energy in the system may cause serious injuries while working with the product.

- Switch off the energy supply, ensure that no residual energy remains and secure against inadvertent reactivation.
- The faulty actuation of connected drives may cause dangerous movements.
- Operating mistakes, faulty parameterization during commissioning or software errors may trigger dangerous movements.
- Never rely solely on the response of the monitoring function to avert danger. Until the installed monitors become effective, it must be assumed that the drive movement is faulty, with its

action being dependent on the control unit and the current operating condition of the drive. Perform maintenance work, modifications, and attachments outside the danger zone defined by the movement range.

- To avoid accidents and/or material damage, human access to the movement range of the machine must be restricted. Limit/prevent accidental access for people in this area due through technical safety measures. The protective cover and protective fence must be rigid enough to withstand the maximum possible movement energy. EMERGENCY STOP switches must be easily and quickly accessible. Before starting up the machine or automated system, check that the EMERGENCY STOP system is working. Prevent operation of the machine if this protective equipment does not function correctly.

2.11.4 Protection against electric shock

Working on electrical equipment

Touching live parts can lead to death.

- Work on electrical equipment may only be carried out by qualified electricians in accordance with electrotechnical regulations.
- Lay electrical cables properly, e.g. in a cable duct or cable bridge. Observe standards.
- Before connecting or disconnecting electrical cables: Switch off the power supply and secure it against being switched on again, check that the cables are de-energized.
- Before switching on / commissioning the product, check that the protective earth conductor is correctly attached to all electrical components in accordance with the wiring diagram.
- Check whether covers and protective devices have been fitted to prevent contact with live components.
- Do not touch the connection points of the product when the power supply is switched on.

Possible electrostatic energy

Components or assembly groups may become electrostatically charged. When the electrostatic charge is touched, the discharge may trigger a shock reaction leading to injuries.

- The operator must ensure that all components and assembly groups are included in the local potential equalisation in accordance with the applicable regulations.

- While paying attention to the actual conditions of the working environment, the potential equalisation must be implemented by a specialist electrician according to the applicable regulations.
- The effectiveness of the potential equalisation must be verified by executing regular safety measurements.

2.12 Notes on particular risks



⚠ WARNING

Risk of injury from objects falling and being ejected!

Falling objects and objects being ejected can cause severe injuries.

- Ensure that the danger zone is enclosed by protective fencing during operation.
- Mount the product onto the machine and the motor and the attachments onto the product with extra care.
- Adjust the operating conditions, e.g. reduce speed and acceleration, comply with exact limits.
- Take particular care when laying out the components.
- Make sure the correct screws and tightening torques are used.
- Wear protective clothing during assembly.



⚠ WARNING

Risk of injury due to moving parts coming into proximity with stationary parts!

Moving components may cause severe injuries. Body parts may get crushed and bruised.

- Ensure that the danger zone is enclosed by protective fencing during operation.
- Exercise particular caution during start-up.



⚠ WARNING

Risk of injury due to sudden and unexpected movement of the machine/system!

When the energy supply fails or the components malfunction, parts may move unexpectedly and cause severe injuries.

- Only expert personnel may operate.
- Ensure that the danger zone (rotation of the add-on parts by a full 360°) is enclosed by protective fencing during operation.
- Exercise particular caution during start-up (selection of movement and control parameters, setting of drive limits, caution during cabling and wiring).
- Take any additional movements and forces acting on the rotary module from outside into account.
- Exercise particular caution when restarting after motor/ controller reference loss or after disassembly of the attachments/module from the machine. Provide acknowledgment of the error message after a reference loss.
- Disassembly of the attachments/the module from the machine is only to be carried out in a defined position. Ensure re-assembly of attachments with correct alignment after maintenance / disassembly.
- Fit a holding brake on the motor. The motor holding brake is not suitable for personnel protection.
- Avoid an uncontrolled emergency stop (application of the holding brake during movement). The motor holding brake is not suitable for an emergency stop.
- Fit external holding devices if disassembly of the motor is necessary while the attachments are in a position with potential residual energy.
- Operation in EMC-safe environment and in a suitable environment in accordance with specified protection class, ▶ 3 [19].
- Avoiding jamming (for example, due to presence of large interfering particles between the attachments and the rotary module housing) or impacts on interfering contours.
- Avoid thermal overload in the motor.
- Only transfer suitable media through the media feed-through.



⚠ WARNING

Risk of injury due to endless movement!

- Ensure that the danger zone is enclosed by protective fencing during operation.
- Prevent destruction of attachments and their energy supply (cables/hoses) using suitable guides/feed-throughs and movement limits.
- Check the position status (reference) of the motor sensor before starting.



⚠ WARNING

Risk of injury from electric shock due to contact with live parts!

- Observe the motor operating manual.
- Before conducting any work on the machine and peripheral equipment, disconnect them from the power supply (load and logic voltage) and secure them against re-activation.
- Wait until the frequency converter/controller is discharged.



⚠ WARNING

Risk of burns due to contact with hot surfaces!

During operation, the surface temperatures of components (for example, engine and housing) may reach over 100°C.

- Observe the motor operating manual.
- Prior to starting work on the module, allow it to cool down to no more than 40°C. If the cooling down time cannot be maintained, wear protective gloves.



⚠ WARNING

Risk of injury due to rotating components!

- Ensure that the danger zone (rotation of the add-on parts by 360°) is enclosed by protective fencing during operation.
- Exercise particular caution during start-up.



⚠ WARNING

Risk of injury from inhaling harmful vapors!

- Leave the danger zone in the event of fire or smoldering in the electronic system immediately.
- Ensure sufficient ventilation.



⚠ WARNING

Risk of injury due to escaping hydraulic oil!

- Carry out a regular visual inspection for leaks.
- Replace defective seals immediately.
- Never remove the loss prevention device on the transmission housing.
- Do not open the locking screws.
- Place a collecting trough underneath when changing the oil.
- Observe the speed and temperature limits.



⚠ WARNING

Risk of injury due to escaping media!

- Only transfer suitable media through the media infeed.
- Regularly monitor seal.
- Replace defective seals immediately.
- Observe the speed and temperature limits.

3 Technical Data

3.1 Type Key and Name Plate

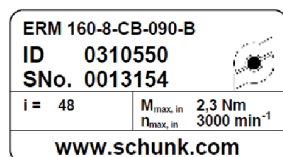
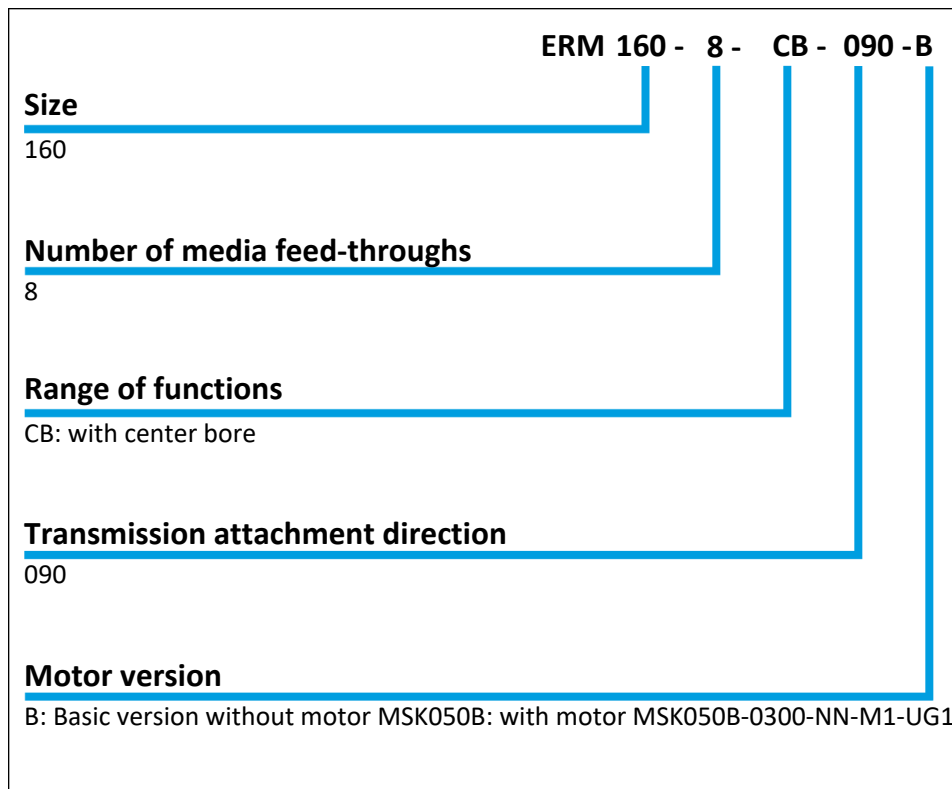

| | |
|-----------|----------------------|
| i | Gear ratio |
| M max, in | Maximum input torque |
| n max, in | Maximum drive speed |

3.2 Basic data

| Variant | ERM160-MDF-090-B | ERM160-MDF-090-MSK050B |
|----------------------------------------------------------------------------|-----------------------------------------------------------------------------|------------------------|
| Weight [kg] | 15.5 | 21.5 |
| Maximum permissible output side load moment of inertia [kgm ²] | 20 | 20 |
| Max. permissible input torque [Nm] | 2.3* | 2.3 * |
| Max. permissible drive speed [rpm] | 3000 * | 3000 * |
| Max. permissible input torque for emergency stop [Nm] | 5 */** | 5 */** |
| Transmission ratio | 48 | 48 |
| Pressure medium | Compressed air, compressed air quality according to ISO 8573-1:2010 [7:4:4] | |
| Max. media feed-through pressure [bar] | 8 | 8 |

| Variant | ERM160-MDF-090-B | ERM160-MDF-090-MSK050B |
|---------------------------------------------------------------------|-------------------------|-------------------------------|
| Gear mass moment of inertia (relative to drive) [kgm ²] | 0.000063 | 0.000063 |
| Max. permissible axial force Fz [N] | 3000 | 3000 |
| Max. permissible radial force Fx [N] | 1500 | 1500 |
| Max. permissible moment load capacity My [Nm] | 450 | 450 |
| Ambient temperature [°C] | | |
| Min. | +5 | +5 |
| Max. | +55 | +55 |
| IP rating | 65 | 65 |

* Values relate to the rotary module input shaft

**Can occur a maximum of 100 times

| Designation | ERM |
|----------------------------|------------|
| Warranty duration [months] | 24 |
| or maximum cycles [mil.]* | 10 |

Tab.: Warranty

*) A cycle consists of two swivel processes: 0° to 180° and 180° to 0°

4 Design and Description

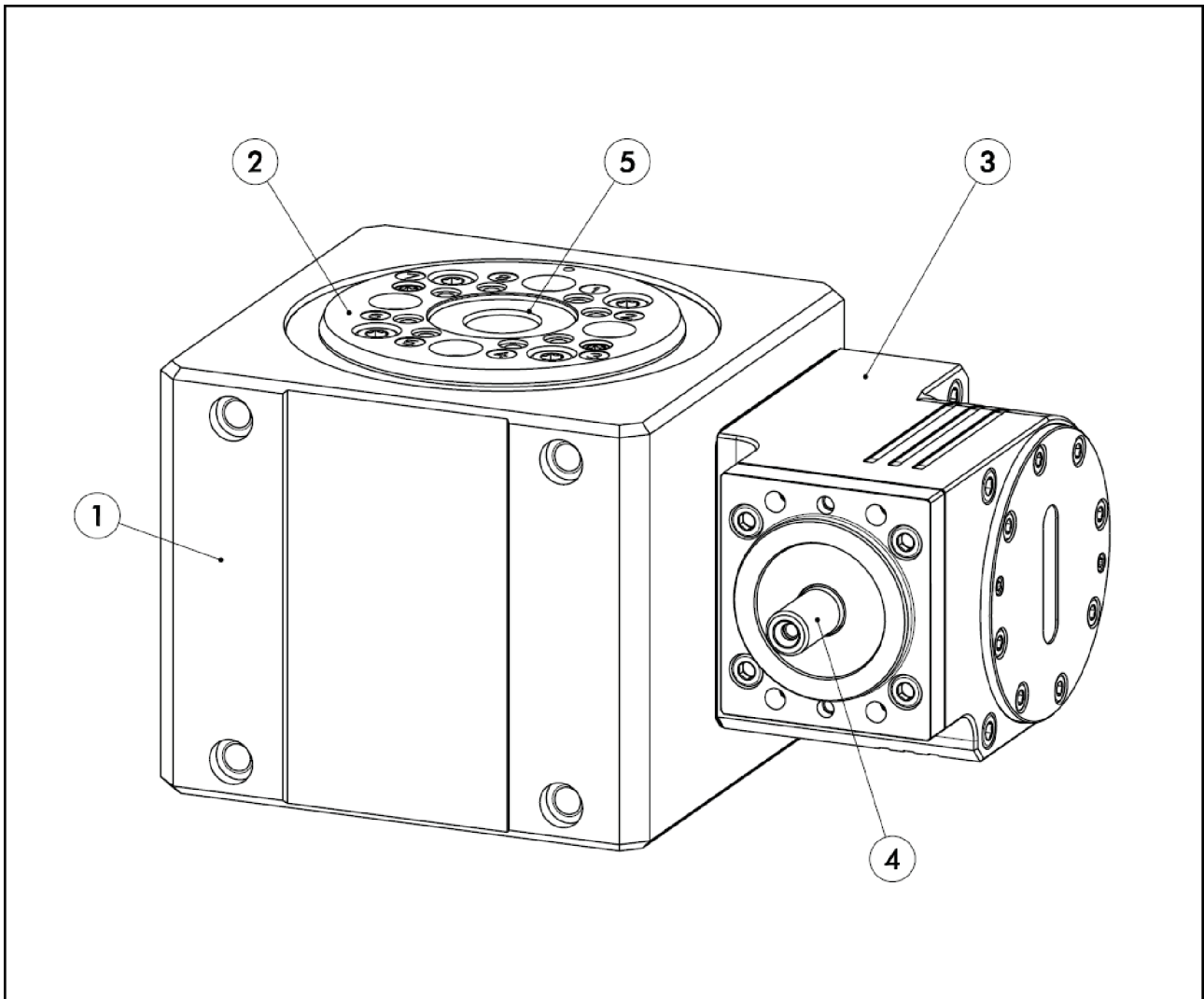

| | |
|---|----------------------------------------------------------------------------------------------------|
| 1 | Main module |
| 2 | Output flange (flange shaft) with compressed air connections for rotary feed-through |
| 3 | Transmission housing (twistable) |
| 4 | Drive shaft |
| 5 | Distributor flange for rotary feed-through with center bore (compressed air connections on bottom) |

The torque of the motor is transferred from the driving shaft via the two-stage hypoid gearing to the output flange.

The media feed-through enables compressed air to be fed from the connection on the distributor flange to the connection on the output flange.

The alignment of the transmission housing is adjustable in $4 \times 90^\circ$ increments (before mounting of the module or attachments).

5 Transport and storage

5.1 Transport

1. The packaging must protect the drive from all external effects (such as mechanical shocks and humidity).
2. Protect the module from shocks!
3. Remove the electrical feed lines before transportation.
4. Comply with climatic category 2K3 in accordance with EN50178.
5. Transport temperature -5 to $+60^{\circ}\text{C}$, with maximum fluctuations of 20 K/hour.
6. Transport humidity: Relative humidity 5%–95%, non-condensing.
7. The adapted ERM motor contains components that are sensitive to electrostatic charge. Avoid electrostatic charge.

5.2 Storage

1. Protect the motor from the effects of moisture.
2. The storage temperature must be between $+5^{\circ}\text{C}$ and $+20^{\circ}\text{C}$.
3. The storage location must be clean, dry, and moderately ventilated. Provide protection against the effects of light, oxygen, and ozone. Observe DIN 7716 for rubber products.
4. No outdoor storage permitted.
5. Condensation is not permitted.
6. Comply with climatic category 1K4 in accordance with EN50178.
7. The maximum storage time is four years due to the inclusion of NBR seals.
8. Observe the maximum stacking height of three packaged modules.
9. Secure the storage location against escape of leaked oil.
10. Move the gear every six months by turning the drive shaft.

6 Assembly

6.1 Twist transmission housing



⚠ WARNING

Risk of injury due to escaping hydraulic oil!

- Never remove the loss prevention device (6) on the transmission housing.
- Do not open the locking screws.



⚠ WARNING

Risk of injury due to sudden and unexpected movement of the machine/system!

- Twisting of the transmission must be carried out before assembly of the rotary module on the machine and before assembly of the attachments on the rotary module.

NOTICE

Change to backlash due to damage to fitting disks!

- Only to be assembled by expert personnel.

NOTICE

The transmission (2) is secured against falling out by a loss prevention device (6). If the loss prevention device is deliberately unscrewed, hydraulic oil escapes.

- Do not remove the loss prevention device.

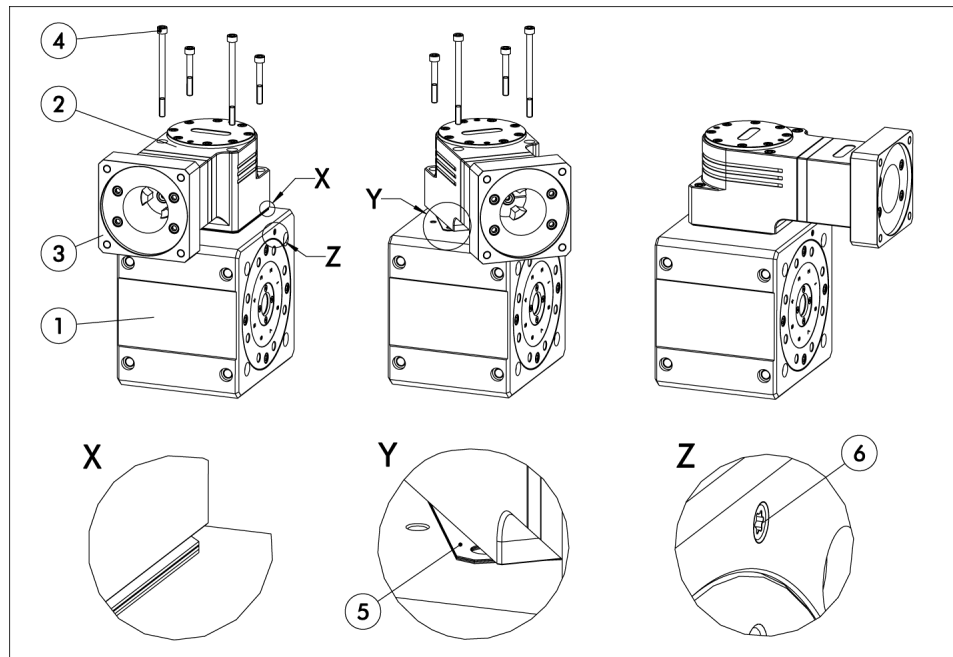

- 1.** Secure the rotary module on the base in such a way that the transmission (2) is on top.
 - ⇒ The mounting may only engage on the housing (1), but the drive shaft and output flange must move freely.
- 2.** Recommendation: Before twisting, fastening the motor adapter (3) on the transmission (2).
 - ⇒ Twisting is relatively stiff. The large lever arm makes twisting easier.
- 3.** Unscrew the four screws (4) and completely remove all screws from the transmission.
- 4.** Turn the transmission (2) by 90°, 180°, or 270° to the required direction by hand.
 - ⇒ Because of the serration, the transmission may lift around 1 mm from the main module (see detail X) until it is in contact with the loss prevention device (6). If necessary, the process can be supported by simultaneously turning the drive shaft (7).
 - ⇒ If the transmission cannot be turned easily, check whether it can be twisted more easily in the other direction.
 - ⇒ When twisting, make sure that any fitting disks located between the housings (5) are twisted as well. The bore holes of the fitting disks must all lie precisely above the bore holes of the transmission and the main module.
- 5.** Carefully fit the four screws (4) through the transmission. The fitting disks may not be damaged when doing this.

6. Tighten the screws to a **tightening torque of 14.9 Nm**.
7. Check the movement of the rotary module by turning the drive shaft (7).

6.2 Mount servo motors



⚠ WARNING

Risk of injury due to unexpected movements of the machine/ automated system!

- Before beginning any work on the machine and peripheral equipment, disconnect them from the power supply (load and logic voltage) and secure against re-activation.
- Wait until the frequency converter/controller is discharged.



⚠ WARNING

Risk of injury from falling objects!

- Ensure careful attachment of the module to the machine.
- Ensure careful attachment of the motor to the module.
- Ensure careful attachment of the attachments to the rotary module.
- Make sure the correct screws and tightening torques are used.
- Wear protective clothing during assembly.

Attachment of coupling to gear and motor

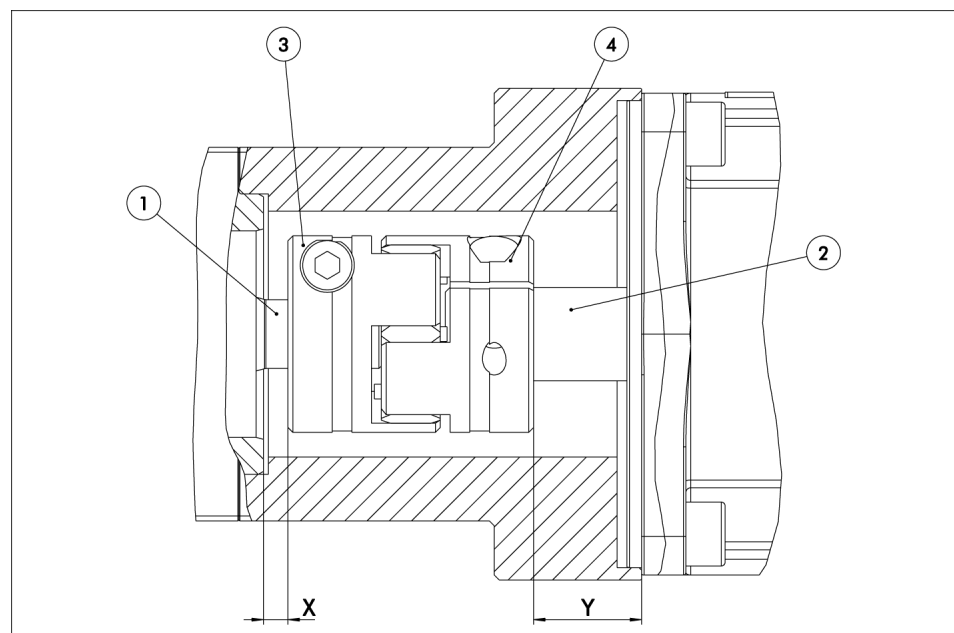

Attachment of standard coupling to motor

| ID number MAS | Designation | Dimension X | Dimension Y |
|---------------|-----------------------------------|-------------|-------------|
| 0310567 | MAS-ERM 160-14-050-09 5-M06 | 8.0 -0.3 | 13.0 -0.3 |
| 0310568 | MAS-ERM 160-14-060-07 5-M06 | 5.5 -0.3 | 10.0 -0.3 |
| 0310572 | MAS-ERM 160-19-080-10 0-M06 | 8.0 -0.3 | 23.0 -0.3 |
| 0310573 | MAS-ERM 160-19-095-115 -M08 | 5.5 -0.3 | 22.0 -0.3 |

1. Fit the coupling half (3) on the rotary module shaft (1) and adjust the dimension "X" in line with the table.
2. Tighten the coupling half (3) screw to a **tightening torque of 10 Nm**.
3. Fit the coupling half (4) on the motor shaft (2) and adjust the dimension "Y" in line with the table.
4. Tighten the screw to a **tightening torque of 10 Nm**.

Attachment of motor adapter and servo motor to rotary module

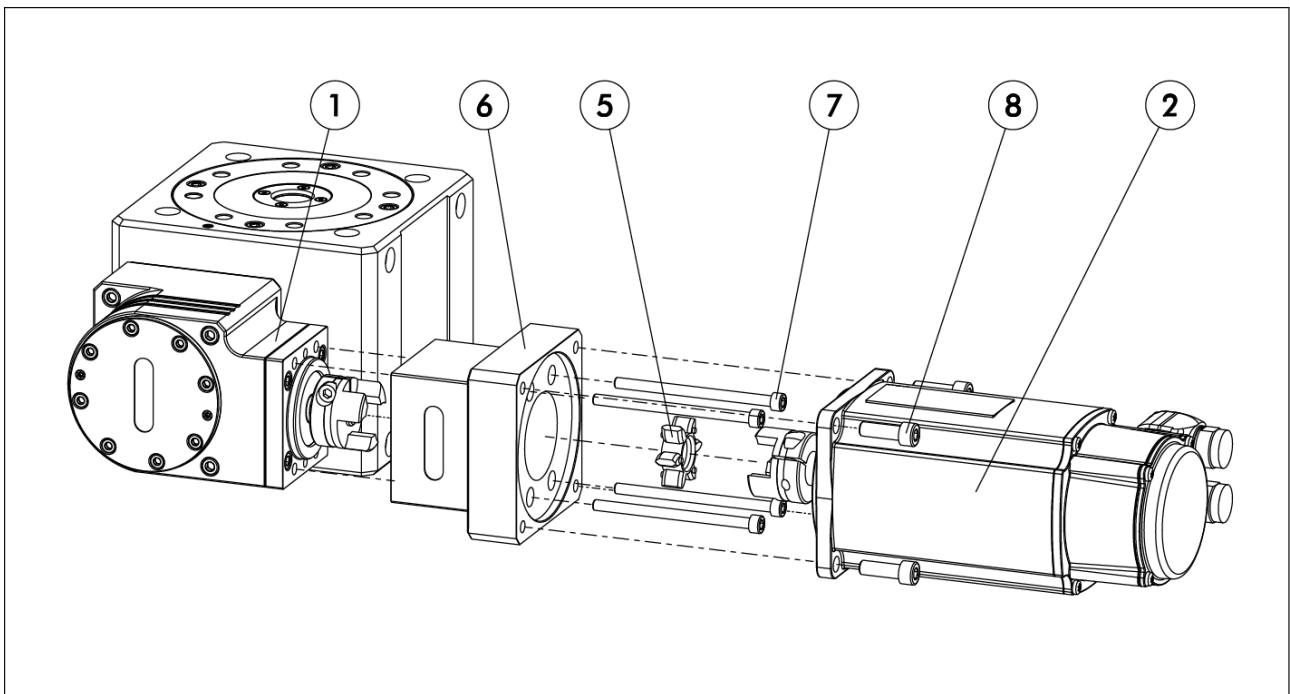

Attachment of motor adapter and servo motor to rotary module

1. Fasten motor adapter (6) to the transmission housing (1) using screws (7). **Observe tightening torque of 10.1 Nm.** Observe alignment of the motor adapter.
2. Fit the crown gear on the coupling (5).

3. Fit the motor (2) on the motor adapter (6). Observe the alignment of the coupling.
4. Attach motor to the motor adapter using the mounting screws (8). Observe tightening torques in accordance with the following table.

| Thread | Tightening torque [Nm] |
|--------|------------------------|
| M5 | 5.9 |
| M6 | 10.1 |
| M8 | 24.6 |

Tab.: Tightening torque depending on thread diameter

6.3 Mount rotary module onto a machine/system



⚠ WARNING

Risk of injury due to unexpected movements of the machine/automated system!

- Before conducting any work on the machine and peripheral equipment, disconnect them from the power supply (load and logic voltage) and secure against re-activation.
- Wait until the frequency converter/controller is discharged.
- Use an index bore hole to ensure re-assembly of attachments in the correct alignment after subsequent maintenance work.



⚠ WARNING

Risk of injury from falling objects!

- Ensure careful attachment of the module to the machine.
- Ensure careful attachment of the motor to the module.
- Ensure careful attachment of the attachments to the rotary module.
- Make sure the correct screws and tightening torques are used.
- Wear protective clothing during assembly.

Evenness of the mounting surface

The values apply to the whole mounting surface to which the product is mounted.

| Edge length | Permissible unevenness |
|-------------|------------------------|
| < 100 | < 0.02 |
| > 100 | < 0.05 |

Tab.: Requirements for evenness of the mounting surface (Dimensions in mm)

ERM assembly on a machine/automated system

NOTE

- Screws up to strength class 12.9 can be used.
- The depth of engagement for the screws in the ERM depends on which side they are screwed in.
- The supporting thread length may not be less than 15 mm.
- Connection dimensions can be found in the catalog.
- Two centering sleeves are necessary for positioning.

The module can be attached to a machine/automated system at one of 4 sides. The three other sides may then have a limited depth of engagement.

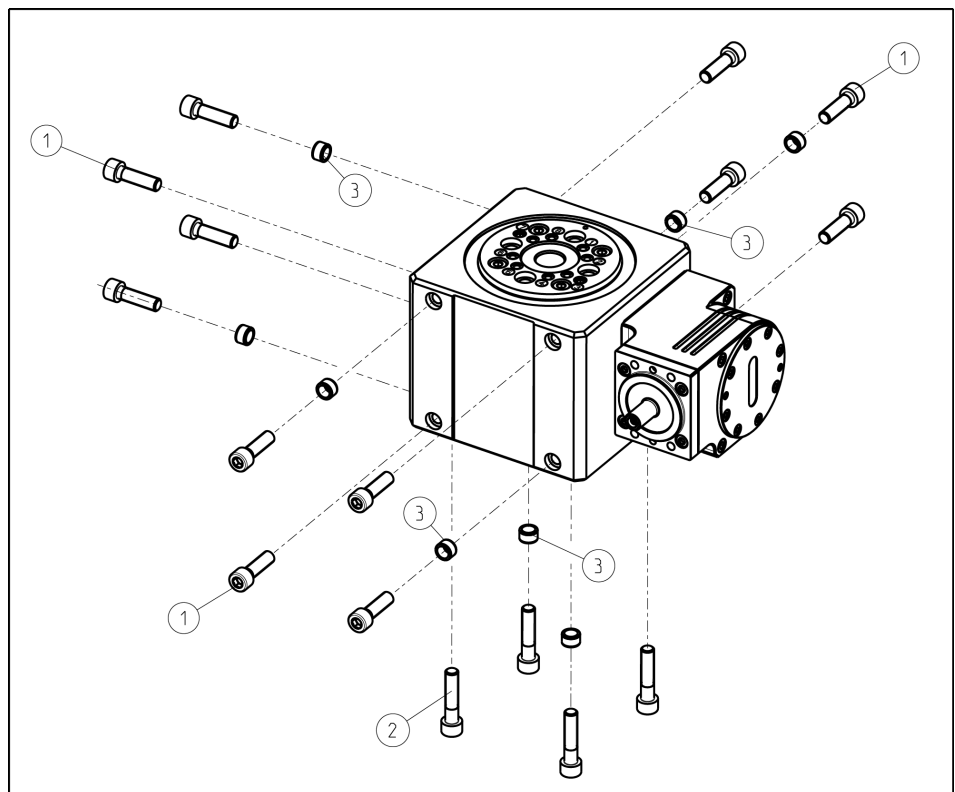

- The screws (1) and (2) are not included in the scope of delivery.
 - The centering sleeves $\varnothing 14$ (3) are included in the accessory pack.
1. Make sure that the flatness of the screw surface on the gantry complies with the requirements, see previous table.
 2. Attach rotary module to the portal with four screws M10 (1) or (2) and two centering sleeves (3).

Assembly of attachments on the ERM

NOTE

- Screws up to strength class 12.9 can be used.
- The supporting thread length may not be less than 15 mm.
- Connection dimensions can be found in the catalog.
- The output flange has an index bore hole, which can be used to ensure that the attachments are assembled with the correct alignment (for example, important for subsequent maintenance work).
- Fit O-rings in the connections that are not used to prevent liquid from getting into the bore holes.
- Two centering sleeves are necessary for positioning.

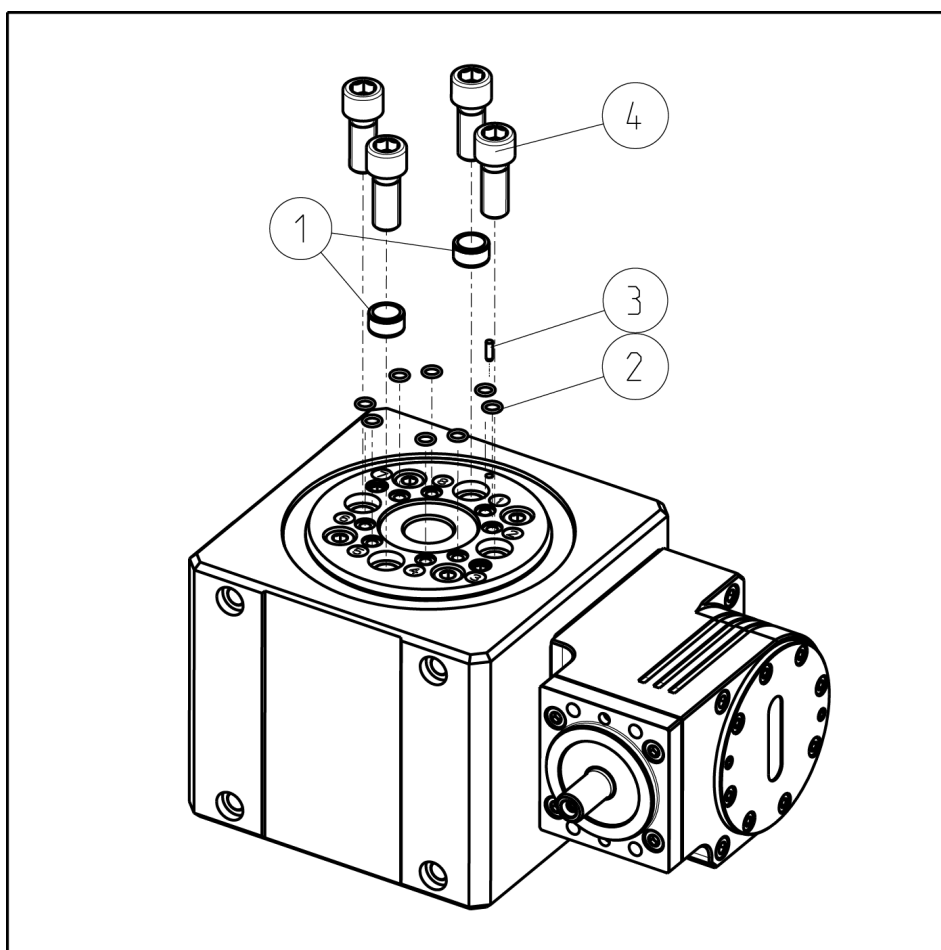

| Item | Description | Included in scope of delivery | Not included in scope of delivery |
|------|--------------------------|-------------------------------|-----------------------------------|
| 1 | Centering sleeves Ø16 | x | |
| 2 | O-rings | x | |
| 3 | Cylindrical pin | | x |

| Item | Description | Included in scope of delivery | Not included in scope of delivery |
|------|-------------|-------------------------------|-----------------------------------|
| 4 | Screws | | X |

1. Grease O-rings (2) and press them into the counterbores.
2. If provided, fit cylindrical pin (3) (for the index bore hole) on the attachments.
3. Fasten attachments to the output flange using four M12 screws (4).

Connection of the media feed-through

The rotary module has – depending on the version – eight feed-throughs for compressed air (oiled, up to 8 bar). Other media should be clarified with technical sales.

The connections are consecutively numbered on the output flange and the distributor flange.

The channels for connection 1 and connection 8 are on the outside, with channel 1 on the distributor flange side, and channel 8 on the output flange side.

On output flange

1. Connect the media feed-through using a hose-free direct connection.
2. Use O-rings (2) from the accessory pack. Fit O-rings in the connections that are not used to prevent liquid from getting into the bore holes.

On distributor flange

1. Connect the media feed-through either using screw-in plugs G1/8 or a hose-free direct connection.
 - ⇒ Screw-in plugs and O-rings are not included in the scope of delivery.
 - The recommended geometry of the O-ring counterbores for the hose-free direct connection can be found in the catalog.
2. Close off the connections that are not used with screw-in plugs or O-rings to prevent liquids from getting into the bore hole.

6.4 Electrical connection



⚠ WARNING

Risk of injury from electric shock due to contact with live parts!

- Observe the motor operating manual.
- Before conducting any work on the machine and peripheral equipment, disconnect them from the power supply (load and logic voltage) and secure against accidental activation.
- Wait until the frequency converter/controller is discharged.

NOTE

- Observe the maximum electrical energy values (☞ motor operating manual).
- Connect the motor to the machine.
Follow the instructions from the operating manual for the motor.



⚠ WARNING

Risk of injury due to sudden movements!

Is the energy supply is switched on, this can cause components to move unexpectedly, which may result in serious injuries.

- Disconnect power sources before installation and calibration.
- Only allow qualified electricians to perform any work on electrical components.

7 Start-up



⚠ WARNING

Risk of injury due to sudden and unexpected movement of the machine/system!

When the energy supply fails or the components malfunction, parts may move unexpectedly and cause severe injuries.

- Only expert personnel may carry out start-ups.
- Ensure that the danger zone (rotation of the add-on parts by a full 360°) is enclosed by protective fencing during operation.
- Exercise particular caution during start-up (selection of movement and control parameters, setting of drive limits, caution during cabling and wiring).
- Exercise particular caution when restarting after motor/controller reference loss or after disassembly of the attachments/module from the machine. Provide acknowledgment of the error message after a reference loss.
- Take any additional movements and forces acting on the rotary module from outside into account.
- Avoid an uncontrolled emergency stop (for example, application of the holding brake during movement). The motor holding brake is not suitable for an emergency stop.
- Operation in EMC-safe environment and in a suitable environment in accordance with specified protection class, ▶ 3 [19].
- Avoiding jamming (e. g. due to presence of large interfering particles between the attachments and the rotary module housing) or impacts on interfering contours.
- Avoid thermal overload in the motor.
- Observe the position and direction of rotation.



⚠ WARNING

Risk of injury due to moving parts coming into proximity with stationary parts!

Moving components may cause severe injuries. Body parts may get crushed and bruised.

- Ensure that the danger zone is enclosed by protective fencing during operation.
- Exercise particular caution during start-up.

7.1 Adjusting the movement and control parameters, and the exact limits in the controller

NOTICE

Overloading of the rotary module components due to angular momentum during emergency stop with holding brake possible, due to excessive input torques or collision with machine components.

- Operation by qualified personnel only.
- Avoid overshoot by observing the recommended acceleration.
- Only operate the motor holding brake when shut down.
- Define the behavior of the controller in case of faults (emergency stop with ramp).
- Reduce maximum motor torque or maximum acceleration for all acceleration, braking and stopping processes (including normal operation, operating stop, emergency stop etc.) ▶ 3 [19].
- Select a suitable motor.
- Check the entire movement range for interfering contours.
- Before starting, check the position and direction of rotation.

Start-up instructions

- For optimum use, the IndraDyns S MSK050B servo motor and the Indradrive C or Indradrive CS controllers from Bosch Rexroth or comparable servo motors and controllers are recommended (▶ 1.4 [7]). Other motor sizes can also be useful depending on the requirements and moment of inertia.
- Warming up the rotary module is mainly dependent on warming up the motor. The temperature of the motor may not exceed 100°C.
- Before commissioning, **all exact limits must first be set correctly in the controller** ▶ 3 [19] by qualified, experienced expert personnel.
- The motor torque should be limited to the specified maximum input torque.

Likewise, the maximum acceleration and the maximum speed of rotation must be limited.

Limiting the input torques without limiting the accelerations can lead to overshoot or follow-through of the loads. The same applies if incorrect exact limits are selected.

The exact limits for the accelerations can be taken from the diagrams depending on the moment of inertia of the attachments including the loads to be moved, provided the rotary module itself is not moved. If additional external accelerations are acting on the rotary module (e.g. due to linear movement of a gantry), these must also be taken into account when selecting the exact limits.

The speed of rotation must be further limited if the load can become too high even at lower speeds due to centrifugal forces.

- The SCHUNK sales team can provide support in calculating the movement parameters and exact limits.
- Be sure that the exact limits for the motor torque and the maximum acceleration for **all** possible stopping processes are correctly set, that is, both for normal operation and for all stopping processes triggered by faults.

Depending on the controller used, this may involve adjusting several exact limits. In addition, the behavior of the controller in the event of a fault must be adjusted so that a speed ramp with suitable acceleration is always used to bring the drive to a complete stop, before the holding brake is activated.

The holding brake is not suitable for the emergency stop. Depending on the effective braking torque of the holding brake, its misuse can result in damage to the rotary module.

If the holding brake has been actuated during movement, however, every individual holding position must immediately be checked for changes and re-adjusted if necessary. The module should also be immediately checked for damage and, if necessary, sent to SCHUNK Service.

- To ensure correct operation of the rotary module and to achieve the optimum life span, the control parameters must be set correctly based on the time responses of the position, speed, acceleration, and input torque (or motor current) variables. The optimum control parameters depend on the moments of inertia of the attachments, including the loads. For the recommended controller in conjunction with the MSK050B motor, the control parameters can be taken from the table. The specified parameters are only intended as a basis for further control optimization during start-up and only apply for operation in conjunction with a vertical rotational axis.

| Moment of inertia J [kgm ²] | Position controller Kv factor | Proportional speed amplification | Speed readjustment time |
|--------------------------------------------|----------------------------------|----------------------------------|-------------------------|
| 1 | 1 | 0.1 | 3 |
| 2 | 1 | 0.1 | 3.5 |
| 4 | 1 | 0.1 | 4 |
| 6 | 0.9 | 0.1 | 4.5 |
| 10 | 0.5 | 0.1 | 5.5 |
| 15 | 0.3 | 0.09 | 6.5 |
| 20 | 0.2 | 0.08 | 7.5 |

Tab.: Basic control parameters, vertical rotational axis

- We recommend selecting the acceleration and speed parameters in such a way that the torque or current limitation is not active, or only to a limited extent. Otherwise, the control quality can be impaired (vibrations, overshoot, etc.), even to the extent of critical faults in the control loop resulting in an emergency stop (with holding brake in some circumstances). If necessary, the fault limit in the controller should be adjusted.
- Warming up the rotary module is mainly dependent on warming up the motor. The temperature of the motor may not exceed 100°C.
- The rotary module is intended for operation with no stop in the end position.

Recommended acceleration

Our recommendation for the angular acceleration at a given mass moment of inertia of the attachments with a vertical axis or horizontal axis with central design can be found in the following diagrams.

Higher values cause a deterioration in the control behavior and can cause overloading of the module or damage to the overall system due to overshoot.

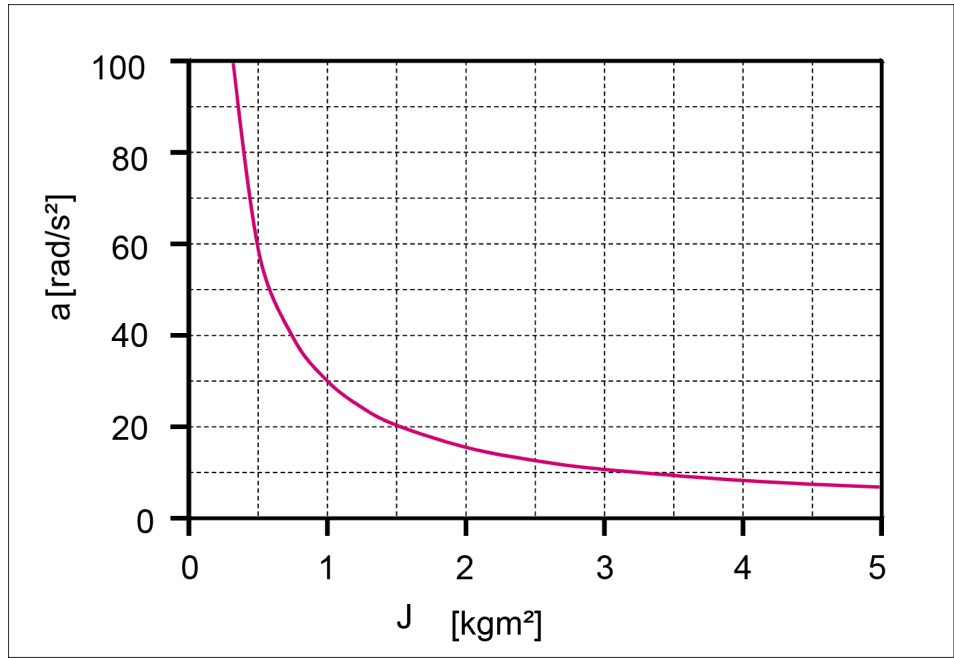

Recommended acceleration (moment of inertia up to 5kgm²)

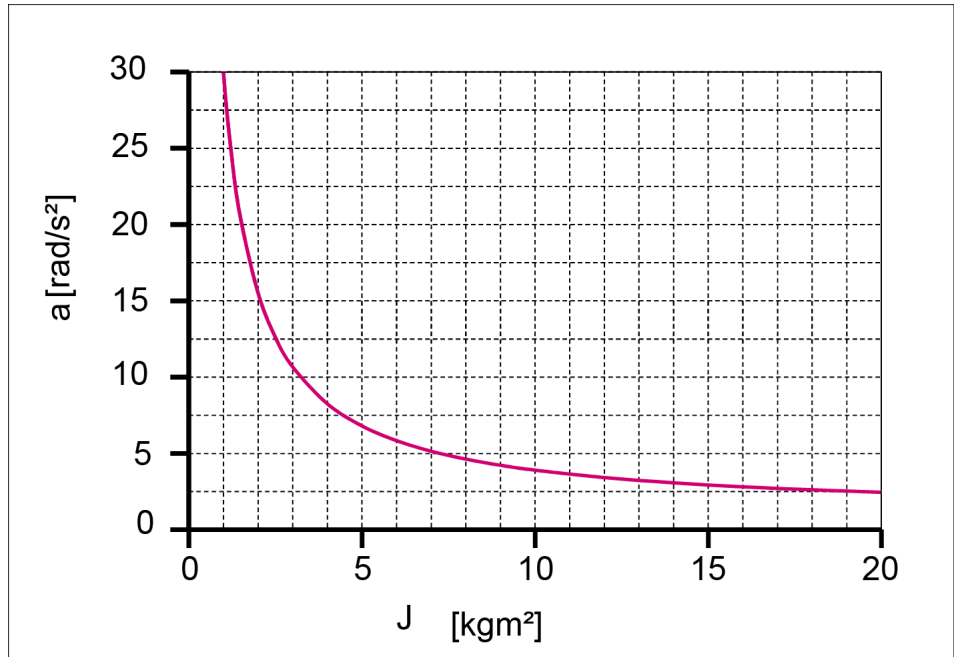

Recommended acceleration (moment of inertia up to 20kgm²)

8 Troubleshooting

8.1 Module does not move?

| Possible cause | Remedial measures |
|------------------------------------------------|-----------------------------------------------------------------------------------------------------------------------------------------------------------------------------------------------------------------------------------------------------------------------------------------------------|
| Motor not turning over. | Check electrical connection. Check parameters of the actuation: All current / torque limits, position reference, assigned motor, transmission specifications, units of measure, position setpoints, rest periods, fault memory, fault acknowledgment. Check actuation hardware and software. |
| Motor turning over, output not turning over. | Check that the motor add-on kit is installed correctly. |
| A component is broken e.g. due to overloading. | Send the product to SCHUNK with a repair order. Make sure that the product was only used in the context of its defined application parameters. ▶ 3 [19] |
| Component jammed. | Check idle torque without motor. If necessary, send the module to SCHUNK with a repair order. Make sure that no chips or contamination is getting into the bearings during maintenance of the radial shaft sealing rings. |

8.2 Does the module not provide the correct rotating angle?

| Possible cause | Remedial measures |
|-----------------------------------------------------|----------------------------------------------------------------------------------------|
| End positions are adjusted incorrectly. | Check position setpoints in actuation. |
| Position reference incorrectly adjusted. | Check the position reference and re-reference if required. |
| Incorrect actuation parameters selected. | Check parameters of the actuation: transmission, units, stored motor. |
| Components have come loose e.g. due to overloading. | Check the motor add-on kit components. Send the product to SCHUNK with a repair order. |
| Actuation defective. | Check actuation hardware and software. |

8.3 Torque drops

| Possible cause | Remedial measures |
|----------------------------------------------------------|-------------------------------------------------------------------------------------------------------------------------------------------------|
| Motor defective | Check the motor. |
| Actuation defective | Check actuation hardware and software. |
| Idle torque below minimum. | Check all current / torque limits in the actuation. |
| Bearing defective, serration defective, dirt penetrated. | Send the module to SCHUNK with a repair order. Make sure that the module has only been used within its defined application parameters. ▶ 3 [19] |

8.4 Does module rotate jerkily or overshoot end position?

| Possible cause | Remedial measures |
|-----------------------------------------------------|-------------------------------------------------------------------------------------------------------------------------------------------------------------------------------------------------------------|
| Incorrect actuation parameters selected. | Follow the start-up instructions. Reduce the acceleration. Check parameters of the actuation: Current/torque limit, control parameters (position and current). Reduce the current pre-amplification factor. |
| Application has changed. | Make sure that separate parameter sets are used for applications that differ significantly (particularly high moments of inertia). |
| Tooth clearance increased | Check the tooth clearance. Send the module to SCHUNK with a repair order. Make sure that the module has only been used within its defined application parameters, ▶ 3 [19]. |
| Components have come loose e.g. due to overloading. | Check the motor add-on kit components. Send the module to SCHUNK with a repair order. |

8.5 Does module overshoot significantly at end positions?

| Possible cause | Remedial measures |
|------------------------------------------|------------------------------------------------------------------------------------------------------------------------------------------------------------------------------------------------------------------------------------------------------------------------------------------------------------------------------------------------------------------------------------------------|
| Incorrect actuation parameters selected. | <p>Check the parameters.</p> <p>Check whether the correct parameter set for the application has been selected.</p> <p>Follow the start-up instructions.</p> <p>Check the current / torque limit.</p> <p>Reduce the acceleration relative to the current / torque limit.</p> <p>Adjust the exact limit for faults (position value deviation).</p> <p>Adjust the behavior in case of faults.</p> |
| Application has changed. | Make sure that separate parameter sets are used for applications that differ significantly (particularly high moments of inertia). |

8.6 Is module turning too quickly / too slowly?

| Possible cause | Remedial measures |
|------------------------------------------|------------------------------------------------------------------------------------------------------|
| Incorrect actuation parameters selected. | Check parameters of the actuation: Speed limit, transmission, assigned motor, current / torque limit |

9 Maintenance



⚠ WARNING

Risk of injury due to improperly carried out maintenance work!

Improperly carried out maintenance work can lead to severe injuries and significant property damage.

- Before beginning all work, secure machine/system from switching back on again.
- Perform maintenance work outside the danger zone.
- Take particular care during maintenance and disassembly.
- Only have expert personnel carry out all disassembly and maintenance work described in this operating manual. Disassembly beyond the degree described here may only be carried out by SCHUNK Service, otherwise the warranty expires, Warranty.

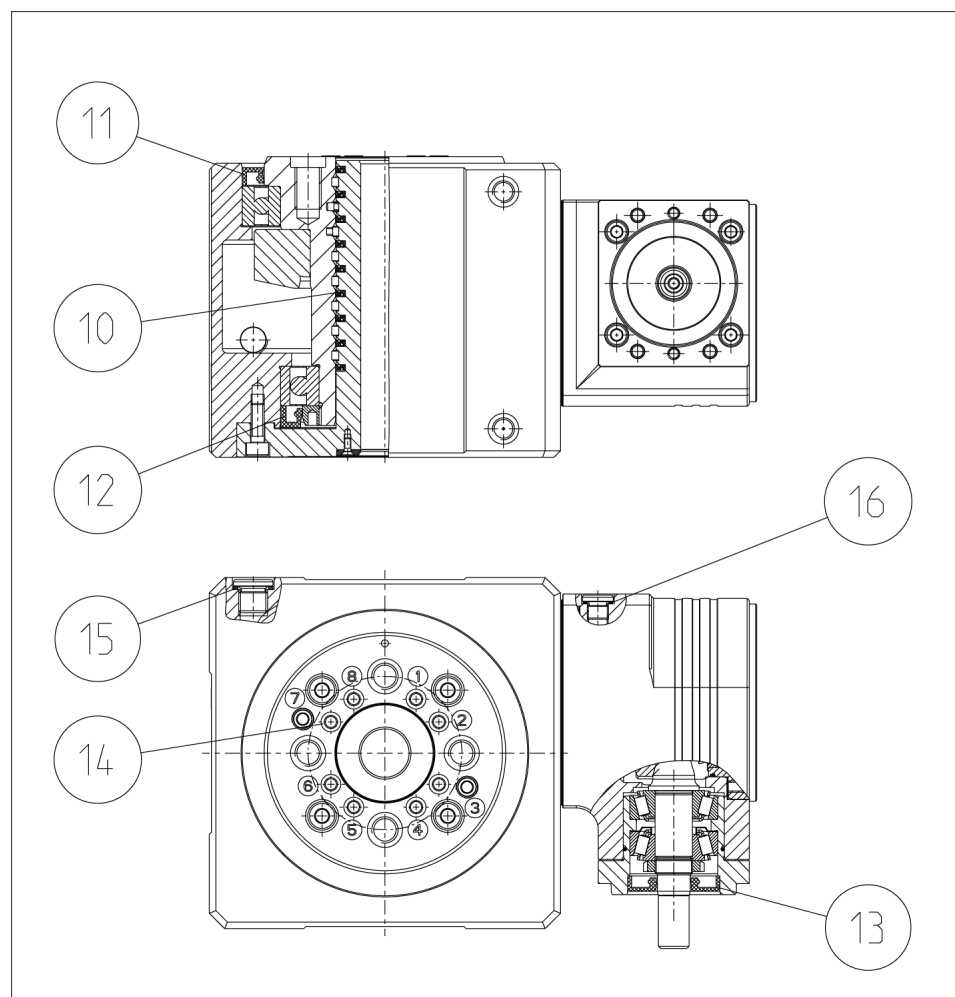

| Item | Designation |
|------|----------------------------------------|
| 10 | Piston seals on the media feed-through |

| Item | Designation |
|-------|---------------------------------------------------------------------|
| 11 | Radial shaft sealing ring on flange shaft (output flange side) |
| 12 | Radial shaft sealing ring on flange shaft (distributor flange side) |
| 13 | Radial shaft sealing ring on drive |
| 14 | O-rings for hose-free direct connection to output flange (optional) |
| 15/16 | Sealing disks on oil drain screws |

Radial shaft sealing rings

The life span of radial shaft sealing rings depends on many parameters and can therefore be predicted in practice only with great difficulty. For this reason, inspect the tightness with regular visual inspections. If any leaks are detected, have the corresponding radial shaft sealing ring changed by SCHUNK Service.

Maintenance overview

| Maintenance interval | Maintenance task | see |
|-------------------------|--------------------------------------------------|--------------------|
| Every 10 million cycles | Oil Change | ▶ 9.4 [49] |
| | Exchange radial shaft sealing rings (11,12,13) * | Brief introduction |
| Every 1 million cycles | Replacing the media feed-through seals (10) | ▶ 9.2 [43] |
| Regular | Check rotary module for leaks * | |

*) Note: SCHUNK recommends having the radial shaft sealing rings (11) and (12) on the flange shaft and the radial shaft sealing ring (13) on the drive replaced by SCHUNK Service if required. Replacing other seals fitted in the module is not normally necessary, and may only be carried out by SCHUNK Service.

Maintenance materials

| Assembly group | Product designation/ Ident number | Contents |
|--------------------|--------------------------------------------------|------------------------------------------------------------------------------------------------------------------------------------|
| Media feed-through | ERM 160-MDF sealing kit Ident number: 5522431 | <ul style="list-style-type: none"> Sealing kit (Piston seal (10), 9 piece, O-ring for air connection (14), 8 piece) |

| Assembly group | Product designation/ Ident number | Contents |
|----------------------------|----------------------------------------------------|--------------------------------------------------------------------------------------------------------------------------------------------------------------------------------------------------------------------------------------------------------------------------------------------------------------------|
| Radial shaft sealing rings | ERM 160-B sealing kit Ident number: 5522227 | <ul style="list-style-type: none"> ERM 160-B sealing kit (radial shaft sealing rings (11), (12) and (13), and sealing disks (15), (16)) Brief introduction |
| | Maintenance kit ERM 160-B Ident number: 5524004 | <ul style="list-style-type: none"> ERM 160-B sealing kit ERM 160-B disassembly kit (slide hammer, extension piece, and self-tapping screws, box of 50 pieces) ERM 160-B assembly kit (assembly stamp for radial shaft sealing rings (11), (12), (13)) Brief introduction |

NOTE

Store sealing kits in compliance with DIN 7716 (protect from light, heat, humidity, oxygen, and ozone, use moderate ventilation). Do not exceed specified storage times.

NOTICE

Never operate the rotary module without sufficient lubrication.

Tooth clearance

A slight increase in the tooth clearance within the specified exact limit while still complying with the specified exact limits for the input torque is possible and normal.

During operation, the tooth clearance can increase over the life span as shown in the diagram. If necessary, SCHUNK Service can reset the tooth clearance.

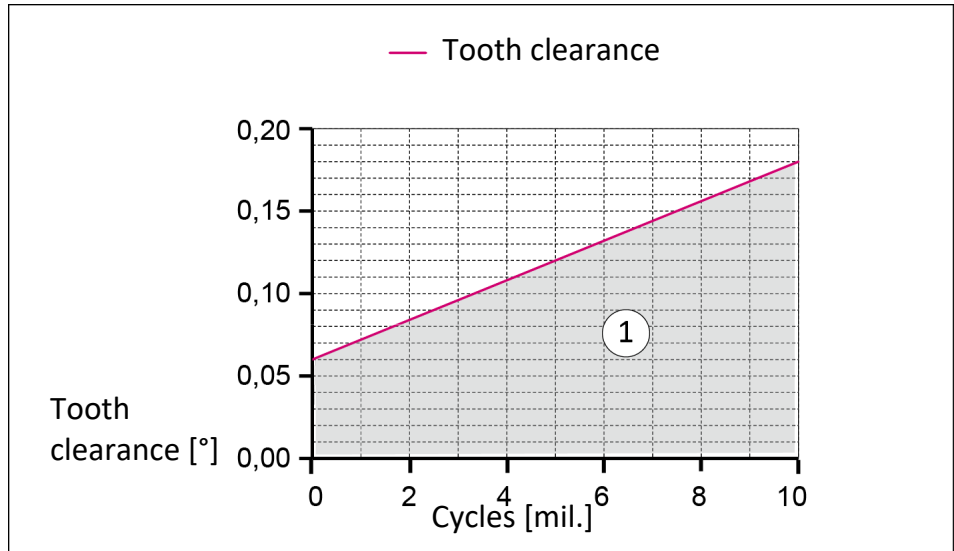

1 Area of the normal tooth clearance

9.1 Disassemble servo motor and motor adapter



⚠ WARNING

Risk of injury due to unexpected movement of the machine/system!

- Before conducting any work on the machine and peripheral equipment, disconnect them from the power supply (load and logic voltage) and secure against re-activation.
- Wait until the frequency converter/controller is discharged.
- Before starting any work on the machine and peripheral equipment, disconnect them from the compressed air and media connections.
- Wait until the compressed air reservoirs are discharged.
- Secure media lines against leakages.
- Before disassembly of the motor, remove workpieces and move the attachments to a suitable position with no potential residual energy. Alternatively, disassemble all eccentrically seated attachments or fit an external holding device for them.



⚠ WARNING

Risk of injury from falling objects!

- Caution during disassembly of components.
- Wear protective clothing during disassembly.

NOTE

- All actions in the above warning information must be carried out.

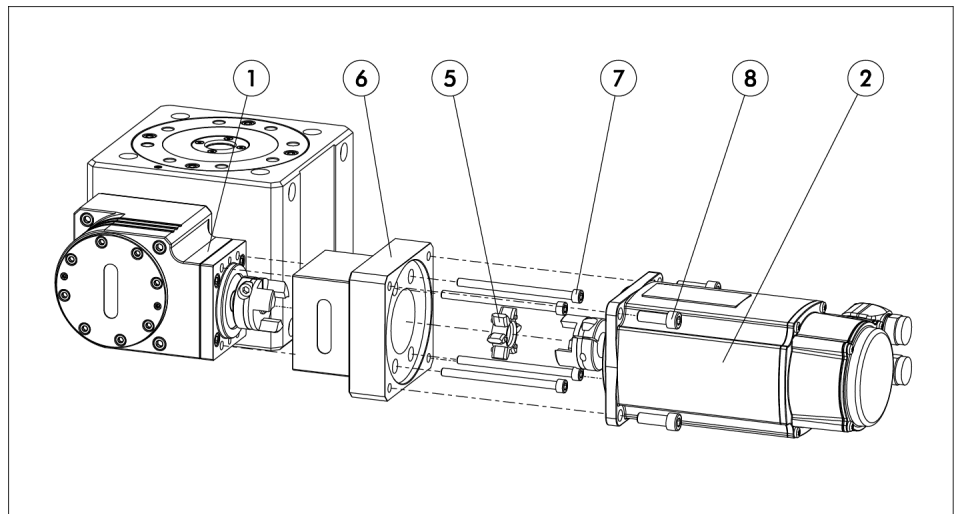

1. Move the attachments to a suitable position with no potential residual energy, secure using an external holding device, or disassemble.
2. Remove the mounting screws (8) on the motor adapter.
3. Detach the motor (2) from the motor adapter (6).
4. Remove the mounting screws (7).
5. Detach the motor adapter (6) from the rotary module (1).

9.2 Replacing the media feed-through seals



⚠ WARNING

Risk of injury due to unexpected movement of the machine/ system!

- Before starting any work on the machine and peripheral equipment, disconnect them from the power supply (load and logic voltage) and secure against re-activation.
- Wait until the frequency converter/controller is discharged.
- Before conducting any work on the machine and peripheral equipment, disconnect them from the compressed air and media connections.
- Wait until the compressed air reservoirs are discharged.
- Secure media lines against leakages.



⚠ WARNING

Risk of injury from falling objects!

- Caution during disassembly of components.
- Wear protective clothing during disassembly.

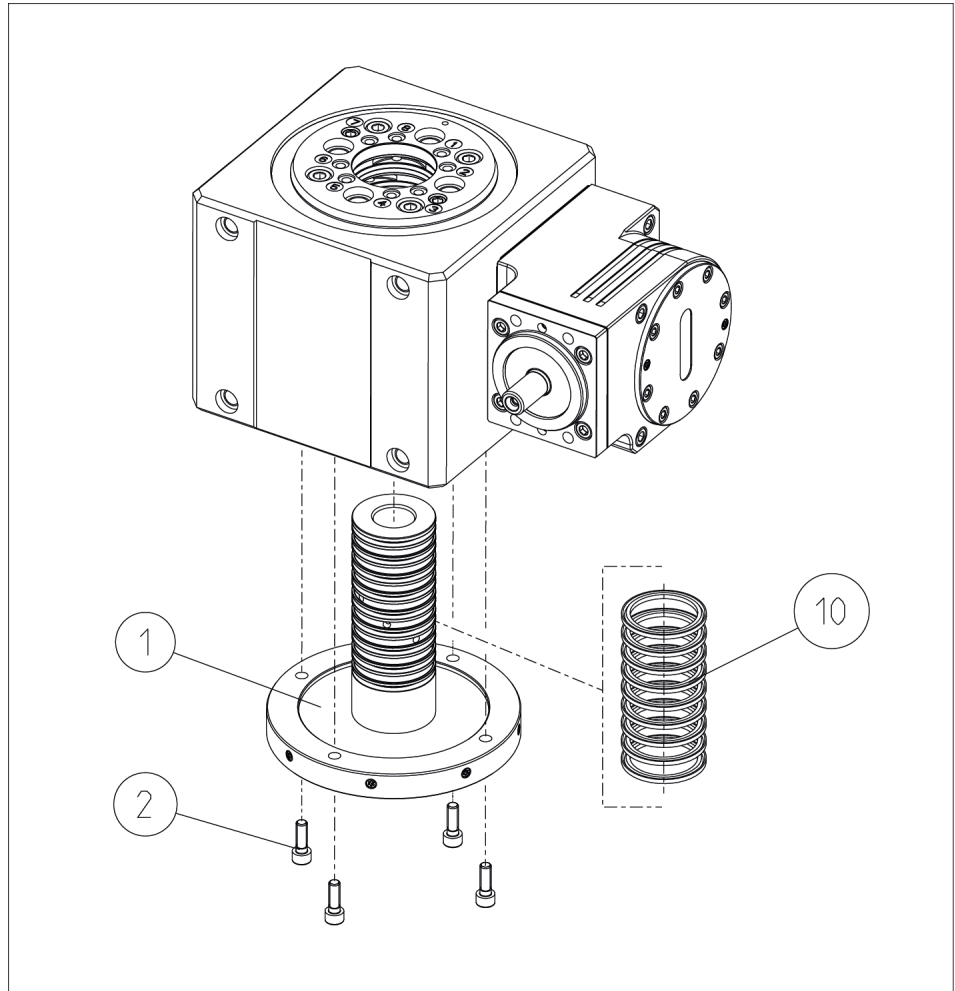

NOTE

A suitable assembly kit is available from SCHUNK ▶ 9 [40]. Refer to the instructions for assembly of the seals using the device.

1. Unscrew the four screws (2).
2. Carefully press distributor flange (1) from the opposite output side and then gradually remove it. Alternatively, carefully remove it using the G1/8 thread of the compressed air connections.
3. Disassemble all seals (10) for the rotary feed-through on the distributor flange.
4. Clean sealing grooves on the distributor flange of foreign bodies and lubricate with assembly grease.

5. Fit seals (10) in turn with a suitable device. It is essential to start with the seal closest to the flange.
6. Examine the radial shaft sealing ring for leaks and replace if necessary ▶ 9.5 [51].
7. Apply assembly grease to the seals.
8. Carefully slide distributor flange gradually back into the flange shaft by hand.
9. Clean the four screws (2).
10. Fasten distributor flange with the four screws. **Observe tightening torque of 10.1 Nm.**

9.3 Mount seals of the media feed-through with the assembly device ERM 160-MDF

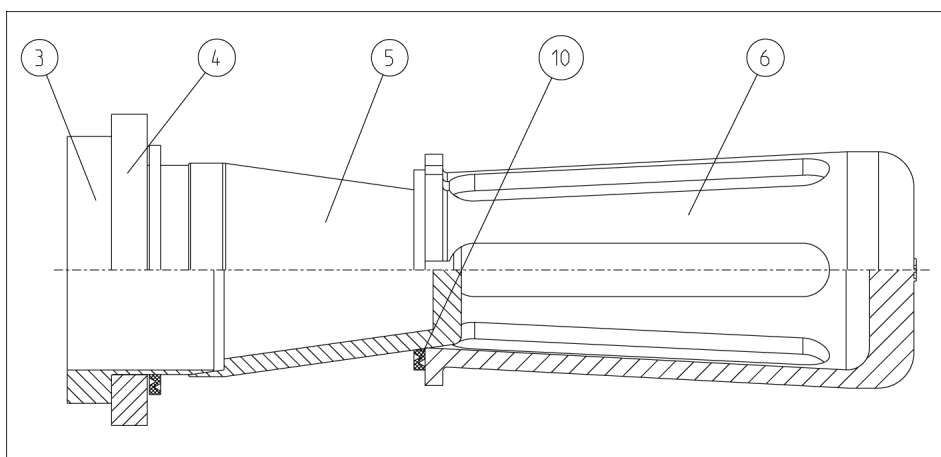

1. Slide the wiper ring (4) onto the assembly sleeve (3).
2. Fit the expanding mandrel (5) on the assembly sleeve (3).
3. Place the seal (10) on the expanding mandrel (5).
4. Slide the seal (10) with pressure sleeve (6) over the expanding mandrel onto the assembly sleeve.

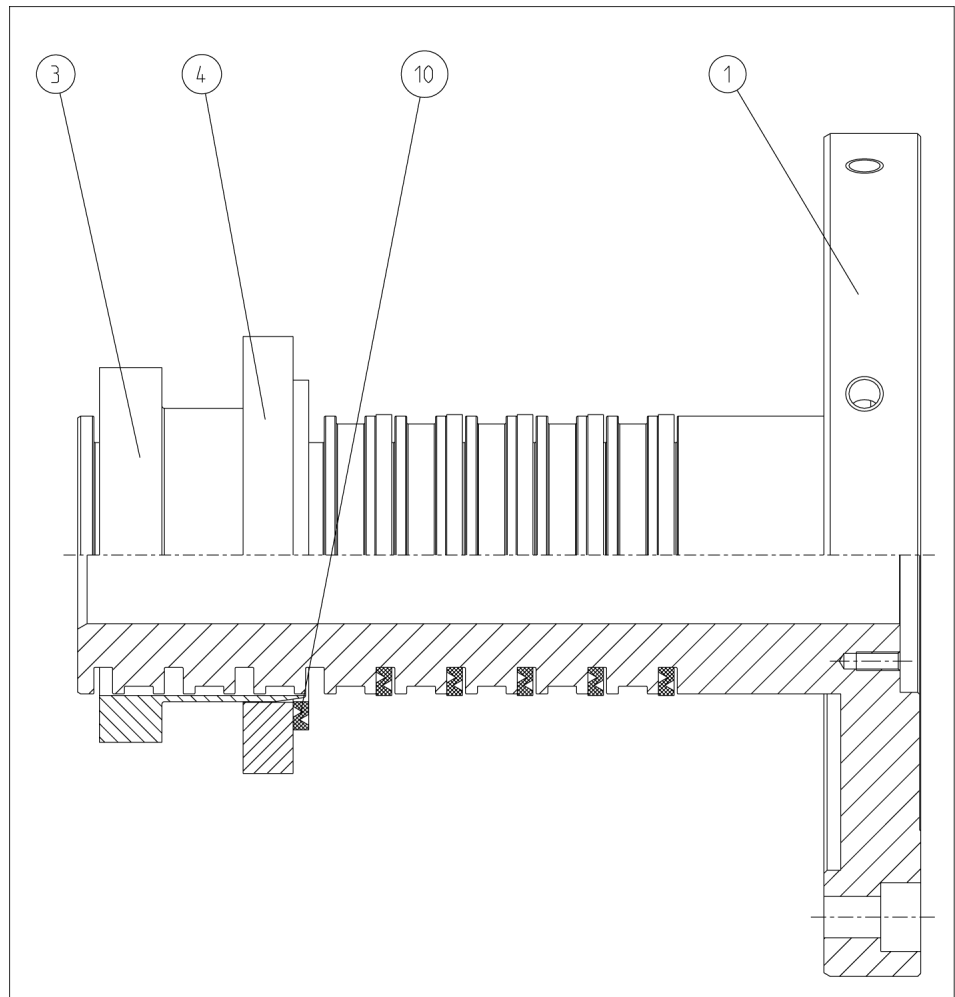

5. Slide the assembly sleeve (3) onto the distributor flange (1) until the end of the sleeve reaches the desired sealing groove.
6. Detach the seal (10) with wiper ring (4) from the assembly sleeve into the sealing groove.

NOTE

- When assembling, always start with the seal closest to the flange.
 - If only one seal is defective, all seals in front of it must also be replaced as otherwise they could be damaged by the assembly sleeve.
-

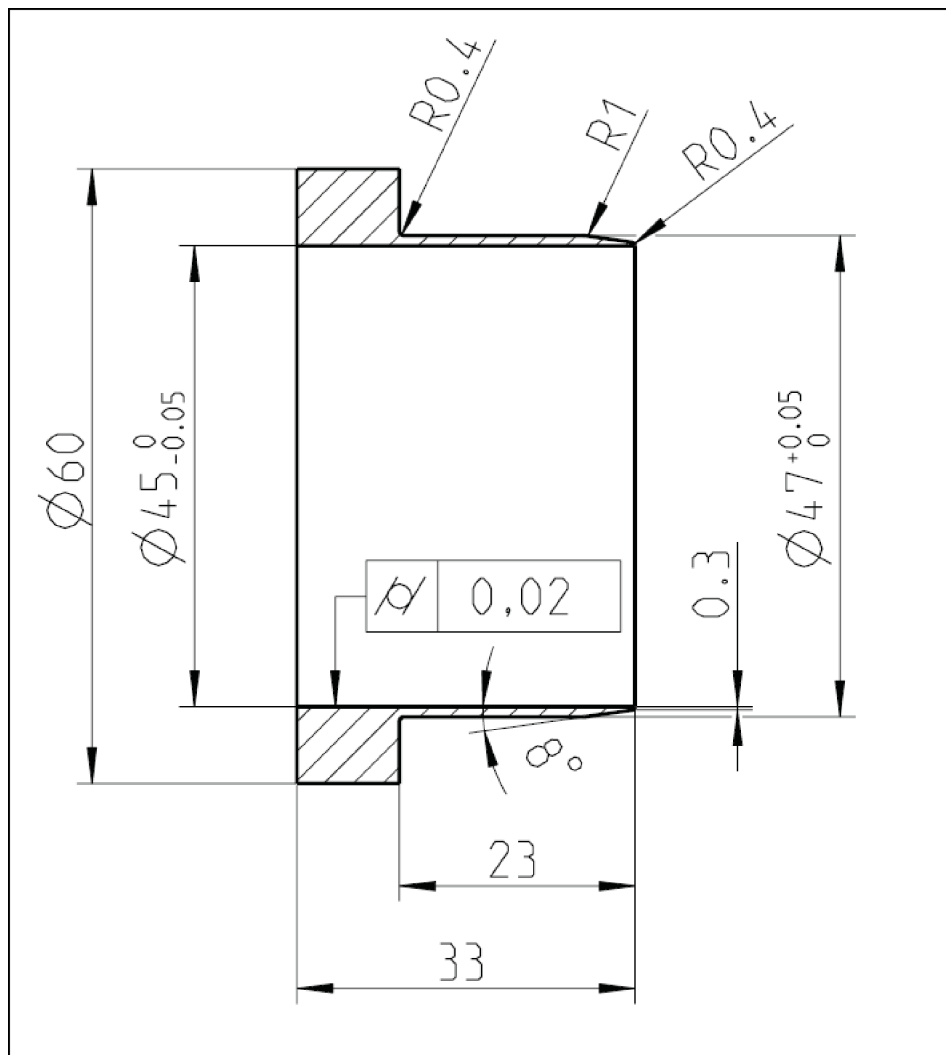

Assembly sleeve (4)

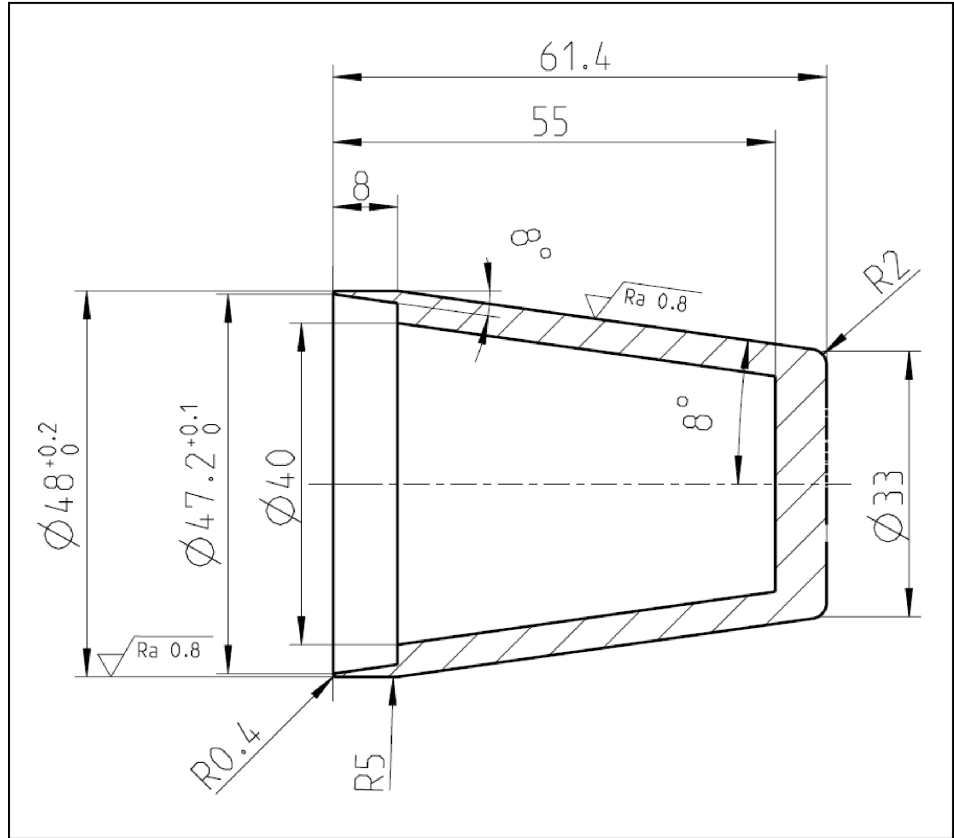

Expanding mandrel (6)

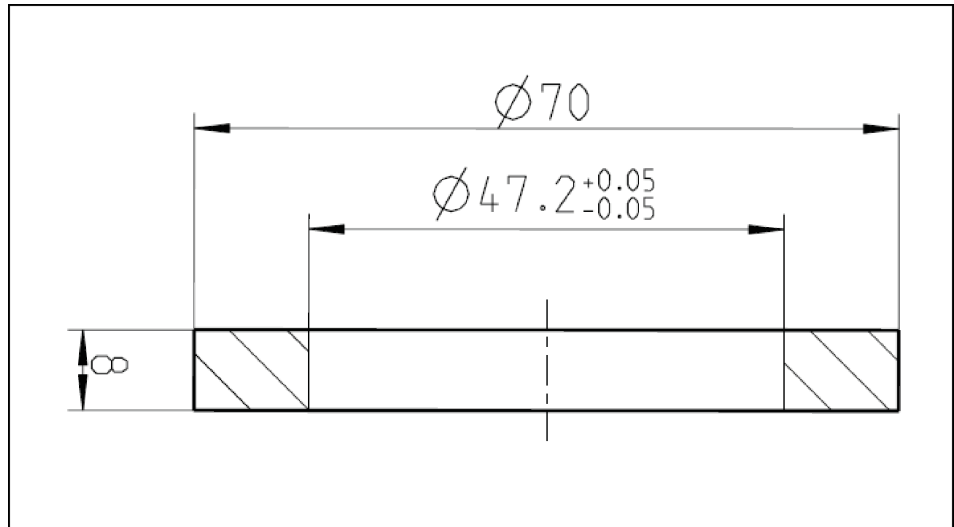

Wiper ring (5)

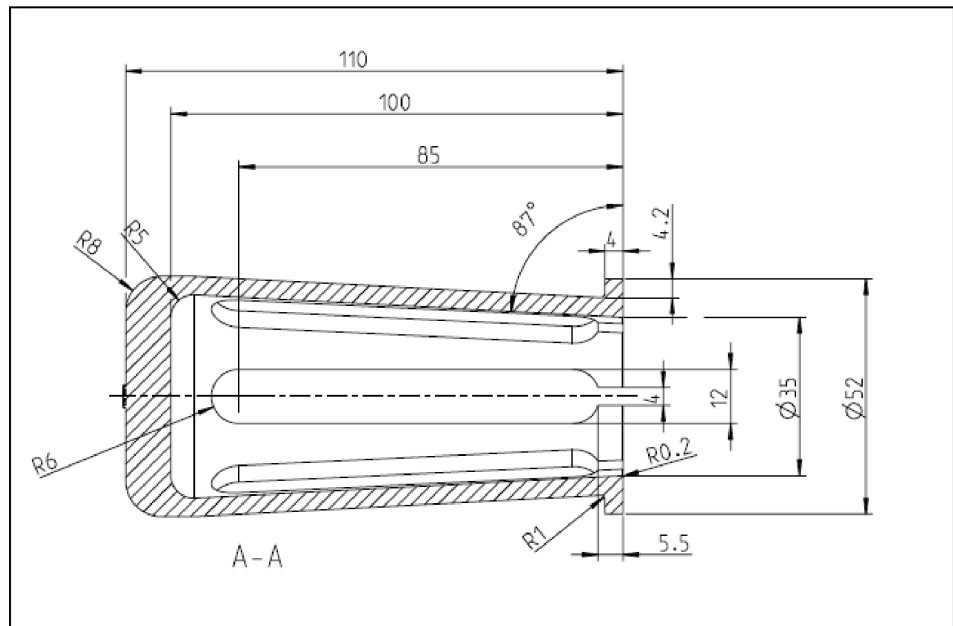

Pressure sleeve (7), material PA 6

9.4 Oil Change



⚠ CAUTION

Risk of injury due to leaking hydraulic oil!

Hydraulic oil may cause irritation if it comes into contact with the skin and eyes. If hydraulic oil leaks, this poses a danger of slipping.

- Avoid skin contact with hydraulic oil.
- Wear protective gloves and safety goggles.
- Properly remove spilled or leaking hydraulic oil immediately.



⚠ WARNING

Risk of burns due to contact with hot surfaces and hot oil!

- Prior to working on the product, allow it to cool down to at least 40°C.
- Measure the surface temperature before touching the product.
- Wear protective gloves.

NOTICE**Danger to the environment due to wrong handling of environmentally hazardous substances!**

The hydraulic liquid contains toxic substances. Wrong handling, especially in case of incorrect disposal, may result in serious environmental damage.

- Collect spilled or leaking hydraulic liquid instantly and properly.
- Have hydraulic liquid disposed by a specialized company.

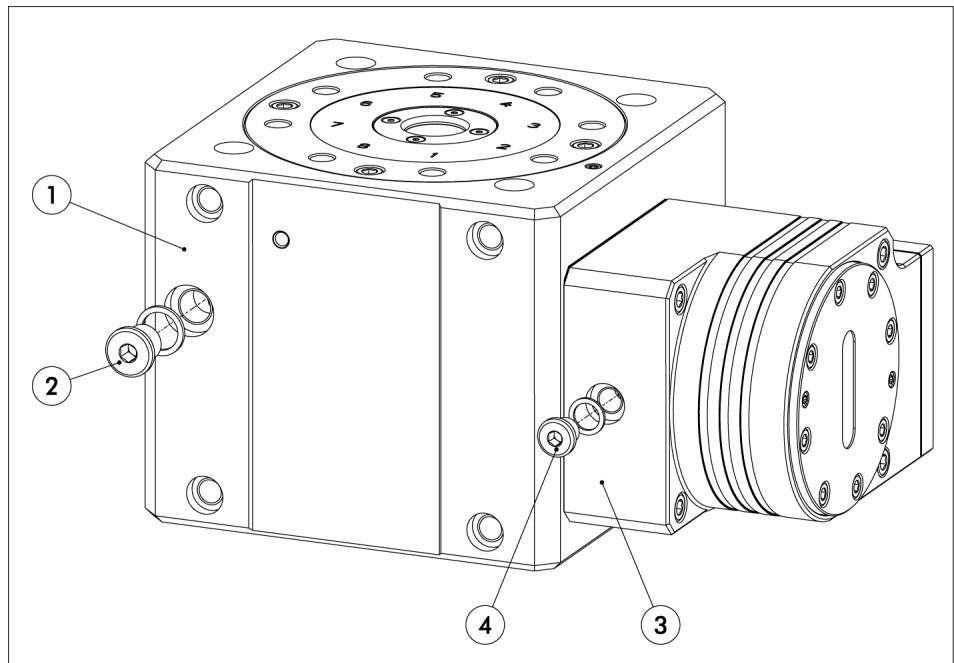

SCHUNK recommends the listed lubricant.

Oil to be used: Castrol Optigear PD150 ES *

* non-food-compliant lubricant

The module has two separate oil chambers

- Before an oil change, check the module for visible leaks and, if necessary, replace the radial shaft seals during the oil change, ▶ 9.5 [51].
 - Before the oil change, detach all attachments and remove the module from the gantry.
1. Place an oil trough underneath.
 2. Open the oil drain screw (2) and completely drain the oil from the main module (4).
 3. Fill the main module with new oil (about 500 ml).

4. Fit the drain screw (2) (G1/4) along with the sealing ring (tightening torque 24 Nm).
5. Open the oil drain screw (4) and completely drain the oil from the transmission (3).
6. Fill the transmission with new oil (approx. 60 ml).
7. Fit the drain screws (4) (G1/8) along with the sealing ring (tightening torque 14 Nm).
8. Dispose of the oil properly.

9.5 Replace radial shaft sealing rings

If oil is leaking from the rotary module, the radial shaft sealing rings must be replaced immediately. We recommend contacting the SCHUNK Service and having the radial shaft sealing rings replaced.

NOTICE

Property damage due to improperly carried out work!

If the radial shaft sealing rings are incorrectly replaced, components may become damaged. The warranty is void.

- Have radial shaft sealing rings replaced by SCHUNK Service.

Note: the replacement of the radial shaft sealing rings is described in a separate brief introduction.

10 Disposal



⚠ CAUTION

Risk of injury due to leaking hydraulic oil!

Hydraulic oil may cause irritation if it comes into contact with the skin and eyes. If hydraulic oil leaks, this poses a danger of slipping.

- Avoid skin contact with hydraulic oil.
- Wear protective gloves and safety goggles.
- Properly remove spilled or leaking hydraulic oil immediately.



⚠ WARNING

Risk of burns due to contact with hot surfaces and hot oil!

- Prior to working on the product, allow it to cool down to at least 40°C.
- Measure the surface temperature before touching the product.
- Wear protective gloves.

NOTICE

Danger to the environment due to incorrect handling of environmentally-hazardous materials!

Oils, lubricants and electronic components contain poisonous substances. If handled incorrectly, particularly when being disposed of, significant damage to the environment may result.

- Properly collect oils and lubricants immediately and have them removed by a specialist company.
- Have electronic components removed by a specialist company.

NOTE

Ensure proper disposal.

- Before disposal remove hydraulic oil using the two drain screws and dispose of properly.
- Follow the instructions for expert disposal in the motor and controller operating manuals.
- Pay attention to foreign substances due to operation during disposal.

1. Observe the locally valid legal disposal regulations.

2. Environmentally sound disposal via the corresponding recycling or workshop centers.
3. SCHUNK accepts no liability for the consequences of improper disposal by the customer.

Main components:

- Aluminum
- Steel
- Exterior parts chemically nickel plated
- Hydraulic oils, lubricating greases, adhesives (observe safety data sheet)
- Plastics

Motor:

- Steel, aluminum, copper, brass, magnetic materials
- Electronic components and assemblies

11 Translation of the original declaration of incorporation

in terms of the Directive 2006/42/EG, Annex II, Part 1 Section B.

Manufacturer/
Distributor SCHUNK SE & Co. KG
Spanntechnik | Greiftechnik | Automatisierungstechnik
Bahnhofstr. 106 – 134
D-74348 Lauffen/Neckar

We hereby declare that the partly completed machine described below

Product designation: Electric Rotary Module with Servo Motor / ERM /electric
ID number 0310550, 0310552

meets the following basic occupational health and safety of the Machinery Directive 2006/42/EC:

No. 1.1.1, No. 1.1.2, No. 1.1.3, No. 1.1.5, No. 1.3.2, No. 1.5.1, No. 1.5.2; No. 1.5.4, No. 1.5.6, No. 1.5.8, No. 1.5.10, No. 1.5.11, No. 1.5.13

The partly completed machinery may not be put into operation until it has been confirmed that the machine into which the partly completed machinery is to be installed complies with the provisions of the Machinery Directive (2006/42/EC). The declaration shall be rendered invalid if modifications are made to the product.

Applied harmonized standards, especially:

EN ISO 12100:2010 Safety of machinery – General principles for design –
Risk assessment and risk reduction

The special technical documentation according to Annex VII, Part B, belonging to the partly completed machine, has been created.

Person authorized to compile the technical documentation:
Stefanie Walter, Address: see manufacturer's address

Signature: see original declaration

Lauffen/Neckar, January 2025

Dr.-Ing. Manuel Baumeister,
Head of Systems Engineering,
Technology & Innovation

12 UKCA declaration of incorporation

in accordance with the Supply of Machinery (Safety) Regulations 2008.

| | |
|------------------------------|---------------------------------------------------------------------------------------------------------------|
| Manufacturer/ Distributor | SCHUNK Intec Limited Clamping and gripping technology 3 Drakes Mews, Crownhill MK8 0ER Milton Keynes |
|------------------------------|---------------------------------------------------------------------------------------------------------------|

We hereby declare that on the date of the declaration the following partly completed machine complied with all basic safety and health regulations found in the "Supply of Machinery (Safety) Regulations 2008".

The declaration shall be rendered invalid if modifications are made to the product.

| | |
|----------------------|----------------------------------------------------------|
| Product designation: | Electric Rotary Module with Servo Motor / ERM / electric |
| ID number | 0310550, 0310552 |

The partly completed machine may not be put into operation until it has been confirmed that the machine into which the partly completed machine is to be installed complies with the provisions of the "Supply of Machinery (Safety) Regulations 2008".

Applied harmonized standards, especially:

| | |
|-------------------|---------------------------------------------------------------------------------------------|
| EN ISO 12100:2010 | Safety of machinery – General principles for design – Risk assessment and risk reduction |
|-------------------|---------------------------------------------------------------------------------------------|

The special technical documentation according to Annex VII, Part B, belonging to the partly completed machine, has been created.

Person authorized to compile the technical documentation:
Marcel Machado, address: refer to manufacturer's address



Lauffen/Neckar, January 2025

Dr.-Ing. Manuel Baumeister,
Head of Systems Engineering,
Technology & Innovation

13 Information on the RoHS Directive, REACH Regulation and Substances of Very High Concern (SVHC)

RoHS Directive

SCHUNK products are classified as "large-scale stationary installations" or as "large-scale stationary industrial tools" within the meaning of Directive 2011/65/EU and its extension 2015/863/EU "on the restriction of the use of certain hazardous substances in electrical and electronic equipment (RoHS)", or fulfill their intended function only as part of one. Therefore products from SCHUNK do not fall within the scope of the directive at this time.

REACH Regulation

Products from SCHUNK fully comply with the regulations of Regulation (EC) No. 1907/2006 "concerning the Registration, Evaluation, Authorization and Restriction of Chemicals (REACH)" and its amendment 2022/477. SCHUNK attaches great importance to completely avoiding chemicals of concern to humans and the environment wherever possible.

Only in rare exceptional cases do SCHUNK products contain SVHC substances on the candidate list with a mass content above 0.1%. In accordance with Article. 33 (1) of Regulation (EC) No. 1907/2006, SCHUNK complies with its duty to "communicate information on substances in articles" and lists the components concerned and the substances used in an overview that can be viewed at [schunk.com\SVHC](https://www.schunk.com/SVHC).

Signature: see original declaration

Lauffen/Neckar, January 2025

Dr.-Ing. Manuel Baumeister,
Head of Systems Engineering,
Technology & Innovation

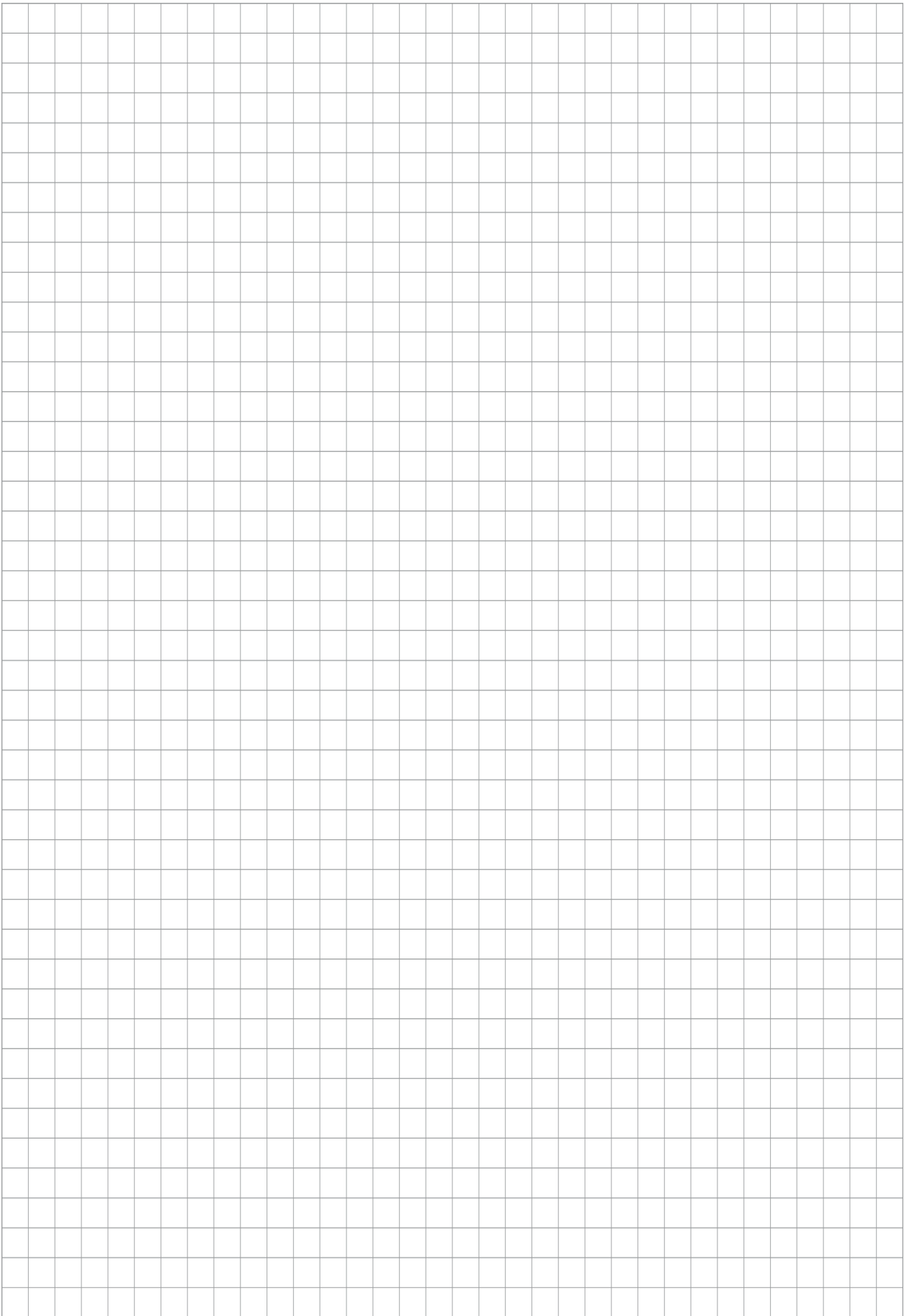

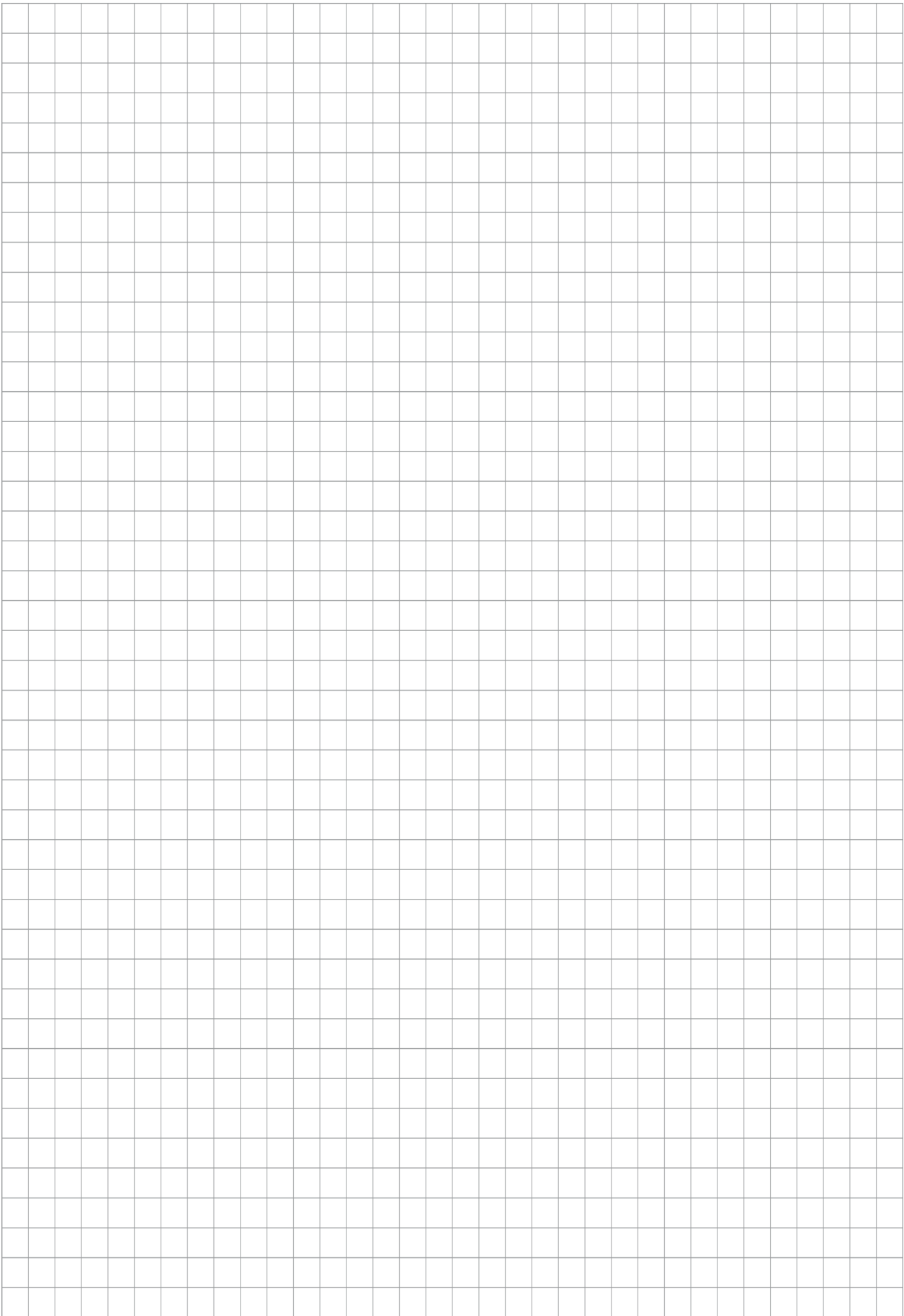

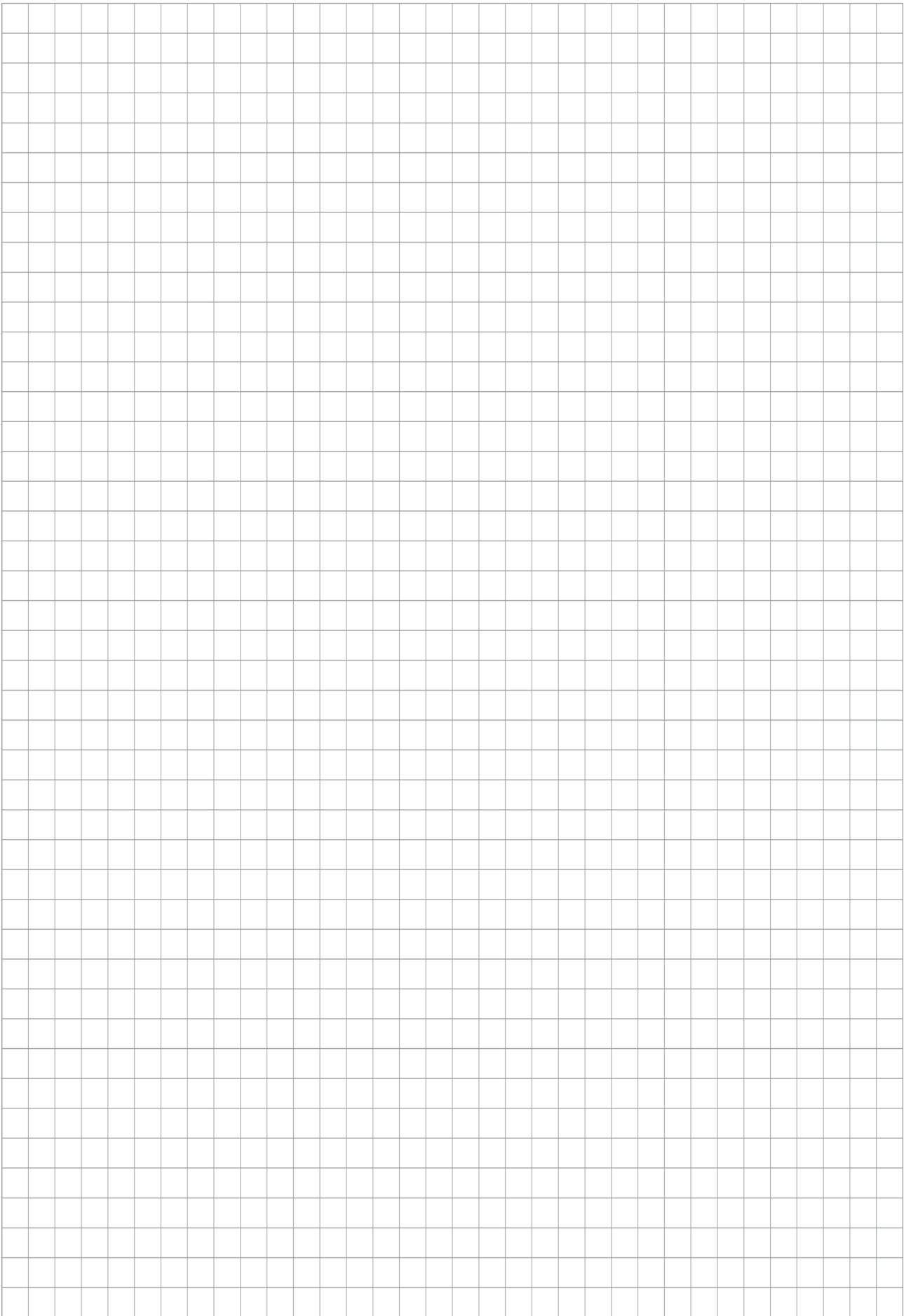



SCHUNK SE & Co. KG
Spanntechnik | Greiftechnik | Automatisierungstechnik

Bahnhofstr. 106 - 134
D-74348 Lauffen/Neckar
Tel. +49-7133-103-0
info@de.schunk.com
schunk.com

Folgen Sie uns | *Follow us*



Wir drucken nachhaltig | *We print sustainable*