

Electric Tool Changer EWS

Assembly and operating manual

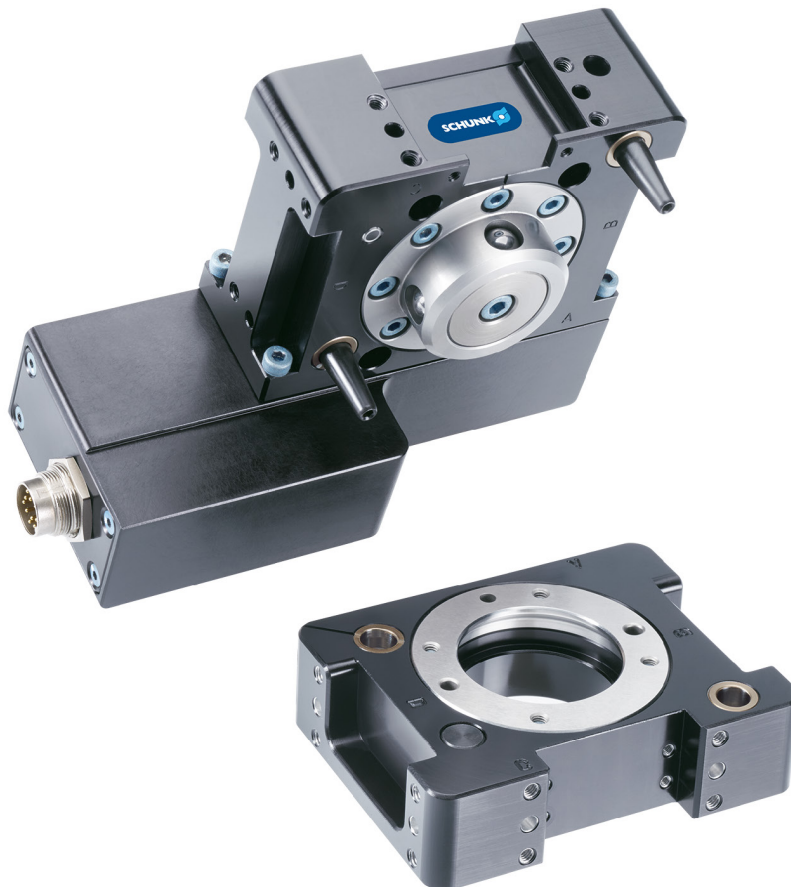

Imprint

Copyright:

This manual remains the copyrighted property of SCHUNK GmbH & Co. KG. It is solely supplied to our customers and operators of our products and forms part of the product. This documentation may not be duplicated or made accessible to third parties, in particular competitive companies, without our prior permission.

Technical changes:

We reserve the right to make alterations for the purpose of technical improvement.

Document number: 0389700

Edition: 02.02 |06/03/2017|en

© SCHUNK GmbH & Co. KG

All rights reserved.

Dear customer,

congratulations on choosing a SCHUNK product. By choosing SCHUNK, you have opted for the highest precision, top quality and best service.

You are going to increase the process reliability of your production and achieve best machining results – to the customer's complete satisfaction.

SCHUNK products are inspiring.

Our detailed assembly and operation manual will support you.

Do you have further questions? You may contact us at any time – even after purchase.

Kindest Regards

Yours SCHUNK GmbH & Co. KG

Spann- und Greiftechnik

Bahnhofstr. 106 – 134

D-74348 Lauffen/Neckar

Tel. +49-7133-103-0

Fax +49-7133-103-2399

info@de.schunk.com

www.schunk.com



Reg. No. 003496 QM08



Reg. No. 003496 QM08

Inhaltsverzeichnis

1	Product Overview	4
1.1	Quick Change Master (EWK).....	4
1.2	Quick Change Adapter (EWA).....	7
1.3	Servo Motor Module	8
1.4	Optional Modules	9
2	Installation.....	10
2.1	Quick Change Master Interface	11
2.2	Quick Change Master Installation	13
2.3	Quick Change Master Removal	14
2.4	Quick Change Adapter Interface	15
2.5	Quick Change Adapter Installation.....	17
2.6	Quick Change Adapter Removal.....	18
2.7	Electrical Connections	18
2.8	Lock Actuation Speed DIP Switch Settings.....	20
3	Operation	21
3.1	Conditions for Coupling.....	23
3.2	Fail-Safe Operation	25
3.3	Conditions for Uncoupling	26
3.4	Tool Storage Considerations	26
4	Maintenance.....	28
4.1	Preventive Maintenance	29
4.2	Cleaning and Lubrication of the Locking Mechanism and Alignment Pins.....	30
4.3	Pin Block Inspection and Cleaning.....	32
5	Troubleshooting and Service Procedures	34
5.1	Troubleshooting Procedures	34
5.1.1	Unit will not lock or unlock?	34
5.1.2	Loss of Communication?.....	35
5.2	Manual Lock and Unlock	36
5.3	Service Procedures	37
5.3.1	V-ring Seal Replacement.....	37
5.3.2	Alignment Pin Replacement	38
5.3.3	Servo Motor Module Replacement	39
6	Serviceable Parts	41
6.1	Quick Change Master (EWK).....	41
6.2	Quick Change Adapter (EWA).....	41
7	Specifications.....	42
8	Translation of original declaration of incorporation.....	43

1 Product Overview

The EWS Electric Tool Changer consists of a Quick Change Master and Quick Change Adapter.

	⚠ CAUTION
	<p>Do not use the EWS Electric Tool Changer in an application where water is present or other fluids are being passed. Using the Electric Tool Changer in an application where water is present or other fluids are being passed, can cause injury to personnel and damage to equipment.</p>

	⚠ DANGER
	<p>This module has a voltage of 50 V or greater, NO contact should be attempted before removing power. This especially includes separation or insertion of the mating connectors or any contact with the Electric Tool Changer or its components. Arcing and damage will occur if this is not observed. Remove power before attaching, disconnecting any cables or attempting any maintenance of Electric Tool Changer.</p>

1.1 Quick Change Master (EWK)

The Quick Change Master EWK includes an anodized aluminum body, a hardened stainless steel locking mechanism, and hardened steel alignment pins. The EWK has (4) Flats, Flat A is specifically for mounting the servo motor module. Flat C supports both K series modules and optional modules with J16 mounting patterns. Flats B and D support optional modules with J16 mounting patterns.

The servo motor module has an integrated controller and high torque motor. Refer to Section [\(1.3, Page 8 \)](#) for more details.

A PNP DC proximity sensor is designed into the body of the EWK to verify EWA presence when coupled. The sensors provide a ready-to-lock (RTL) signal through the control/signal module.

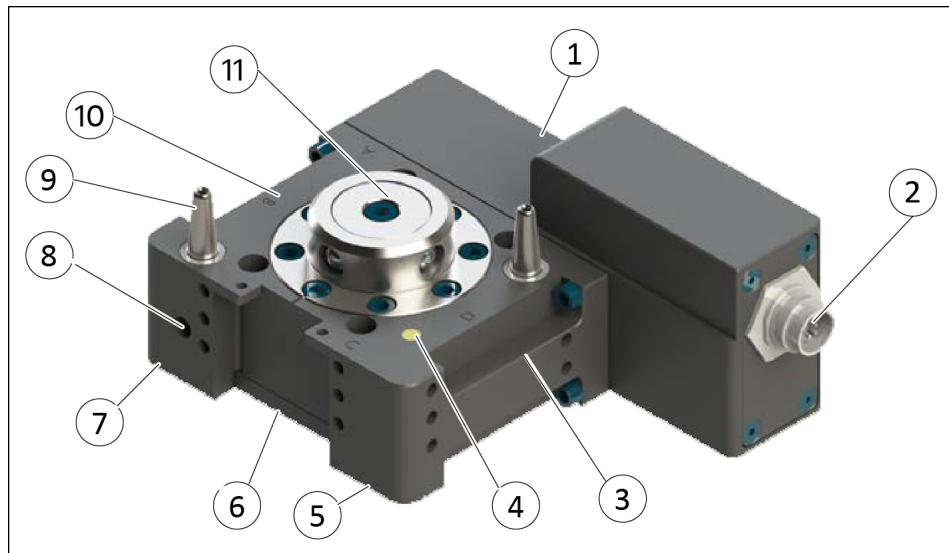

Quick Change Master with Servo Motor Module

1	Servo Motor Module Mounted to Flat A
2	12-Pin M12 Motor Control and Power Connector
3	Flat D for Option Module with J16 Mounting Patterns
4	RTL Proximity Sensor
5	Anodized Aluminum Body
6	Flat C for K Series Modules or Modules with J16 Mounting Patterns
7	EWK-018 Base Assembly
8	Manual Override for Locking Mechanism
9	Alignment Pins
10	Flat B for Option Module with J16 Mounting Patterns
11	Locking Mechanism

The EWK provides a mounting pattern with two dowel pins for locating the EWK and includes mounting fasteners (four M4 socket head cap screws).

PNP DC Proximity sensors are designed into the body of the EWK to verify the lock/unlock position of the locking cam. The sensors provide the lock and unlock (L/U) signals through the motor controller.

The locking mechanism consists of a male coupling with holes that retain hardened chrome-steel balls. A hardened stainless-steel cam is gear driven by a 24 V brushless DC servo motor. Tapered pins located on the EWK body mate with holes in the Tool body to ensure repeatable alignment during the coupling process.

An extreme pressure grease is applied to the cam, male coupling, ball bearings, and pins to enhance performance and maximize the life of the EWK assembly.

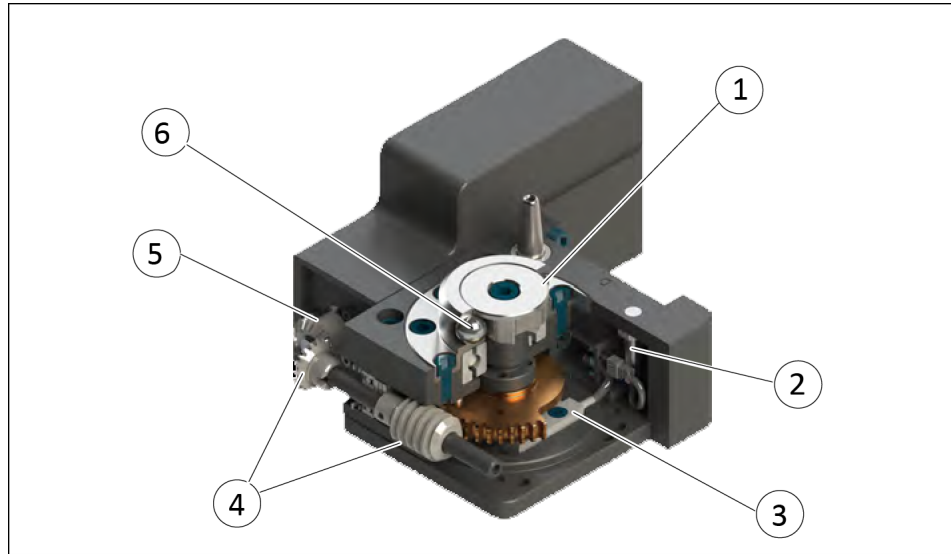

Locking Mechanism

1	Hardened Stainless-steel Cam
2	RTL Proximity Sensor
3	Lock and Unlock Proximity Sensors
4	Gear Driven Locking Mechanism
5	2 Amp 24V Brushless DC Servo Motor
6	Hardened Chrome-steel Balls
7	Hardened Stainless-steel Male Coupling

1.2 Quick Change Adapter (EWA)

The Quick Change Adapter EWA includes an anodized aluminum body, a hardened stainless-steel bearing race, and hardened steel alignment bushings. A sensor target is built into the Tool body for the RTL proximity sensor in the Quick Change Master EWK body can sense the Tool presence.

The EWA has four flats, flat A is not used for mounting modules because the servo motor module on the EWK requires the space a module would occupy. The Flat C supports both K series modules and optional modules with J16 mounting patterns. Flats B and D support optional modules with J16 mounting patterns.

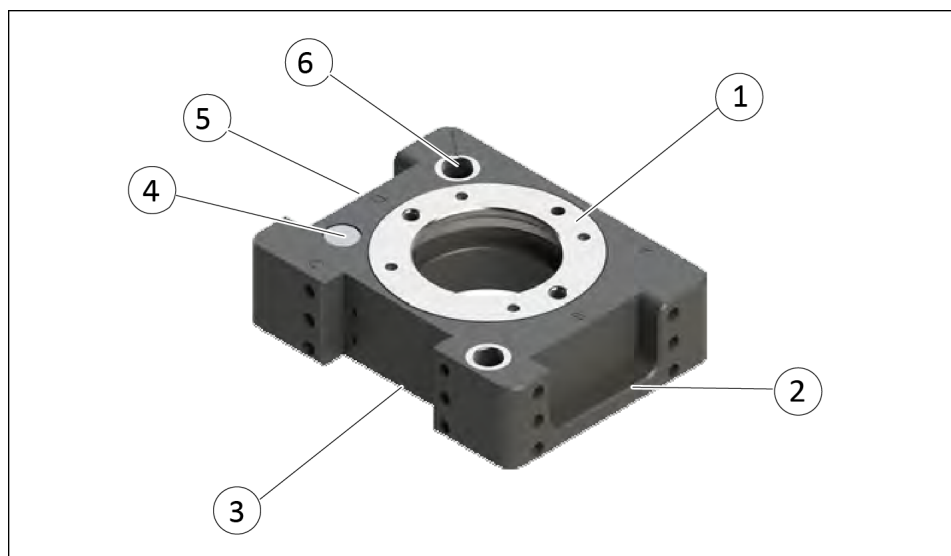

Quick Change Adapter

1	Hardened Stainless-steel Bearing Race
2	Flat B for Option Module with J16 Mounting Patterns
3	Flat C for K Series Modules or Modules with J16 Mounting Patterns
4	RTL Sensor Target
5	Flat D for Option Module with J16 Mounting Patterns
6	Alignment Bushings

1.3 Servo Motor Module

The Servo Motor Module has an integrated motor controller and a 24VDC brushless servo motor with sensor feedback. The module is equipped with a 12-Pin M16 connector to interface with a customer cable.

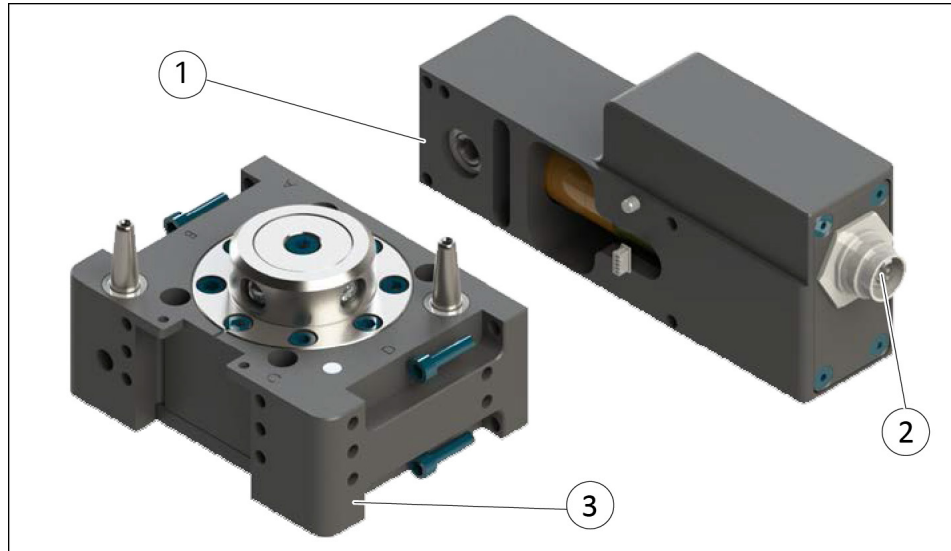

Servo Motor Modules

1	24 VDC Series Servo Motor with an integrated Controller mounted on Flat A
2	12-Pin Motor Control and Power Connector
3	EWK-018 Change Adapter

1.4 Optional Modules

There are three flats available for mounting of the optional modules for support of various utility pass-through, such as signal and power. The EWS supports K series and optional modules with J16 mounting patterns.

For assistance in choosing the right modules for your particular application, visit our website to see what is available or contact an SCHUNK Sales Representative directly.

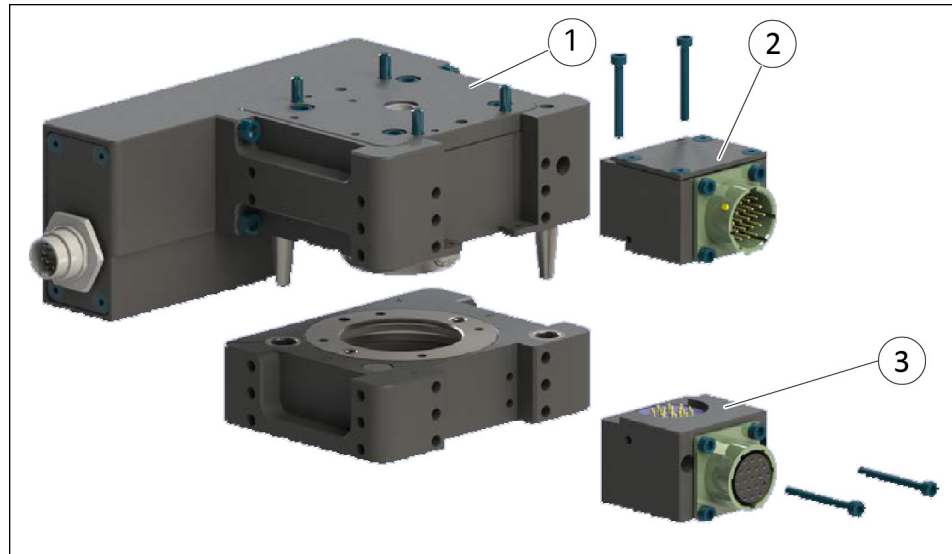

Optional Modules

1	EWK-018 Quick Change Master
2	Optional Module
3	Optional Module
4	EWA-018 Quick Change Adapter

2 Installation

The Quick Change Master is attached to the robot arm and may require an interface plate to match mounting patterns or create space to accommodate hollow wrist utilities. The Quick Change Adapter is attached to the tooling and may require an interface plate to match mounting patterns.



WARNING

Do not use lock washer under the head of the mounting fasteners or allow the mounting fasteners to protrude above the mating surfaces of the EWK and EWA. Allowing fasteners to protrude above the mating surface will create a gap between the EWK and EWA and not allow the locking mechanism to fully engage, this can cause damage to equipment or personal injury. Make sure the mounting fasteners are flush or below the mating surfaces of the EWK and EWA.

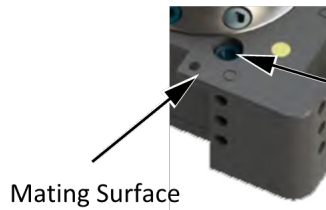

Head of Mounting Fastener Must Be Flush or Below Mating Surface. (Do Not Use Lock Washer under Head of Mounting Fastener).

⚠ WARNING

Do not perform maintenance or repair on Electric Tool Changer or modules unless the Tool is safely supported or docked in the tool stand, all energized circuits (e.g. electrical, air, water, etc.) are turned off, pressurized connections purged and power discharged from circuits in accordance with the customer's safety practices and policies. Injury or equipment damage can occur with Tool not docked and energized circuits on. Dock the Tool safely in the tool stand, turn off and discharge all energized circuits, purge all pressurized connections, verify all energized circuits are de-energized before performing maintenance or repair on Electric Tool Changer or modules.

⚠ WARNING

Mounting fasteners must have a thread locker such as Loctite 242 or equivalent applied to the threads unless they have a pre-applied thread locker. Fasteners may come loose resulting in injury to personnel or damage to equipment. Use fasteners with pre-applied thread locker or apply thread locker to all mounting fasteners.

⚠ CAUTION

Do not use fasteners that exceed the thread depth in the Electric Tool Changer. Secure the Electric Tool Changer with the proper length fasteners. This is true for both robot and tool interfaces.

2.1 Quick Change Master Interface

The Quick Change Master EWK is attached to the robot arm. The EWK is designed with mounting features such as a boss and/or bolt and dowel holes. These features are used to accurately position and secure the EWK to the robot.

A Robot Interface Plate (RIP) is utilized to adapt the EWK to a specific robot flange that is not compatible with the EWK mounting features. Custom RIPs are available upon request.

If the customer chooses to design and build a robot interface plate, the following should be considered:

	<p>⚠ CAUTION</p>
<p>Do not use more than two alignment features when securing a EWK to a robot interface plate. Using more than two alignment features can cause damage to equipment. Use either two dowel pins or a single dowel pin along with a boss/recess feature to align the EWK with the robot interface plate.</p>	

	<p>⚠ CAUTION</p>
<p>Do not use dowel pins that are too long that will not allow the interface plate and EWK body to mate flush with each other. Using dowel pins that are too long will cause a gap between the interface plate and the EWK body causing damage to the equipment. Use the proper size dowel pins that will not extend further than allowed by the EWK body.</p>	

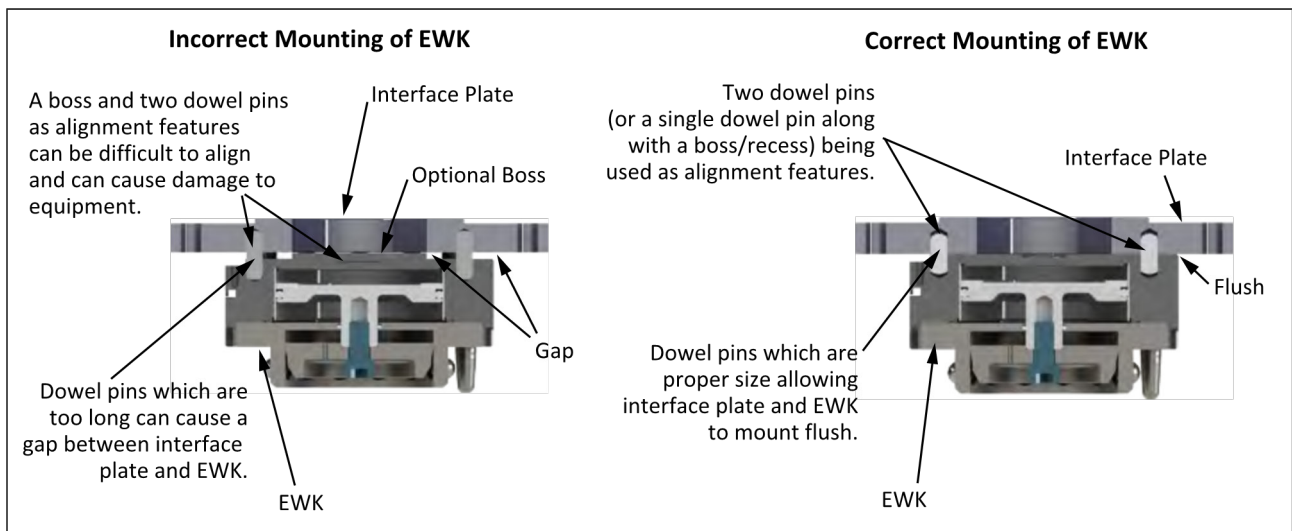

- The interface plate should be designed to include bolt holes for mounting, dowel pins and a boss for accurate positioning on the robot and EWK. The dowel and boss features are important to prevent rotation. Refer to the robot manual for robot mounting features.
- The thickness of the interface plate must be great enough to provide the necessary thread engagement for the mounting bolts.
- Dowel pins must not extend out from the surface of the RIP farther than the depth of the dowel holes in the EWK.
- If a boss is used on the EWK, a recess of proper depth and diameter must be machined into the RIP to correspond with the boss on the EWK.

- Mounting bolts should not be too long, such that a gap is formed at the interface.
- The interface plate must be properly designed to provide rigid mounting to the EWK boss area and to maintain a gap between the interface plate and the body outside of the boss.
- The plate design should take into account clearances required for Electric Tool Changer module attachments and accessories.

2.2 Quick Change Master Installation

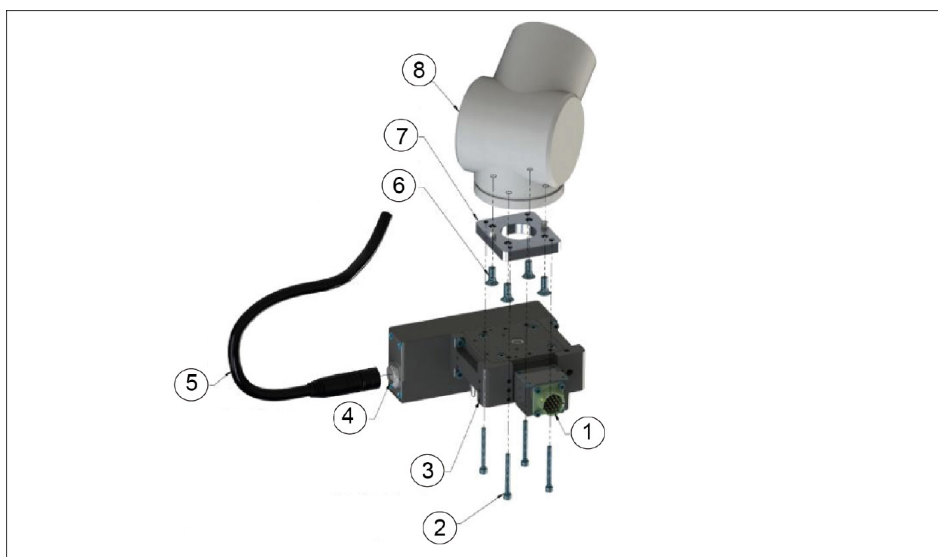

Typical Quick Change Master Installation

1	Electrical Connection
2	4 M4 Socket Head Cap Screws
3	EWK-018 Assembly
4	12-Pin Connector
5	EWS-018 with Controller to Customer Interface Cable
6	Customer Supplied Mounting Fasteners
7	SCHUNK or Customer Supplied Interface Plate (if required)
8	Robot

- ✓ Tools required: 4 mm Allen wrench (hex key), torque wrench
 - ✓ Supplies required: clean rag
- 1 Make sure mounting surface of the EWK and robot arm or RIP are clean and free of debris.
 - 2 If an interface plate is required attach the plate to the robot using appropriate mounting fasteners and torque values.

- 3 Attach the Quick Change Master EWK to the Interface plate using the four M4 socket head cap screws provided. Tighten to 1.4 to 1.7 Nm.
- 4 Connect and route the cable and secure per customer cable routing requirements.
- 5 Connect controller to customer interface cable to the 12-Pin connector on the motor controller or EWS servo motor module and connect cable to customer interface as prescribed in Section "Electrical Connections" ([↩ 2.7, Page 18](#)).
- 6 Connect any electrical connection to optional modules.
- 7 If installation is complete, the EWK may be put into normal operations.

2.3 Quick Change Master Removal

- ✓ Tools required: 4 mm Allen wrench (hex key)
- 1 Dock the Tool safely in the tool stand and uncouple the Electric Tool Changer to allow clear access to the EWK.
 - 2 Turn off all energized circuits (e.g. electrical, air, water, etc.).
 - 3 If needed, disconnect all utilities (e.g. electrical, air, water, etc.). Note: support the EWK while removing the fasteners.
 - 4 Remove four M4 socket head cap screws connecting the EWK to the robot arm or RIP.



2.4 Quick Change Adapter Interface

The Quick Change Adapter EWA is attached to the customer's tooling. It may be necessary for an interface plate to be utilized to adapt the EWA to customer's tooling. The EWA is designed with alignment features (dowel holes and a recess) to accurately position and bolt holes to secure the EWA to customer's tooling. Custom tool interface plates can be supplied by SCHUNK to meet customer's requirements

If the customer chooses to design and build a tool interface plate, the following should be considered:

	<p>⚠ CAUTION</p>
	<p>Do not use more than two alignment features when securing an EWA to an interface plate. Using more than two alignment features can cause damage to equipment. Use either two dowel pins or a single dowel pin along with a boss/recess feature to align the EWA with the interface plate.</p>

	<p>⚠ CAUTION</p>
	<p>Do not use dowel pins that are too long that will not allow the interface plate and EWA body to mate flush with each other. Using dowel pins that are too long will cause a gap between the interface plate and the EWA body causing damage to the equipment. Use the proper size dowel pins that will not extend further than allowed by the EWA body.</p>

Incorrect Mounting of EWA	Correct Mounting of EWA
<p>Boss and two dowel pins as alignment features can be difficult to align and can cause damage to equipment.</p>  <p>Dowel pins which are too long can cause a gap between interface plate and EWA.</p> <p>Interface Plate</p>	<p>Two dowel pins (or a single dowel pin along with a boss/recess) being used as alignment features.</p>  <p>Dowel pins which are proper size allowing interface plate and EWA to mount flush.</p> <p>Interface Plate</p>

- 1 The interface plate should be designed to include bolt holes for mounting and either two dowel pins or a dowel pin and a boss for accurate positioning on the customer tooling and EWA. The dowel and boss features are important to prevent rotation.
- 2 Dowel pins must not extend out from the surface of the interface plate farther than the depth of the dowel holes in the EWA.
- 3 The thickness of the interface plate must be great enough to provide the necessary thread engagement for the mounting bolts. Fasteners should be chosen to meet minimum recommended engagement lengths while not exceeding the maximum available thread depth. Use of bolts that are too long can cause damage to the tool side changer.
- 4 The plate design should take into account clearances required for Electric Tool Changer module attachments and accessories.
- 5 If a boss is to be used on the interface plate, a boss of proper height and diameter must be machined into the interface plate to correspond with the recess in the Tool plate.
- 6 The tool interface plate should be designed with a hole in its center to allow for manually returning the locking mechanism to the unlocked position under adverse conditions (i.e. unintended loss of power and/or air pressure). The center access hole should be kept small [minimum recommended hole diameter: 1" (25.4 mm)] to prevent debris from contaminating the locking mechanism while operating in dirty environments. Even greater protection will result if the standard race cover with removable access plug is used. [Note: Through hole diameter in plate: 0.563" (14.3 mm). Grommet outside diameter: 0.88" (22.5 mm)].

2.5 Quick Change Adapter Installation

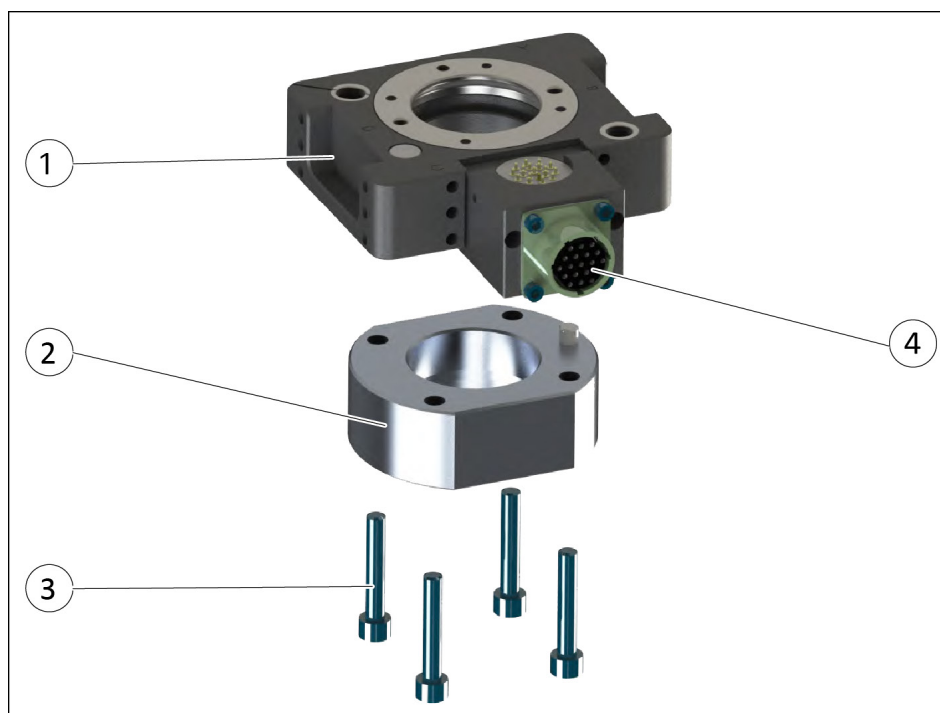

Typical Tool Installation

1	Quick Change Adapter EWA
2	Tool or Interface Plate Supplied by Customer
3	Mounting fasteners Supplied by Customer
4	Electrical Connection

- ✓ Tools required: 4 mm Allen wrench (hex key), torque wrench
- 1 Make sure the mounting surface of the Tool plate and tool interface plate is clean and free of debris.
 - 2 Attach Tool or Interface plate to the Quick Change Adapter EWA using the customer supplied M6 mounting fasteners. Tighten to appropriate torque.
 - 3 If required attach the Tool Hanger, refer to the tool stand installation and operation manual.
 - 4 After Tool base is secured, connect any electrical connection to optional modules.
 - 5 If installation is complete, the Tool plate may be put into normal operations.

2.6 Quick Change Adapter Removal

- ✓ Tools required: 4 mm Allen wrench (hex key)
- 1 Dock the Tool safely in the tool stand and uncouple the Electric Tool Changer to allow clear access to the Quick Change Adapter.
- 2 Turn off all energized circuits (e.g. electrical, air, water, etc.).
- 3 If needed, disconnect all utilities (e.g. electrical, air, water, etc.).
- 4 Remove the fasteners connecting the Quick Change Adapter to the tooling or tool interface plate.

2.7 Electrical Connections

The cable connection from the motor controller to the customer connection is provided through pigtailed connections, refer to the following table for specific wire color and signal information. The US1 power (100mA at 24 VDC) provides power to the Locked, Unlocked and RTL sensors.

	⚠ CAUTION
	<p>Poor cable routing can also result in wires and cables being pinched in the joint between the Tool Changer halves.</p> <p>Failure to observe this point may result in premature failure of the industrial electrical connectors.</p> <ul style="list-style-type: none"> • Properly route and secure all cables, particularly on the EWK side.

Customer Cable Pigtail Connections

Wire Color	Signal	Signal Description
Violet	US1	+24V Power for Locked, Unlocked and RTL sensors
Yellow	US1 GND	Ground
Red	US2	+24V Power for the motor and motor controller
Green	US2 GND	Ground
Black	Latch	+24V output supplied to the SCHUNK EWK module to couple the Tool Changer.

Wire Color	Signal	Signal Description
Orange	Unlatch	+24V output supplied to the SCHUNK EWK module to uncouple the Tool Changer.
White	Locked	+24V proximity sensor input indicating that the coupling mechanism is in the Locked position.
Tan	Unlocked	+24V proximity sensor input indicating that the coupling mechanism is in the Unlocked position.
Blue	RTL	+24V proximity sensor input that senses when the SCHUNK Tool is in close proximity
Brown	No Connect	
Gray	No Connect	
Pink	No Connect	

The US2 power (200mA standby, 3A max.) at 24 VDC provides power to the motor controller and motor. The US1, US2, Latch and Unlatch connection voltage supply should be 20-30 VDC.

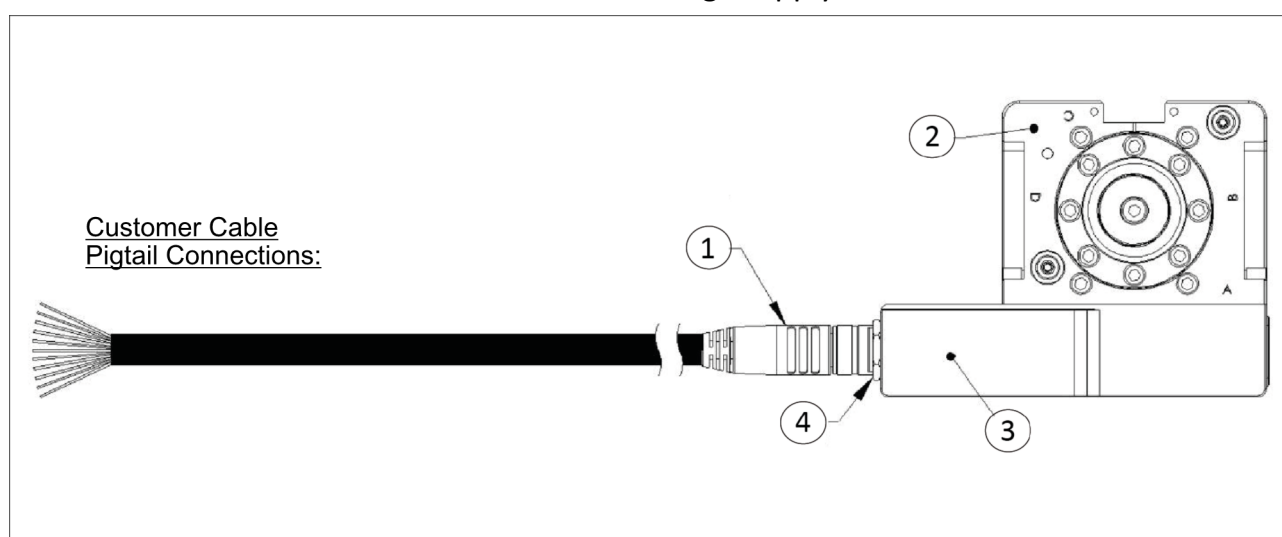

Electrical Connections

1	Customer Cable Length to be determined Pigtail Connection on Customer End
2	EWK-018
3	Servo Motor Module with Integrated Controller
4	Customer Cable Connector 12 Pin Female Receptacle

2.8 Lock Actuation Speed DIP Switch Settings

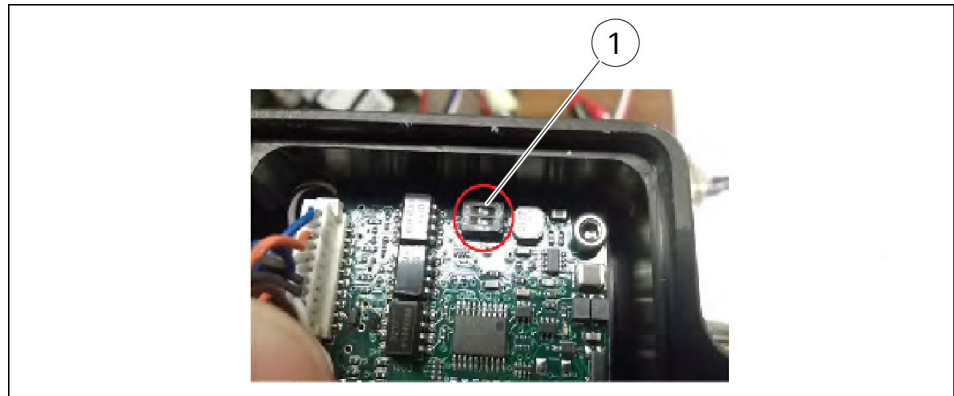

Lock Speed Algorithm selection is based on DIP switch (1) settings. Default DIP setting is: SW1 channel 1 off, channel 2 off. Unlock speed is always 1 second.

DIP Switch Settings

Lock Algorithm	DIP SW1	DIP SW2	Speed (sec.)
Regular Speed	off	off	1
Medium 1 speed	off	on	30
Medium 2 speed	on	off	200
Slow speed	on	on	360

3 Operation

The EWK locking and drive mechanism is mechanically-driven to couple and uncouple with the bearing race on the EWA. The EWK utilizes drive torque from a motor module to provide lock and unlock forces to the locking mechanism.

The following procedures provide general guidelines for operational sequence of the EWS. The motor controller electronics and software provide operational behavior that is intended to ensure proper operation and prevent damage to the unit. Refer to Section "Motor Controller Algorithms" for details on specific motor controllers.

NOTE

All EWS are initially lubricated using MobilGrease® XHP222 Special grease. The end user must apply additional lubricant to the locking mechanism components and alignment pins prior to start of service (See [☞ 4.2, Page 30](#)). Tubes of lubricant for this purpose are shipped with every EWS.

MobilGrease® XHP222 Special is a NLGI #2 lithium complex grease with molybdenum disulfide.

The robot should be programmed to minimize misalignment during coupling and uncoupling. Additionally, the tool stand should be durable and not allow deflection, under uncoupled Tool weight that will take alignment of the Electric Tool Changer outside of accepted offsets. See following Figure and following Table for recommended maximum allowable offsets prior to coupling. In some cases, greater offsets than shown in the following table can be accommodated by the EWK and EWA but will increase wear.

Lock up should occur with the Quick Change Master in the No-Touch™ locking zone (see the following table) but not touching the Quick Change Adapter. As locking occurs, the Quick Change Master should draw the Quick Change Adapter into the locked position.

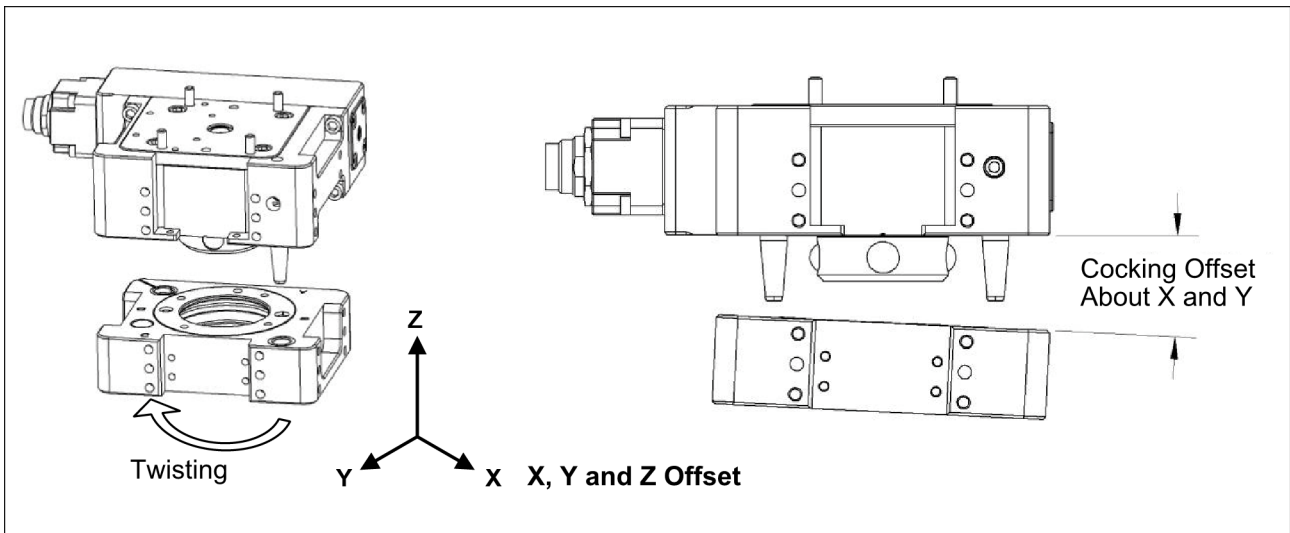

Offset Definitions

Maximum Recommended Offsets Prior to Coupling

Model	Z Offset (Max) ¹ [mm]	X and Y Offset (Max) ² [mm]	Cocking Offset (Max) [degrees]	Twisting Offset (Max) [degrees]
EWS-018	1	±1	±0.7	±1

Notes:

- 1) Maximum values shown. Decreasing actual values will minimize wear during coupling/uncoupling.
- 2) Actual allowable values may be higher in some cases but higher offsets will increase wear during coupling.

3.1 Conditions for Coupling

	⚠ CAUTION
	<p>The locking mechanism must be in the unlock position when attempting to couple the Tool Changer.</p> <p>Failure to adhere to this condition may result in damage to the unit and/or the robot.</p>

NOTE

When the unit powers up, the EWS will remain in place until a latch or unlatch signal is received. A +24V signal on the Latch wire will make the EWS lock. A +24V signal on the Unlatch wire will make the EWS Unlock. Once a signal is received, the EWS will move to that location until the cycle is complete. The first latching and unlatching cycles after power up may be slow due to the unit needing to home itself.

- 1 Position the EWK above the EWA and move the EWK into locking position. The mating surfaces of the EWK and EWA should be parallel and not touching. Make sure that the tapered alignment pins from the EWK enter the alignment holes on the EWA. The alignment pins should be relatively concentric with the alignment holes such that they do not rub against the edge.
- 2 The locking mechanism allows the EWK to "pull up" the EWA with gaps between the two sides. It is recommended that the mating faces of the EWK and EWA not be touching, but be within 1 mm of each other when coupling to minimize stress and wear on the locking mechanism.
- 3 RTL (Ready-To-Lock) sensing is built into the EWS, providing the ability to sense EWA proximity to the EWK prior to locking. The mating faces of the EWK and EWA must be positioned within approximately 0.04" (1 mm) of each other for the sensors to detect EWA presence. RTL signals are not required to couple the EWS, but are recommended as a further confirmation of coupling prior to removing the EWA from the Tool Stand.
- 4 If the EWS is in the proper position or the same signal is raised a consecutive number of times, the unit will not respond to the redundant signals. The RTL signal is to notify the user that the tool is in position to lock the EWS, but the EWA should be completely mated to the EWK prior to raising the Latch signal.



⚠ CAUTION

No-Touch™ locking technology allows the unit to couple with a separation distance between the EWK and EWA. Direct contact of the EWK and Tool mating surfaces is not suggested or required just prior to coupling.

Contact may result in damage to the unit and/or the robot.

- 5 Verify that the RTL signals are read as “on” (true).
- 6 Turn the Lock command on. Signal is sent to the motor module to couple the Tool Changer.
- 7 A sufficient delay must be programmed between the Lock command being activated and reading the state of the Locked/Unlocked signals, so that the locking process is completed before checking the locked state.
- 8 Read the Locked and Unlocked signals.
- 9 The Locked signal should read “on” (true) and the Unlocked signal should read “off” (false).
- 10 If the locking mechanism has been actuated and both the Locked and Unlocked signals are read as “off” (false), then a “missed tool” condition has occurred (for example, the Tool is not in the stand or is not positioned properly). In this case an error should be generated and the robot program halted. The situation requires manual inspection to determine the cause of the problem.
- 11 The locking mechanism must be in the Unlocked state before another attempt is made to couple or damage could occur to the robot and/or the Tool Changer.

3.2 Fail-Safe Operation

In the event of power loss to the locking mechanism the Tool Changer will not uncouple. A slight separation between the Quick Change Master EWK and Quick Change Adapter EWA might occur just after power loss, but at this point the worm gear teeth will not back drive without power being applied to the unlock command. This feature provides the Tool Changer with a fail-safe mechanism. The fail-safe design prevents the EWA from being released in the event of power loss to the motor, thereby increasing safety and reliability. Positional accuracy may not be maintained during power loss but will be regained once power is re-established to the motor module.





CAUTION

Do not use the Tool Changer in the fail-safe condition for extended periods of time. Do not transport the Tool Changer in the fail-safe condition.

Possible damage to the locking mechanism could occur.



3.3 Conditions for Uncoupling

- 1 The Tool Changer should be positioned in the Tool Stand in the same location as when coupling took place.

	 CAUTION
	<p>This Tool Changer may be equipped with a Tool Stand Interlock (TSI) feature that physically breaks the Unlock circuit. Use of the TSI will prevent any unwanted Unlock software commands from being recognized until the circuit is made.</p>

- 2 Turn the Lock command off.
- 3 Issue the Unlock command. Power is supplied to the locking mechanism to uncouple the Tool Changer.
- 4 A sufficient delay must be programmed between Unlock command being activated and reading the state of the Locked/Unlocked signals, so that the locking process is completed before checking the Locked state.
- 5 Read the Locked and Unlocked signals.
- 6 The Unlocked signal should read “on” (true) and the Locked signal should read “off” (false). Any other condition indicates a problem and the robot program should be halted.
- 7 Once the Lock and Unlock signals are verified to be in the proper state the EWK may be moved away from the EWA in the axial direction.
- 8 The robot and EWK can now proceed to another Tool for coupling and subsequent operations.

3.4 Tool Storage Considerations

	 CAUTION
	<p>Tool stand design is critical to proper operation of the Tool Changer. Improperly designed tool stands can cause misalignments that will cause jamming and/ or excessive wear of Tool Changer components.</p>

The tools may be stored in a tool stand when not being used by the robot. SCHUNK provides compatible tool stands designed for durability, longevity, and maximum adaptability to fit most customers’ applications. The SCHUNK TSS (Tool Stand Small) system is compatible with SCHUNK Tool Changer. The TSS systems can be

equipped with horizontal modules, clamp modules, and different types of tool sensing. Two mounting styles are available: a pin and bushing style and a pin and rack style. Contact SCHUNK for recommendations and assistance.

If the customer is supplying the tool stand, it should be designed to provide a fixed, repeatable, level, and stable positions for tool pick up and drop off. The tool stand must support the weight of the Tool Changer, Tool Interface Plate, optional modules, cables, hoses, and customer tooling without allowing deflection in excess of the offsets specified in Section "Operation".

Ideally, the Tool should be hanging vertically in the tool stand so that gravity assists to uncouple the EWA from EWK during unlocking. It is possible to design tool stands that hold tools in the horizontal position but care must be taken that the necessary compliance is provided during coupling and uncoupling. In general, "horizontal position" tool stands cause more wear on the locking mechanism and locating features of the Tool and tool stand.

A variety of methods may be used to position the Tool in the tool stand. A common method is to use tapered alignment pins and bushings. Robot programming and positional repeatability are vital in tool pick up and drop off, refer to Section "Operation".

It is highly recommended that the customer provide a sensor that detects the presence of a properly seated Tool in the tool stand. The sensor may be used prior to coupling to ensure there is a Tool properly seated in the stand. Sensors may also be used as the robot starts to move away after uncoupling. This provides a safety measure in the event that a Tool should become jammed in the stand or if the Tool should fail to release properly from the robot.

Proximity sensors should be positioned so that the sensing face is vertical to prevent metal shavings, weld spatter, or other debris from falling on the sensor and creating false readings.

Tool stands may also need to incorporate means for covering Tools and modules to protect them in dirty environments, such as grinding or welding. Alternatively, positioning tool stands in areas shielded from weld spatter, fluids, adhesives, or other debris would eliminate the need for tool covers.

4 Maintenance



DANGER

This module has a voltage of 50 V or greater, NO contact should be attempted before removing power. This especially includes separation or insertion of the mating connectors or any contact with the Tool Changer or its components. Arcing and damage will occur if this is not observed.

- Remove power before attaching, disconnecting any cables or attempting any maintenance of Tool Changer.



WARNING

Do not perform maintenance or repair on Tool Changer or modules unless the Tool is safely supported or docked in the tool stand, all energized circuits (e.g. electrical, air, water, etc.) are turned off, pressurized connections purged and power discharged from circuits in accordance with the customer's safety practices and policies.

Injury or equipment damage can occur with Tool not docked and energized circuits on.

- Dock the Tool safely in the tool stand, turn off and discharge all energized circuits, purge all pressurized connections, verify all energized circuits are de-energized before performing maintenance or repair on Tool Changer or modules.

NOTE

The cleanliness of the work environment strongly influences the trouble-free operation of the changer. The dirtier the environment, the greater the need is for protection against debris. Protection of the entire EOAT, the EWK, the EWA, and all of the modules may be necessary. Protective measures include the following:

- Placement of Tools Stands away from debris generators,
- Covers incorporated into the Tool Stands.
- Guards, deflectors, air curtains, and similar devices built into the EOAT and the Tool Stand.

4.1 Preventive Maintenance

The Electric Tool Changer and optional modules are designed to provide a long life with regular maintenance. A visual inspection and preventive maintenance schedule is provided in the table below depending upon the application. Refer to module sections for detailed preventive maintenance steps for all utility modules.

Preventative Maintenance Checklist		
Application(s)	Tool Change Frequency	Inspection Schedule
General Usage, Material Handling, Docking Station	More than 1 per minute	Weekly
	Less than 1 per minute	Monthly
Welding/Servo/Deburring, Foundry Operations (Dirty Environments)	All	Weekly

Mounting Fasteners

- Inspect mounting fasteners, verify they are tight and have the proper torque.

Ball Bearings/Alignment Pins/Bushings/Bearing Race

- Inspect for wear and proper lubrication. MobilGrease XHP222 Special is a NLGI #2 lithium complex grease with molybdenum disulfide additive is suggested for locking mechanism and alignment pin lubrication. Over time, lubricants can become contaminated with debris. Therefore, it is recommended to thoroughly clean the existing grease and replace with new as needed. Refer to [\(☞ 4.2, Page 30\)](#).
- Inspect for excessive alignment pin/bushing wear, may be an indication of poor robot position during pickup/drop off. Adjust robot position as needed. Check tool stand for wear and alignment problems. To replace worn alignment pins. Refer to [\(☞ 5.3.2, Page 38\)](#).
- Inspect for wear on the ball bearings/bearing race, may be an indication of excessive loading.

Sensors and Cables

- Inspect sensor cable connectors for tightness, if loose tighten connections.

Electrical Contacts/Pin Block (Modules)

- Inspect for damage, debris, and stuck/burnt pins. Clean pin blocks as required. Refer to [\(🔗 4.3, Page 32\)](#).

Seals (Modules)

- Inspect for wear, abrasion, and cuts. Refer to [\(🔗 5.3.1, Page 37\)](#)

4.2 Cleaning and Lubrication of the Locking Mechanism and Alignment Pins

Supplies required: clean rag, cotton swabs, NLGI #2 lithium complex grease

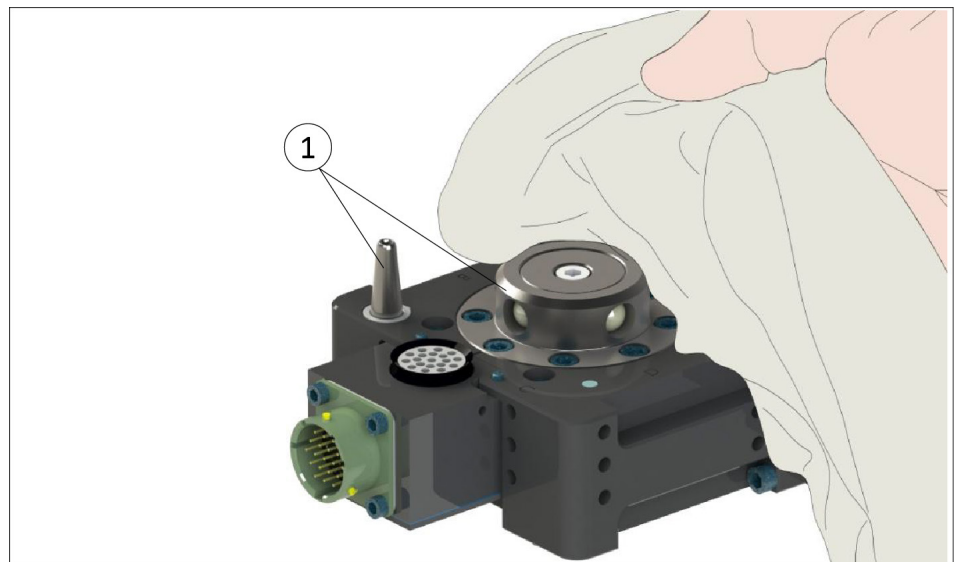

Clean Outer Surface of Locking Mechanism

- 1 Dock the Tool safely in the tool stand and uncouple the Tool Changer to allow clear access to the EWK and EWA. Leave the locking mechanism in the unlocked.
- 2 Turn off and de-energize all energized circuits (e.g. electrical, air, water, etc.).
- 3 The locking mechanism must be in the unlock state before cleaning.
- 4 Use a clean rag to thoroughly remove the existing lubricant and debris from the ball bearings, the male coupling, the cam, and the alignment pins (1).

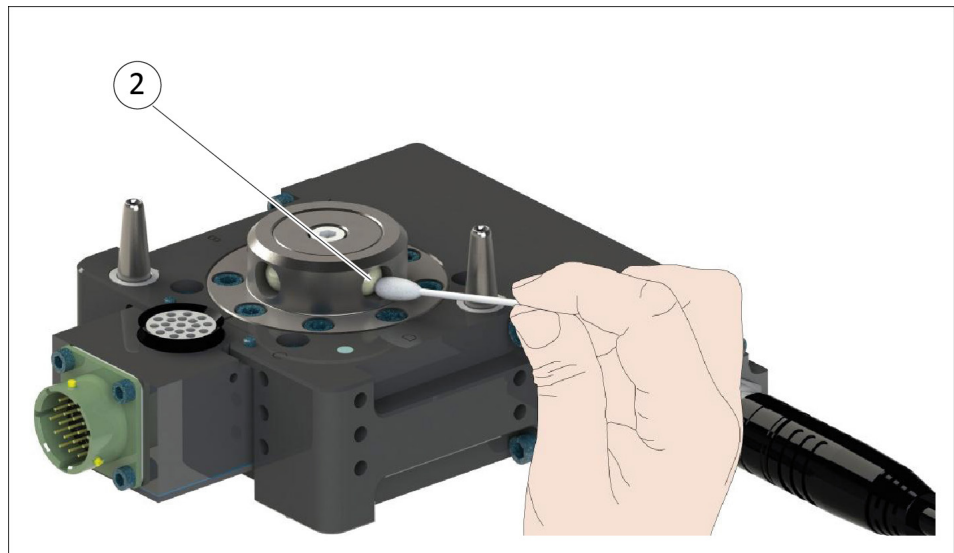

Cleaning Ball Bearings and Outer Surfaces of Male Coupling

- 5 Use a clean cotton swab to thoroughly remove the existing lubricant and debris from the balls, rotate the balls to clean in and around the balls (2).
- 6 Check each ball to make sure it moves freely in the male coupling. Additional cleaning may be necessary to free up any balls that are stuck in place.

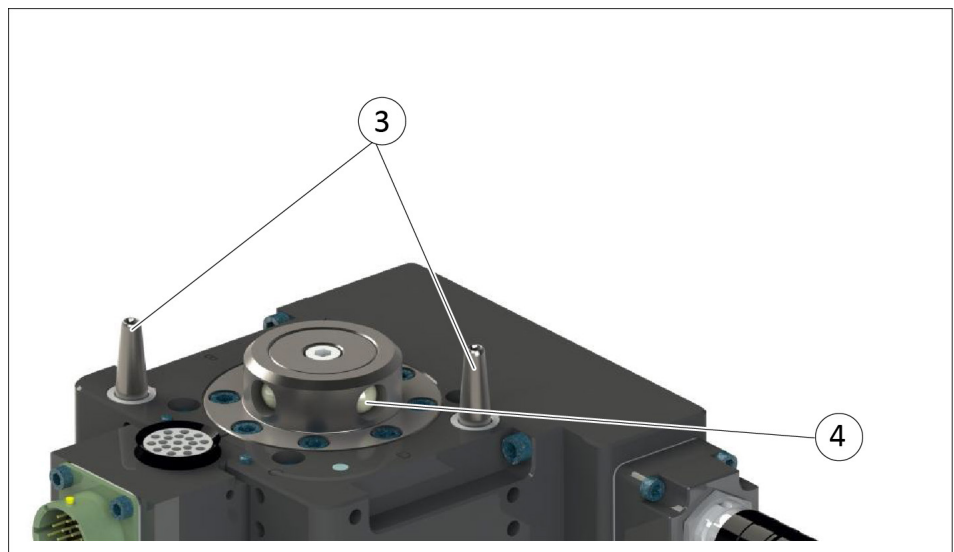

Cleaning Ball Bearings of Locking Mechanism

- 7 Apply a liberal coating of lubricant to the balls (4), the male coupling (inside and out), and the alignment pins (3).

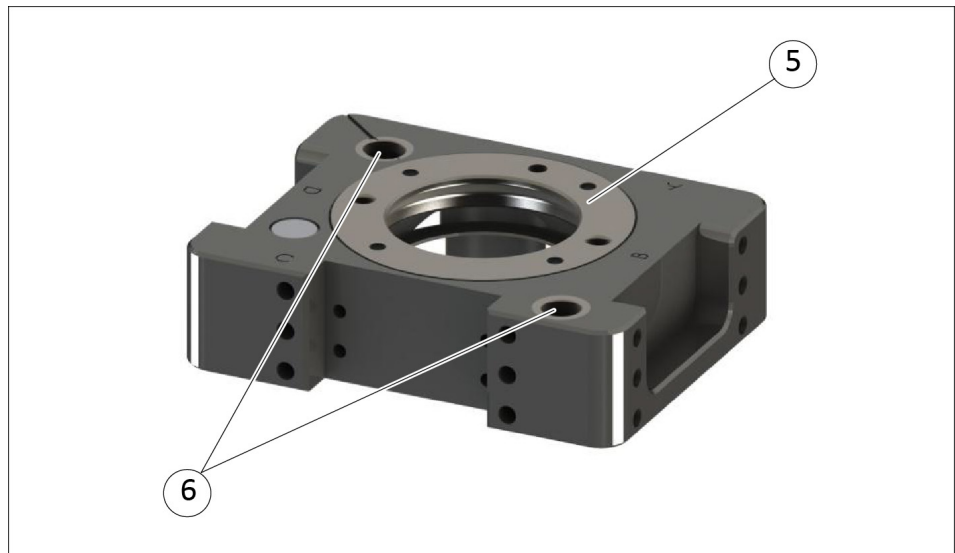

Clean EWA Surface of Locking Mechanism

- 8 Use a clean rag to thoroughly remove any lubricant and debris from the bearing race (5) and the bushings (6) from the EWA.
- 9 No application of lubrication is necessary on the EWA components.
- 10 After repair is complete, return all circuits to normal operation (e.g. electrical, air, water, etc.).

4.3 Pin Block Inspection and Cleaning

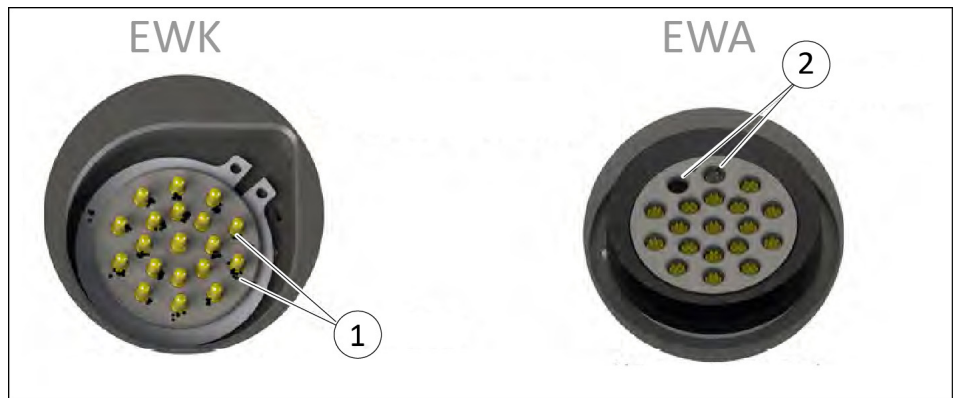

Pin Blocks

1	Weld Debris
2	Blackened Pins

✓ Tools required: Nylon Brush

- 1 Dock the Tool side of the Tool Changer safely and uncouple the Tool Changer to allow clear access to the EWK and EWA.
- 2 Turn off and de-energize all energized circuits (e.g. electrical, air, water, etc.).

- 3 Inspect the EWK and EWA pin blocks for any debris or darkened pins.
- 4 If debris or darkened pins exist, remove debris using a vacuum, and clean using a nylon brush.

NOTE

Do not use an abrasive media, cleaners, or solvents to clean the contact pins.

- Using abrasive media, cleaners, or solvents will cause erosion to the contact surface or pins to stick.
- Clean contact surfaces with a vacuum and non-abrasive media such as a nylon brush.

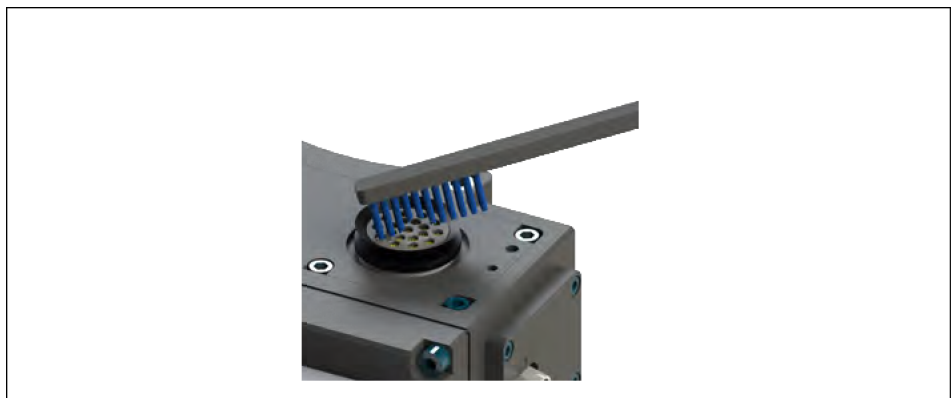

Clean Pin Blocks

- 5 Inspect the EWK and EWA pin blocks for stuck pins (1) or severe pin block damage (2).

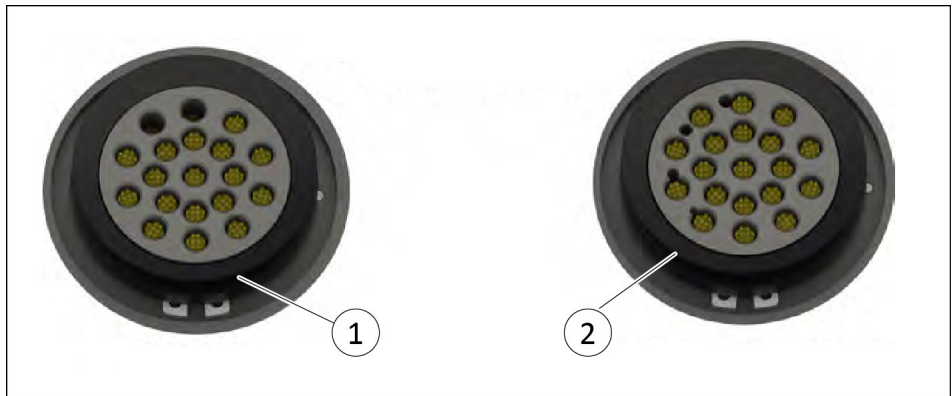

Stuck Pin and Pin Block Damage

- 6 If stuck pins or severe pin block damage exists, contact SCHUNK for possible pin replacement procedures or module replacement.
- 7 If repairs are complete, return circuits to normal operation.

5 Troubleshooting and Service Procedures

The following section provides troubleshooting and service information to help diagnose conditions and repair the Electric Tool Changer or control module.

	⚠ WARNING
	<p>Do not perform maintenance or repair on Electric Tool Changer or modules unless the Tool is safely supported or docked in the tool stand, all energized circuits (e.g. electrical, air, water, etc.) are turned off, pressurized connections purged and power discharged from circuits in accordance with the customer’s safety practices and policies. Injury or equipment damage can occur with Tool not docked and energized circuits on. Dock the Tool safely in the tool stand, turn off and discharge all energized circuits, purge all pressurized connections, verify all energized circuits are de-energized before performing maintenance or repair on Electric Tool Changer or modules.</p>

5.1 Troubleshooting Procedures

The troubleshooting table is provided to assist in diagnosing issues that may cause the Tool Changer not to function properly.

5.1.1 Unit will not lock or unlock?

Cause	Corrective action
Debris caught between the EWK and EWA.	Debris caught between the EWK and EWA. Clean debris from between EWK and EWA. Verify mounting fasteners are secure and do not protrude above the mating surfaces.
The ball bearings and/or cam are not moving freely in the male coupling.	Clean and lubricate as needed to restore smooth operation (see (👉 4.2, Page 30)).
The Motor Controller is not operating correctly.	Check cabling to and from motor controller, replace if damaged.

Cause	Corrective action
The EWK and EWA are not within the specified No-Touch zone when attempting to lock.	<p>Check that the tool is properly seated in the tool stand, (☞ 3.4, Page 26).</p> <p>Re-teach the robot to bring the EWK and EWA closer together prior to attempting to lock.</p>
Ready-To-Lock (RTL) sensors not activated indicating Tool is not positioned properly	<p>Check that the EWA is properly seated in the tool stand.</p> <p>Re-teach the robot to bring the EWK and EWA closer together prior to attempting to lock.</p> <p>Check all cables for damage and that they are connected properly to the signal control module. Replace damaged cables as necessary.</p> <p>Check that both RTL sensors are not damaged. Replace damaged RTL sensors as necessary, contact SCHUNK for possible pin replacement procedures or module replacement.</p>
The motor is not operating correctly.	Check motor, replace if damaged. Refer to (☞ 5.3.3, Page 39).

5.1.2 Loss of Communication?

only for units equipped with Electrical/Servo/Control/Signal Modules

Cause	Corrective action
Debris in and around contact pins. Contact Pin worn or damaged.	Inspect V-ring seal for damage, replace damaged seal. Refer to Section (☞ 5.3.1, Page 37)
Cable connections loose or cables damaged.	Check that cable connections are secure and cables are not damaged.

5.2 Manual Lock and Unlock



⚠ CAUTION

- Never couple or uncouple the unit without first disconnecting and discharging the power that passes through the contacts. This is especially true if high voltage circuits are involved. Arcing and contact damage will occur if this is not observed.
- Always disconnect and discharge electrical power from both upstream and downstream modules.



⚠ WARNING

An unsupported tool could cause damage to equipment or injury to personnel.

- Do not manually unlock the Tool Changer without supporting the tool.
- Support the tool before attempting to manually unlock the Tool Changer.

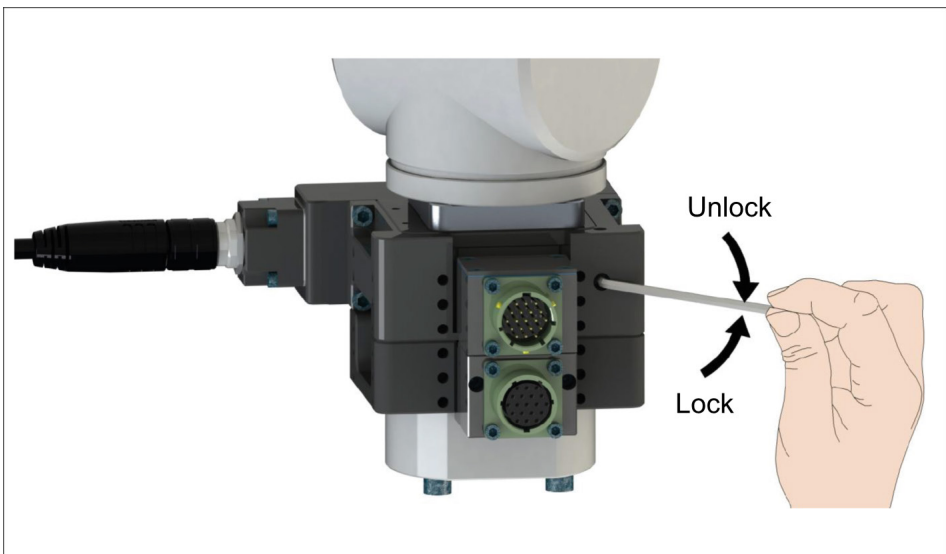

Manual Lock/Unlock

In certain cases it may be necessary to manually unlock the Tool Changer.

✓ Tools required: 3 mm Allen wrench (hex key)

1

Use a 3 mm allen wrench and access the unit's drive shaft from the side of the EWK. It takes approximately 8 turns to fully unlock the unit.

5.3 Service Procedures

The following service procedures provide instructions for component replacement.

5.3.1 V-ring Seal Replacement

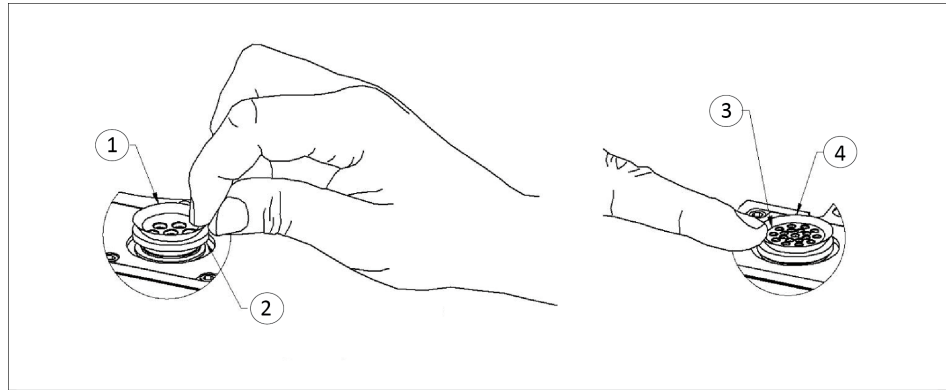

V-Ring seal Replacement

The seals (1 and 4) protect the electrical connection between the EWK and EWA. If the seals (1 and 4) become worn or damaged, they need to be replaced.

- 1 Dock the tool safely in the tool stand and uncouple the Electric Tool Changer to allow clear access to the EWK and EWA. Leave the locking mechanism unlocked.
- 2 Turn off and de-energize all energized circuits (e.g. electrical, air, water, etc.)
- 3 To remove the existing seal, pinch edge of seal with fingers and gently pull the seal away from the pin block (2) on the EWK.
- 4 Pull the seal off the pin block.
- 5 To install a new seal, stretch the new seal over the shoulder of the pin block (3).
- 6 Push the seal's hub down against the pin block using finger tip.
- 7 After repair is complete, return all circuits to normal operation.

5.3.2 Alignment Pin Replacement



Replace Alignment Pins

✓ Tools required: 4 mm Allen wrench (hex key), torque wrench

✓ Supplies required: NLGI #2 lithium complex grease

- 1 Dock the Tool safely in the tool stand and uncouple the Electric Tool Changer to allow clear access to the EWA.
- 2 Turn off and de-energize all energized circuits (e.g. electrical, air, water, etc.).
- 3 Unscrew the alignment pin (3) from the EWK (4) using a 2.5 mm Allen wrench (2).

NOTE

If for any reason the pin cannot be removed using the Allen wrench in the tip, it may be necessary to remove it by other means, such as locking pliers.

- 4 Apply Loctite 242 to threads of new alignment pin and install into EWK using a 2.5mm Allen wrench. Torque to 18 in-lbs (2.0 Nm).
- 5 Apply MobilGrease XHP222 Special grease to the alignment pin (see Section [4.2, Page 30](#)).
- 6 If repairs are complete, return circuits to normal operation.

5.3.3 Servo Motor Module Replacement

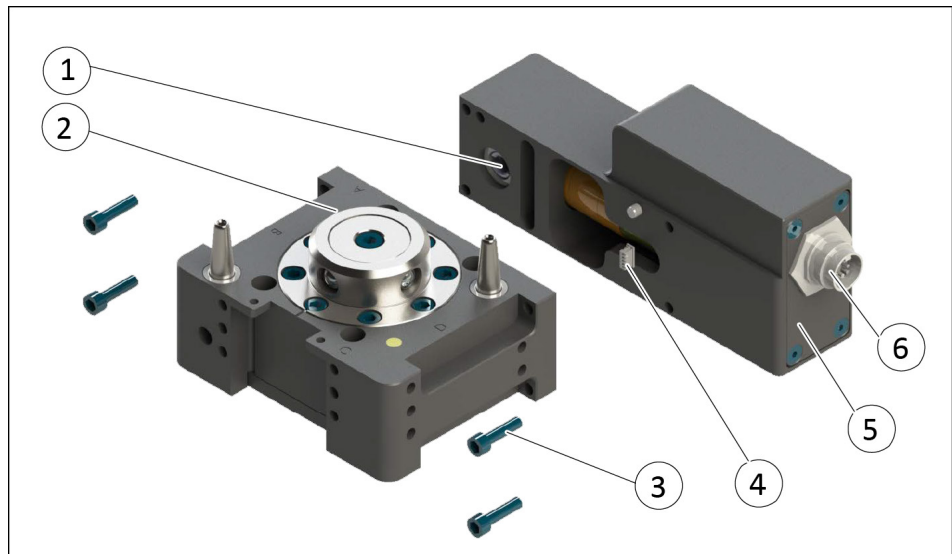

✓ Tools required: 4 mm Allen wrench (hex key), torque wrench

- 1 Dock the Tool safely in the tool stand and uncouple the Tool Changer to allow clear access to the EWK (2).
- 2 Turn off and de-energize all energized circuits (e.g. electrical, air, water, etc.).
- 3 Remove any optional module mounted on Flats B and D.
- 4 Disconnect the customer interface cable from the 12-pin connector (6).
- 5 Using a 4 mm Allen wrench, remove the four M4 socket head caps screws (3) mounting the servo motor module (5) to Flat A.
- 6 Remove the servo motor module and disconnect the motor electrical connector from the sensor connector.
- 7 Connect the motor electrical connector (4) of the new servo motor module (5) to the sensor connector of the EWK.

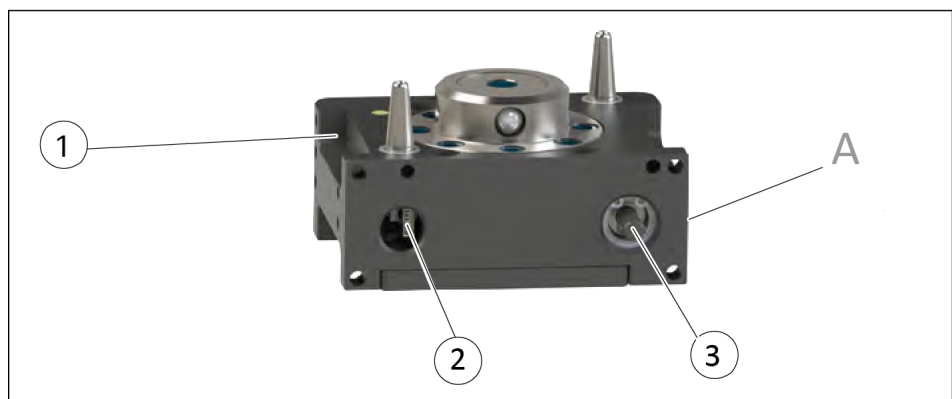

- 8 Install the new servo motor module onto the EWK, orient the drive shaft to allow the drive shaft to slide into the slots in the drive coupling (1).
- 9 If the fastener does not have pre-applied adhesive, apply Loctite 242 to threads of four M4 socket head caps screws and install into the servo motor module using a 4 mm Allen wrench. Torque to 25 in-lbs (2.82 Nm).
- 10 Connect the customer interface cable to the 12-pin connector.
- 11 After repair is complete, return all circuits to normal operation.

6 Serviceable Parts

6.1 Quick Change Master (EWK)

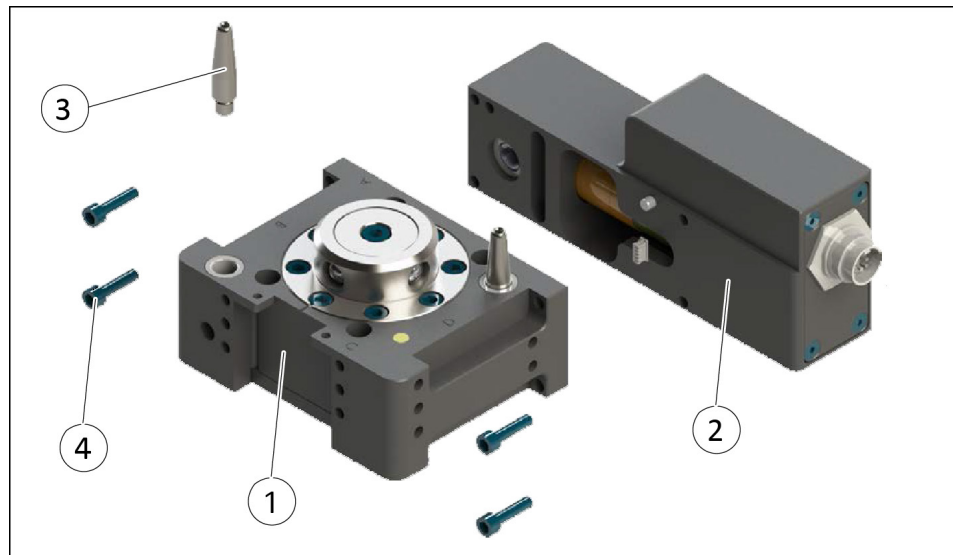

Item No.	Qty	Description
1	1	Complete Quick Change Master (EWK)
2	1	Motor Sub Assembly
3	2	Mono Alignment Pin
4	4	M4x16 SHCS, Class 12.9, Blue dyed Magni-565, ND Microspheres Epoxy, Yellow.

6.2 Quick Change Adapter (EWA)

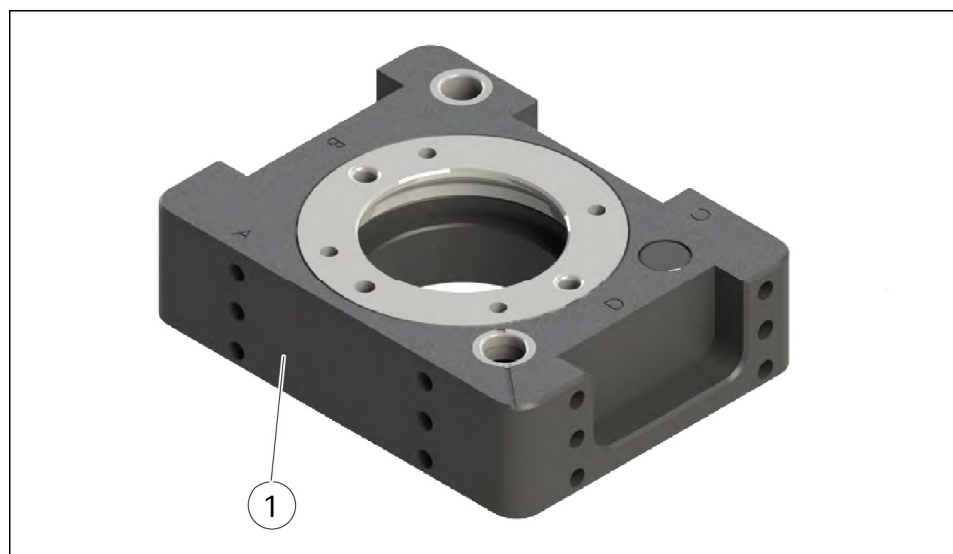

Item No.	Qty	Description
1	1	Complete Quick Change Adapter (EWA)

7 Specifications

Recommended Max Payload	18 kg	The mass attached to the Electric Tool Changer.
Operating Temperature Range	-12°C to 70°C	Optimal operating temperature range.
Operating Voltage	6 A @ 12-30 V DC	Locking mechanism supply operating voltage.
Positional Repeatability	0.0152 mm	Repeatability tested at rated load at one million cycles.
Weight	EWK 1,38 kg EWA 0,42 kg	
Max. Recommended distance between EWK and EWA	1 mm	No-Touch locking technology allows the EWK and EWA to lock with separation when coupling.

8 Translation of original declaration of incorporation

in terms of the Directive 2006/42/EG, Annex II, Part 1.B of the European Parliament and of the Council on machinery.

Manufacturer/ SCHUNK GmbH & Co. KG Spann- und Greiftechnik
Distributor Bahnhofstr. 106 – 134
D-74348 Lauffen/Neckar

We hereby declare that on the date of the declaration the following incomplete machine complied with all basic safety and health regulations found in the directive 2006/42/EC of the European Parliament and of the Council on machinery. The declaration is rendered invalid if modifications are made to the product.

Product designation: Electric Tool Changer / EWS / elektric
ID number EWK: 1000401, EWA: 1000419

The incomplete machine may not be put into operation until conformity of the machine into which the incomplete machine is to be installed with the provisions of the Machinery Directive (2006/42/EC) is confirmed.

The manufacturer agrees to forward on demand the relevant technical documentation for the partly completed machinery in electronic form to national authorities.

The relevant technical documentation according to Annex VII, Part B, belonging to the partly completed machinery, has been created.

Person authorized to compile the technical documentation:
Robert Leuthner, Address: see manufacturer's address

Signature: see original declaration

Lauffen/Neckar, September 2016

p.p. Ralf Winkler,
Head of Gripping Systems Development

