

Montage- und Betriebsanleitung Installation- and operating instruction

Kraftverstärkter Teleskopspanner Telescopic vice with force amplification

KSX



H.-D. SCHUNK GmbH & Co.
Spanntechnik KG
Lothringer Strasse 23
88512 Mengen

Table of contents:





1	User information	18
1.1	Purpose of document	18
1.2	Illustration of safety features	18
2	General safety instructions	19
2.1	Intended use	19
2.1.1	Technical data	19
2.2	Reasonably foreseeable misapplication	19
2.2.1	Alterations and modifications.....	19
2.2.2	Spare and wear parts and auxiliary material.....	19
2.3	Residual risk	20
2.3.1	Jaw change	20
2.3.2	Notes on clamping technology.....	20
2.4	Duties of the organisation in charge.....	20
2.5	Operator duties.....	21
2.6	Operator qualification	21
2.7	Personal protective equipment.....	21
2.8	Warranty	21
3	Description	22
3.1	Function.....	22
4	Operation	23
4.1	Clamping / aligning	23
4.2	Jaw range	23
4.2.1	Installation the system jaws.....	23
5	Servicing, cleaning and maintenance	24
6	Troubleshooting / Eliminating faults	24
7	Removing / Assembly	25
8	Assembly drawing	28
8.1	Parts list.....	28
9	Swivel and adapter plate	29
9.1	Function.....	29
9.2	Servicing, cleaning and maintenance.....	29
9.3	Troubleshooting / Eliminating faults	29
9.4	Removing and replacing parts	30
9.5	Fitting the 6-fold reversible jaws.....	30
10	Aluminium jaw	30
11	Pull rod extension	31
11.1	Alignment of base body extension	31
12	Taking out of service	31

1 User information

1.1 Purpose of document

These instructions are an integral part of the product supplied and contain important information for the safe installation, commissioning, operation, servicing and maintenance. These instructions must be read before using the product and must be observed during operation, in particular the "General safety instructions" section.

1.2 Illustration of safety features

DANGER	
	<p>Indicates imminent danger. If the information is ignored, death or serious injury (permanent disability) will result.</p>
WARNING	
	<p>Indicates a potentially dangerous situation. If the information is ignored, it is possible that death or serious injury (permanent disability) will result.</p>
WARNING	
	<p>Indicates a potentially dangerous situation. If the information is ignored, it is possible that material damage and light to medium injury will result.</p>
NOTE	
	<p>Indicates general information, useful tips for users and work recommendations which do not impact on the health and safety of operators. ... underscores useful tips and recommendations as well as information for efficient and trouble-free operation.</p>
CAUTION	
	<p>Indicates a potentially dangerous situation. If the information is ignored, material damage will result. ... points out a potentially dangerous situation that can lead to material damage if it is not avoided.</p>

2 General safety instructions

2.1 Intended use

The clamping device may only be used in accordance with the technical data and has been designed for stationary application on milling machines in an industrial environment.

Using the device in accordance with the intended purpose includes compliance with the commissioning, installation and operating instructions, and with the environmental and service conditions as provided by the manufacturer.

The manufacturer accepts no liability for damage resulting from non-intended use.

2.1.1 Technical data

Version	min. clamping force	max. clamping force
KSX	5 kN	40 kN

Weight:

KSX without system jaws: 30.2 kg

KSX low high without system jaws: 22.6 kg

KSX low high short without system jaws: 21.0 kg

For further data, please see homepage >> schunk.com <<

2.2 Reasonably foreseeable misapplication

Any application that is not in accordance with the "Intended use" or exceeds such intended use is considered not in accordance with the regulations, and is forbidden. Any other use of the device is subject to confirmation from the manufacturer.



Examples of foreseeable misapplication

- Clamping device used on rotating systems.
- Clamping widely protruding workpieces.
- Clamping workpieces with a weight of over 20 kg in vertical position without an additional protection against the workpiece falling out as a protective measure for the operator.

2.2.1 Alterations and modifications

In the case of unauthorised alterations and modifications of the clamping device, the manufacturer's liability ceases and any warranty is voided.

2.2.2 Spare and wear parts and auxiliary material

Only use original parts or parts approved by the manufacturer.

Using spare and wear parts by third party manufacturers may lead to risk.

2.3 Residual risk

The user is responsible for applying the correct workpiece clamping.

New clampings have to be carefully checked by qualified personnel with relevant training.

One always needs to allow for the risk that the workpiece may slip or be dislodged, even when the clamping device is functioning correctly. This is due to the different geometries to be clamped, contact surfaces, clamping friction values, processing force, wrong manipulation of the milling machine etc.

Protective devices are to be attached to the processing machine that will protect the operator from any tool or workpiece parts that may be ejected.

It is mandatory that operators and others in the proximity of the processing machine wear protective goggles.

Do not use methods of operation that impair the function and operational safety.



2.3.1 Jaw change

Damage may result if system jaws are insufficiently tightened.



2.3.2 Notes on clamping technology

The operator is responsible for ensuring that the clamping geometry and clamping forces are suitable for the intended processing.

The clamping forces can only be achieved if the clamping device functions correctly and the workpiece is correctly held in the device.

Regular servicing and cleaning in accordance with the operating instructions is mandatory in order to ensure correct function.

When clamping thin-walled elastic workpieces, e.g. tubes or packages, it is possible that the clamping force is significantly reduced due to yielding of the workpiece.

When clamping with a high degree of force, the clamping force is significantly reduced due to the increased frictional forces in the slider.

2.4 Duties of the organisation in charge

The organisation in charge of the device undertakes to only allow operatives to work on the device:

- who are familiar with the basic health and safety regulations and regulations for the prevention of accidents.
- who have completed appropriate induction for working with the machine.
- who have read and understood these operating instructions.

The requirements of the EC Directive 2007/30/EC on the use of work machinery must be complied with.

2.5 Operator duties

All persons who have been instructed to work with the machine undertake to:

- observe the basic regulations for health and safety and for the prevention of accidents.
- read and understand the section on safety and the safety instructions in these operating instructions prior to working with the machine, and to observe these instructions.

2.6 Operator qualification

The installation, initial setup, fault analysis and periodic monitoring have to be carried out by competent personnel with the relevant qualifications.

2.7 Personal protective equipment

WARNING	
	<p>Ejected hot fragments can lead to serious eye injury. The regulations for safety at work and the prevention of accidents always have to be observed when working with the machine.</p> <p>Personal protection equipment must be worn at all times, in particular safety boots, gloves and safety goggles.</p>

2.8 Warranty

Warranty	24 months
Maximum service life	50'000 clamping cycles

The warranty period is valid from the date of delivery ex-works, provided the machine is used as intended and subject to the following conditions:

- Compliance with the concurrent documents.
- Observance of environmental and work conditions.
- Observance of the specified servicing and lubrication intervals.
- Observance of the maximum service life.

Parts in contact with the workpiece are not covered by the warranty.

3 Description

The KSX has been designed for clamping unprocessed and processed workpieces. The spindle is operated with a telescopic function and is protected against dirt thanks to complete encapsulation.

The operating torque of the lever is approx. 50 Nm for a clamping force of 40 kN.

Upon actuation of the clamping lever for the force structure is important to ensure that the clamping movement is performed with a normal, smooth turn.

Jerky or very fast motion can lead to increased tension forces that may overload the system.

Inappropriate application or applying too much force to the drive either by impact or with extended levers lead to damage to the spindle and mechanical force cassette.

The KSX may only be operated using the original clamping lever.



3.1 Function

The clamping force is generated mechanically, with a force amplifier and linear across the whole clamping range.

The clamping forces are variable and can be adjusted between 5 and 40 kN using the setting ring.

The clamping range can be quickly adjusted by turning the spindle with a hand crank.

The KSX can be extended for an even larger clamping range with additional extensions.

4 Operation

4.1 Clamping / aligning

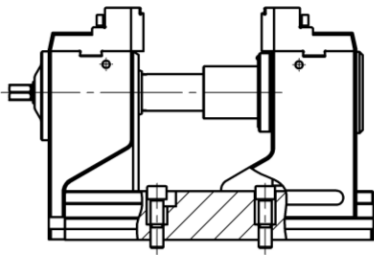

Alignment with precision slot nuts or cylinder pins on the T-slot machine table and the cross slots 20 H7 or the positioning holes in the base body.
Fastening on grid plate with two fitting screws $\varnothing 12$ f7/M12 through positioning hole in the base body with distance of 100mm.

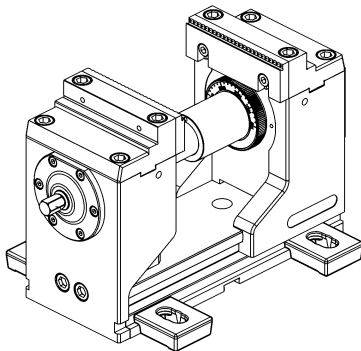

Fastening with clamping claws.

Important:

Symmetrical distance of the two clamping claws is 100 to 150 mm to the center of the vice.

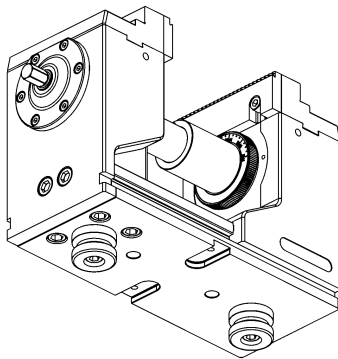

Locating holes $\varnothing 25$ H6 to attaching the clamping pins for NSE3 and GFD quick-change pallet systems.

4.2 Jaw range

The reliable function of the clamping device is significantly affected by the selection of the correct top jaws.

4.2.1 Installation the system jaws

Use only cylinder screws (12.9) and tighten them with a torque of 105 Nm.



5 Servicing, cleaning and maintenance

No special servicing is required as the spindle unit is fully encapsulated.

Grease the guides of the moving clamping jaw with machine oil at regular intervals (every two weeks). This is done by moving the clamping jaw from the work position.

Cleaning / Lubrication

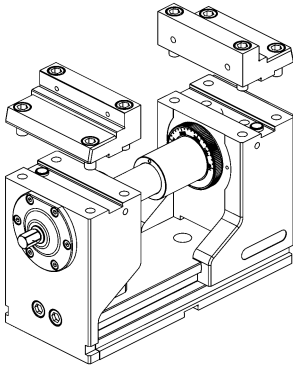

- Remove jaws.
- Clean and oil contact surfaces.
- Move the moving jaw to the front stop.
- Clean and oil surfaces, e.g. with MOTOREX Supergliss 68 K.
- Move the moving jaw to the rear stop.
- Clean and oil the remaining parts of the surfaces.
- Clean and oil the outside surfaces of the spindle.



6 Troubleshooting / Eliminating faults

Vice is hard to operate

Dismantle, clean and the damaged surfaces must be carefully levelled off with a honing stone.

Setting ring for force adjustment has turned loose

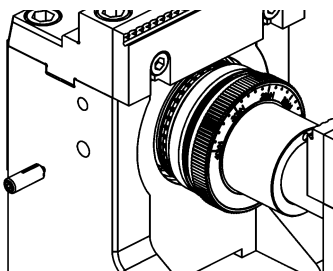

- Turn the spring-loaded pressure piece three times to turn out.
- Turn in the setting ring up to the stop.
- Turn the spring-loaded pressure piece three times to turn in.

Setting ring for force adjustment cannot be turned

- Turn out the spring-loaded pressure piece until the setting ring can be turned again.
- Lubricate the setting ring seals.

Important:

The clamping force can only be adjusted when no tension is applied.

The setting ring for force adjustment does not hold its position

- Turn in the spring-loaded pressure piece until engagement of the setting ring can be felt. (at a depth of approx. 7 – 7.5 mm).

Spindle difficult to turn

- Dismantle and clean spindle.
- Check the thread for any damage.
- Lubricate and re-assemble the spindle.

Force amplification is too hard or too easy to operate

- Move jaws 20 - 30 mm apart and back together. (approx. 5 - 6 spindle turns)
- Adjust clamping force (if possible) by 15 - 20 kN.
- Repeat clamping and unclamping process 3 – 4 times.
- Re-set force setting to the required value.
- If necessary, dismantle and clean spindle.

7 Removing / Assembly

Removing the turn prevention lock

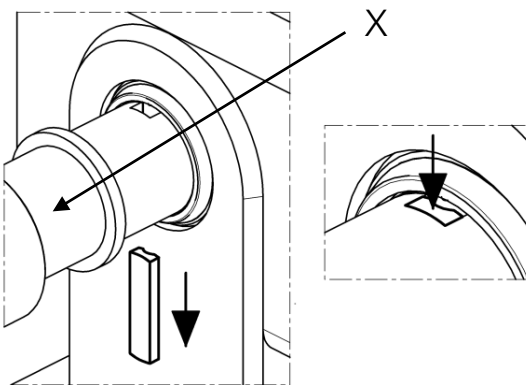

- Slightly push back the damping ring X.
- Turn the spindle until the groove of the turn prevention lock can be seen from above.
- Use a screwdriver or Allen key to push the turn prevention lock downwards until it comes out.

Replacing the turn prevention lock

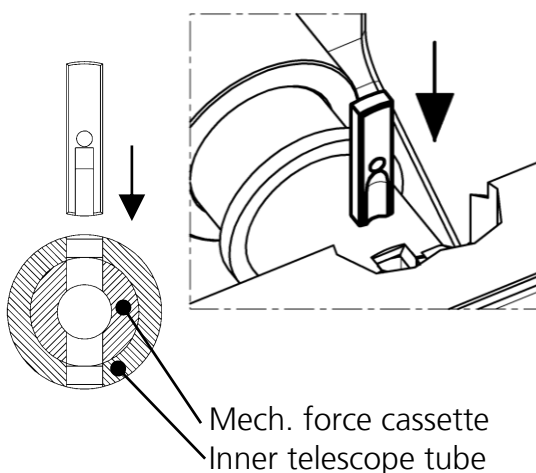

- Turn in the mechanical force cassette and inner telescope tube up to the stop.
- Turn the mechanical force cassette and inner telescope tube back so that both grooves are aligned.
- Insert the turn prevention lock, push the damping ring X back in place on the prevention lock.

Important:

Always insert the turn prevention lock engaging the recessed end first. The recess must be pointing towards the fixed jaw.



Removing the movable jaw

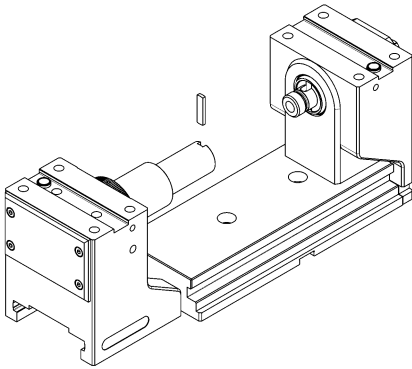

- Remove the turn prevention lock.
- Turn the spindle until the movable jaw is free.
- Pull the jaw from the base body.

Removing the spindle

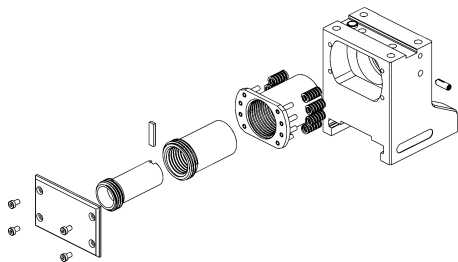

- Clamp the KSX in order to release the cover plate.
- Remove cylinder screws NK M6x10.
- Remove cover plate.
- Unclamp the KSX.
- Remove the turn prevention lock.
- Turn out the inner and middle telescope tubes.
- Remove the outer telescope tube.

Caution:

The cover plate is spring loaded. Removing the cover plate in de-clamped position is only possible with great force!

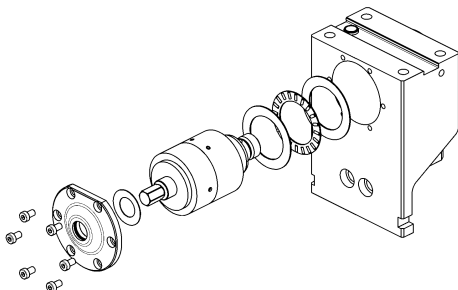

Removing the mechanical force cassette

- Remove cylinder screws NK M6x10.
- Remove the cover from the spindle.
- Remove the spring washer.
- Pull the mechanical force cassette from the fixed jaw.
- Remove axial needle cage and washers.

Important:

The mechanical force cassette is spring tensioned and may only be opened by qualified personnel!

Further dismantling is only possible with special tools.

Please contact your manufacturer if you wish to replace the mechanical force cassette.



When installing the mechanical force cassette into the fixed jaw it is necessary to refill it with low-viscosity gear grease, preferably with a large syringe, to ensure sufficient lubrication!

Low-viscosity gear grease: e.g. with MOTOREX GLYCO GEAR ISO VG 220

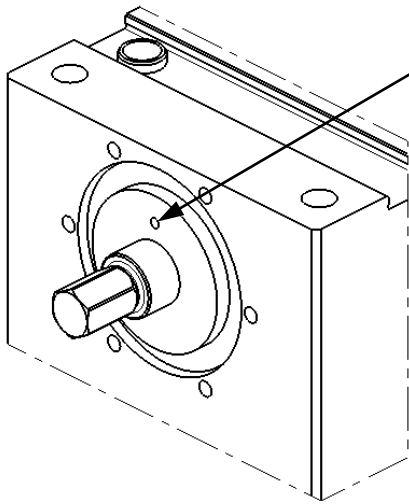

Filling through the hole in the mechanical force cassette.

- Filling amount in already used mechanical force cassette: 10 - 15 ml.
- Filling amount in a new mechanical force cassette: 50 - 55 ml.

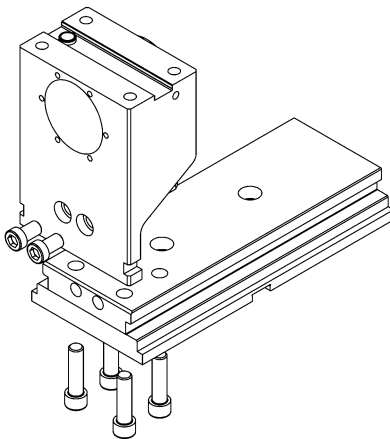

Removing the fixed jaw

- Release 4 cylinder screws M12x45.
- Release 2 cylinder screws NK M12x20.
- Remove the fixed jaw.

Replacing the fixed jaw

- Align the fixed jaw with the outside of the base body.
- Insert the four cylinder screws M12x45 with 120 Nm and two cylinder screws M12x20 with 65 Nm in crosswise sequence Tighten screws.

Assembly

The assembling steps are performed in reverse order to disassemble.

For the assembly it is important to ensure that the sealing rings are correctly inserted into the fixed jaw and the spindle. Apply adequate lubrication to all components during assembly.

Important:

The threaded parts of the telescope tubes may only be oiled, e.g. with MOTOREX Supergliss 68 K and not lubricated with grease.

The torque to be used for the cylinder screws M6x10 NK 8.8 for the cover is 10 Nm.



8 Assembly drawing

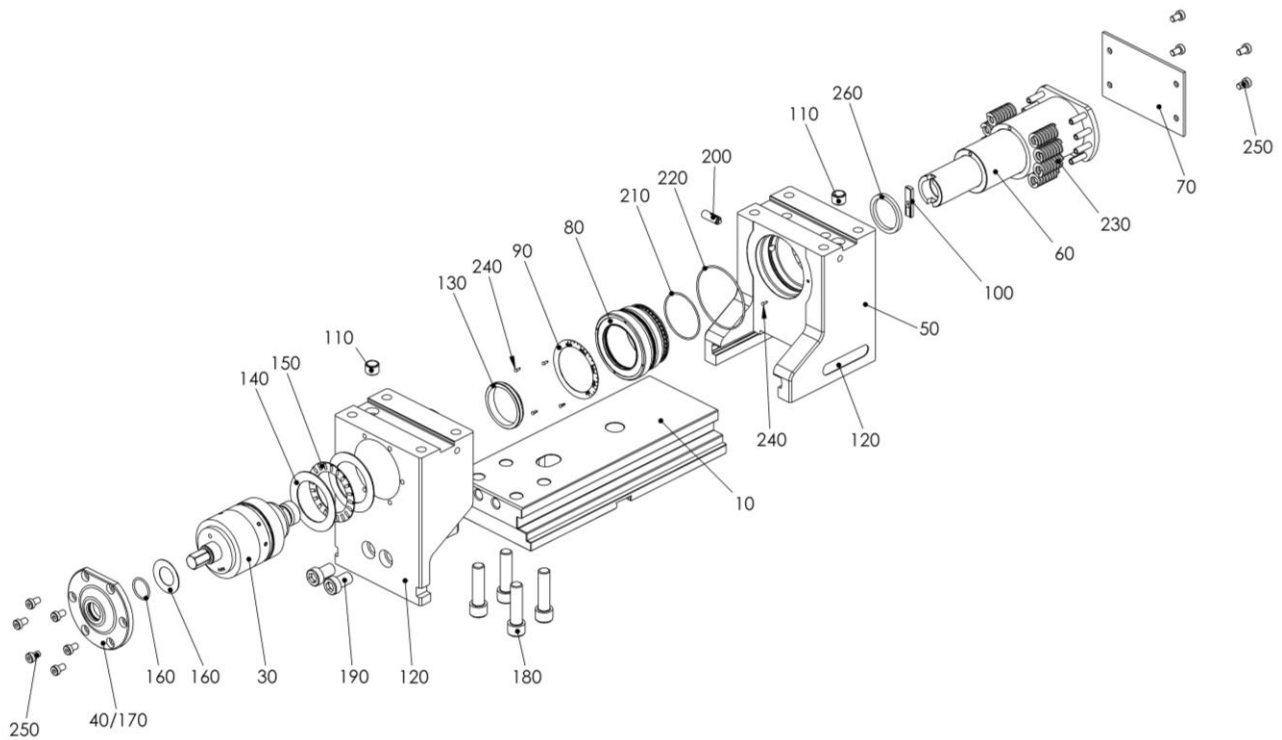

8.1 Parts list

Position	Part. No.	Designation	Quantity
10	TFS.125.002.11 <i>TFS.125.103.11</i>	Base body (TFS.125.001.01 and TFS.125.101.01) Base body S/265 (TFS.125.102.01)	1
20	TFS.125.021.11 <i>TFS.125.055.11</i>	Fixed support jaw (TFS.125.001.01) Fixed support jaw low (<i>TFS.125.101.01, TFS.125.102.01</i>)	1
30	TFS.125.008.01	Mechanical force cassette	1
40	TFS.125.028.11	Cover	1
50	TFS.125.004.11 <i>TFS.125.054.11</i>	Movable support jaw (TFS.125.001.01) Movable support jaw low (<i>TFS.125.101.01, TFS.125.102.01</i>)	1
60	TFS.125.051.01	Telescope spindle complete	1
70	TFS.125.007.11	Cover plate	1
80	TFS.125.052.11	Setting ring	1
90	TFS.125.053.11	Scale ring	1
100	TFS.125.015.11	Turn prevention lock	1
110	DXM.100.010.11	centering	2
120	TFS.125.011.11	Type plate	2
130	XNN.65110.420	Wiper ring	1
140	XNN.20475.456	Axial washer	2
150	XNN.20470.456	Axial needle cage	1
160	XNN.30050.351	Spring washer	1
170	XNN.61072.033	O-ring NBR/70 20.35x1.78	1
180	XNN.10311.524	Internal hexagon cylinder screw M12x45 12.9	4
190	XNN.10361.513	Internal hexagon cylinder screw NK M12x20	2
200	XNN.90012.080	Spring-loaded pressure piece M8	1
210	XNN.61074.803	O-ring NBR/70 48.00x1.50	1
220	XNN.61075.052	O-ring NBR/70 53.70x1.78	1
230	XNN.30030.017	Spiral spring	8
240	XNN.18210.106	Grooved pin Ø2x6	5
250	XNN.10361.358	Internal hexagon cylinder screw NK M6x10	10
260	TFS.125.018.11	Damping ring	1

9 Swivel and adapter plate

9.1 Function

Slanted and curved items can be securely clamped with 4-point clamping using the protected O-ring swivel plate system.

The swivel plate is pulled downwards during the clamping process due to its conical swivel plate bearings, this means that the swivel plate is not likely to lift off.

With the 6-fold reversible jaw it is possible to cover numerous clamping solutions in a straight-forward way. A total of six different clamping sides are available, at the four sides of the jaw as well as at two places with a convex "grip" profile.

It is also possible to carry out two-sided processing using the tungsten carbide coated side of the 6-fold reversible jaw.

Processing the first side

For unprocessed part clamping using the 6-fold reversible jaw, five different "grip" clamping sides are available with a clamping depth of 3, 8 and 18 mm.

Processing the second side

Clamping with the tungsten carbide coated side of the 6-fold reversible jaw.

It is important to take into account that during the first clamping process, the 6-fold reversible jaws can yield slightly until the play in the peg seating is eliminated.

The workpiece position must be measured, the zero point should not be determined until after 3 to 5 power clampings.

Handling the demounted swivel plate

The conical swivel peg can be pulled out since it is only held in position by an O-ring in the counter direction. When handling the swivel plate, it should not be turned upside down since this could cause the peg to fall out.



9.2 Servicing, cleaning and maintenance

The upper shoulder of the swivel peg must be greased regularly.

Turn the swivel plate once a week so that the lubrication film can be rebuilt.

Lubrication of the swivel peg is recommended once a year.

9.3 Troubleshooting / Eliminating faults

Swivel plate is difficult to turn

- Disconnect the swivel plate and push the swivel peg from below out of the swivel plate.
- Check the vice guide and swivel plate surface for indentations or deformations. If necessary, re-grind the plate and the vice guide.
- Check the peg for soiling.
- Check that the O-rings are correctly positioned. The upper O-ring must make good contact.
- Lubricate the entire system with grease and reassemble.

9.4 Removing and replacing parts

- Release cylinder screws and remove the jaws.
- Clean and oil the contact surfaces, e.g. with MOTOREX Supergliss 68 K.
- Place the adapter plate on to the fixed jaw and Tighten the cylinder screws M12x25 with 65 Nm in crosswise sequence.
- Place the swivel plate on to the movable jaw and tighten the cylinder screws M12x25 with 65 Nm.

9.5 Fitting the 6-fold reversible jaws

- Determine the mounting positions of the 6-fold reversible jaws.
The best clamping results are achieved when workpieces as far out as possible.
- Move the cover screws so that the selected clamping position is available.
- Position the 6-fold reversible jaws and loosely insert the cylinder screws.
- Turn the 6-fold reversible jaws to the required clamping surface and slightly pre-clamp the workpiece so that the clamping faces are parallel to the workpiece.
- Use a torque of 80 Nm to tighten the cylinder screws of the 6-fold reversible jaws.

Important:

When the clamping faces of the 6-fold reversible jaws are not aligned parallel to the workpiece surface it is possible that the 6-fold reversible jaw becomes loose through the clamping force.



10 Aluminium jaw

Put aluminium jaw in place and tighten the cylinder screws M12x20 with 65 Nm in crosswise sequence.

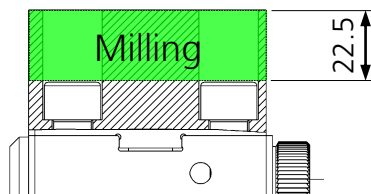

Important:

The milling depth in the cylinder screw area must not be more than 22.5 mm!



11 Pull rod extension

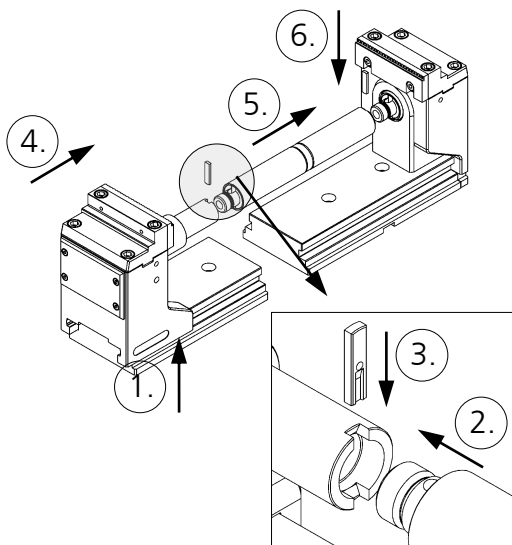

1. Installation the base body extension.
(for alignment, see 11.1)
2. Screw the pull rod extension to the spindle.
3. Insert the first turn prevention lock.
4. Slide the support jaw on to the base body Extension.
5. Attach the pull rod extension to the fixed jaw.
6. Insert the second turn prevention lock.

The disassembly is carried out in reverse order.

11.1 Alignment of base body extension

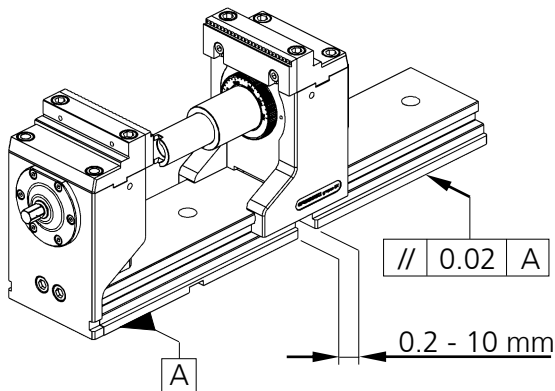

1. Loosely fit the base body extension with a distance 0.2 - 10 mm to base body.
2. Slide the movable support jaw on so that it covers both base bodies.
3. Align the base body extension parallel to the base body.
4. Fix the base body extension.

12 Taking out of service

The clamping device and all accessories can be disposed of as scrap metal without any risk.



H.-D. Schunk GmbH & Co.
Spanntechnik KG
Lothringer Strasse 23
D-88512 Mengen

Tel.: +49-7572-7614-1300
Fax: +49-7572-7614-1039

CMM@de.schunk.com
schunk.com