

Robot coupling for pallet handling

VERO-S NSR 160 / PKL 160

Assembly and Operating Manual

Translation of Original Operating
Manual

Hand in hand for tomorrow

Imprint

Copyright:

This manual is protected by copyright. The author is SCHUNK SE & Co. KG.
All rights reserved.

Technical changes:

We reserve the right to make alterations for the purpose of technical improvement.

Document number: 0489066

Version: 08.00 | 18/08/2025 | en

Dear Customer,

Thank you for trusting our products and our family-owned company, the leading technology supplier of robots and production machines.

Our team is always available to answer any questions on this product and other solutions. Ask us questions and challenge us. We will find a solution!

Best regards,

Your SCHUNK team

Customer Management

Tel. +49-7572-7614-1300

Fax +49-7572-7614-1039

cmm@de.schunk.com



Please read the operating manual in full and keep it close to the product.

Table of Contents

1	General	5
1.1	About this manual.....	5
1.1.1	Illustration of safety notes	5
1.1.2	Applicable documents	5
1.2	Warranty	6
1.3	Scope of delivery.....	6
1.3.1	Accessories	6
2	Basic safety notes.....	7
2.1	Intended use.....	7
2.2	Not intended use	7
2.3	Notes on particular risks	8
2.4	Notes on safe operation.....	10
2.4.1	Holding force and screw strength	11
2.4.2	Constructional changes.....	11
2.4.3	Spare parts	11
2.5	Personnel qualification	11
2.6	Using personal protective equipment	11
2.7	Organizational measures.....	12
2.8	Environmental and operating conditions.....	12
2.9	Material limitations	13
2.10	Transport.....	13
2.11	Protection during handling and assembly	13
2.12	Protection during commissioning and operation	13
2.13	Disposal	13
2.14	Fundamental dangers	13
3	Technical data	14
3.1	Robot coupling NSR 160	14
3.2	Calculation of Permissible Transport Load	15
4	Assembly.....	17
4.1	Screw tightening torques	17
4.2	General installation notes	18
4.3	Fixing and connection.....	18
4.3.1	Unlocking connection.....	22
4.3.2	Turbo connection	22
4.3.3	Air purge connection with cleaning function	22
4.3.4	Pneumatic circuit diagram	23
4.4	Coupling interface	25
4.4.1	Pallet coupling PKL 160	26

4.5 Tolerances and Installation Conditions for SPA 40-16 Clamping Pins in Customer-Specific Pallet Coupling	30
4.6 Application example for automated pallet loading	32
4.6.1 Connection and disconnection of transport loads	33
5 Maintenance and Care	34
5.1 Regular Inspection of Robot and Pallet Coupling	35
6 Storage.....	36
7 Troubleshooting.....	37
8 Seal kit and part lists	38
8.1 Sealing Kit List.....	38
8.2 Part list.....	38
9 Assembly drawings	40
10 Sensors.....	43
11 Manufacturer certificate.....	48

1 General

1.1 About this manual

This manual contains important information for the safe, correct use of the product.

It is an integral part of the product and must be kept accessible for personnel at all times.

Personnel must have read and understood this manual before beginning any work. The observance of all safety notes in this manual is a prerequisite to ensure safe work processes.

The illustrations are intended to provide a basic understanding and may deviate from the actual version.

Besides this manual, other documents which apply are those listed under ▶ 1.1.2 [5]

1.1.1 Illustration of safety notes

To make risks clear, the following signal words and symbols are used for safety notes.



⚠ DANGER

Denotes a hazard with a high degree of risk that, if not avoided, will result in death or serious injury.



⚠ WARNING

Denotes a hazard with a medium degree of risk that, if not avoided, could result in death or serious injury.



⚠ CAUTION

Denotes a hazard with a low degree of risk that, if not avoided, could result in a minor or moderate injury.

NOTICE

Information about avoiding material damage.

1.1.2 Applicable documents

- General Terms and Conditions *
- Catalog data sheet for the attached product *
- Technical data sheet for optional attachments *
- Approval drawings

The documents labeled with an asterisk (*) can be downloaded from **schunk.com**.

1.2 Warranty

The warranty for standard products is 24 months from the date of delivery from the factory, or 50,000 cycles* for manually operated clamping devices and 500,000 cycles* for power operated clamping devices. For special clamping devices, it is 12 months from the date of delivery from the factory, assuming appropriate use in accordance with the following conditions:

- Observe the applicable documents, ▶ 1.1.2 [5]
- Observance of the ambient conditions and operating conditions
- Observe the care and maintenance instructions

Parts touching the workpiece and wearing parts are not covered by the warranty.

* One cycle comprises one complete clamping procedure ("opening" and "closing").

1.3 Scope of delivery

The scope of delivery includes

- Robot Coupling for Pallet Handling in the version ordered
- Accessory kit
- Assembly and Operating Manual

1.3.1 Accessories

(see catalog or data sheets when ordering separately)

NSR 160–84 accessories

- Pallet coupling PKL–K 160 (PKL 160 or PKL 160 Lean can optionally be used)
- Clamping pin
- Proximity switch MMS 22–SA
- Proximity switch IN 50
- Clamping pallets
- Protection cover SDE 40
- Pneumatic screw connections

NSR 160–84 accessories

- Clamping pin
- Proximity switch IN 50
- Proximity switch MMS 22–SA (included in scope of delivery)
- Pneumatic screw connections (included in scope of delivery)

2 Basic safety notes

Improper handling, assembly and maintenance of this product may result in risk to persons and equipment if this operating manual is not observed.

Report any failures and damage immediately and repair without delay to keep the extent of the damage to a minimum and prevent compromising the safety of the product.

Only original SCHUNK spare parts may be used.

2.1 Intended use

The VERO-S robot coupling is intended for pallet handling with a robot or similar appropriate technical devices. It is intended for automatic loading of tool machines or other appropriate technical devices.

The product may only be used on the basis of its technical data. The specified maximum technical data must not be exceeded during use.

The product is designed for industrial use.

To use this unit as intended, it is also essential to observe the technical data and installation and operation notes in this manual and to comply with the maintenance intervals.

2.2 Not intended use

The VERO-S robot coupling for pallet handling is not being used as intended if, for example:

- It is used as load handling or lifting equipment.
- the product is used for turning applications over 100 RPM without consulting SCHUNK.
- It is used in working environments that are not permissible.
- the product is not fully covered by the pallet, the fixture or the workpiece.
- the product is brought into contact with aggressive media, especially acids.
- the product is used in abrasive blasting processes, especially sandblasting.
- People work on machines or technical equipment that do not comply with the EC Machinery Directive 2006/42/EC, disregarding the applicable safety regulations.
- The technical data specified by the manufacturer for using the robot coupling and the pallet coupling is exceeded.

2.3 Notes on particular risks

- Disconnect the power supply lines and ensure that there is no residual energy in the system before performing assembly, modification, maintenance, or adjustment work.
- Do not move parts by hand when the energy supply is connected.
- Perform maintenance, modifications, or installations outside of the danger zone.
- For all work, secure the system against accidental operation.
- Do not reach into the open mechanism or the movement area of the system.
- Only specialist personnel may perform assembly, modification and disassembly work.



⚠ WARNING

Risk of injury due to falling device, pallet or workpiece if the clamping pin is loosened erroneously or as a result of negligence.

- During operation, erroneous or negligent loosening of the clamping pin must be prevented using suitable countermeasures (disconnecting the power supply after locking, use of check valves or safety switches).
- Check the screw fitting of the clamping pin on the pallet coupling at regular intervals to ensure that it is secure.
- In pallet handling setup mode, only one operator may generally work on the robot system.
- Do not step under raised loads in the robot or automation system (clamping pallet connected).



⚠ WARNING

Risk of injury to operating personnel due to movement of robot arm.

Risk of injury due to uncontrolled movements during robot coupling setup and during operation.

- During robot coupling setup, accidental actuation of the robot arm must be prevented by suitable countermeasures.
- The machines and equipment must fulfill the minimum requirements of the EC Machinery Directive 2006/42/EC; specifically, they must have effective technical measures to protect against potential mechanical hazards.



⚠ WARNING

The system clamps using spring force. Risk of injury due to parts automatically moving to their end positions following actuation of an "emergency stop" or after switching off the power supply.

- Wait for the system to shut down completely.
- Do not reach into the clamping module.
- Use pressure maintenance valves.



⚠ CAUTION

Risk of injury due to compressed air hoses coming loose when connected improperly.

- Use check valves or safety switches.
- The danger zone must be surrounded by a protective enclosure during operation.



⚠ CAUTION

Risk of slipping or falling if the operational environment is not clean (e.g. contaminated with cooling lubricants or oil).

- Ensure that the working environment is clean before starting assembly and installation work.
- Wear suitable safety boots.
- Follow the safety and accident prevention regulations when operating the robot coupling, especially when working with machine tools and other technical equipment.



⚠ CAUTION

Risk of burns due to workpieces with high temperatures.

- Wear protective gloves when removing the workpieces.
- Automatic loading is preferred.



⚠ CAUTION

Danger from noise generation

Physical and mental stress by noise generation during the working process.

- Wear hearing protection.

2.4 Notes on safe operation

The robot coupling may pose a danger to persons (risk of injury) and property if, for example:

- it is not used as intended;
- it is not installed or maintained properly;
- The safety and installation instructions, local applicable safety and accident prevention regulations or the Machine Directive are not observed.

NOTES

During automated loading or unloading, particularly with high loading weights, always work with the handling system at reduced speed. The handling system must be positioned and fastened precisely to guarantee that the connection is not offset.

Check the approach position of the handling system at regular intervals. The position of the handling system can change slightly, particularly with high load weights or when the clamping pallet is bearing the loading weight significantly towards the front. In the event of eccentricity on the coupling interfaces, the relevant traveling axes of the handling system must be adjusted. The robot coupling must lie flush with the pallet coupling with no tilt angle and eccentricity when joining. A rigid handling system must be used with high loading weights. For the automated coupling process, it is advisable to use the air purge to clean the coupling interface.

The pallet handling should be moved out of the machining area once pallet loading is complete. If the clamping system is left in the working area, it must be protected against dirt entering the interface..

Maintenance specifications

Follow the maintenance and care instructions. These instructions are based on a normal working environment. If the robot coupling is to be operated in an environment with abrasive dusts or corrosive or caustic fumes or fluids, prior approval must be obtained from SCHUNK.

Safety during assembly and servicing

During assembly, connection, adjustment, commissioning and testing, make sure that no accidental operation of the robot coupling by the fitter or other persons is possible.

Avoid any unsafe manner of working.

2.4.1 Holding force and screw strength

The holding force of the robot coupling is essentially limited by the tightness of the screw connection which connects the clamping pin to the pallet coupling or device. This is why only screws of strength class 12.9 may be used.

Only original SCHUNK clamping pins may be used.

If the clamping pin is to be used in customer-specific devices, the customer must provide a sufficiently dimensioned pallet coupling or a sufficiently thick mounting material.

2.4.2 Constructional changes

Implementation of structural changes

Modifications, changes or reworking, e.g. additional threads, holes, or safety devices, can damage the product or impair its functionality or safety.

- Structural changes should only be made with the written approval of SCHUNK.

2.4.3 Spare parts

Use of unauthorized spare parts

Using unauthorized spare parts can endanger personnel and damage the product or cause it to malfunction.

- Only use original spare parts and spares authorized by SCHUNK.

2.5 Personnel qualification

The robot coupling must only be installed, removed, started up, operated and serviced by qualified specialist personnel with the relevant safety training.

All persons charged with operating, maintaining and servicing the robot coupling must have access to the operating manual, especially the chapter "Basic safety notes". We recommend that the operator creates in-house safety operating instructions.

Trainees may work on machines and technical equipment in which the robot coupling is installed, provided that they are supervised at all times by qualified specialist personnel.

2.6 Using personal protective equipment

When using this product, you must conform with the relevant health & safety at work rules and you must use the required personal safety equipment.

- Use safety gloves, safety shoes, hearing protection and safety glasses.
- Maintain safe distances.
- Comply with the minimum safety requirements for the use of equipment.

2.7 Organizational measures

Obeying the rules

The operator must employ suitable organizational measures and instructions in order to ensure that the relevant safety rules are obeyed by the persons asked to operate, maintain and repair the product.

Monitoring the behavior of personnel

The operator must at least occasionally check that the personnel are behaving in a safety-conscious manner and are aware of the potential hazards.

Danger signs

The operator must ensure that the signs concerning safety and hazards on the machine where the product is mounted are clearly legible and are observed.

Faults

If a malfunction occurs in the product and endangers safety, or if a problem is suspected due to production behavior, the machine on which the product is mounted must be stopped immediately and remain shut down until the malfunction has been located and remedied. Only allow specialists to remedy malfunctions.

Spare parts

Only use original SCHUNK spare parts.

Environmental regulations

The applicable environmental regulations must be observed for all maintenance and repair work.

2.8 Environmental and operating conditions

Required ambient conditions and operating conditions

Incorrect ambient and operating conditions can make the product unsafe, leading to the risk of serious injuries, considerable material damage and/or a significant reduction to the product's life span.

- Make sure that the product is used only in the context of its defined application parameters, ► 3.1 [14].
- Make sure that the product is a sufficient size for the application.
- Make sure that the contact surfaces of the interface are always clean.
- Make absolutely sure that no chips of any kind can enter the interface and that the interface does not fill with cooling emulsion, which is particularly possible with vertical positioning of the clamping pin axis. The best way to ensure both of these is to use the SDE protection covers. If the interface should fill with cooling emulsion, initiate the unlocking process and dry out the interface in actuated state.
- Only use high-quality cooling emulsions with anti-corrosive additives during processing.

2.9 Material limitations

The product is made of steel alloys, elastomers and aluminum alloys. In addition, Branotect anti-rust oil and Renolit HLT2 are incorporated into the product as auxiliary and operating materials.

2.10 Transport

Handling during transport

Incorrect handling during transport can make the product unsafe and risks the danger of serious injuries and considerable material damage.

- During transport and handling, secure the product to prevent it from falling.

2.11 Protection during handling and assembly

Incorrect handling and assembly

Incorrect handling and assembly can make the product unsafe and can risk the danger of serious injuries and considerable material damage.

- All work must only be performed by appropriately qualified personnel.
- Secure the system against accidental operation during all work.
- Use suitable assembly and transport equipment and take precautions to prevent jamming and crushing.

2.12 Protection during commissioning and operation

Falling or violently ejected components

Falling and ejected components can lead to serious injury or death.

- Take suitable protective measures to secure the danger zone.

Manual loading

- If the clamping device is closed, the clamping pallet rests on the clamping slides after loading. When the clamping device is opened, the clamping pallet falls down. This poses a risk of crushing.

2.13 Disposal

Handling of disposal

Incorrect handling of disposal can make the product unsafe and lead to risks of environmental harm.

- Follow local regulations on dispatching product components for recycling or proper disposal.

2.14 Fundamental dangers

General

- Disconnect power sources before installation, modification, maintenance, or calibration. Ensure that no residual energy remains in the system.
- Do not reach into the open mechanism or movement area of the product during operation.

3 Technical data

3.1 Robot coupling NSR 160

Type designation	NSR 160	NSR 160-84
ID number	0471915	1320140
Max. torque Mx * [Nm]	600	960
Max. torque Mz * [Nm]		1600
Pull-down force without turbo [kN]		4.0
Pull-down force with turbo [kN]		15.0
Pull-down stroke [mm]		1.0
Actuation pressure [bar]		6
Min. Operating pressure [bar]		5
Repeat accuracy [mm]		< 0.02
Installation position		any
Operating temperature [°C]		5 – 60
Required level of cleanliness	IP 30 in accordance with DIN EN 60529	
Noise emission [dB(A)]	≤ 70	
Pressure medium	Compressed air, compressed air quality according to ISO 8573-1:2010 [6:4:4]	

* max. torque when fastening the clamping pin with cylindrical screw M16 – DIN EN ISO 4762/12.9 and full support on the module flat surface.

The directions of force for the maximum permissible torque are shown in the illustration in the chapter ▶ 4.4 [25].

The robot coupling NSR 160 is prepared for the monitoring of the following system states:

- OPEN and CLAMPED monitoring with 2 magnetic switches MMS 22-SA (to be ordered separately for NSR 160 / included in scope of delivery for NSR160-84)
- Pallet presence monitoring with a proximity switch IN 50 (to be ordered separately)

A separate maintenance unit must be used for the air supply. The robot coupling is prepared for use with unlubricated compressed air.

3.2 Calculation of Permissible Transport Load

The robot coupling is limited to a maximum permissible torque at the coupling interface. The dynamic load when using the robot system for handling results in acceleration and deceleration forces that have to be included in the transport load.

To operate the robot coupling for dynamic handling, it is essential for the maximum acceleration to be known.

The acceleration also has an effect with abrupt deceleration, e.g. after actuation of the emergency stop switch.

Inclusion of the acceleration values is of crucial importance for the operational safety of the robot coupling and the entire robot and palletizing system. If it is not taken into account, this can result in accidents and damage to the clamping system.

Calculation example for determination of permissible transport load

Missing information or specifications can be requested from the manufacturer.

Maximum permissible torque for NSR 160:

$$M = 600 \text{ Nm}$$

Legend	
M [Nm]	Torque
F [N]	Force
l [m]	Effective lever length from the coupling interface between the robot coupling and pallet coupling to the center of gravity of the load.
m [kg]	Mass
g [m/s ²]	Acceleration due to gravity
m _{tot} [kg]	m _{Pallet coupling} + m _{Clamping pallet} + m _{Transport load}
a [m/s ²]	Maximum acceleration of robot arm

Determination of formula values:

$$m_{\text{Pallet coupling, Type: PKL 160 (Aluminum)}} = 1.5 \text{ kg}$$

$$m_{\text{Clamping pallet, Type: PAL A 399 x 399 (Aluminum)}} = 11 \text{ kg}$$

$$m_{\text{Transport load}} = 200 \text{ kg (example value)}$$

$$l = 220 \text{ mm} = 0.22 \text{ m (example value)}$$

$$a = 3 \frac{\text{m}}{\text{s}^2}$$

Calculating the acceleration force:

$$\mathbf{F = m_{ges.} \cdot g + m_{ges.} \cdot a}$$

$$F = (1.5 \text{ kg} + 11 \text{ kg} + 200 \text{ kg}) \cdot 9.81 \frac{\text{m}}{\text{s}^2} + (1.5 \text{ kg} + 11 \text{ kg} + 200 \text{ kg}) \cdot 3 \frac{\text{m}}{\text{s}^2}$$

$$F = 212.5 \text{ kg} \cdot 9.81 \frac{\text{m}}{\text{s}^2} + 212.5 \text{ kg} \cdot 3 \frac{\text{m}}{\text{s}^2}$$

$$F = 2084.63 \text{ N} + 637.5 \text{ N}$$

$$\mathbf{F = 2722.13 \text{ N}}$$

$$\mathbf{M = F \cdot l}$$

$$M = 2722.13 \text{ N} \cdot 0.22 \text{ m}$$

$$\mathbf{M = 598.87 \text{ Nm}}$$

Maximum permissible torque for NSR 160: M = 600 Nm

Result of calculation:

Taking into account the robot acceleration, the loading weight obtained in the calculation example is permissible.

A higher loading weight requires a shortening of the effective lever length from the coupling interface to the center of gravity of the load, or a reduction in the robot acceleration.

For every change to the technical data, a calculation must be performed.

4 Assembly

Pre-assembly measures

Carefully lift the product out of the packaging (e.g. with suitable lifting equipment).



⚠ CAUTION

Risk of injury due to sharp edges and rough or slippery surfaces.

- Wear personal protective equipment, particularly protective gloves.

Check that the delivery is complete and that there is no transport damage.

Assembly of the robot coupling

Assembly, dismantling and modification work on the robot coupling may only be carried out by specialist personnel.

Disconnect the energy supply lines and ensure that there is no residual energy in the system when performing assembly, modification, maintenance, or adjustment work.

The hoses and cables required for the energy supply for the robot coupling must be laid and protected suitably on the pallet handling. Wear protective equipment (protective gloves and safety shoes).



⚠ WARNING

Risk of injury due to dropping the robot coupling during transport.

- Transport the system with care.
- Use a crane and/or a trolley for transporting the system.



⚠ WARNING

Risk of injury due to crushing.

- Install the robot coupling carefully.
- Do not place any limbs into the gaps or between the clamping pallet and the machine.

4.1 Screw tightening torques

Screw tightening torques for mounting the pallet coupling on the clamping pallet(except the screw connection for the clamping pin). (Screw quality 10.9)

Screw size	M8
Screw tightening torques M_A (Nm)	28

Screw tightening torques for mounting the robot coupling on the robot flange. Screw tightening torques for mounting the clamping pin on the pallet coupling. (Screw quality 12.9)

Screw size	M8	M16
Screw tightening torques M_A (Nm)	32	262

4.2 General installation notes

Request our installation drawings if doing the installation yourself.

If several linked clamping units are mounted, make sure that the flatness and height deviation of the locating surface from module to module (based on a gauge of 200 mm) lies within 0.01 mm.

NOTE

When connecting the robot coupling, ensure that it is only possible to completely ventilate the piston chamber via the air connections during the locking process. The relevant valves or shut-off valves should therefore be equipped with load relief. This also applies to the turbo connection. If the turbo connection is not used, the relevant side of the piston must be able to ventilate.

When disconnecting hose lines, the relevant openings must be secured with locking screws to prevent dirt or cooling lubricant from entering.

If several units are activated via shared hose lines, supply cables with the following minimum cross-sections must be used.

Number of modules	Min. hose nominal diameter
1	4 mm
2, 3, 4	6 mm
5	8 mm

4.3 Fixing and connection

Request our installation drawings if doing the installation yourself.

The NSR 160 is fixed in the installation space with 5 screws M8 (see illustration "Mounting NSR 160"). The screws must be tightened with the torque specified, ▶ 4.1 [17].

The NSR 160-84 is fixed in the installation space with 8 M8 screws and 2 Ø8 cylindrical pins (see illustration "Mounting NSR 160-84"). The screws must be tightened with the torque specified, ▶ 4.1 [17].

Two mounting screws are used as fitting screws for positioning the NSR 160 robot coupling precisely on the necessary robot flange. Precise alignment and positioning of the robot coupling requires precise positioning of the fitting bore of the Ø 10 H7 in the mounting position on the opposite side.

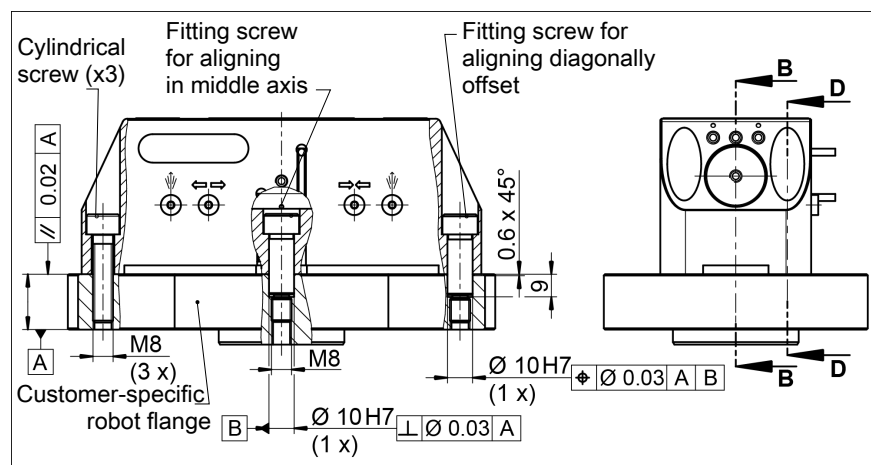

Mounting NSR 160

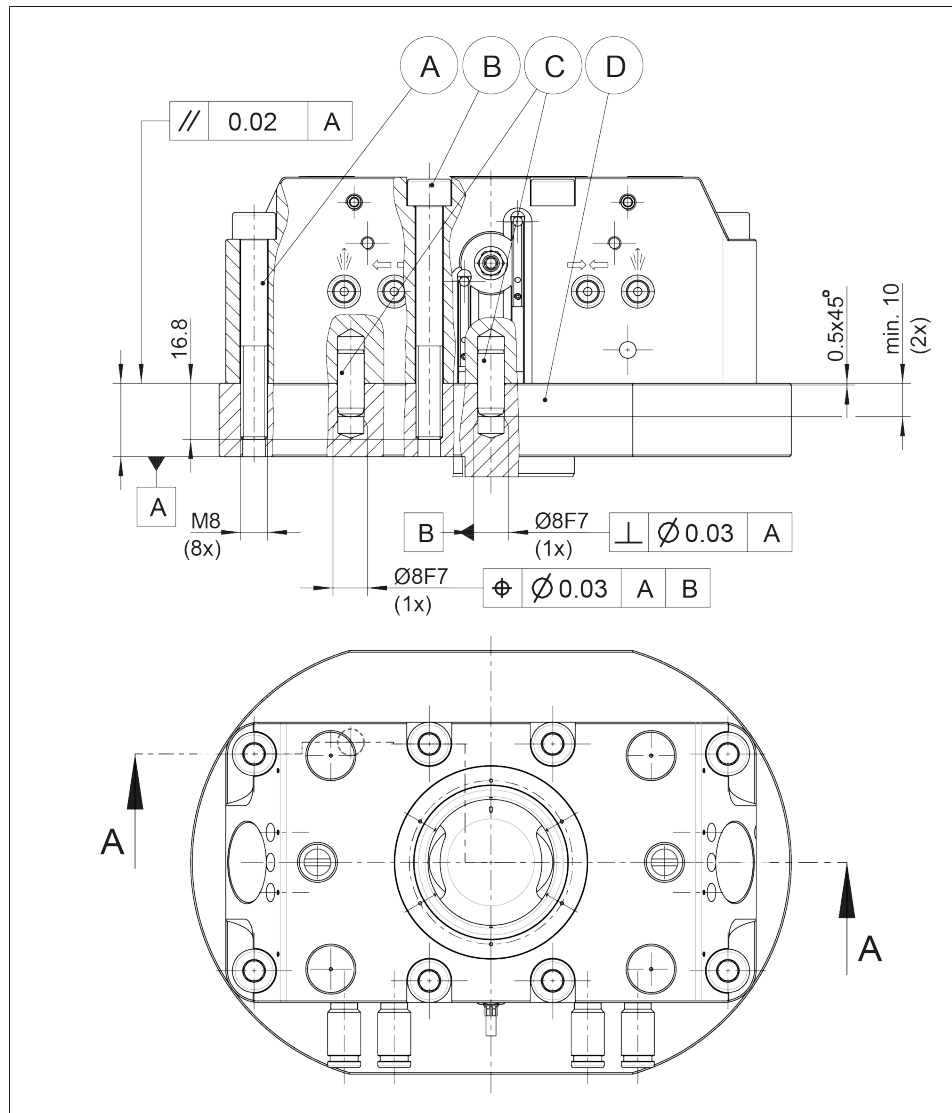

Mounting NSR 160-84

- A:** Cylindrical screw (4x)
- B:** Cylindrical screw (4x)
- C:** Cylindrical pin (2x)
- D:** Customer-specific robot flange

The air connection takes place via the M5 coupling holes at the side as standard. Any number of pneumatic screw connections can be fitted for the air supply.

There is an alternative connection option via two M3 connections in the bottom for unlocking and turbo. In this case, the side connections must be sealed off with M5 x 5 locking screws (included in scope of delivery). If this connection version is chosen, the hose-free direct connections on the base side must each be sealed with an O-ring. In the customer-specific attachment flange, recessed O-ring seats are required for this. Machine the axial sealing O-ring seat according to the following dimensions: $\varnothing 7.5^{+0.1} \times 0.7^{+0.05}$. The accessory kit for the NSR 160 contains the $\varnothing 4.5 \times 1.5$ O-rings (item 22) for sealing the bottom hose-free direct connections.

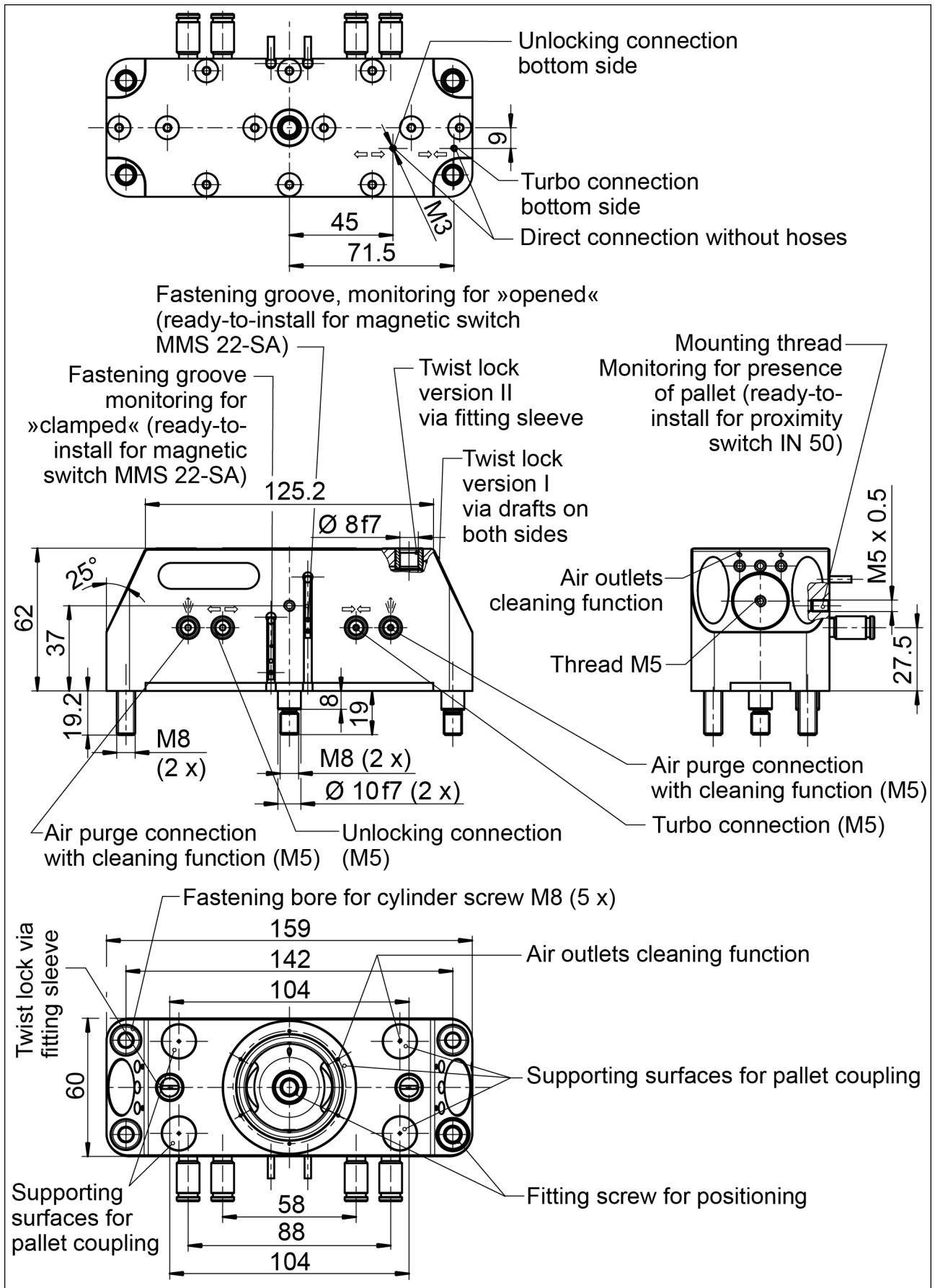

Mounting and connections NSR 160

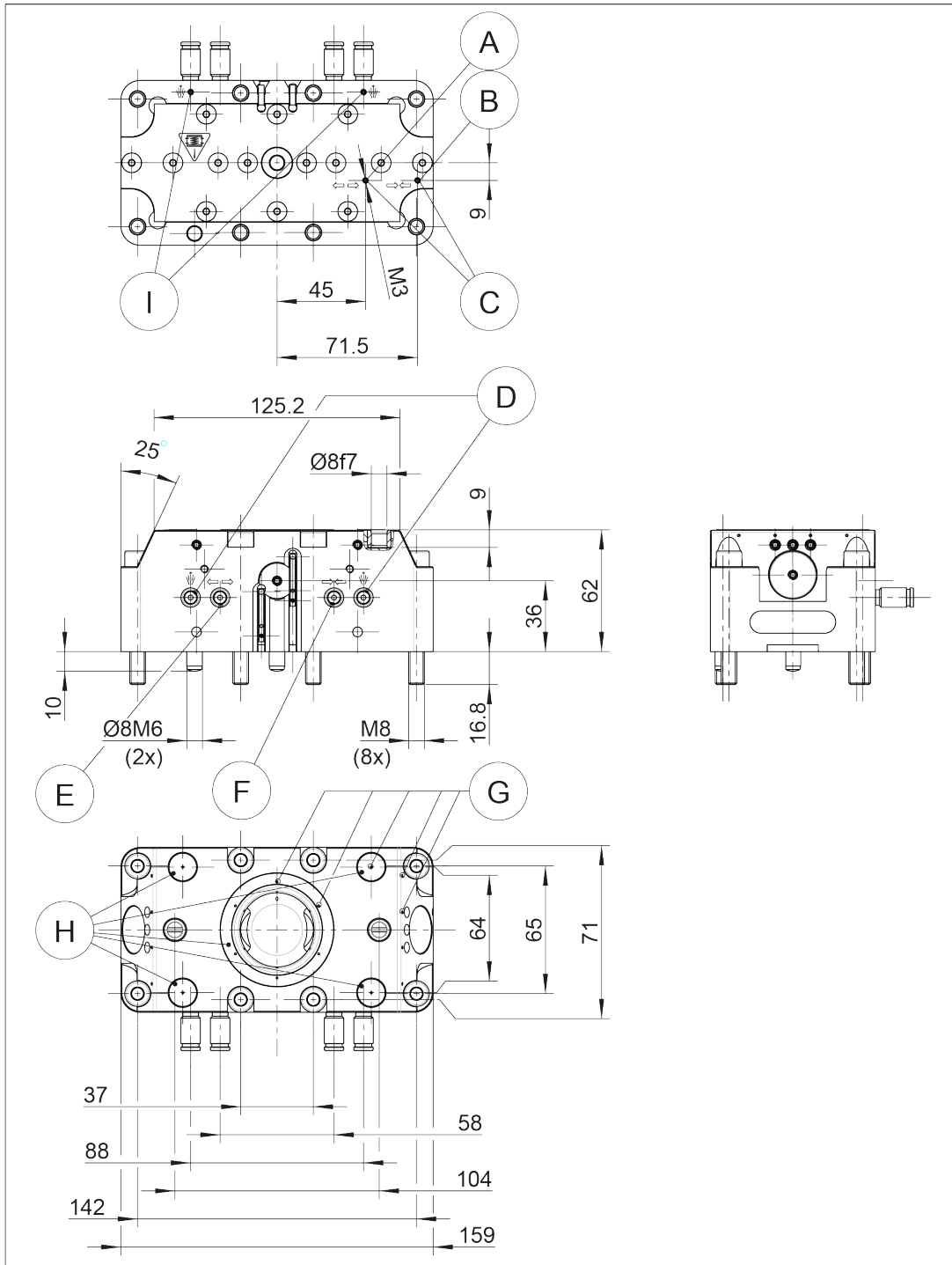

Mounting and connections NSR 160-84

A	Unlocking connection bottom side	F	Turbo connection (M5)
B	Turbo connection bottom side	G	Air outlets cleaning function
C	Hose-free direct connection	H	Supporting surfaces for pallet coupling
D	Air purge connection with cleaning function (M5)	I	Air purge connection bottom side
E	Unlocking connection (M5)		

4.3.1 Unlocking connection

If compressed air is constantly applied to the unlocking connection of the robot coupling, the clamping system is unlocked. The clamping pallet can be removed or inserted on the module for stationary use/ application via the adapted pallet coupling.

There is the option of controlling the clamping system either via the side M5 air connection hole or a hose-free direct connection in the bottom. The air connection that is not connected must be sealed air-tight with a M5 locking screw or a M3 set-screw (in the bottom), ▶ 9 [40].

4.3.2 Turbo connection

The robot coupling has a turbo connection.

When compressed air is applied, it supports the spring-actuated locking procedure actively with air pressure to increase the pull-in force even further. After a short pressure pulse via the compressed air supply, it can be switched off again – the robot coupling remains spring-loaded. In the dynamic work process, switching on the turbo function is recommended.

When the turbo connection is used, the spring-actuated locking procedure is actively supported with air pressure. If the turbo connection is not used, the relevant side of the piston must be able to ventilate.

There is the option of controlling the robot coupling either via the side M5 air connection hole or a hose-free direct connection in the bottom. The air connection that is not connected must be sealed air-tight with a M5 locking screw or a M3 set-screw (in the bottom), ▶ 9 [40].

NOTE

On a dynamically operated handling system, the robot module can only lift loads if the turbo function has been switched on before-hand.

4.3.3 Air purge connection with cleaning function

For interface cleaning, the NSR 160 and the NSR 160-84 have two side air purge connections with M5 connection thread.

The NSR 160-84 also has 2 floor-side M3 air purge connections, analogous to the connections for unlocking and turbo. Here too, the air connections on the side must be sealed with the M5 x 5 locking screws. The axial sealing O-ring seat in the customer-specific mounting flange must be provided in the same way as for the connections for turbo and unlocking.

The positively driven air flow is released on the centering and locating surfaces of the clamping system. The NSR 160 (-84) therefore has a cleaning function on all contact surfaces of the entire coupling interface.

The air supply for the air purge function is supplied via two hose lines on a connected system of channels. The use of two pressure lines increases the air outlet volume. If the air purge function is only controlled with one hose line, the open air connection must be sealed with an M5 locking screw, ▶ 9 [40].

It is advisable to use the air purge function if the clamping module approaches the pallet coupling. In doing so, the two system components to be coupled are cleaned of dirt and chips. The following must be taken into account when controlling the robot coupling NSR 160 (-84):

- Max. pressure of the air purge: 6 bar
- **The air purge must be switched off again before the pallet coupling is locked fully in the robot module, as otherwise an air cushion can form.**

4.3.4 Pneumatic circuit diagram NSR 160

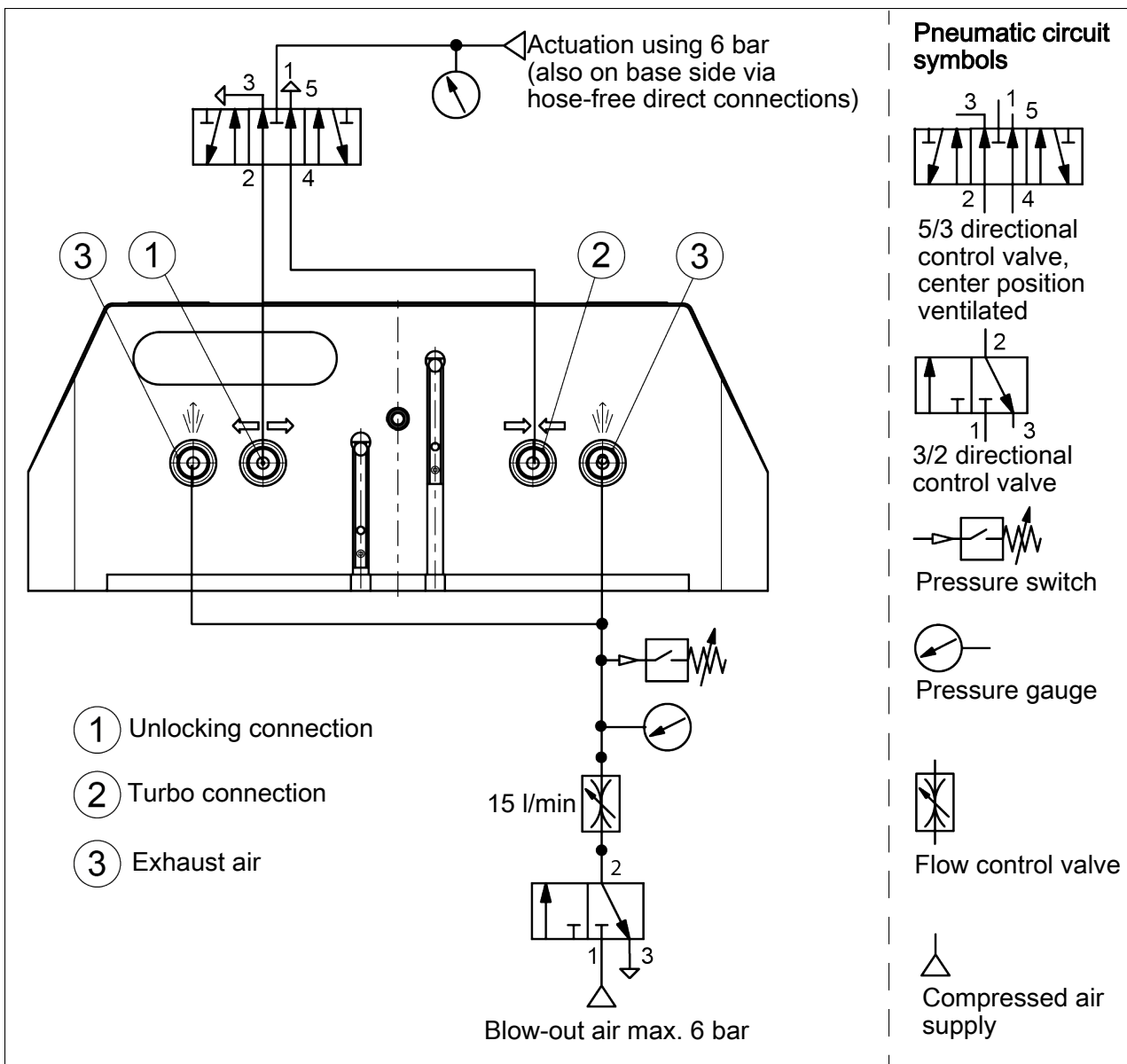

4.4 Coupling interface

The robot coupling NSR 160 has two different alignment aids for the pallet coupling.

The mounting interface for the clamping pallet is identical for the clamping pallet versions PKL-K 160 and PKL 160 (PKL 160 Lean deviating).

Torque pin variant I

Here, the pallet coupling is aligned with the robot module using the slanted contact surfaces. The wedge slants on the pallet coupling center precisely with the machining contour of the robot module during assembly (see illustration).

Note: The pallet coupling PKL(-K) 160 (Lean) can only be coupled using torque pin version I.

Torque pin variant II

The pallet coupling engages in the fitted bushings of the robot module using alignment pins during joining (see illustration).

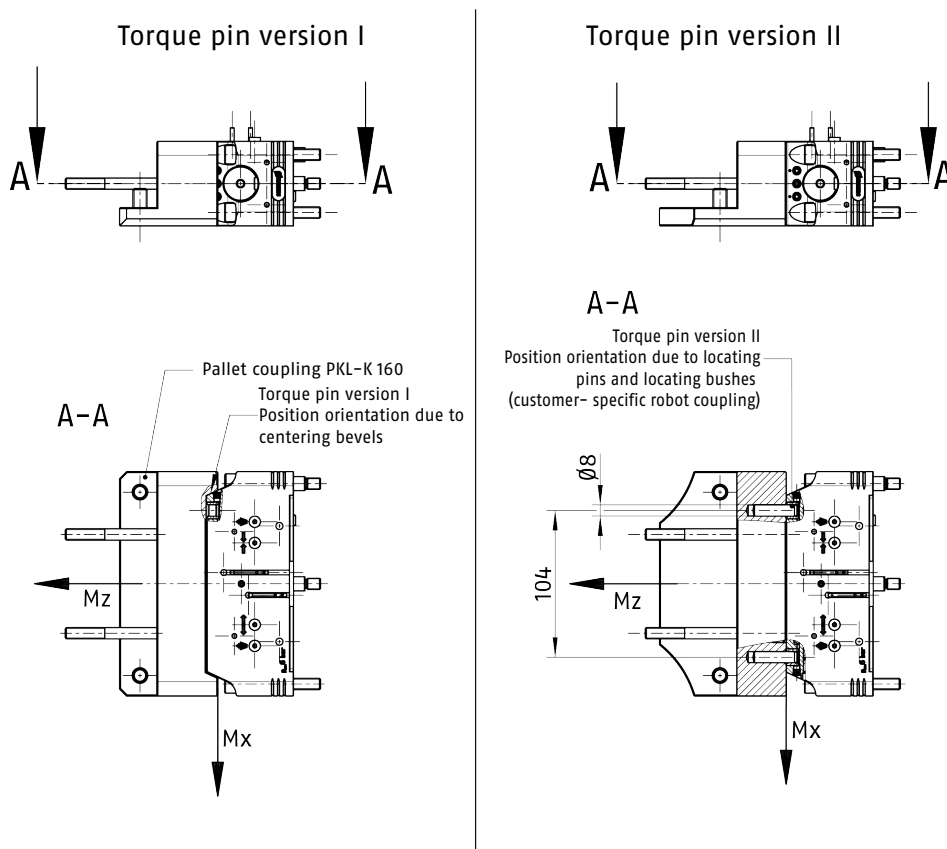

Torque pin variant I and variant II

Only an original SCHUNK clamping pin may be mounted on the coupling interface with the designated mounting screw. The screw must be tightened with the specified torque, ▶ 4.1 [17]. Replacements can be supplied by SCHUNK.

NOTE

Check the screw fitting of the clamping pin on the pallet coupling at regular intervals to ensure that it is secure. (The screws must be tightened with the specified torque, ▶ 4.1 [17]).

The pallet coupling must always guarantee a completely flat work surface at the robot coupling contact points. Design changes to the pallet coupling by the operator are only permissible with the approval of SCHUNK.

4.4.1 Pallet coupling PKL 160

The PKL-K 160 pallet coupling (ID no. 1642386) was designed as a pallet changing interface for the NSR 160 robot coupling.

Alternatively, the PKL 160 (ID no. 0471930) and the PKL 160 Lean (ID no. 40103658) can also be used in combination with the NSR 160 robot coupling.

External mold inclines are used for position orientation free from play when joining with the robot module. The pallet coupling provides the connection to the clamping pallet. The interfaces of the pallet couplings PKL-K 160 and PKL 160 have a locating surface and four mounting screws for adapting the clamping pallet.

Two long cylindrical screws act as lag screws and guarantee a high holding force and rigidity with heavy loading weights. The interface of the PKL 160 Lean pallet coupling has four lag screws and two cylindrical pins for adapting the clamping pallet. The connection interface between the clamping pallet and pallet coupling is shown in the "Connection interface between the clamping pallet and pallet coupling (PKL-K 160, PKL 160)" and "Connection interface between the clamping pallet and pallet coupling (PKL 160 Lean)" illustrations.

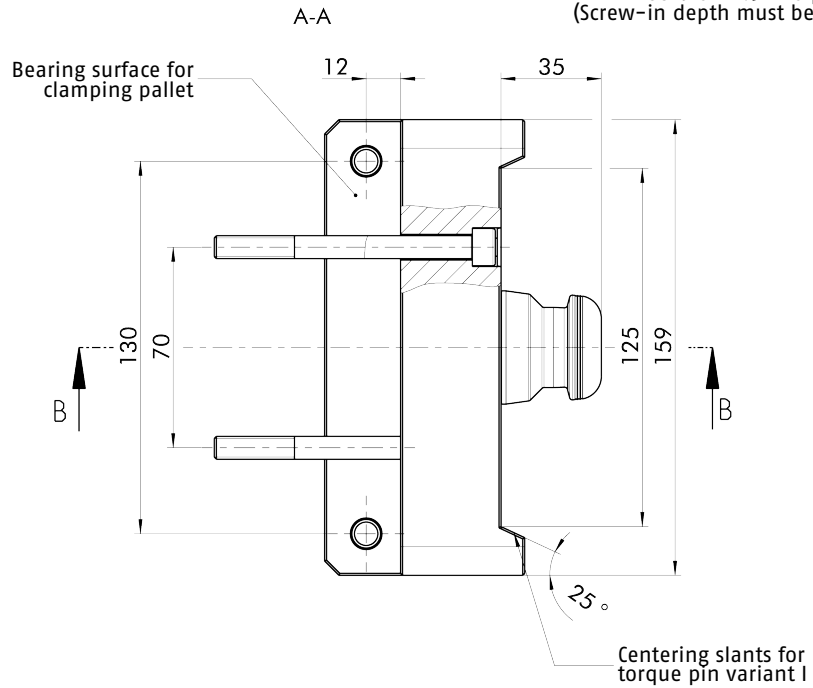
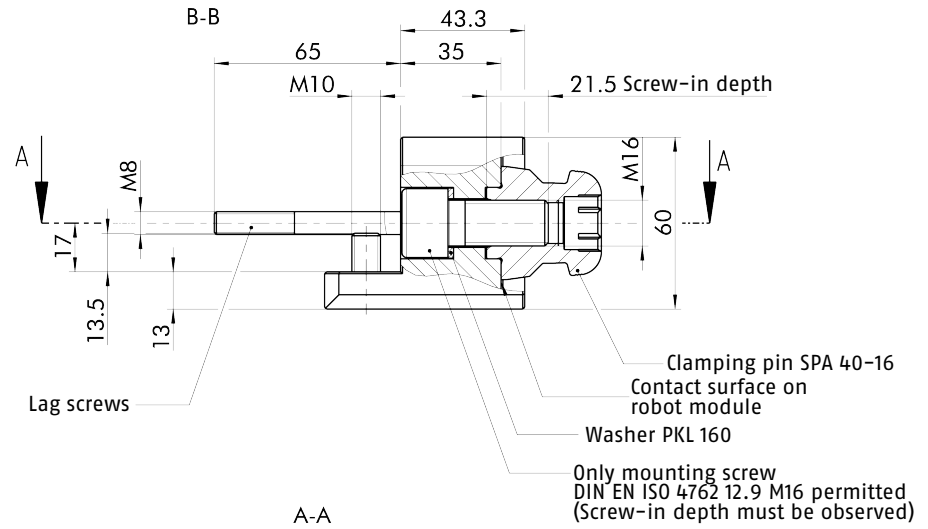

PKL-K 160 pallet coupling (PKL 160 interface identical)

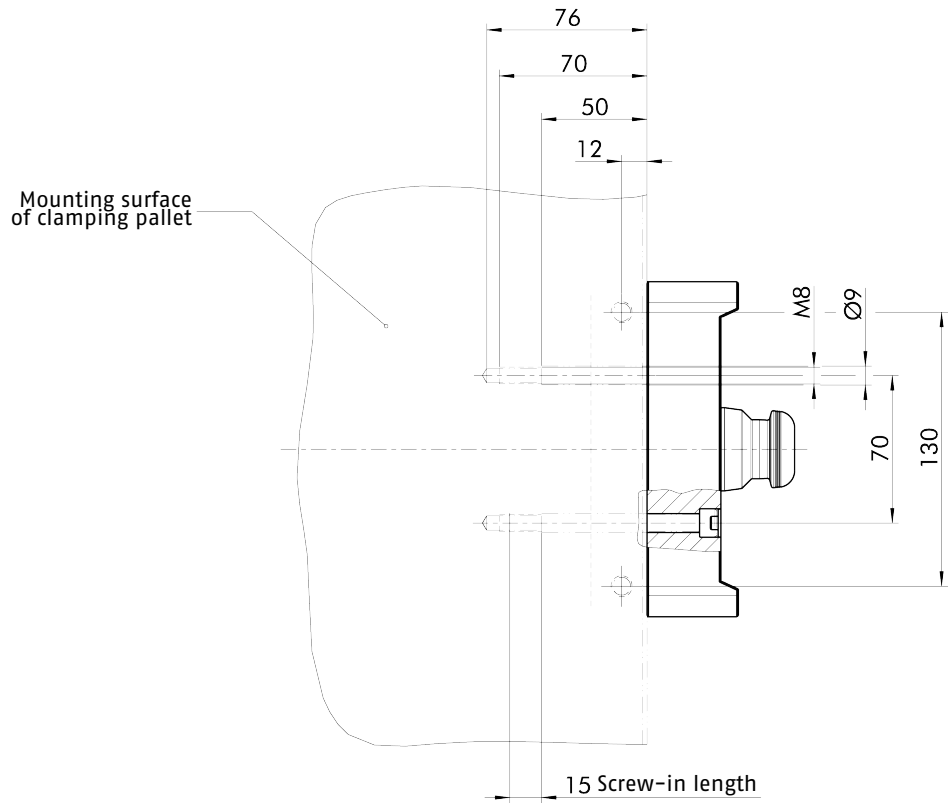
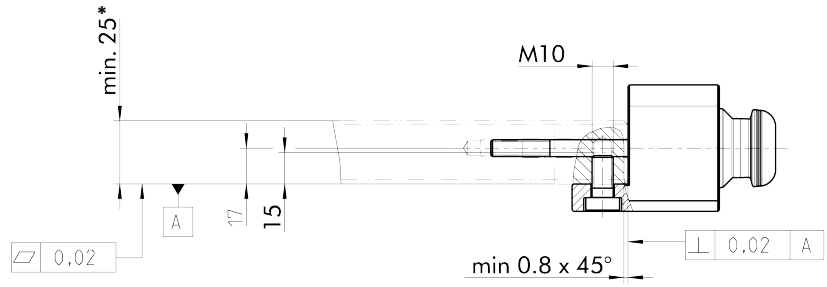

Connection interface between the clamping pallet and pallet coupling (PKL-K 160, PKL 160)

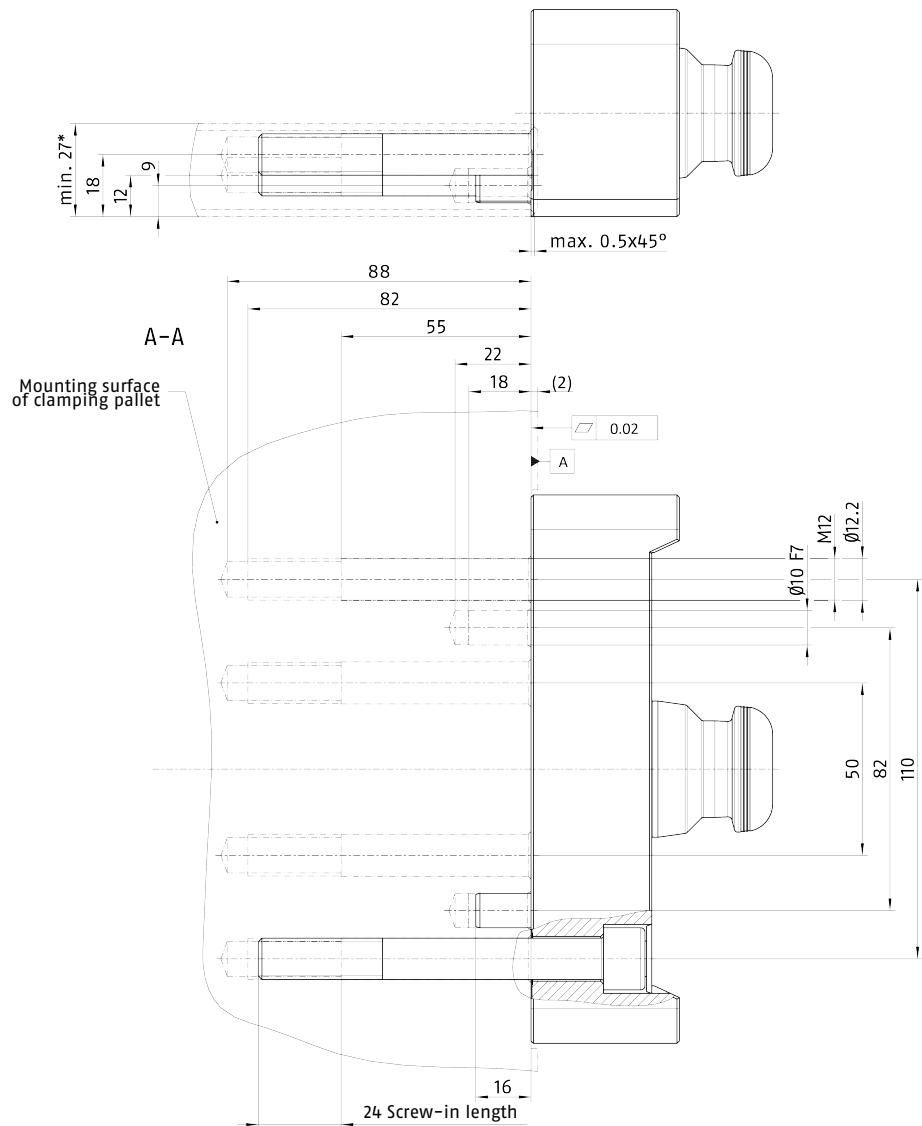

Connection interface between the clamping pallet and pallet coupling (PKL 160 Lean)

*** The height of the clamping pallet must be at least 25 mm.**

4.5 Tolerances and Installation Conditions for SPA 40-16 Clamping Pins in Customer-Specific Pallet Coupling

NOTICE

Notes on clamping pins and mounting screws

The holding force of the robot coupling is essentially limited by the tightness of the screw connection which connects the clamping pin to the pallet coupling. The clamping pin may only be installed with a size M16 screw, strength class 12.9. The specified screw torque must be observed, ▶ 4.1 [17].

- Only original SCHUNK clamping pins may be used.
- If the clamping pin is to be used in customer-specific devices, the customer must provide a sufficiently dimensioned depth of engagement in the clamping pin or a sufficiently thick mounting material in the adapter strip for the pallet coupling.

- The installation dimensions (see illustration "Tolerances and installation conditions for SPA40-16 clamping pins") are based on different adapter strip materials for the customer pallet coupling and must be observed.
- If the clamping pin is installed in an aluminum adapter strip, it is essential to install a steel washer under the screw head of the cylindrical screw DIN EN 4762 M16 12.9. The steel washer can be ordered from SCHUNK. ▶ 8.2 [39]

Installation of the clamping pin with incorrect components, e.g. excessively short mounting screw, is not permissible for pallet couplings. Replacements are available for delivery from SCHUNK.

At regular intervals, check the screw connection for the pallet coupling clamping pin for a secure fastening.

NOTE

Only the complete pallet coupling can be replaced in the robot coupling change interface. Replacing only the clamping pin would mean that the required complete flat work surface would not be achieved at the change interface.

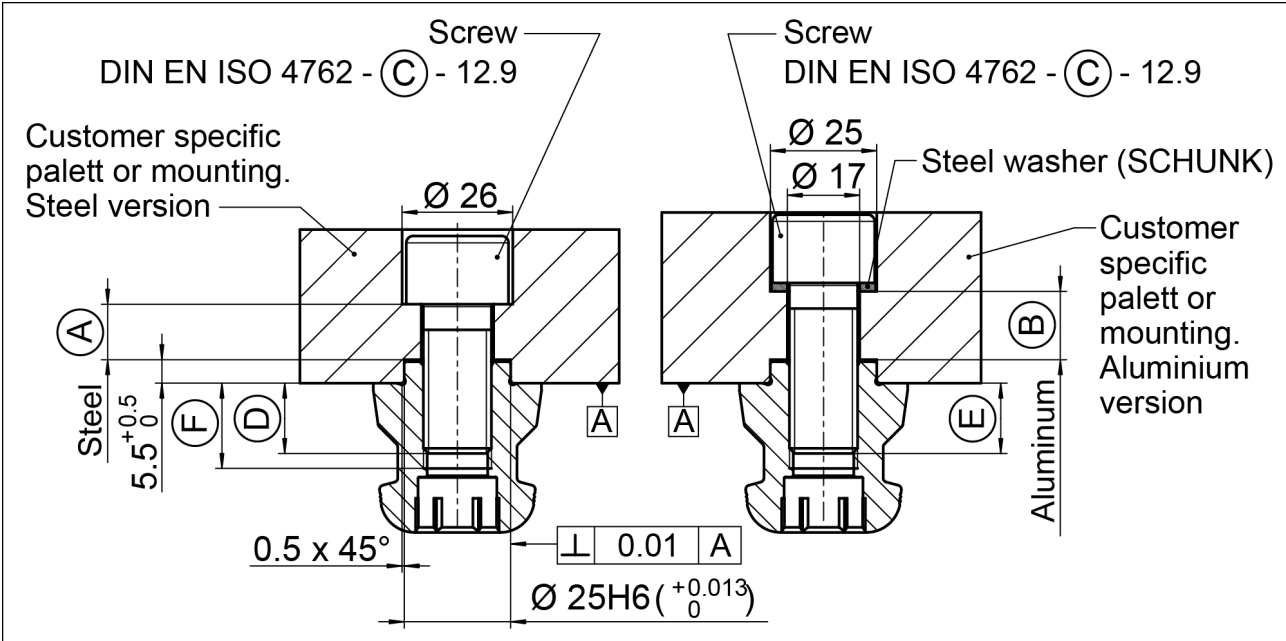

Tolerances and installation conditions for SPA40-16 clamping pins

Tolerances and installation conditions for installation in a customer-specific pallet coupling

	ID no.	A	B	C	D	E	F
SPA 40-16	0471064	> 13	> 16	M16	> 16	> 16	20

4.6 Application example for automated pallet loading

The NSR 160 clamping system was designed for automated pallet loading.

The robot coupling, with the handling system, is the interface between the machine work area and pallet rack.

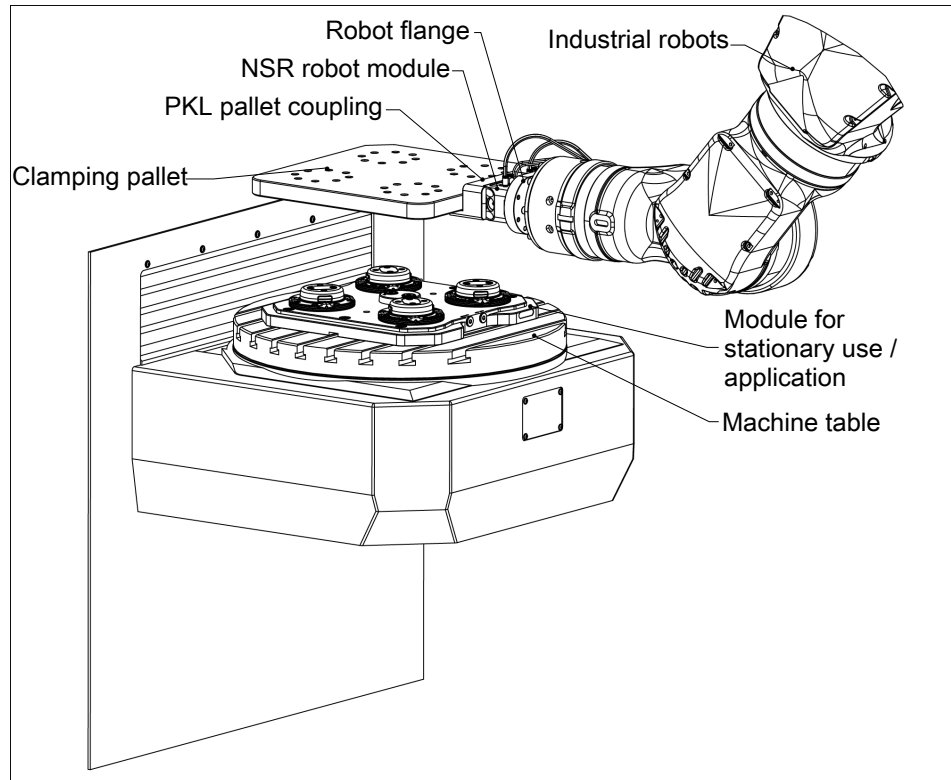

Application example for automated pallet loading

4.6.1 Connection and disconnection of transport loads

The following must be taken into account during automated connection and disconnection of transport loads:

- Approach the coupling interfaces between the robot module and pallet coupling or clamping pallet and module for stationary use / application early without a tilt angle and eccentricity (see illustration)
- Check that the traverse path is collision-free through the entire machining area.
- Work at a reduced travel speed when loading.
- Ensure a correctly aligned traverse path for connecting and disconnecting the clamping pallet (see illustration below).
- The loading handling should have overload protection.
- The operating states of the module for stationary use / application and the robot coupling must be monitored with suitable sensors to help prevent collisions and incorrect controlling.

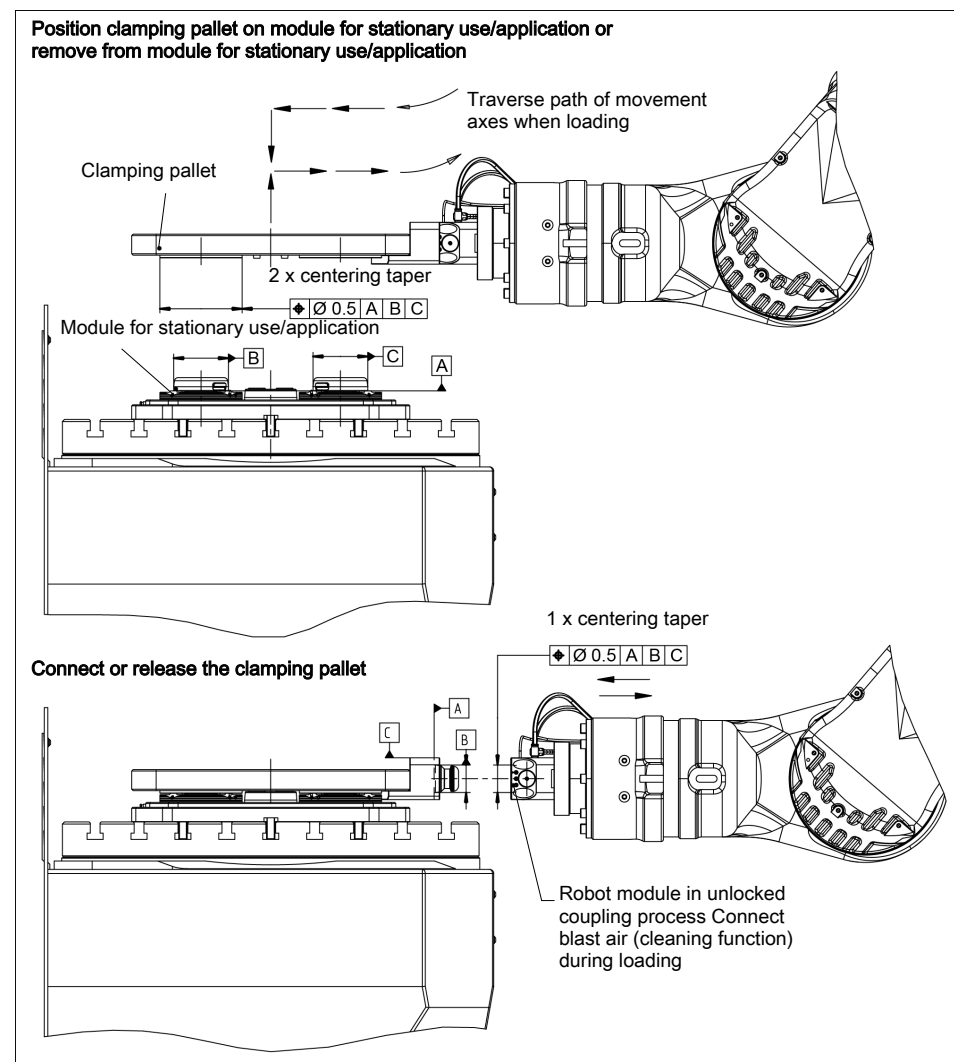

Automated connection and disconnection of transport loads

5 Maintenance and Care

The robot coupling is designed for low-maintenance operation, so that opening and disassembling is only necessary in exceptional cases.



⚠ CAUTION

Risk of injury and risk of damage to the robot coupling when opening the housing cover.

If the robot coupling has to be disassembled, send the module to SCHUNK for repair.

The cover of the robot coupling is spring preloaded and must only be removed by trained specialist personnel.

To ensure the robot coupling operates perfectly, the following instructions are to be observed:

Pressurizing medium, compressed air. Requirement for compressed air quality according to ISO 8573-1:2010 [6:4:4]

A separate maintenance unit must be used for the air supply. The robot coupling is prepared for use with unlubricated compressed air.

- Make sure that the contact surfaces of the interface are always clean.
- Make absolutely sure that no chips of any kind can enter the interface and that the interface does not fill with cooling emulsion, which is particularly possible with vertical alignment of the clamping pin axis. If the interface should fill with cooling emulsion, initiate the unlocking process and dry out the interface in actuated state.
- Only use high-quality cooling emulsions with anti-corrosive additives during processing.
- Check the robot coupling at regular intervals (at least every two weeks or after 1,000 clamping operations). The system is functioning correctly if the clamping slides move smoothly at minimum system pressure (5 bar).

5.1 Regular Inspection of Robot and Pallet Coupling

A visual inspection of the robot coupling and the associated pallet coupling for possible damage to the components must be carried out at regular intervals. This visual inspection must be carried out every 50,000 clamping cycles.

A leak test must be carried out on the robot coupling every 50,000 clamping cycles.

During a leak test, the air and plug-in connections, along with the entire clamping system, are to be tested for leaks and significant compressed air loss.

Test the robot coupling for leaks in both module positions.

To establish the tightness of the entire clamping system, no pallet coupling should be connected.

If there are leaks in the clamping system, test the entire pneumatic system (e.g. with Metaflux leak detection spray).

If any leaks are identified, check the seals and replace them if necessary. Leaks at the plug-in connections or in the pneumatic lines, for example, must be sealed and defective components replaced.

Every 100,000 clamping cycles, the screw connections between the robot coupling and the robot flange and the screw connections from the pallet coupling to the clamping pallet must be checked for secure fastening, ▶ 4.1 [17].

After a collision (e.g. when connecting or disconnecting the transport load), a visual inspection for possible damage to the components is essential. Any damage such as cracks should be identified.

If damage or signs of malfunctions are identifiable on any of the components of the robot and pallet coupling, they may not be restarted.

They can only be started up again once the faults have been remedied, for example, by replacement of the damaged unit.

6 Storage

When storing the product for a longer period of time, observe the following points:

- Clean the product and lubricate it lightly.
- Store the product in a suitable transport container.
- Only store the product in dry rooms.
- Protect the product from major temperature fluctuations.

NOTE: Before recommissioning, clean the product and all attachments, check for damage, functionality and leaks.

7 Troubleshooting

The clamping area does not unlock

Possible cause	Remedial measures
Defective air connections	Check air supply
Pressure below minimum	Check operating pressure (min. 5 bar)
A component is broken (e.g. due to overloading)	Replace the module or send it to SCHUNK for repair
Excess tensile load on clamping pins	Reduce support weight

If the clamping area does not unlock perfectly

Possible cause	Remedial measures
Pressure below minimum	Check operating pressure (min. 5 bar)
Hose diameter below minimum	for required hose diameters see ▶ 4.2 [18]
The locked connection is still pressurized	Ventilate the connection

The clamping area no longer unlocks quietly

Possible cause	Remedial measures
The clamping faces on the clamping slides and clamping pin are dirty	Remove the clamping pin and clean the clamping faces on the clamping slides and clamping pin

8 Seal kit and part lists

8.1 Sealing Kit List

Sealing kit *	ID
NSR 160	0471922
NSR 160-84	0471922

* For included items, see note **X** in the Parts List chapter below. Seals are wearing parts and are recommended to be replaced during maintenance. The sealing kit can only be ordered as a complete kit.

8.2 Part list

NSR 160 (ID 0471915)

NSR 160-84 (ID 1320140)

Item	Designation	Quantity	Note
1	Upper segment cover	1	
2	Lower segment cover	1	
3	Clamping slide	2	
4	Piston	1	
5	Piston guide	2	
14	Fitting screw	1	160 / Z
	Screw	4	160-84 / Z
15	Screw	3	160 / Z
	Screw	4	160-84 / Z
16	Fitting screw	1	160 / Z
	Cylindrical pin	2	160-84 / Z
17	Countersunk screw	12	
18	Screw	4	
19	Countersunk screw	2	X
20	O-ring	4	X
21	O-ring	4	X
22	O-ring	2	160 / V
	O-ring	4	160-84 / V
23	O-ring	2	X
24	O-ring	4	X
25	O-ring	2	X
26	Cylindrical pin	2	X
27	O-ring	2	X
28	O-ring	2	X

Item	Designation	Quantity	Note
29	O-ring	3	160 / X
	O-ring	2	160-84 / X
30	Compression spring	8	
31	Locking screw	4	160
	Locking screw	1	160-84
32	Set-screw	3	160
	Set-screw	5	160-84
33	Set-screw	1	
35	Set-screw	13	
36	Round magnet	2	
37	Straight screw-in union	4	160-84
38	Proximity switch MMS 22-SA	2	160-84
39	Screw	2	
40	Body with inlays	1	

Parts list key

160	for NSR 160	V	Wear part
160-84	for NSR 160-84	X	included in the sealing kit

PKL 160 (ID 0471930)

PKL-K 160 (ID 1642386)

PKL 160 Lean (ID 40103658)

Item	Designation	Quantity	Note
1	Strip	1	
2	Clamping pin SPA 40-16	1	
3	Screw	1	
4	Washer PKL 160	1	
5	Screw	2	160 / -K
	Screw	4	Lean
6	Screw	2	160 / -K
	Cylindrical pin	2	Lean
7	Cover plugs	2	160 / -K
	Cover plugs	4	Lean

Parts list key

160	for PKL 160
160-K	for PKL-K 160
Lean	for PKL 160 Lean

9 Assembly drawings

NSR 160

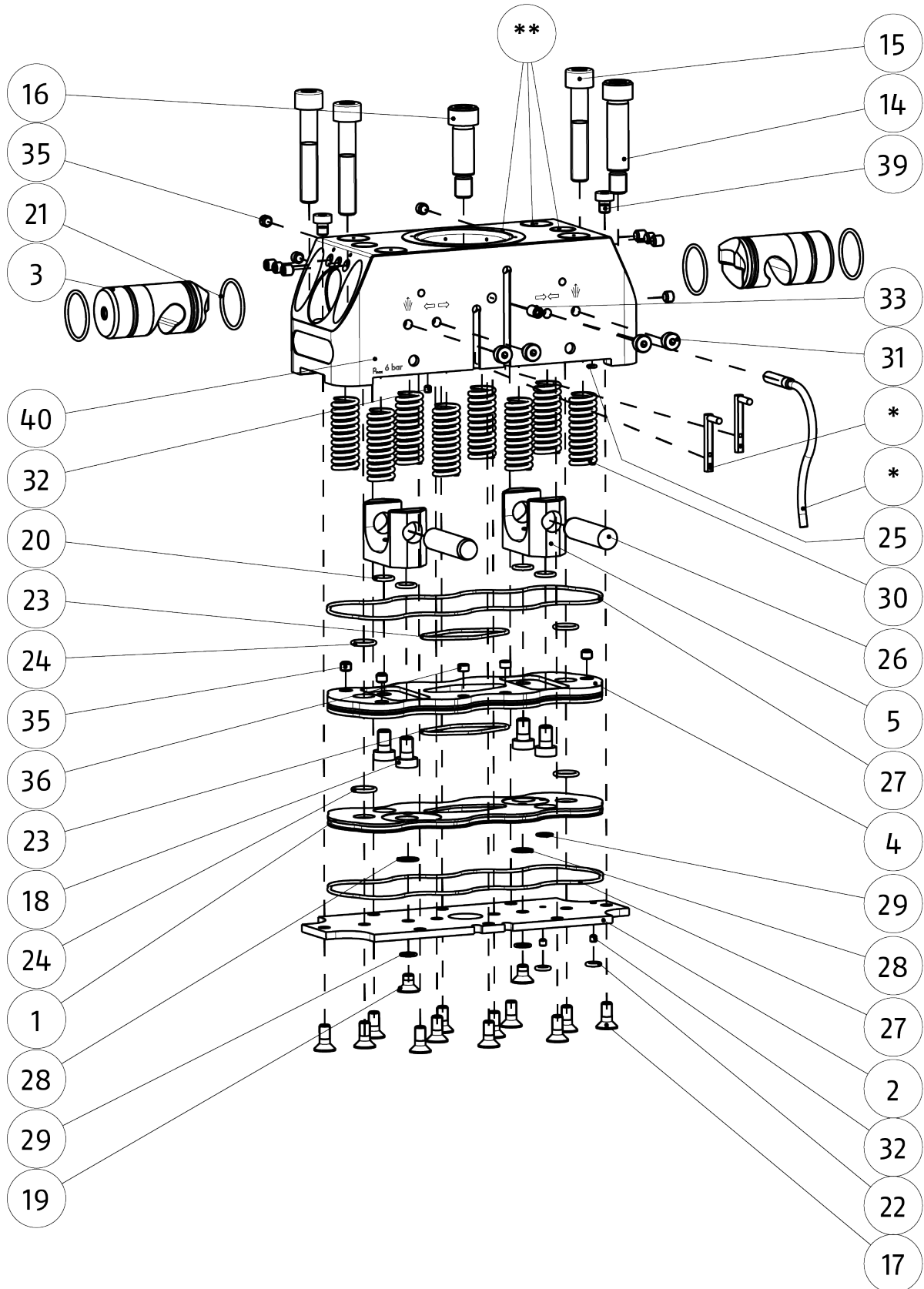

* Sensor system is available to order separately as an accessory

** Components are inseparably joined

NSR 160-84

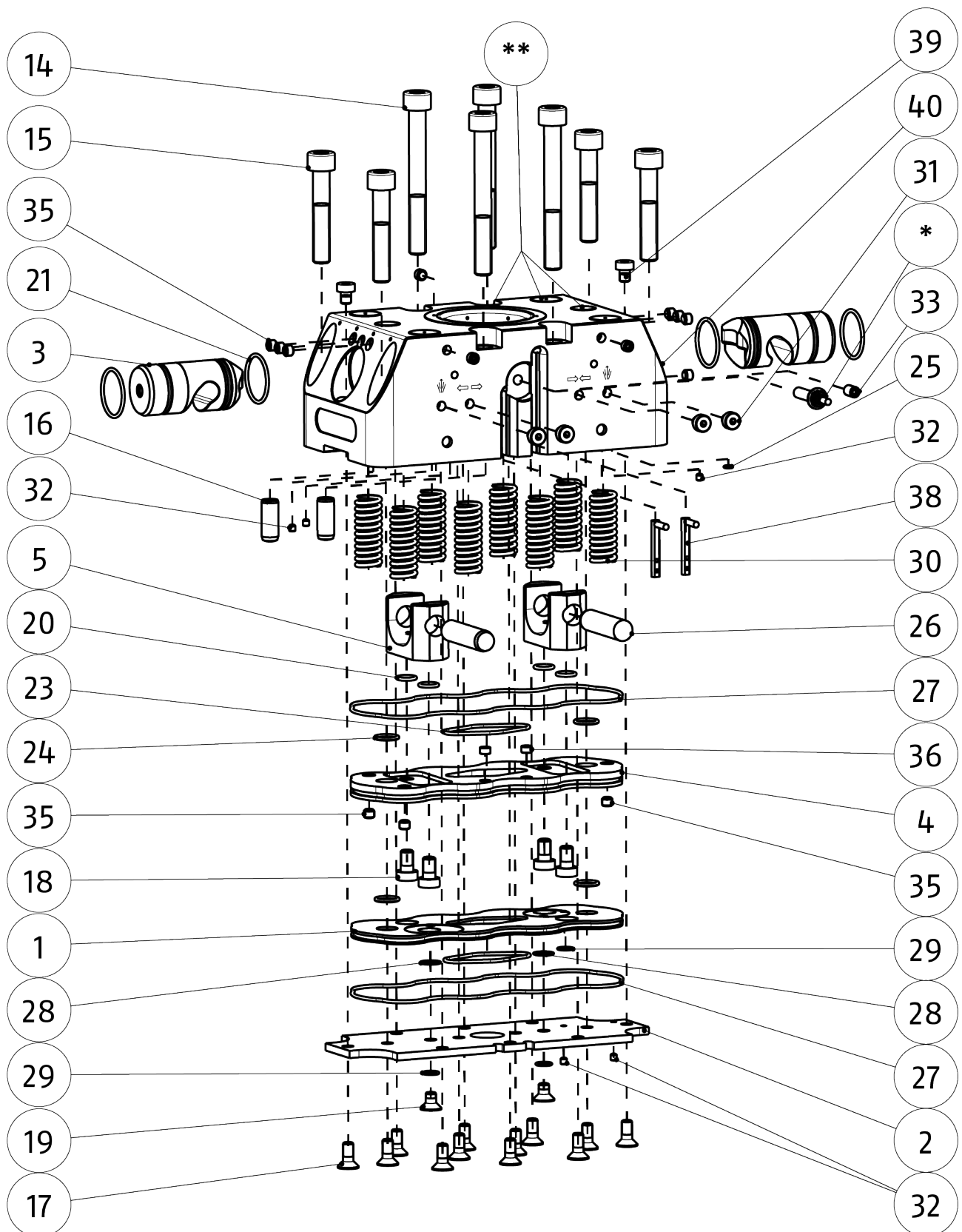

* Sensor system is available to order separately as an accessory

** Components are inseparably joined

PKL-K 160 (PKL 160 similar)

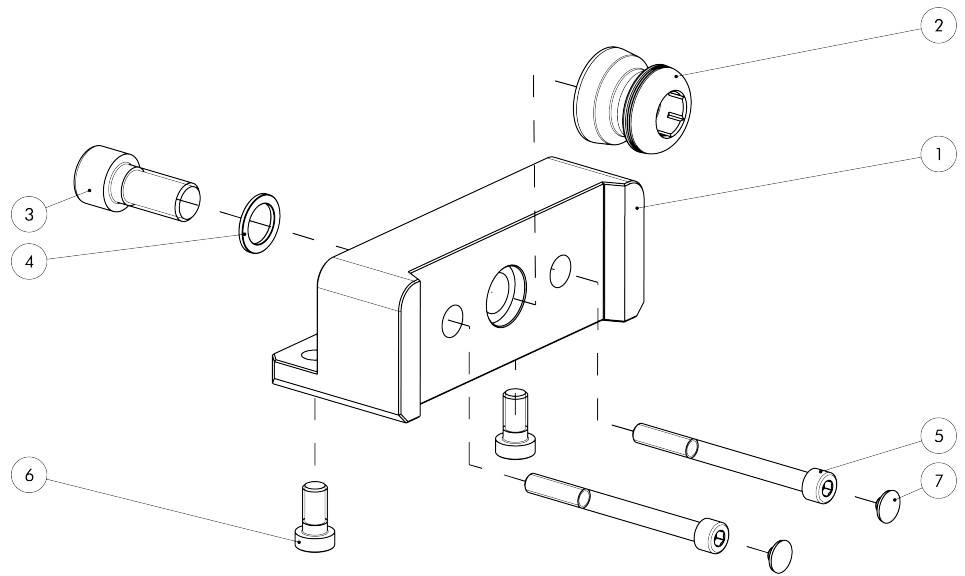

PKL 160 Lean

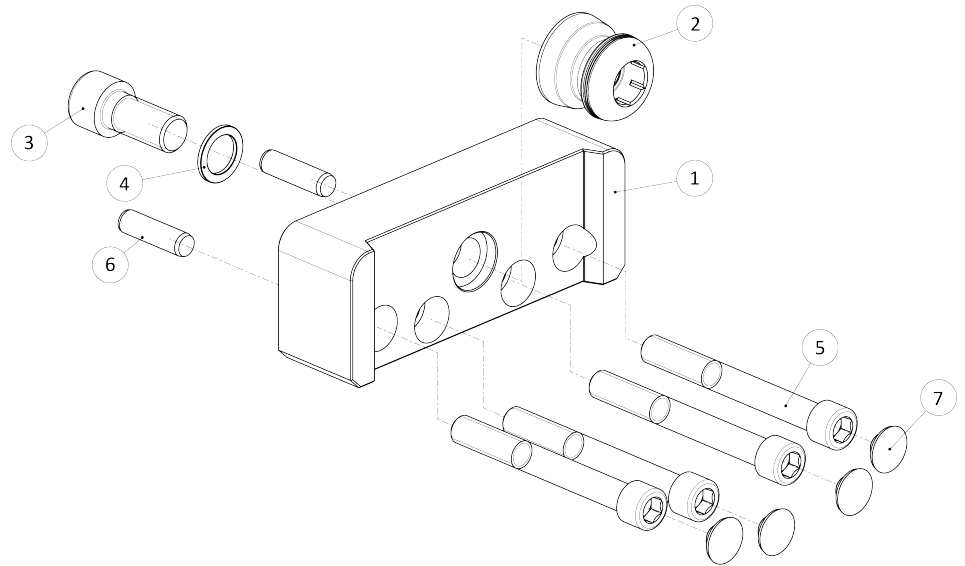

10 Sensors

The clamping systems NSR 160 and NSR 160-84 are prepared for the use of magnetic switches MMS 22-SA and the inductive proximity switch IN 50.

- Information on handling sensors is available at [schunk.com](https://www.schunk.com) or from SCHUNK contact persons.
- Technical data for the sensors can be found in the data sheets (included in the scope of delivery or available at [schunk.com](https://www.schunk.com)).

The proximity switch used has reverse polarity protection and is short-circuit-proof.

For the proper use of the proximity switches, observe the following:

- Do not pull on the cable of the sensor.
- Do not dangle the sensor from the cable.
- Do not excessively tighten the mounting screw or clips.
- Do not exceed the permissible bending radius of the cable (see catalog specifications).
- Prevent proximity switch from coming into contact with hard objects or with chemicals; in particular, nitric, chromic or sulfuric acid.

Proximity switches are electronic components which can react sensitively to high-frequency interference or electromagnetic fields.

- Check that the cable is correctly connected and installed. There must be sufficient distance between the switches and sources of interference and their supply cables.
- Parallel switching of multiple sensor outputs of the same design (nnp, pnp) is permissible, though this does not increase the permissible load current.
- Please note that the leakage current of the individual sensors is accumulative (by about 2 mA).

Assembly and setup of the MMS 22-SA

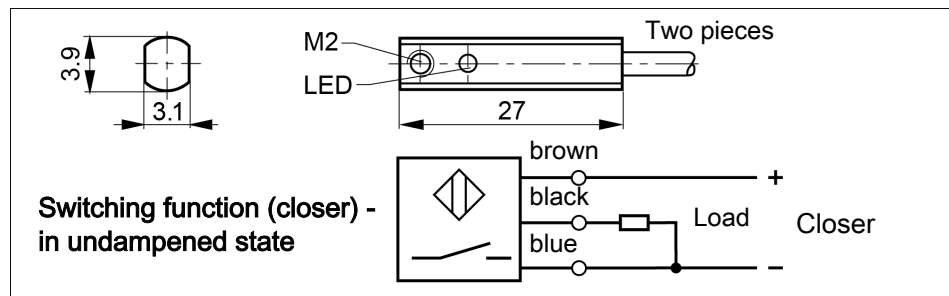

Technical data:

Voltage:	10 – 30 V DC; reverse polarity protection
Max. current on contact:	200 mA
Switching hysteresis:	0.8 mT
Temperature range:	– 10°C to + 70°C
Switching frequency approx.:	1000 Hz
Voltage drop (max. load):	1.5 V
Protection class in accordance with DIN EN 60529:	IP 67*

* for the pin terminal only when screwed on

Assembly steps for mounting the magnetic switch MMS 22-SA

Clamping system open:

- Put the clamping system in the "open" position.
- Push the magnetic switch 1 into the long groove until it touches the housing (see illustration "Assembling the proximity switch").
- Pull back the magnetic switch 1 slowly until it switches.
- Fix the magnetic switch in this position in the groove with the set-screw.
- Test the function by clamping and opening the clamping system.

clamping system clamped:

- Clamp the pallet to be clamped, position »clamped«.
- Push the magnetic switch 2 into the short groove until it touches the housing. The magnetic switch switches (see illustration "Assembling the proximity switch").
- Pull back the magnetic switch 2 slowly until it reaches the switching edge but still switches.
- Fix the magnetic switch in this position in the groove with the set-screw.
- Test the function by clamping and opening the clamping system.

NOTE

The switching point of the magnetic switch 2 may experience slight shift when clamping with or without turbo.

Assembly and setup of the IN 50

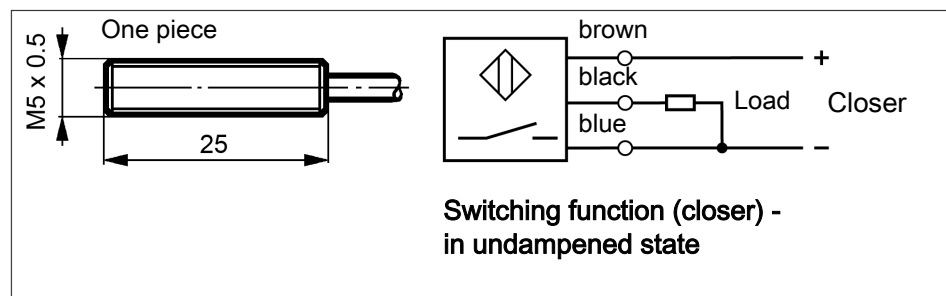

Technical data:

Voltage:	10 – 30 V DC
Ripple:	≤ 15%
Max. current on contact:	200 mA, short-circuit-proof
Switching hysteresis:	≤ 15% of the nominal switching distance
Temperature range:	–25°C to +70°C
Switching frequency approx.:	1000 Hz
Voltage drop (max. load):	1.5 V
Protection class in accordance with DIN EN 60529:	IP 67*

* for the pin terminal only when screwed on

The inductive proximity switch IN 50 can be used to monitor the presence of a pallet in the clamping system (see illustration "Assembling the proximity switch").

For this, remove the set-screw (Pos. 33) on the clamping system and screw in the proximity switch. Set the switching point so that the proximity switch switches when the pallet is present. Secure the IN 50 with the counter nut and test the function.

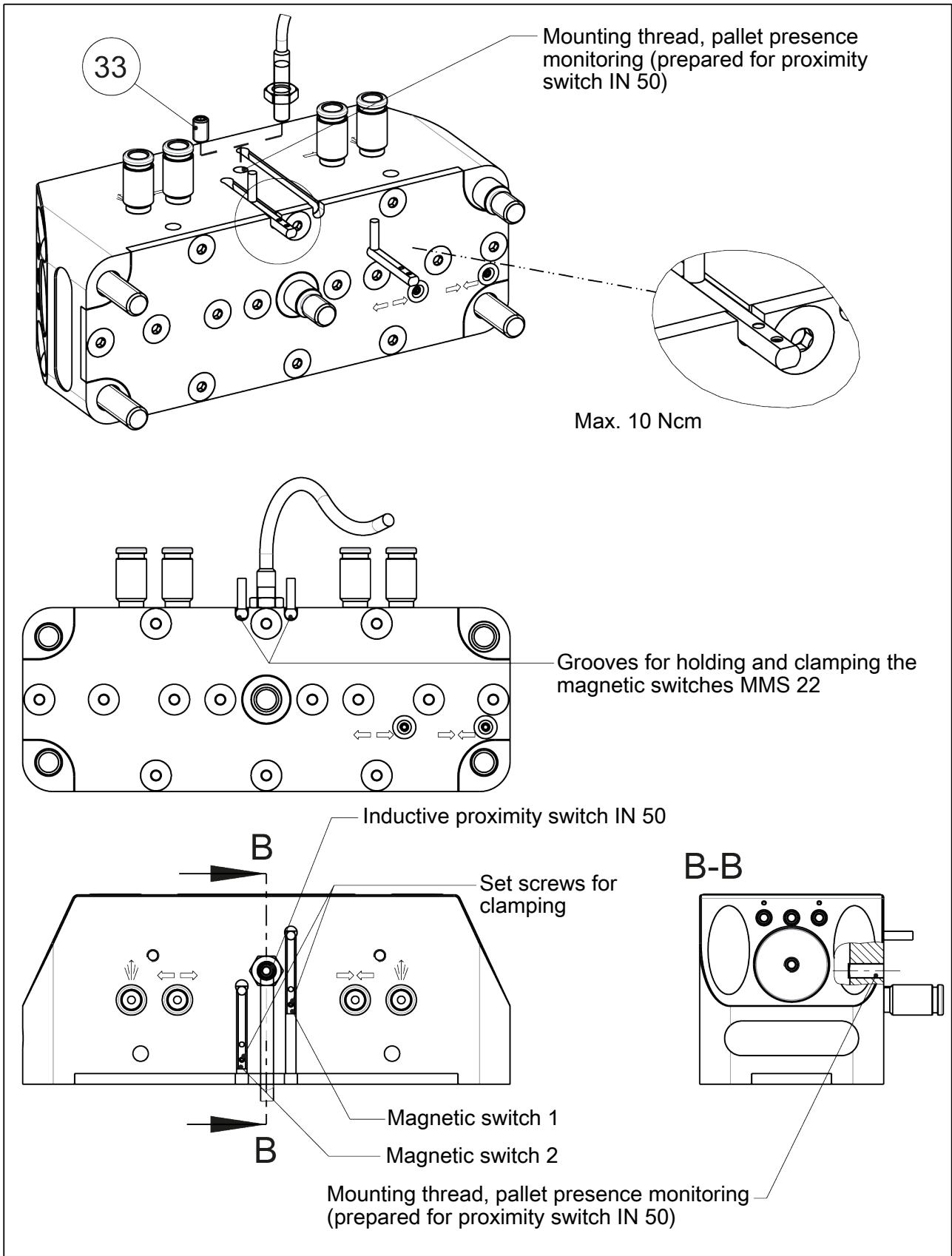

Mounting the proximity switches on the NSR 160

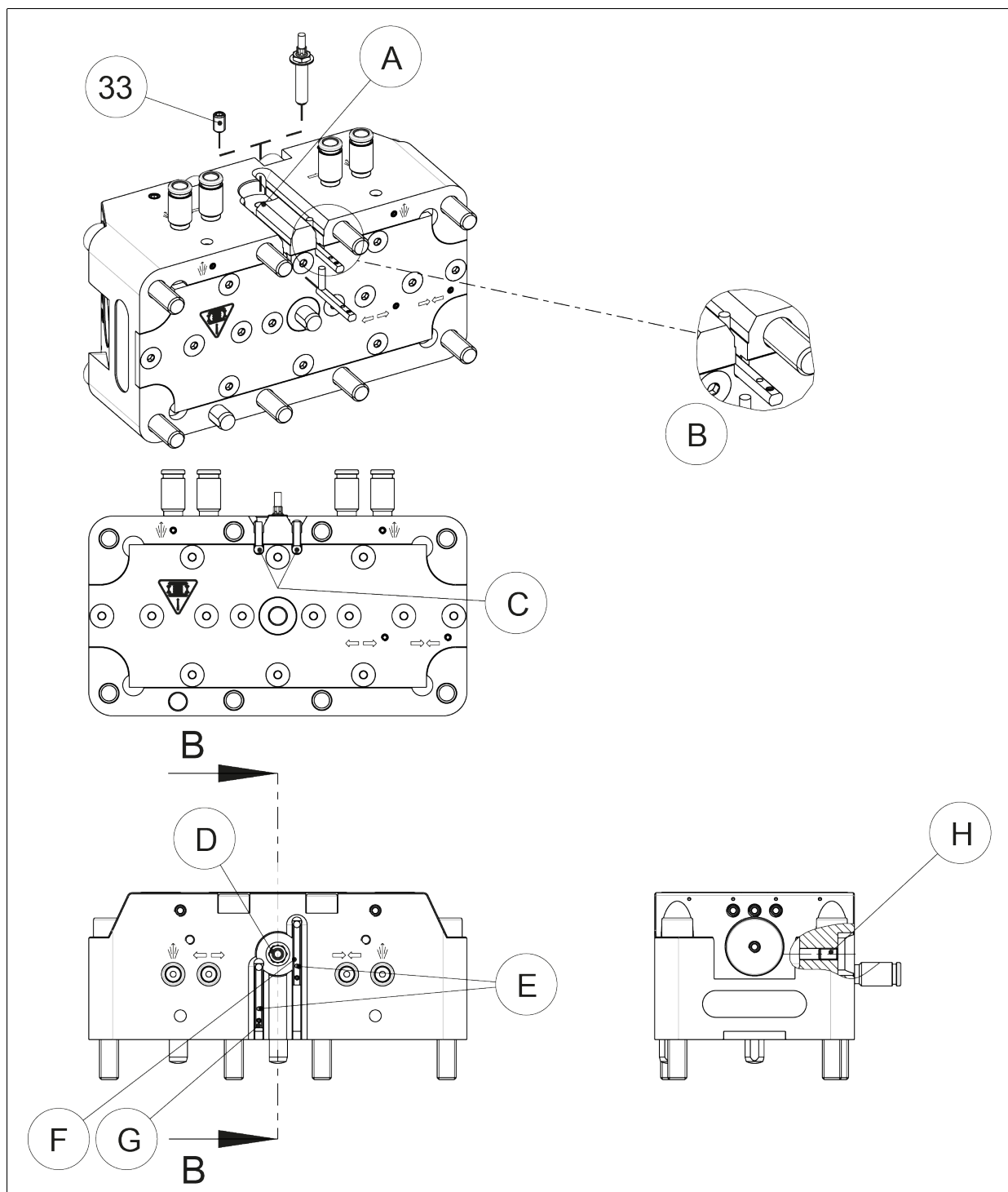

Mounting the proximity switches on the NSR 160-84

33	set-screw	E	Set screws for clamping
A	Mounting thread, pallet presence monitoring (prepared for proximity switch IN 50)	F	Magnetic switch 1
B	Max. 10 Ncm	G	Magnetic switch 2
C	Grooves for holding and clamping the magnetic switches MMS 22	H	Mounting thread, pallet presence monitoring (prepared for proximity switch IN 50)
D	Inductive proximity switch IN 50		

11 Manufacturer certificate

Manufacturer / Distributor:	H.-D. SCHUNK GmbH & Co. Spanntechnik KG Lothringer Str. 23 D-88512 Mengen
Product:	Quick-change pallet system
Designation:	VERO-S
Type designation:	NSR

Heinz-Dieter SCHUNK GmbH & Co. Spanntechnik KG certifies that the above-mentioned products, when used as intended and in compliance with the operating manual and the warnings on the product, are safe according to the national regulations and:

- a **risk assessment** has been carried out in accordance with ISO 12100:2010.
- an **operating manual** for the assembly instructions has been created in accordance with the contents of the Machinery Directive 2006/42/EC Annex I No. 1.7.4.2. and the contents of the provisions of Annex VI of the Machinery Directive 2006/42/EC.
- **Markings** have been made in accordance with EN 1550:1997+A1:2008 Section 6.3.1, VDMA 34192:2019 Section 6.3 or ISO 16156:2004 Section 6.3. The requirements of Annex I No. 1.7.3. of the Machinery Directive 2006/42/EC have been complied with.
- the relevant basic and proven safety principles of the Annexes of **ISO 13849-2:2012**, taking into account the requirements of the documentation have been observed for the component. The parameters, limitations, ambient conditions, characteristic values, etc. for proper operation are defined in the operating manual.
- an $MTTF_0$ value of 150 years can be estimated for mechanical components using the informative procedure in Table C.1 of ISO 13849-1:2015.
- **fault exclusion** against the fault "Unexpected release without pending release signal".
- the **fault exclusion** against the fault "Breakage during operation" in compliance with the parameters, limitations, ambient conditions, characteristic values and maintenance intervals, etc., specified in the operating manual.
- that internal bore diameters in the **pipe or control lines** are at least 2 mm for pneumatic clamping systems and at least 3 mm for hydraulic clamping systems

Harmonized Standards applied:

- **ISO 12100:2010** Safety of machinery – General principles for design – Risk assessment and risk reduction

Other related technical Standards and specifications:

- **VDMA 34192:2019** Safety requirements for clamping devices for use on machines

Mengen, 25th of April 2023

Signature: see original declaration

Signature: see original declaration

p.p. Philipp Schröder
Head of Development standard products

p.p. Alexander Koch
Head of Engineering Design special products

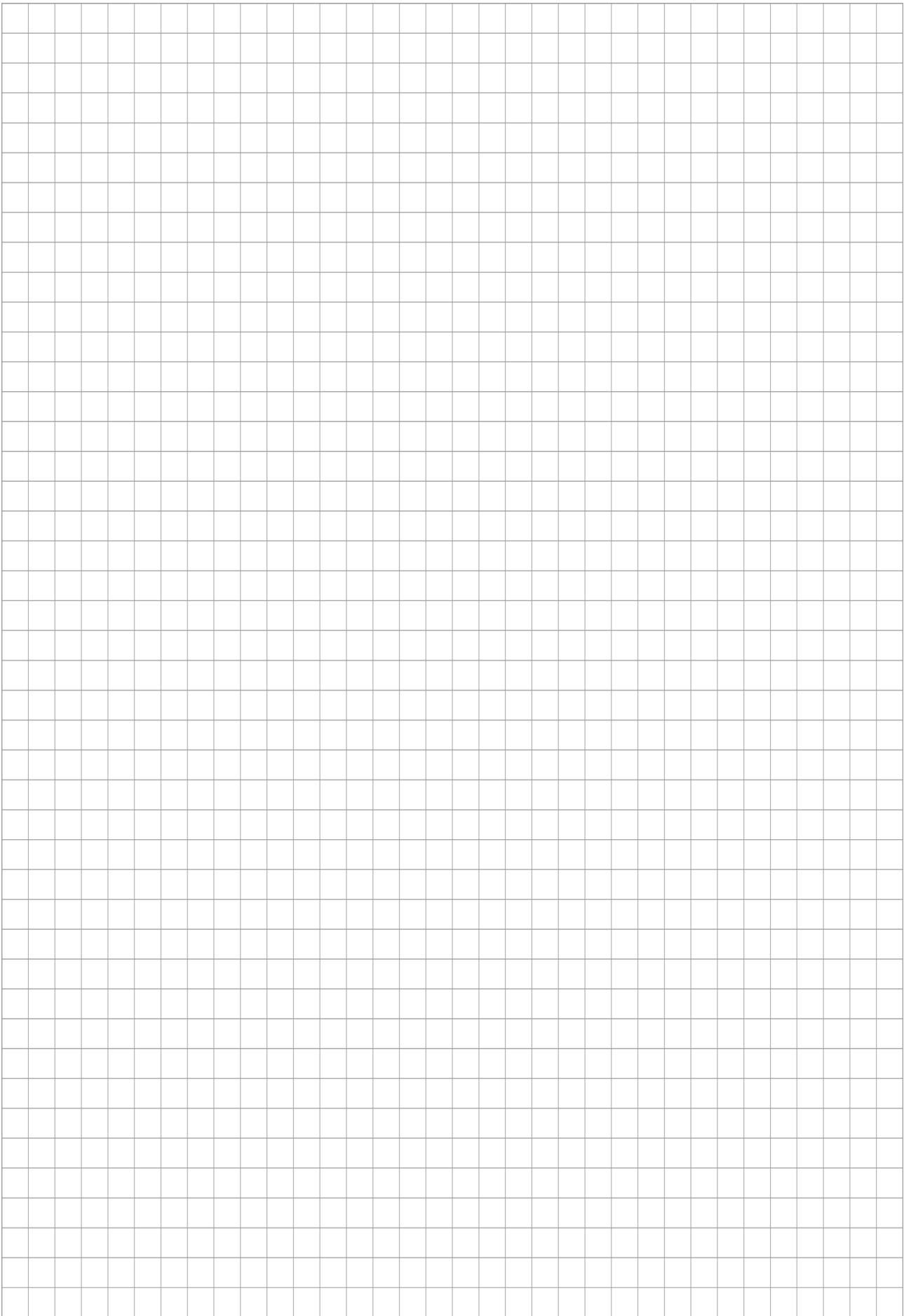

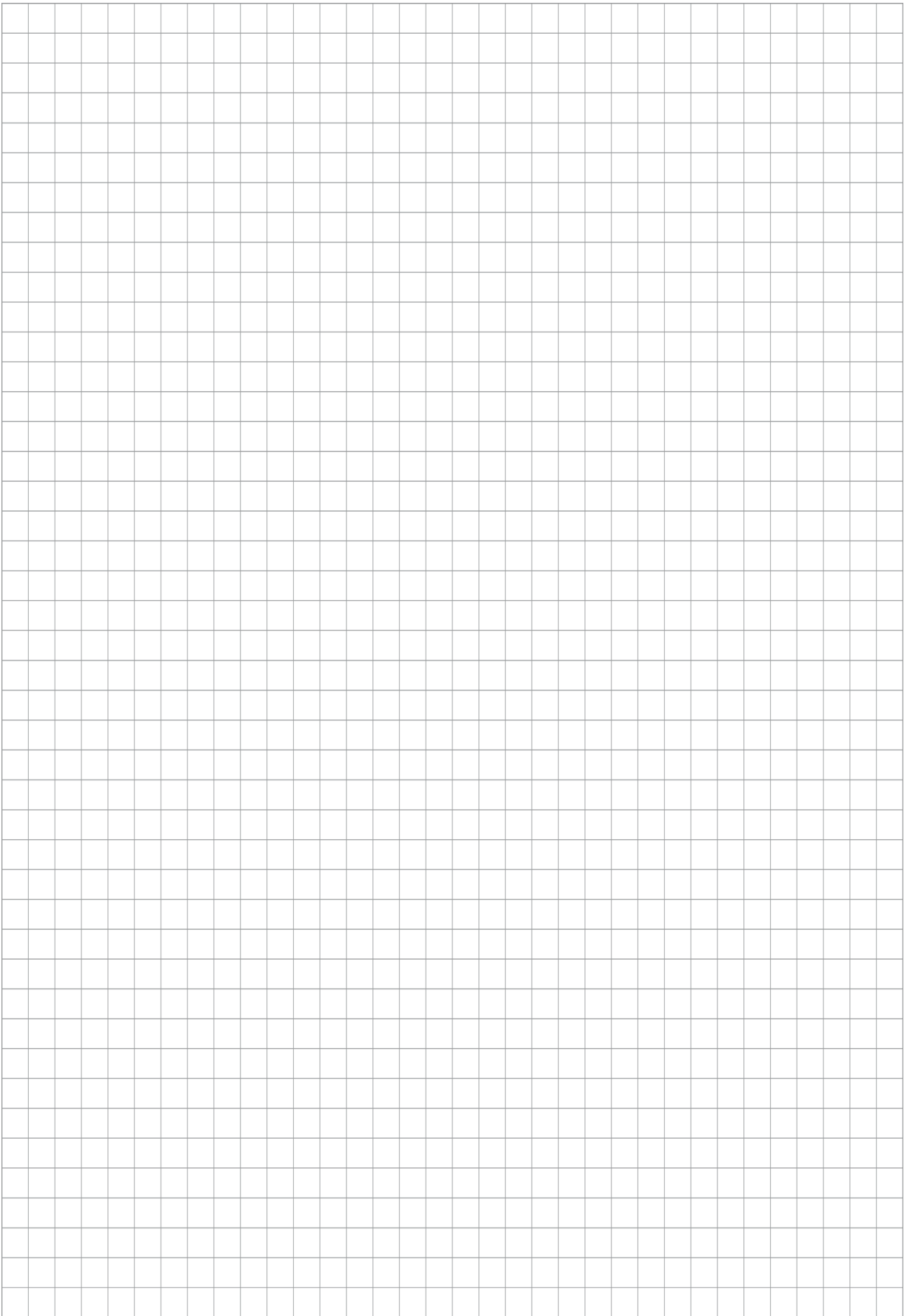





H.-D. SCHUNK GmbH & Co.
Spanntechnik KG

Lothringer Str. 23
D-88512 Mengen
Tel. +49-7572-7614-0
info@de.schunk.com
schunk.com

Folgen Sie uns | *Follow us*



Wir drucken nachhaltig | *We print sustainable*