



Assembly and Operating Manual

TENDO SK 50

Tool grinding toolholder

Translation of Original Operating
Manual

Imprint

Copyright:

This manual is protected by copyright. The author is SCHUNK SE & Co. KG.
All rights reserved.

Technical changes:

We reserve the right to make alterations for the purpose of technical improvement.

Document number: 0289007

Version: 04.00 | 08/01/2026 | en

Dear Customer,

Thank you for trusting our products and our family-owned company, the leading technology supplier of robots and production machines.

Our team is always available to answer any questions on this product and other solutions. Ask us questions and challenge us. We will find a solution!

Best regards,

Your SCHUNK team

Customer Management

Tel. +49-7133-103-2500

Fax +49-7133-103-2239

cms@de.schunk.com



Please read the operating manual in full and keep it close to the product.

Table of Contents

1 General	5
1.1 About this manual.....	5
1.1.1 Presentation of Warning Labels	5
1.1.2 Definition of Terms	6
1.1.3 Symbol definition.....	6
1.1.4 Applicable documents	6
1.2 Warranty	6
1.3 Scope of delivery.....	7
1.4 Accessories	7
2 Basic safety notes	8
2.1 Intended use.....	8
2.2 Not intended use	8
2.3 Notes on safe operation.....	9
2.4 Personnel qualifications	10
2.5 Personal protective equipment	11
2.6 Handling during transport	11
2.7 Structural changes.....	12
2.8 Behavior in case of malfunctions.....	12
2.9 Hazardous points on the product.....	13
3 Technical data	14
3.1 Product data	14
3.2 Ambient conditions and operating conditions	15
4 Design and description	16
4.1 Design	16
4.2 Description of function	17
5 Assembly	18
5.1 Basic information.....	18
5.2 Assembly of the product	19
6 Settings and functional testing	20
6.1 Basic information.....	20
6.2 Checking the expansion rate.....	21
6.3 Checking the clamping function	21

7 Operation	22
7.1 Basic information	22
7.2 Clamping the workpiece	24
7.3 Unclamping the workpiece	24
7.4 Using the intermediate sleeve	25
7.4.1 Assembly/disassembly of the intermediate sleeve	26
8 Maintenance	28
8.1 Basic information	28
8.2 Intervals and tasks	29
8.2.1 Clean the clamping surface and workpiece stop face	30
8.2.2 Cleaning the product	30
8.2.3 Cleaning the pressurized air hole	30
8.2.4 Check the expansion rate	31
8.2.5 Check and lubricate the clamping screw	32
8.2.6 Polish the clamping surface	34
8.2.7 Disassembly/changing of the intermediate sleeve	38
9 Troubleshooting	39
10 Disassembly	40
10.1 Basic information	40
10.2 Disassembly of the product	40
11 Storage	41
12 Disposal	42
13 Drawings	43

1 General

1.1 About this manual

This manual contains important information for a safe and appropriate use of the product.

This manual is an integral part of the product and must be kept accessible for the personnel at all times.

Before starting work, the personnel must have read and understood this operating manual. Prerequisite for safe working is the observance of all safety instructions in this manual.

In addition to these instructions, the documents listed under ▶ 1.1.4 [6] are applicable.

NOTE: The illustrations in this manual are intended to provide a basic understanding and may deviate from the actual version.

1.1.1 Presentation of Warning Labels

To make risks clear, the following signal words and symbols are used for safety notes.



⚠ DANGER

Dangers for persons!

Non-observance will inevitably cause irreversible injury or death.



⚠ WARNING

Dangers for persons!

Non-observance can lead to irreversible injury and even death.



⚠ CAUTION

Dangers for persons!

Non-observance can cause minor injuries.

NOTICE

Material damage!

Information about avoiding material damage.

1.1.2 Definition of Terms

The term "product" replaces the product name on the title page in this manual.

1.1.3 Symbol definition

The following symbols are used in this manual:

■ Prerequisite for an action

1. Action 1

2. Action 2

⇒ Intermediate results

⇒ Final results

▶ 1.1.3 [6]: chapter number and [page number] in hyperlinks

1.1.4 Applicable documents

- General terms of business *
- Contractual agreements

The documents labeled with an asterisk (*) can be downloaded from [schunk.com/downloads](https://www.schunk.com/downloads).

1.2 Warranty

If the product is used as intended, the warranty is valid for 12 months from the date of delivery from the production facility or 50 000 cycles* under the following conditions:

- Observe the applicable documents, ▶ 1.1.4 [6]
- Observe the ambient conditions and operating conditions, ▶ 3.2 [15]
- Observe the specified maintenance instructions, ▶ 8 [28]

This does not include special agreements detailed in the warranty and wearing parts. Wearing parts can also become worn through appropriate use before the maximum number of clamping cycles has expired. This includes all areas which come into contact with the workpiece or the machine (clamping area and mount) and sealing elements.

* One cycle comprises one complete clamping procedure ("clamping" and "unclamping").

1.3 Scope of delivery

The scope of delivery includes

- 1 **Hydraulic expansion toolholder** in the ordered variant (ID 0219220; 0219221; 0219222; 0219223; 0219224; 0219225; 0219226; 0219227; 0219228; 0219229)
- 1 **Assembly and Operating Manual** (ID 0289007)

1.4 Accessories

The following accessories for the product are available separately:

Intermediate sleeve without lock GZB-S PK
not coolant-proof

Intermediate sleeve without lock GZB-S KD
coolant-proof

Sleeve remover (ID 9937987)

Clamping screw (ID 7002019)

Dirt cover with seal (ID 7002041)

Safety ring (ID 9948485)

Actuation key (ID 9205640)

Length-setting screw (see table)

ID Product	ID Length-setting screw	Thread
0219221	7000427	M5
0219222	7000429	M6
0219223	7000430	M8x1
0219224	7000430	M8x1
0219229	7000431	M10x1
0219225	7000432	M12x1
0219220	7000432	M12x1
0219226	7000433	M16x1
0219227	7000433	M16x1
0219228	7000433	M16x1

2 Basic safety notes

2.1 Intended use

- The product is intended for picking up, clamping and reliably holding fully cylindrical workpieces (the tools to be ground are workpieces in this case).
- The product is used for tool grinding.
- The product is intended for industrial use.
- The product may only be used and applied within the scope of the information in the technical data, ▶ 3 [14].
- The product is intended for installation in a machine/ automated system. The applicable guidelines for the machine/ automated system must be observed and complied with.
- Appropriate use of the product includes compliance with all instructions in this manual.

2.2 Not intended use

The product is not being used as intended if, for example:

- Tools or similar are picked up and clamped in order to machine workpieces.
- The product is used for something other than tool grinding.
- The information in the technical data is not observed when using and operating the product ▶ 3 [14].
- The product is used as a lifting tool.
- The minimum clamping depth is not observed (clamping length is not completely covered).
- The expansion rate control system is not observed ▶ 8.2.4 [31].
- The product is used in corrosive media.
- The maintenance and storage instructions are not observed ▶ 8 [28].

2.3 Notes on safe operation

Disregarding the instructions for safe operation can make the product unsafe and risks serious injuries and considerable material damage.

- Observe and comply with all safety instructions and warnings as well as the specifications in the assembly and operating manual.
- Use the product as intended ▶ 2.1 [8].
- All work may only be performed by appropriately qualified personnel ▶ 2.4 [10].
- Rectify malfunctions as soon as they occur ▶ 2.8 [12].
- Never deactivate safety installations.
- Observe safety distances.
- Before commissioning the product, take suitable protective measures to secure the danger zone.
- Secure the system against accidental operation during all work.
- Disconnect power sources before installation, modification, maintenance, or calibration. Ensure that no residual energy remains in the system.
- If the energy supply is connected, do not move any parts by hand.
- Never step into the danger zone during operation.
- Do not reach into the movement area of the product or into the open mechanism during operation.
- Avoid any manner of working that may interfere with the function and operational safety of the product.
- Comply with the current safety, accident prevention, and environmental protection regulations for the application field of the product.

If you have any questions regarding safe operation, our technical after-sales service is available during our business hours:

Service telephone: +49-7133-103-2956

service.toolholder@de.schunk.com

2.4 Personnel qualifications

Work conducted on and with the product by inadequately qualified personnel can lead to serious injuries and considerable material damage.

- Personnel must have read and understood the complete manual before beginning any work on the product.
- All work may only be performed by appropriately qualified personnel:
 - **Specialist personnel**
Specialist personnel have the specialized training, knowledge, and experience to perform the tasks entrusted to them, to recognize and avoid potential dangers, and know the relevant standards and regulations.
 - **Instructed person**
An instructed person has been instructed by the operator regarding the tasks entrusted to them and the potential dangers of inappropriate handling of the product.

Work on the product	Necessary qualification
Transport	Qualified personnel/ instructed person
Assembly/disassembly	Specialist personnel
Settings/functional testing	Specialist personnel
Operation	Qualified personnel/ instructed person
Maintenance/troubleshooting	Specialist personnel/ SCHUNK service personnel
Disposal	Specialist personnel/ SCHUNK service personnel

2.5 Personal protective equipment

Personal protective equipment is necessary to protect staff in the event of a danger that may interfere with their health or safety at work.

- Observe the valid safety and accident prevention regulations and health & safety at work rules.
- When working on and with the product, wear the required personal protective equipment.
 - Always wear safety boots.
 - Wear close-fitting protective clothing and place a hairnet over long hair when dealing with moving components.
 - Wear protective gloves to guard against sharp edges and corners and rough surfaces.
 - Wear heat-resistant protective gloves when handling hot surfaces.
 - Wear protective gloves and safety goggles when handling hazardous substances.

2.6 Handling during transport

Incorrect handling during transport can make the product unsafe and risks the danger of serious injuries and considerable material damage.

- During transport and handling, secure the product to prevent it from falling.
- Do not walk under suspended loads.
- Do not leave suspended loads unattended.
- Observe the assembly and operating manual specifications for transport.
- Use suitable assembly and transport devices*.
- Take precautions against pinching and crushing.

* Assembly and transportation devices must be able to carry at least twice the attached weight.

2.7 Structural changes

Modifications, changes or reworking, e.g. additional threads or holes, can damage the product or impair its functionality or safety.

- Structural changes should only be made with the written approval of SCHUNK.
- Use only original spare parts and spares authorized by SCHUNK.

2.8 Behavior in case of malfunctions

Incorrect handling during a malfunction can make the product unsafe and risks the danger of serious injuries and considerable material damage.

- Immediately remove the product from operation and report the malfunction to the responsible departments/persons.
- Get appropriately qualified personnel ▶ 2.4 [10] to rectify the malfunction.
- Observe the information on troubleshooting in the assembly and operating manual.
- Faults not described in the assembly and operating manual may only be rectified after consultation with SCHUNK.
- After a malfunction, ensure that the product is able to function properly and no increased risks have arisen.
- Do not recommission the product until the malfunction has been rectified.

2.9 Hazardous points on the product

Hazardous points on the product pose a particular risk. Failure to observe the warnings in the relevant chapters of this manual can result in serious injury and considerable damage to property.

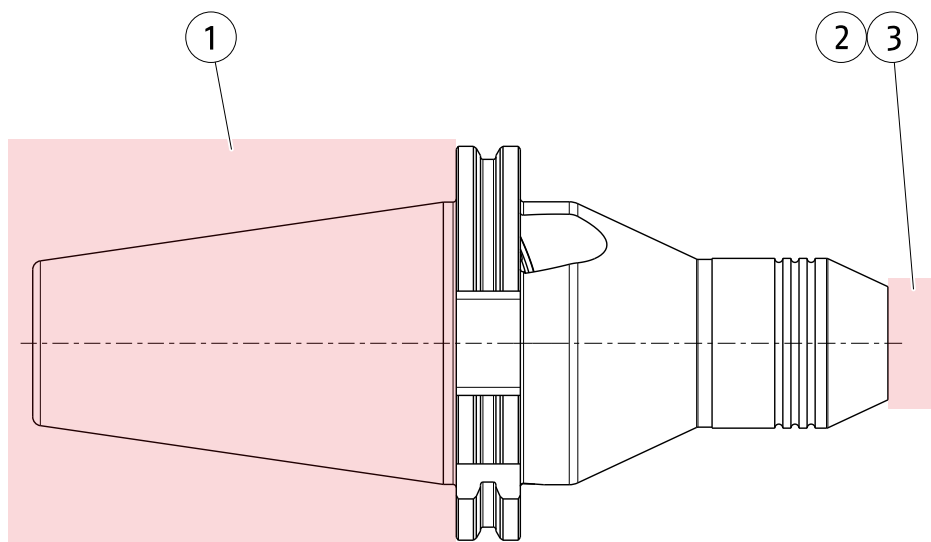

NOTE: Illustration may differ from the actual design.

Position	Danger when	Danger due to
1	Assembling/disassembling the product	Crushing risk
2	Operating/clamping the product	The expansion sleeve bursting
3	Workpiece change	Crushing risk

3 Technical data

3.1 Product data

ID	0219220; 0219221; 0219222; 0219223; 0219224; 0219225; 0219226; 0219227; 0219228; 0219229			
Operation	Grinding			
Insertion position	Horizontal			
Clamping actuation	Manually actuated			
Actuation moment of the clamping screw [Nm]	10			
Maximum permissible speed of rotation [RPM]	1000			
Maximum permissible speed of rotation without workpiece [RPM]	10			
Product mount	Similar to taper SK50 DIN 69871			
Maximum coolant pressure [bar]	80			
ID	0219221	0219222	0219223	0219224
Minimum clamping depth [mm]	28	28	30	36
Maximum transmittable torque, theoretical [Nm]	4	7	14	22
Expansion rate [mm]	0.020	0.024	0.029	0.034
Clamping diameter, product [mm]	6 +0.004/+0.002	8 +0.004/+0.002	10 +0.004/+0.002	12 +0.005/+0.002
Clamping length [mm]	20	20	22.6	27.6
Workpiece diameter [mm]	6 h6 (0/-0.008)	8 h6 (0/-0.009)	10 h6 (0/-0.009)	12 h7 (0/-0.018)
Permissible radial force on the chuck at 50 mm projecting length [N]	225	370	540	650
Weight [kg]	approx. 3.6	approx. 3.6	approx. 3.7	approx. 3.7

ID	0219229	0219225	0219220	0219226
Minimum clamping depth [mm]	36	40	40	43
Maximum transmittable torque, theoretical [Nm]	35	50	70	90
Expansion rate [mm]	0.038	0.043	0.047	0.052
Clamping diameter, product [mm]	14 +0.005/+0.002	16 +0.005/+0.002	18 +0.005/+0.002	20 +0.006/+0.003
Clamping length [mm]	27.6	32.1	32.1	35
Workpiece diameter [mm]	14 h7 (0/-0.018)	16 h7 (0/-0.018)	18 h7 (0/-0.018)	20 h7 (0/-0.021)
Permissible radial force on the chuck at 50 mm projecting length [N]	900	1410	1580	1860
Weight [kg]	approx. 3.7	approx. 3.8	approx. 3.8	approx. 3.9

ID	0219227	0219228
Minimum clamping depth [mm]	43	53
Maximum transmittable torque, theoretical [Nm]	100	250
Expansion rate [mm]	0.057	0.080
Clamping diameter, product [mm]	22 +0.006/+0.003	32 +0.006/+0.003
Clamping length [mm]	35	44.9
Workpiece diameter [mm]	22 h7 (0/-0.021)	32 h7 (0/-0.025)
Permissible radial force on the chuck at 50 mm projecting length [N]	4400	6500
Weight [kg]	approx. 3.9	approx. 4.0

3.2 Ambient conditions and operating conditions

Specification	Value
Operating temperature range	+18°C to +25°C
Maximum product temperature	+35°C
Test temperature range for the expansion rate check	+23°C ±2°C
Storage temperature range	+20°C ±10°C
Relative air humidity	20 to 80%

NOTE: The temperatures refer to the product.

4 Design and description

4.1 Design

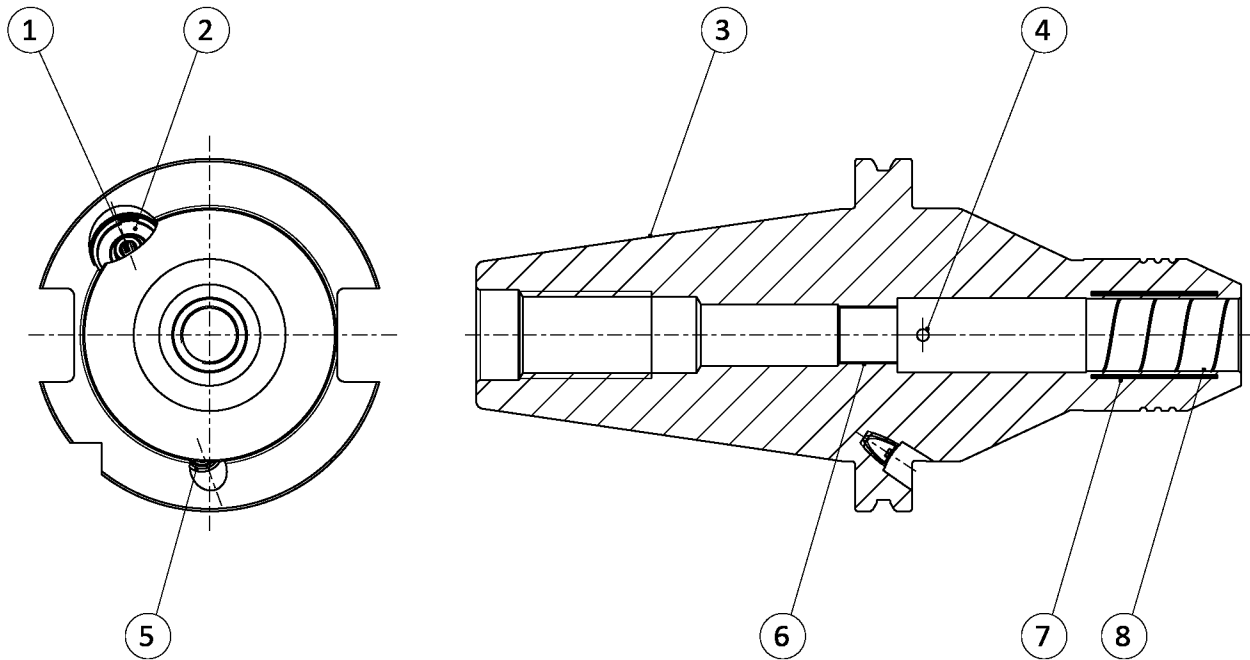

NOTE: Illustration may differ from the actual design.

Position	Description
1	Clamping screw
2	Dirt cover
3	Product mount
4	Pressurized air hole
5	Air bleed screw
6	Length-setting screw thread
7	Active clamping length
8	Clamping surface

4.2 Description of function

This product clamps hydraulically by means of manual actuation. The piston with stroke limitation is actuated via a clamping screw. To achieve the full clamping force, the clamping screw must be screwed in until it reaches the stop. The stroke limitation protects the product against over-expansion.

The volume of oil that is squeezed out of the piston chamber is pressed in measured amounts against the thin-walled expansion sleeve. The resulting internal pressure radially presses against the thin-walled expansion sleeve, causing the clamping range to expand evenly along the entire active clamping length, centrally equal to the middle axis. The workpiece is clamped.

By turning back the clamping screw and the associated pressure relief in the piston chamber and the expansion chamber, the thin-walled expansion sleeve returns exactly to its initial position in the radial direction. The workpiece can be removed.

5 Assembly

5.1 Basic information



⚠ WARNING

Risk of injury due to incorrect assembly!

If assembled incorrectly, the product may be flung out during rotation, causing severe injuries.

- Regularly check the fastening of the product.
- Secure the danger zone by taking suitable protective measures.
- Wear suitable protective equipment.



⚠ WARNING

Risk of injury if the product falls during transport, assembly or disassembly!

Due to the oily surface required to preserve it, the product can slip through your hands, resulting in injury.

- Take appropriate safety measures to prevent the product from falling.
- Only install the product on machines with the appropriate connection dimensions.
- Wear suitable protective equipment, especially safety gloves.



⚠ CAUTION

Risk of crushing and impact when assembling and disassembling the product!

- Do not reach between the product and machine.
- Wear suitable protective equipment.

NOTICE

Possible damage to the expansion sleeve!

- When transporting and handling the product, ensure that it is not damaged by knocks, impacts, etc.
- It is essential that the thin-walled clamping face (expansion sleeve) is protected against shocks and impacts.

5.2 Assembly of the product

To ensure optimal machining results, the product must be precisely positioned and secured on the machine interface.

NOTE: Only mount the product and attachments on machines with suitable connection dimensions. Observe the mounting instructions from the machine interface manufacturer.

NOTE: Cap nut and safety ring are not included in the scope of delivery.

1. Clean all interfaces on the product and machine.
2. Place the product on the machine interface in the correct position and fit it as far as the stop.
3. Fasten the product to the mount with a suitable cap nut (provided by the customer) in accordance with the manufacturer's specifications. The cap nut can be additionally secured with a safety ring (provided by the customer).

NOTICE! Safe and correct mounting of the product on the machine interface must be ensured!

6 Settings and functional testing

6.1 Basic information



⚠ WARNING

Risk of injury and material damage due to the expansion sleeve cracking.

If the expansion sleeve cracks, oil may be emitted at high pressure and chips or broken pieces may fly off, causing severe injuries.

- Avoid knocking or banging the expansion sleeve.
- The specified expansion rate may not be exceeded.
- Observe the inspection temperature specified in the technical data to check the expansion rate.
- Secure the danger zone by taking suitable protective measures.
- Wear suitable protective equipment.

To ensure correct operation and to test the product functions, various settings and functional checks must be carried out before initial operation. These may vary depending on the version and are described in the following sub-chapters.

NOTE: The product may only be operated without a workpiece for the settings and functional tests!

If you have any questions regarding settings and functional tests, our technical after-sales service is available during our business hours:

Service telephone: +49-7133-103-2956
service.toolholder@de.schunk.com

6.2 Checking the expansion rate

Before initial operation, the expansion rate must be checked using a corresponding measuring device with a measurement resolution of 0.001 mm. When doing this, clamp the product without a workpiece.

1. Observe the technical data ▶ 3 [14] and the marking on the product.
2. Unscrew clamping screw up to the safety ring.
NOTICE! The clamping screw must not be unscrewed further, otherwise the product could get damaged!
3. Measure the clamping diameter of the unclamped product using the measuring device. Use the center of the clamping diameter as the measuring point for this.
4. Screw in the clamping screw as far as the stop. Observe the stated actuation moment ▶ 3 [14].
5. Measure the clamping diameter again at the same position.
6. The difference resulting from both measurements can now be compared with the expansion rate specified in the technical data. ▶ 3 [14]

6.3 Checking the clamping function

1. Observe the technical data ▶ 3 [14] and the marking on the product.
2. Make sure that the product is mounted correctly.
3. Make sure that the product is in an unclamped state.
4. Place the test workpiece on the product in the correct position and up to the stop without exerting too much force.
IMPORTANT! Observe the minimum clamping depth ▶ 3 [14]!
5. Screw in the clamping screw as far as the stop. Adhere to the specifications for the actuation moment ▶ 3 [14].
6. Check that the test workpiece is firmly in place.

7 Operation

7.1 Basic information



⚠ WARNING

Risk of injury when the product is rotating, due to the possibility of parts flying off!

- Comply with the technical data.
- Make sure the attachments and operating components present are installed and fitted correctly.
- Check the clamping force regularly.
- Take appropriate protective measures to secure danger zones.
- Wear suitable protective equipment.



⚠ WARNING

Risk of injury due to the workpiece being flung out if the speed of rotation is too high or not suitable!

- Comply with the technical data.
- Do not exceed the maximum speed.
- Reduce the speed of rotation appropriately in case of far protruding workpieces or workpieces balanced asymmetrically.
- Take appropriate protective measures to secure danger zones.
- Wear suitable protective equipment.



⚠ WARNING

Risk of injury and material damage due to the expansion sleeve cracking.

If the expansion sleeve cracks, oil may be emitted at high pressure and chips or broken pieces may fly off, causing severe injuries.

- Avoid knocking or banging the expansion sleeve.
- Always cover the entire clamping length of the product.
- The specified expansion rate may not be exceeded.
- When the product is tensioned, do not exceed the maximum permissible operating temperature.
- Only operate the product within the optimum operating temperature range.
- Secure the danger zone by taking suitable protective measures.
- Wear suitable protective equipment.

**⚠ CAUTION****Risk of crushing, knocks, and cutting when changing workpieces!**

- When changing the workpiece, do not reach in between the product and the workpiece.
- Prevent unintentional actuation of the product.
- Wear suitable protective equipment, especially protective gloves.

NOTICE**Possibility of increased wear, reduced service life, and reduced accuracy of the expansion sleeve.**

If the surface to be clamped on the workpiece is interrupted, the thin-walled expansion sleeve will over-expand at these points (lack of back pressure!).

- Interruptions should be avoided along the surface of the workpiece to be clamped.
- Cover the complete active clamping length of the product.

7.2 Clamping the workpiece

The product must be unclamped when loading the workpiece. Initial tension inhibits loading and can damage the expansion sleeve.

CAUTION! The workpiece to be clamped must be deburred at the surfaces that come into contact with the product, may not have sharp contours and must be free of oil, grease and dirt.

When fitting and clamping the workpiece, the following points must be taken into account:

- It is important to ensure that the product is first securely clamped on the machine interface before the workpiece is loaded and clamped.
- The workpiece must be inserted to at least to the minimum clamping depth before clamping.

For clamping, proceed as follows:

1. Observe the technical data ▶ 3 [□ 14] and the marking on the product.
2. Make sure that the product is mounted correctly.
3. Make sure that the product is in an unclamped state.
4. Clean any dust and dirt from all product surfaces that come into contact with the workpiece.
5. If necessary, mount a suitable intermediate sleeve ▶ 7.4 [□ 25].
6. Place the workpiece on the product in the correct position and up to the stop without exerting too much force.
IMPORTANT! Observe the minimum clamping depth ▶ 3 [□ 14]!
7. Screw in the clamping screw as far as the stop. Adhere to the specifications for the actuation moment ▶ 3 [□ 14].
IMPORTANT! The clamping screw may only be actuated by hand!
8. Check that the workpiece is firmly in place.

7.3 Unclamping the workpiece

1. Carefully unscrew the clamping screw as far as the dirt cover. The actuating screw may only touch the dirt cover lightly, otherwise it may become stuck (jams with the dirt cover).
NOTICE! The clamping screw must not be unscrewed further, otherwise the product could get damaged!
2. Remove workpiece.

7.4 Using the intermediate sleeve



⚠ WARNING

Risk of injury due to the intermediate sleeve being hurled out or breaking

The intermediate sleeve may break or be ejected when the product is operated without a workpiece.

- Only operate the product with a clamped workpiece.
- Take suitable protective measures to secure the danger zone.

NOTICE

Impairment of the clamping function and damage to the product!

The use of incorrect or unsuitable intermediate sleeves may impair the clamping function of the product or damage the product.

- Comply with the technical data.
- Only use suitable and approved intermediate sleeves.

Depending on the design of the product, an intermediate sleeve is required to reduce the clamping diameter. It is possible to use different types of intermediate sleeves with this product. We generally recommend the use of intermediate sleeves from SCHUNK.

NOTICE! Only mount or change the intermediate sleeve when the product is unclamped!

NOTICE! When using an intermediate sleeve, never operate the product without a clamped workpiece!

7.4.1 Assembly/disassembly of the intermediate sleeve

The following intermediate sleeves can be used to reduce the clamping diameter:

- Intermediate sleeve without lock
Suitable for manual intermediate sleeve change and manual tool change

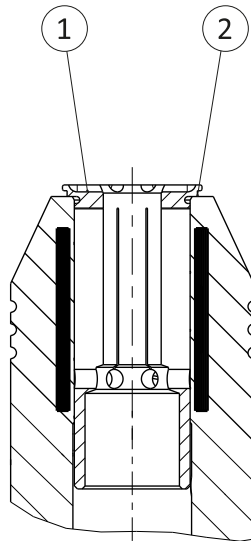

NOTE: Illustration may differ from the actual design.

Position	Description
1	Intermediate sleeve without lock
2	Stop face, intermediate sleeve

7.4.1.1 Intermediate sleeve without lock

Assembly

1. Make sure that the product is in an unclamped state.
2. Place the intermediate sleeve on the product in the correct position and fit it as far as the stop without exerting too much force.

Disassembly

1. Remove workpiece ▶ 7.3 [📄 24].
2. Make sure that the product is in an unclamped state.
3. Carefully and evenly pull out the intermediate sleeve, keeping it parallel. For this purpose, we recommend the use of a sleeve remover.

NOTICE! Danger of cutting injuries when changing the intermediate sleeve with workpiece! We always recommend using the workpiece and intermediate sleeve separately.

8 Maintenance

8.1 Basic information



⚠ WARNING

Risk of injury and material damage due to the expansion sleeve cracking.

If the expansion sleeve cracks, oil may be emitted at high pressure and chips or broken pieces may fly off, causing severe injuries.

- Avoid knocking or banging the expansion sleeve.
- The specified expansion rate may not be exceeded.
- Observe the inspection temperature specified in the technical data to check the expansion rate.
- Secure the danger zone by taking suitable protective measures.
- Wear suitable protective equipment.



⚠ CAUTION

Injury of the eyes due to dirt particles!

When cleaning with compressed air, the eyes may be injured by flying dirt particles.

- Wear suitable protective equipment, particularly protective goggles.

NOTICE

Possible damage to the product and function restrictions!

Removing components of the product may disable an additional function or damage the product by allowing an ingress of particles.

- Attachments are only allowed to be removed if this is expressly described in the operating manual or if written approval has been obtained from SCHUNK.

For trouble-free, long-lasting use, clean, maintain and check the functionality of the product regularly.

Repair work may only be carried out by SCHUNK!

If you have any questions regarding maintenance and servicing, our technical after-sales service is available during our business hours:

Service telephone: +49-7133-103-2956

service.toolholder@de.schunk.com

8.2 Intervals and tasks

Operation	Interval period
Clean the clamping surface and workpiece stop face	after every clamping procedure
Cleaning the product	daily
Cleaning the pressurized air hole	weekly or after 1000 clampings
Check the expansion rate	weekly or after 1000 clampings
Check and lubricate the clamping screw	monthly or after 1000 clampings
Polish the clamping surface	weekly or after 1000 clamping operations as required
Disassembly/change of the intermediate sleeve	for workpiece changes, for maintenance purposes, in the event of damage or signs of wear

The specified maintenance intervals are based on empirical data gathered by SCHUNK and are a recommendation. Depending on the ambient and operating conditions, as well as the clamping frequency of the product, the maintenance intervals need to be adapted and noted accordingly. For maintenance intervals with two or more specifications, the specification that applies first is valid.

After completing essential maintenance work, any settings and functional tests must be carried out again ▶ 6 [📄 20].

8.2.1 Clean the clamping surface and workpiece stop face

1. Remove workpiece ▶ 7.3 [24].
2. Make sure that the product is in an unclamped state.
3. Clean clamping face and workpiece stop face with compressed air.
4. Wipe the surfaces dry with a clean cloth.

8.2.2 Cleaning the product

1. Remove workpiece ▶ 7.3 [24].
2. Make sure that the product is in an unclamped state.
3. Clean the entire product with compressed air.
4. Carefully remove any stubborn dirt with a suitable tool.
5. Wipe all surfaces dry with a clean cloth.
6. Check the product for deformation, damage or wear, in particular the surfaces that come in contact with the workpiece and replace if necessary.

NOTE: Damage or wear can compromise the functioning of the product. If non-replaceable parts of the product are worn or damaged, return the product to SCHUNK for inspection.

8.2.3 Cleaning the pressurized air hole

1. Remove workpiece ▶ 7.3 [24].
2. Clean the pressurized air hole with compressed air.
3. Carefully remove any stubborn dirt with a suitable tool.

8.2.4 Check the expansion rate

The expansion rate should be checked by measuring the clamping diameter according to the specifications in the maintenance table. To do this, use a suitable measuring device with a measurement resolution of 0.001 mm.

For inspection, proceed as follows.

1. Observe the technical data ▶ 3 [14] and the marking on the product.
2. Remove workpiece ▶ 7.3 [24].
3. Remove the intermediate sleeve if mounted. ▶ 8.2.7 [38]
4. Make sure that the product is mounted correctly.
5. Measure the clamping diameter of the unclamped product using the measuring device. Use the center of the clamping face as the measuring point for this.
6. Screw in the clamping screw as far as the stop. Adhere to the specifications for the actuation moment ▶ 3 [14].
IMPORTANT! The clamping screw may only be actuated by hand!
7. Measure the clamping diameter again at the same position.
8. The difference resulting from both measurements must match the expansion rate specified in the technical data.

NOTICE! Observe the specified test temperature for the expansion rate check.

If the expansion rate specified in the technical data is not achieved, then

- the hydraulic system has lost too much oil,
- or the clamping diameter is heavily worn.

In this case, send the product to SCHUNK for inspection.

8.2.5 Check and lubricate the clamping screw



⚠ CAUTION

Allergic reactions if lubricating grease comes into contact with the skin.

- Wear protective gloves.

In order to prevent wear to the clamping screw, we recommend that it be lubricated using a method suited to the operating and ambient conditions. This is especially relevant in case of:

- high clamping frequency
- high operating temperature
- intensive cleaning (in a washing system)

For optimum clamping screw lubrication, we recommend copper paste type MOLYKOTE CU 7439. (100 g tube, ID 9247204).

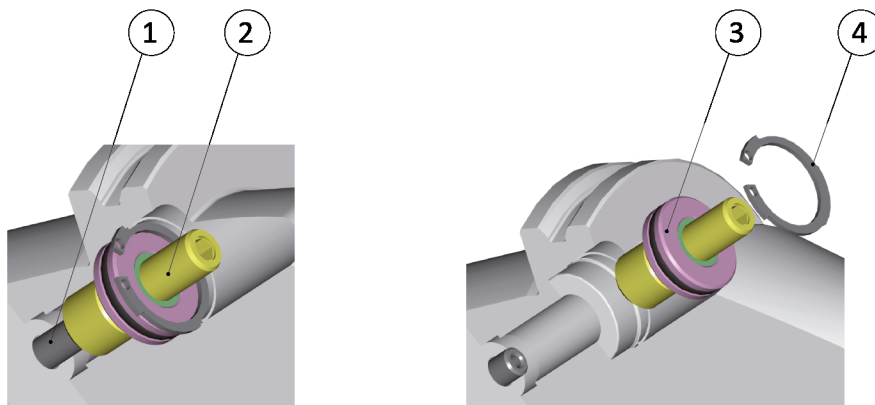

Position	Description
1	Clamping piston
2	Clamping screw
3	Dirt cover with seal
4	Safety ring

When lubricating, proceed as follows:

1. Remove the safety ring using a suitable tool.
2. Unscrew the clamping screw with the dirt cover from the product and remove it.
NOTICE! The clamping piston underneath is not secured against falling out and must not be removed.
3. Clean the clamping screw and check for damage or wear to the thread flanks. Replace if necessary. ▶ 1.4 [📄 7]
4. Lubricate the clamping screw and actuating thread in accordance with the operating conditions.
5. Make sure that the clamping piston is inserted.
6. Screw in the clamping screw and dirt cover as far as the stop. Adhere to the specifications for the actuation moment ▶ 3 [📄 14].
7. Insert the safety ring using a suitable tool.
8. Carefully unscrew the clamping screw as far as the dirt cover.
NOTICE! The clamping screw must not be unscrewed further, otherwise the product could get damaged!

8.2.6 Polish the clamping surface

If the clamping surface becomes soiled during operation, it can be difficult to insert workpieces. To remove the impurities, the affected surfaces must be polished.

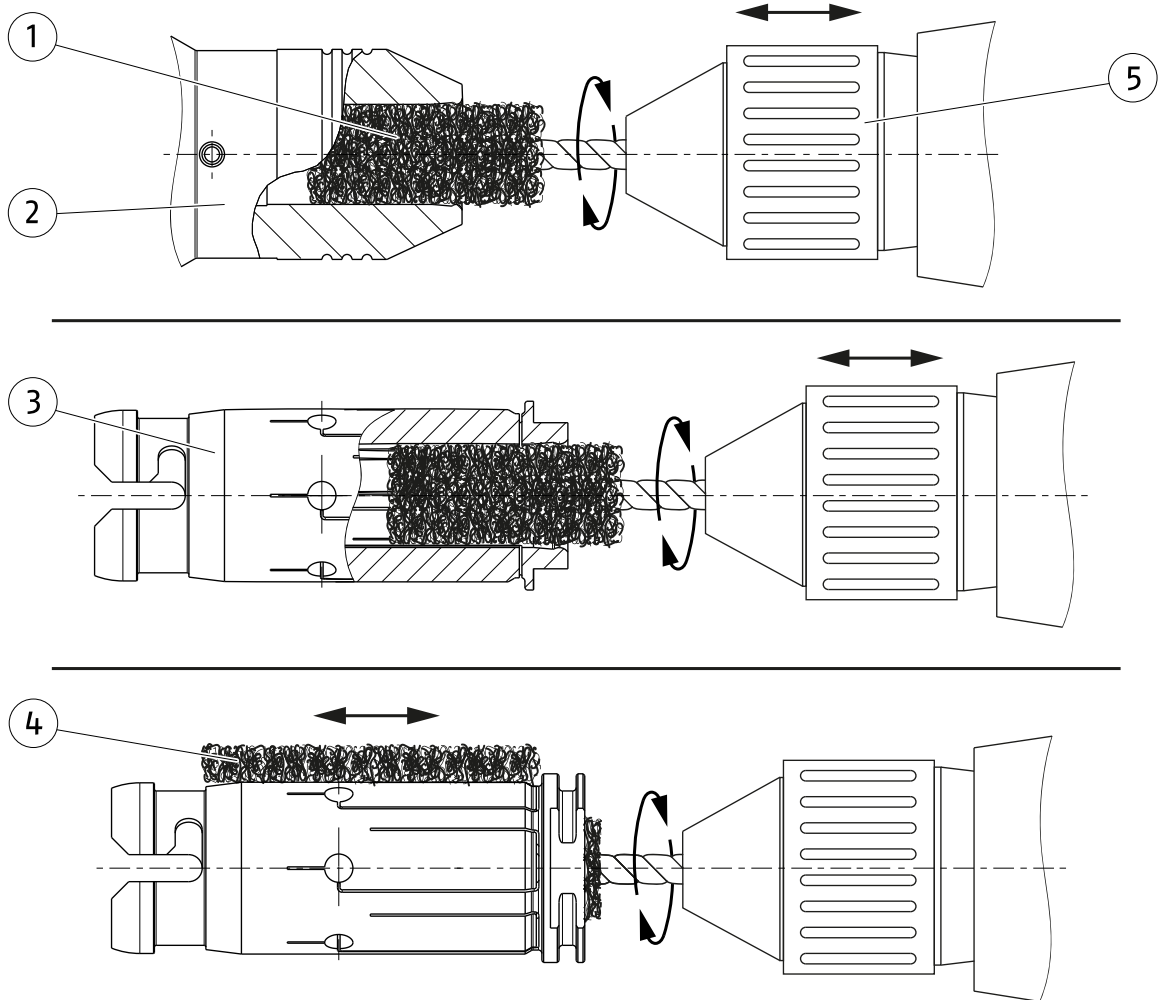

NOTE: Illustration is for reference only.

Position	Description
1	Tube brush wrapped with abrasive fleece
2	Product
3	Intermediate sleeve (if present)
4	Abrasive fleece
5	Cordless screwdriver

NOTE

If you have any questions regarding polishing, our technical after-sales service is available during our business hours.

Service telephone: +49-7133-103-2956
service.toolholder@de.schunk.com

8.2.6.1 Polishing the product's clamping surface

1. Remove workpiece ▶ 7.3 [24].
2. Make sure that the product is in an unclamped state.
3. If present, remove the: intermediate sleeve ▶ 7.4 [25].
4. If present, remove all intermediate sleeve locks such as set-screws.
5. Select a suitable pipe brush. **NOTE:** The diameter of the pipe brush must be 2 mm less than the clamping diameter of the product.
6. Clamp the pipe brush in the cordless screwdriver. Observe the specifications in the cordless screwdriver operating manual.
7. Wrap the abrasive fleece around the pipe brush.
8. Secure product against twisting.
9. Insert the pipe brush wrapped with abrasive fleece into the clamping bore.
10. Actuate cordless screwdriver, thereby
 - ⇒ not exceeding a speed of 1200 RPM and
 - ⇒ move the pipe brush wrapped with the abrasive fleece back and forth several times.
11. Remove the pipe brush wrapped with abrasive fleece from the clamping bore.
12. Clean the clamping bore with a clean cloth and compressed air to remove residue from the polishing process.
13. Insert the test workpiece. **NOTE:** If the test workpiece cannot be inserted smoothly, repeat steps 7 to 12.
14. If required, install intermediate sleeve fuses.
15. If required, install the intermediate sleeve ▶ 7.4 [25].

8.2.6.2 Polishing the clamping surfaces of the intermediate sleeve

For polishing the bore of the intermediate sleeve:

1. Remove the intermediate sleeve ▶ 7.4 [25].
2. Select a suitable pipe brush. **NOTE:** The diameter of the pipe brush must be 2 mm less than the borehole of the intermediate sleeve.
3. Clamp the pipe brush in the cordless screwdriver. Observe the specifications in the cordless screwdriver operating manual.
4. Wrap the abrasive fleece around the pipe brush.
5. Secure the intermediate sleeve against twisting.
6. Insert the pipe brush wrapped with abrasive fleece into the clamping bore.
7. Actuate cordless screwdriver, thereby
 - ⇒ not exceeding a speed of 1200 RPM and
 - ⇒ move the pipe brush wrapped with the abrasive fleece back and forth several times.
8. Clean the clamping bore with a clean cloth and compressed air to remove residue from the polishing process.
9. Remove any dirt stuck in the slots of the intermediate sleeve using a suitable feeler gauge.
10. Insert the test workpiece. **NOTE:** If the test workpiece cannot be inserted easily, repeat steps 4 to 9.
11. Mount intermediate sleeve ▶ 7.4 [25].

Polishing the sheath surface of the intermediate sleeve:

1. Remove the intermediate sleeve ▶ 7.4 [📄 25].
2. Select a suitable pipe brush. **NOTE:** The diameter of the pipe brush must be 2 mm less than the borehole of the intermediate sleeve.
3. Clamp the pipe brush in the cordless screwdriver. Observe the specifications in the cordless screwdriver operating manual.
4. Wrap the abrasive fleece around the pipe brush.
5. Insert the pipe brush wrapped with abrasive fleece into the clamping bore.
 - ⇒ The intermediate sleeve is clamped and rotates when the cordless screwdriver is actuated.
6. Actuate cordless screwdriver, thereby
 - ⇒ not exceeding a speed of 1200 RPM.
7. Press the abrasive fleece against the sheath surface and move it back and forth several times.
8. Clean the sheath surface of residue from the polishing procedure using a clean cloth and compressed air.
9. Remove any dirt stuck in the slots of the intermediate sleeve using a suitable feeler gauge.
10. Insert the intermediate sleeve into an unclamped product (e.g. tool grinding chuck). **NOTE:** If the intermediate sleeve cannot be inserted easily, repeat steps 4 to 9 or check the clamping bore of the product and polish if necessary.
11. Mount intermediate sleeve ▶ 7.4 [📄 25].

8.2.7 Disassembly/changing of the intermediate sleeve

Any inserted intermediate sleeve must be disassembled for maintenance. If there are signs of wear or damage, the intermediate sleeve must be replaced.

NOTICE! Only change the intermediate sleeve when the product is unclamped!

8.2.7.1 Intermediate sleeve without lock

Disassembly

1. Remove workpiece ▶ 7.3 [24].
2. Make sure that the product is in an unclamped state.
3. Carefully and evenly pull out the intermediate sleeve, keeping it parallel. For this purpose, we recommend the use of a sleeve remover.

Assembly

1. Make sure that the product is in an unclamped state.
2. Place the intermediate sleeve on the product in the correct position and fit it as far as the stop without exerting too much force.

9 Troubleshooting

Malfunction/error	Possible cause	Solution(s)
Workpiece is not clamped	Clamping screw is not screwed in as far as the stop	Screw the clamping screw in until it reaches the stop
	Wear on the clamping diameter	Send the product to SCHUNK for inspection
	Oil loss on the product	Send the product to SCHUNK for inspection
	Clamping piston was removed during lubrication of the clamping screw	Insert clamping piston into product
Workpiece cannot be joined	Product is not completely unclamped	Unclamping the product ▶ 7.3 [📄 24]
	Solidified dirt on the clamping surface	Polish the clamping surface ▶ 8.2.6 [📄 34]
Workpiece cannot be removed	Product is not completely unclamped	Unclamping the product ▶ 7.3 [📄 24]
Insufficient run-out accuracy	Product is not correctly positioned on the machine interface	Clean the contact surfaces of the product and machine
	With flange mounting: mounting screws are not tightened correctly	Adhere to the specified tightening torque ▶ 3 [📄 14]

If you have any questions regarding troubleshooting, our technical after-sales service is available during our business hours:

Service telephone: +49-7133-103-2956
service.toolholder@de.schunk.com

10 Disassembly

10.1 Basic information



⚠ WARNING

Risk of injury if the product falls during transport, assembly or disassembly!

Due to the oily surface required to preserve it, the product can slip through your hands, resulting in injury.

- Take appropriate safety measures to prevent the product from falling.
- Only install the product on machines with the appropriate connection dimensions.
- Wear suitable protective equipment, especially safety gloves.



⚠ CAUTION

Risk of crushing and impact when assembling and disassembling the product!

- Do not reach between the product and machine.
- Wear suitable protective equipment.

NOTICE

Possible damage to the expansion sleeve!

- When transporting and handling the product, ensure that it is not damaged by knocks, impacts, etc.
- It is essential that the thin-walled clamping face (expansion sleeve) is protected against shocks and impacts.

10.2 Disassembly of the product

1. Remove workpiece ▶ 7.3 [24].
2. If present, remove the safety ring of the cap nut.
3. Remove the cap nut.
4. Remove the product.

NOTE: To avoid damage, only place the product on a clean and soft surface.

11 Storage

When storing the product for a longer period of time, observe the following points:

- Ensure that the product is in an unclamped state.
- Clean and lightly oil the product and intermediate sleeve.
- Store the product and intermediate sleeve in a suitable transport container.
- Only store the product and intermediate sleeve in dry rooms.
- Protect the product and intermediate sleeve from excessive temperature fluctuations.
- Comply with the storage temperature specified in the technical data.

NOTE: Before reassembling, clean the product and all attachments ▶ 8.2.2 [📄 30], and check for damage, functionality and tightness. After assembly, all settings and function tests must be carried out ▶ 6 [📄 20].

12 Disposal

When disposing of the product, observe the following points:

- Collect any escaping liquids and dispose of them properly in line with the statutory provisions.
- Follow local regulations on dispatching product components for recycling or proper disposal.

NOTE: Alternatively, you can return the product to SCHUNK for correct disposal.

13 Drawings

The assembly and operating manual as well as the valid drawing can be requested in digital format by stating the product ID.

For this, contact our technical after-sales service:

service.toolholder@de.schunk.com



SCHUNK SE & Co. KG
Spanntechnik | Greiftechnik | Automatisierungstechnik

Bahnhofstr. 106 – 134
D-74348 Lauffen/Neckar
Tel. +49-7133-103-0
info@de.schunk.com
schunk.com

Folgen Sie uns | *Follow us*



Wir drucken nachhaltig | *We print sustainable*