



Assembly and operating manual

MFT

Radially flexible grinding, polishing and
brushing spindle

Original manual

Hand in hand for tomorrow

Imprint

Copyright:

This manual is protected by copyright. The author is SCHUNK SE & Co. KG.
All rights reserved.

Technical changes:

We reserve the right to make alterations for the purpose of technical improvement.

Document number: 389545

Version: 05.00 | 20/02/2025 | en

Dear Customer,

Thank you for trusting our products and our family-owned company, the leading technology supplier of robots and production machines.

Our team is always available to answer any questions on this product and other solutions. Ask us questions and challenge us. We will find a solution!

Best regards,

Your SCHUNK team

Customer Management

Tel. +49-7133-103-2503

Fax +49-7133-103-2189

cmg@de.schunk.com



Please read the operating manual in full and keep it close to the product.

Table of Contents

1	General	5
1.1	About this manual	5
1.1.1	Presentation of Warning Labels	5
1.1.2	Applicable documents	6
1.2	Warranty	6
1.3	Scope of delivery	6
2	Basic safety notes	7
2.1	Intended use	7
2.2	Not intended use	7
2.3	Constructional changes	7
2.4	Spare parts	8
2.5	Recommended Spare Parts	8
2.6	Environmental and operating conditions	8
2.7	Personnel qualification	8
2.8	Personal protective equipment	9
2.9	Transportation and Protection during Transportation	9
2.10	Safety Precautions	10
3	Technical Specifications	11
4	Description and function	14
4.1	Description	14
4.2	Spindle Operation and Media Selection	15
5	Assembly and settings	16
5.1	Mechanical connection	16
5.2	Pneumatic Connection	16
5.3	Electrical Connections	18
5.4	Initial Operation	19
5.4.1	Media Considerations	19
5.4.2	Tool Position and Programming	19
6	Maintenance and repair	21
6.1	Routine Operational Maintenance	21
6.2	Media Replacement	21
6.3	Boot Replacement	22
6.4	Air Motor Replacement	22
6.5	Sensor Replacement	24
6.5.1	Sensor for monitoring: Spindle extracted (Option-F)	24
6.5.2	Sensor for monitoring: Spindle retracted (Option-R)	25
6.5.3	Sensor for rotation speed: Tachometer sensor (Option -T)	25

6.6 Pneumatic –lines/–connections	27
6.7 Lubrication of the polishing spindle	27
6.8 Storage and Preventive Maintenance during Storage.....	27
7 Troubleshooting.....	28
7.1 Troubleshooting Matrix.....	28
8 Drawings	29
9 Translation of the original declaration of incorporation	33
10 UKCA declaration of incorporation	34
11 Information on the RoHS Directive, REACH Regulation and Substances of Very High Concern (SVHC)	35

1 General

1.1 About this manual

This manual contains important information for a safe and appropriate use of the product.

This manual is an integral part of the product and must be kept accessible for the personnel at all times.

Before starting work, the personnel must have read and understood this operating manual. Prerequisite for safe working is the observance of all safety instructions in this manual.

In addition to these instructions, the documents listed under ► 1.1.2 [6] are applicable.

NOTE: The illustrations in this manual are intended to provide a basic understanding and may deviate from the actual version.

1.1.1 Presentation of Warning Labels

To make risks clear, the following signal words and symbols are used for safety notes.



⚠ DANGER

Dangers for persons!

Non-observance will inevitably cause irreversible injury or death.



⚠ WARNING

Dangers for persons!

Non-observance can lead to irreversible injury and even death.



⚠ CAUTION

Dangers for persons!

Non-observance can cause minor injuries.

NOTICE

Material damage!

Information about avoiding material damage.

1.1.2 Applicable documents

- General terms of business *
- Catalog data sheet of the purchased product *

The documents labeled with an asterisk (*) can be downloaded from schunk.com/downloads.

1.2 Warranty

Die Gewährleistung für die Radially flexible grinding, polishing and brushing spindle MFT beträgt 24 Monate. Der Luftmotor ist hiervon ausgenommen.

Die Gewährleistung des Luftmotors beträgt 1000 Betriebsstunden bei ölfreiem Betrieb oder 12 Monate ab Lieferdatum Werk; maßgeblich ist das früher eintretende Ereignis.

Werkstückberührende Teile und Verschleißteile sind nicht Bestandteil der Gewährleistung.

1.3 Scope of delivery

The scope of delivery includes

- Radially flexible grinding, polishing and brushing spindle MFT in the version ordered
- Safety information (product-specific instructions available online)
- 1x wrench (15 mm)

2 Basic safety notes

2.1 Intended use

The Radially flexible grinding, polishing and brushing spindle MFT is intended to perform robotic and non-robotic material finishing operations.

- The product may only be used within the scope of its technical data.
- The product is intended for industrial use.
- The product is intended for installation in a machine/ automated system or for attachment to a robot. The applicable guidelines for the machine/automated system must be observed and complied with.
- Appropriate use of the product includes compliance with all instructions in this manual.
- When implementing and operating components in safety-related parts of the control systems, the basic safety principles in accordance with DIN EN ISO 13849-2 apply. The proven safety principles in accordance with DIN EN ISO 13849-2 also apply to categories 1, 2, 3 and 4.

2.2 Not intended use

It is not intended use if the product is used, for example, as a pressing tool, stamping tool, lifting gear, guide for tools, cutting tool, clamping device or a drilling tool.

- Any utilization that exceeds or differs from the appropriate use is regarded as misuse.

2.3 Constructional changes

Implementation of structural changes

Modifications, changes or reworking, e.g. additional threads, holes, or safety devices, can damage the product or impair its functionality or safety.

- Structural changes should only be made with the written approval of SCHUNK.

2.4 Spare parts

Use of unauthorized spare parts

Using unauthorized spare parts can endanger personnel and damage the product or cause it to malfunction.

- Use only original spare parts or spares authorized by SCHUNK.

2.5 Recommended Spare Parts

For repair and spare parts please contact SCHUNK. For an exploded drawing showing all the components of the MFT, see ▶ 8 [📄 29].

2.6 Environmental and operating conditions

Required ambient conditions and operating conditions

Incorrect ambient and operating conditions can make the product unsafe, leading to the risk of serious injuries, considerable material damage and/or a significant reduction to the product's life span.

- Make sure that the product is used only in the context of its defined application parameters, ▶ 3 [📄 11].
- The Radially flexible grinding, polishing and brushing spindle MFT should only be used in an automated cell/chamber.
- The work cell must be secured by means of barriers to prohibit personnel from entering the cell. A lockable door should be included as a part of the barrier in order to facilitate access to the cell for authorized personnel only. The barrier could consist partly or fully of Plexiglas to facilitate observation of the manufacturing process.
- Be aware of high sound levels. While the Radially flexible grinding, polishing and brushing spindle MFT air motor is not loud, the cutting action associated with many processes frequently is. Always use hearing protection while working in the neighborhood of the production cell.

2.7 Personnel qualification

Inadequate qualifications of the personnel

If the personnel working with the product is not sufficiently qualified, the result may be serious injuries and significant property damage.

- All work may only be performed by qualified personnel.
- Before working with the product, the personnel must have read and understood the complete assembly and operating manual.

- Observe the national safety regulations and rules and general safety instructions.

The following personal qualifications are necessary for the various activities related to the product:

Trained electrician	Due to their technical training, knowledge and experience, trained electricians are able to work on electrical systems, recognize and avoid possible dangers and know the relevant standards and regulations.
Qualified personnel	Due to its technical training, knowledge and experience, qualified personnel is able to perform the delegated tasks, recognize and avoid possible dangers and knows the relevant standards and regulations.
Instructed person	Instructed persons were instructed by the operator about the delegated tasks and possible dangers due to improper behaviour.
Service personnel of the manufacturer	Due to its technical training, knowledge and experience, service personnel of the manufacturer is able to perform the delegated tasks and to recognize and avoid possible dangers.

2.8 Personal protective equipment

Use of personal protective equipment

Personal protective equipment serves to protect staff against danger which may interfere with their health or safety at work.

- When working on and with the product, observe the occupational health and safety regulations and wear the required personal protective equipment.
- Observe the valid safety and accident prevention regulations.
- Wear protective gloves to guard against sharp edges and corners or rough surfaces.
- Wear heat-resistant protective gloves when handling hot surfaces.
- Wear protective gloves and safety goggles when handling hazardous substances.
- Wear close-fitting protective clothing and also wear long hair in a hairnet when dealing with moving components.

2.9 Transportation and Protection during Transportation

The MFT is packaged in a crate designed to secure and protect it during transportation. Always use the crate when transporting the MFT in order to minimize the risk of damage.

2.10 Safety Precautions

- Never use or start the MFT without first reading and understanding the operating procedures described in this manual.
- Make sure that the MFT is mounted as described in this manual.
- Never use the MFT for any purposes or in any ways not explicitly described in this manual.
- Make sure that the pneumatic control equipment is connected as described.
- Only original spare parts supplied by SCHUNK must be used.
- Install a barrier to prohibit people from approaching the MFT while in operation.
- Never be present near the MFT while it is started or running. If it is necessary to approach the MFT while in motion, stand behind appropriate Plexiglas windows.
- Be aware of rotating parts.
- Abrasive media must be rated for at least 5,600 1/min.
- Use eye protection.
- Be aware of high sound levels during cutting. Always use hearing protection while working in the neighborhood of the MFT.
- During system or tool maintenance, make sure the MFT and equipment are stopped before entering the cell. Never be present in the cell when the tool is running when installing and testing.

3 Technical Specifications

Main specifications for the axially compliant tool:

Operating temperature [°C]	5 – 35
Storage Temperature [°C]	0 – 45
Pressure medium	clean, dry, filtered, lubricated or not lubricated air. To achieve the optimum engine life, it is recommended to lubricate the air. The use of a coalescing filter and filter elements rated 5 micron or better is recommended.
Air consumption [l/s] at 6.2 bar	9
Motor	Air motor, vane type
Idle Speed [1/min]	5.600
Working Speed (max. power) [1/min]	2.600
Power at 2.600 1/min [W]	390
Continuous torque (max. power) [Nm]	1.4
Starting torque (starting/stall) [Nm]	2.7
Weight total [kg] (w/o adapter)	3.3
Compensation axial (max.) [mm]	15 7 – 8 recommended
Compliance force @ supply pressure of 0.34–4.1 bar [N]	14 – 74
Sspindle air pressure (max.) [bar]	6.2
Air consumption (max.) [l/s]	approximately 9
Oil consumption (recommended)	approximately 3–4 drops of oil per minute (1 drop = 15mm ³) by oil fog at max. air consumption
Fast Tightening Chuck size	3/8 "
Abrasive media	Customer-supplied
Sound Pressure Level [dBA] No-Load at a Distance of 1.5 meters from Tool	< 75 *

- * Because the working environment is unknown, it is impossible to predict the noise that will occur during an operation. The tool may also excite resonant frequencies on equipment to which it is mounted creating higher sound pressure levels than the unit by itself.

The following charts show measured forces relative to applied compliance air pressure. Measurements may vary from one product to another, and should only be treated as nominal.

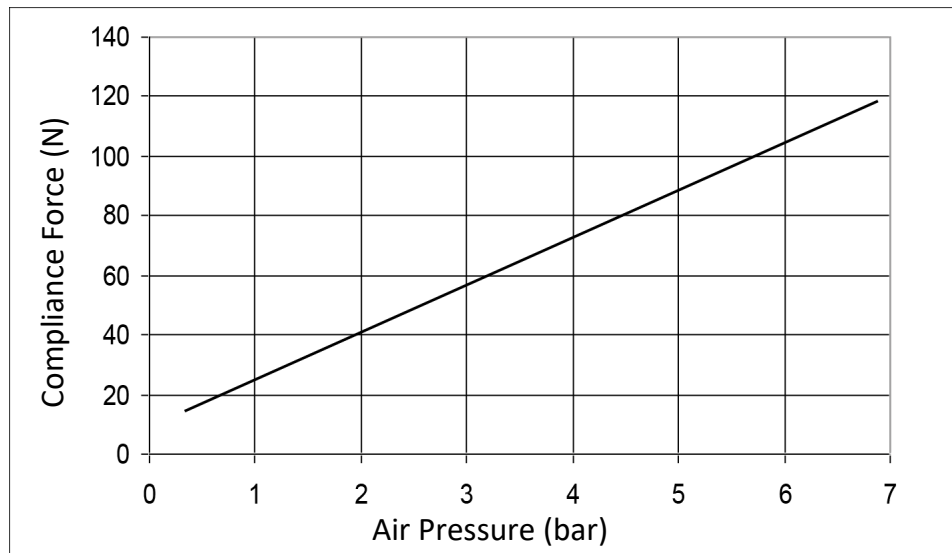

Horizontal Compliance Force Curves

The force characteristics shown graphically above are for horizontal, rigidly-mounted installations. The weight of the motor, chuck, and abrasive media must be added to this if the motor is mounted vertically with the spindle down or subtracted with the spindle pointed up. Units mounted at angles between horizontal and vertical provide a compliance force that must be calculated based on the specific mounting geometry or orientation.

The air motor operating speed will change according to load applied to it developing the power required for the specific task being attempted. The idle speed of the motor will be its maximum as no load is applied. This will drop to a lower operating speed where it will develop the maximum torque. If the torque required exceeds the maximum available, the motor will stall.

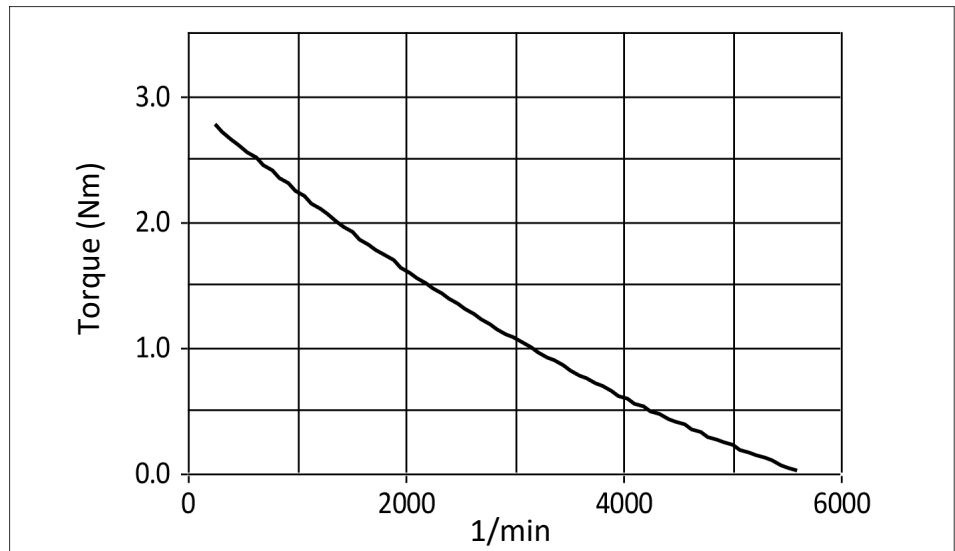

Motor Torque Curves

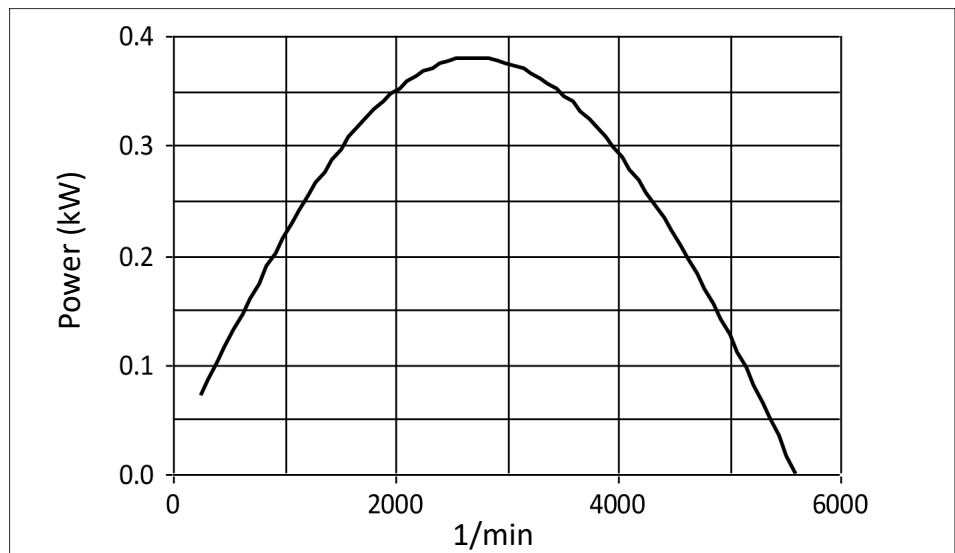

Motor Power Curves

4 Description and function

4.1 Description

NOTICE

- Never use the Radially flexible grinding, polishing and brushing spindle MFT for purposes other than automated processes.
- Never use the Radially flexible grinding, polishing and brushing spindle MFT Never use the

While the Radially flexible grinding, polishing and brushing spindle MFT provides axial travel, it is not designed to eliminate tool chatter which will be experienced in full contact operations, such as countersinking. Rigid tools, such as milling machines, are required for such applications. It may be dangerous to operate the Radially flexible grinding, polishing and brushing spindle MFT for these purposes. If a failure occurs due to forces caused by improper use, hazardous situations for both personnel and equipment could be created.

The Radially flexible grinding, polishing and brushing spindle MFT is not designed to support radial loads. The use of radially used tools (round brushes and grinding rollers) with the unit is not permitted. This can lead to jamming of the round guides and prevent axial movement. In addition, the motor is loaded in an inadmissible manner, which can significantly reduce the service life.

Reduce the feed rate when the work piece and the tool are making initial contact. Making the contact movement between the tool and the work piece too fast may in some situations result in a collision. Collisions may create hazardous situations for both personnel and equipment.

When performing maintenance, always remember to tighten all the fasteners. When replacing media always secure it correctly and insure that the chuck is tightened ▶ 6.1 [21].

The air motor of the Radially flexible grinding, polishing and brushing spindle MFT is equipped with an integral speed reduction gearbox. The life of this gearbox will be reduced.

NOTE

Never use the Radially flexible grinding, polishing and brushing spindle MFT in a manner to produce radial loads. Avoid using the Radially flexible grinding, polishing and brushing spindle MFT for countersinking or drilling.

4.2 Spindle Operation and Media Selection

When used with flexible abrasive media, the Radially flexible grinding, polishing and brushing spindle MFT will perform best when the rotating media approaches the burr in a direction that will fold the burr back on itself. This will allow the media to remove material rapidly without excessive force and without the creation of a secondary burr. This will decrease the cycle time for the operation while extending the life of the tool and the consumable media. The MFT spindle rotates clockwise when viewed from behind.

The selection of such media is highly dependent upon the work piece material and geometry, and the amount of material to be removed. It is not practical to present all the possibilities in this document.

5 Assembly and settings

5.1 Mechanical connection

The product is designed for side mounting.

SCHUNK offers a side interface plate kit for bench mounting.

The product must be rigidly mounted prior to use.

Under no circumstances should the product be used for manual/hand operations.

5.2 Pneumatic Connection

Notes on compressed air supply

Air line fittings supplying the Radially flexible grinding, polishing and brushing spindle MFT should be installed with care using a minimum of tape or liquid sealant.

To prevent contaminant damage to the air motor, all air lines should be blown down to remove debris prior to connection of the Radially flexible grinding, polishing and brushing spindle MFT.

Water damage of the air motor or damage associated with debris in the air lines is not covered under warranty.

Once mounted, the Radially flexible grinding, polishing and brushing spindle MFT should be supplied with clean, filtered and optionally lubricated compressed air.

Connection

Connect the Radially flexible grinding, polishing and brushing spindle MFT as shown in the following figure.

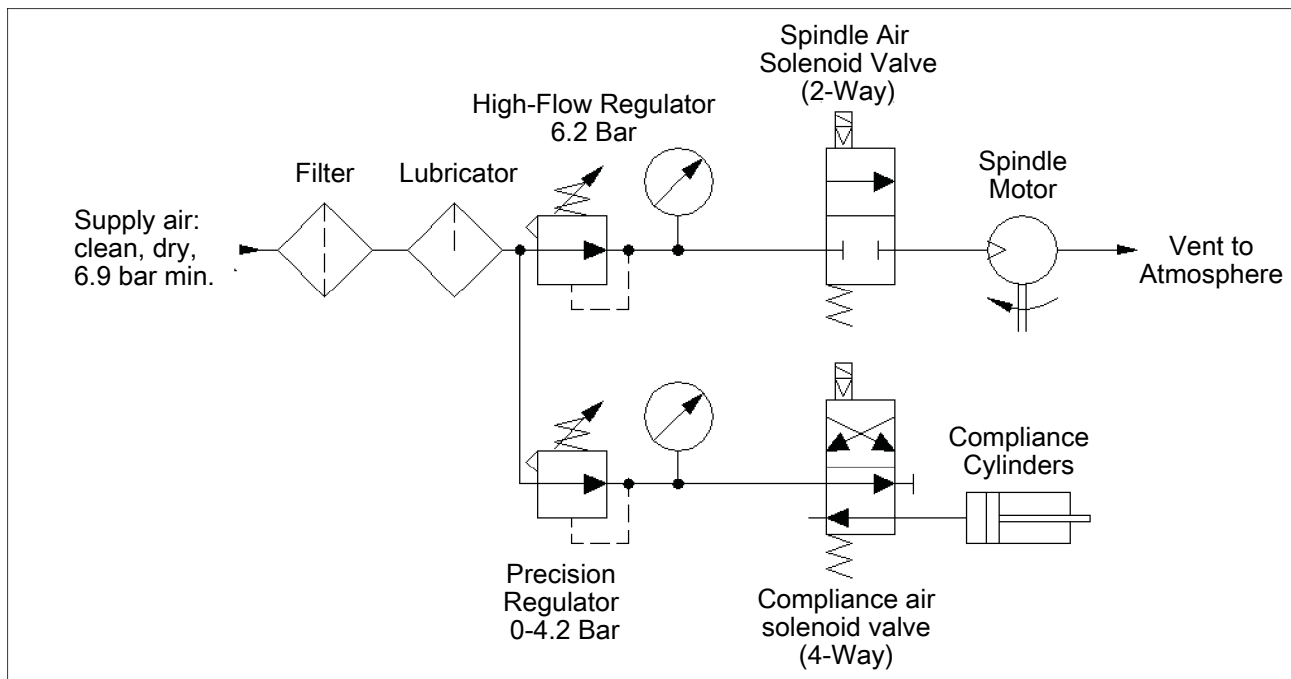

Pneumatic Connections

The air supply should be clean, dry, filtered, and optionally lubricated. ▶ 3 [11].

A high-flow air pressure control regulator is required to supply the spindle motor at 6.2 bar. A second, precision, self-relieving regulator will supply air for the compliance or centering force. The compliance force is applied axially and is adjusted until the desired finishing result is achieved. The robot traversing speed will also be adjusted to achieve the desired finish.

Conventional, customer-supplied, pneumatic components are used to control the air supply to the tool. SCHUNK recommends that the user install a high-flow pneumatic pressure regulator and a high-flow valve to properly supply a stable air supply of 6.2 bar to the spindle motor. (See Section ▶ 3 [11] for the maximum flow requirements.) While the spindle motor can be operated below 6.2 bar, it will not develop full power or speed. Very little airflow is required for the compliance mechanism. The air supply solenoid valve must be controlled through robot or controller.

NOTICE

Pneumatic components used for the motor drive circuit must be capable of meeting the air consumption requirements ▶ 3 [11]. Poor performance will result if the correct components are not used. Lubricators must be located as close to the unit as possible with performance rapidly deteriorating when the distance exceeds 5 meters.

Function	Connection Type	Pressure
Motor Inlet	G 1/4"	6.2 bar
Compliance (Axial) Force	G 1/8"	0.34–4.1 bar (max.)
Exhaust	G 1/4"(High-flow Muffler Supplied)	Not Applicable

The Radially flexible grinding, polishing and brushing spindle MFT must be plumbed using flexible tubing. The inside diameter of the tubing should be as large as practical to minimize pressure drop to the spindle motor [10mm minimum].

The air motor runs quiet and vents dry exhaust air to the environment through the pre-mounted silencer on the rear of the unit when using oil-free air or a slightly oily exhaust air when operating with oiled air. The customer may choose to replace the muffler with tubing to carry exhaust away from the work area. Such tubing must be as large and flexible as possible to minimize pressure drops and allow unrestricted axial motion

respectively. To reduce the sound level in neighboring working areas, a customer-supplied barrier surrounding the installation may be installed (Plexiglas or Lexan is preferred ▶ 3 [11]).

The compliance force air supply pressure regulator should be adjusted between 0.34 – 4.1 bar. When testing for the proper contact force, start with a very low pressure and increase slowly until the desired process result is achieved.

5.3 Electrical Connections

The Radially flexible grinding, polishing and brushing spindle MFT tool can be equipped with up to three sensors to monitor spindle position and speed. These include the Forward, Retract, and Tachometer sensors. Each sensor is a PNP type proximity switch using three wire electrical hook-up.

The Forward and Tachometer sensors are a standard 8mm threaded body 3-pin type. These sensors each have a three-wire cable with open strands, which are led out of the back of the Radially flexible grinding, polishing and brushing spindle MFT. The Retract sensor is a flat proximity switch whose short cable is terminated with a male threaded 8mm connector. This connection may be extended using any industry standard 8 mm 3-pin cable.

The electrical connections for 3-pin proximity sensors are color-coded and adhere to industry-standards. The blue sensor wires are connected to 0V and the brown wires are connected to a positive voltage source between 10V and 30VDC. With the PNP sensors used on Radially flexible grinding, polishing and brushing spindle MFT, the black wire is the output signal, when the switch closes (turns on). Thus, the sensor "sources" power to the load or monitoring circuit.

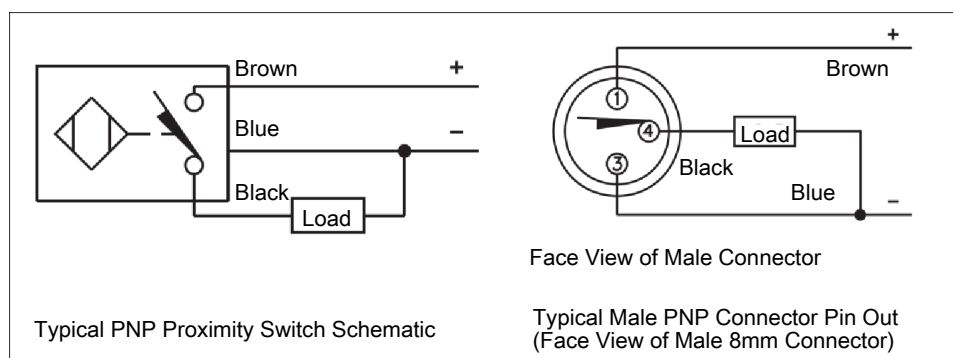

See ▶ 6 [21] of this manual for further information on setting and using these sensors.

5.4 Initial Operation

These operating instructions are intended to help system integrators program, start up, and complete an installation containing an axially compliant tool. The system integrator should be familiar with the task in general and should have extensive knowledge of programming and automation.

Important Note Regarding Operation:

The air motor is supported by two guide rods attached to the front plate of the deburring tool. To prevent binding of the compliance, one of these guide rods is rigidly attached to the front plate. The second guide rod and the compliance piston rods are free to float in the front plate. This allows the motor assembly to achieve free compliant motion while resisting the motor's torque.

DO NOT attempt to change the floating nature of the rods by adding washers or additional thread locker. These actions will prevent the rods from floating, which will result in binding of the tool's compliance.

5.4.1 Media Considerations

For instructions on how to replace the media, see ► [6.1 \[21\]](#)

In most applications, no cooling or lubrication of the part or tool is necessary nor is it desirable. For some materials and situations, the addition of coolants or compressed air may aid the cutting process. Any application of coolant must be exercised with care to prevent fluids from entering the tool or its chuck.

Select media and media holders that position the work piece as close to the Radially flexible grinding, polishing and brushing spindle MFT as possible.

5.4.2 Tool Position and Programming

The Radially flexible grinding, polishing and brushing spindle MFT dimensions are provided in the drawings in ► [8 \[29\]](#). The MFT provides axial compliance and performs best when the spindle is displaced through approximately one-half of its allowable travel (approximately 8 mm). The tool spindle must never be running while programming a machining center. During teaching, the compliance air must be on and supplied near 1.4 bar.

A simple programming method is to replace the desired media with a dowel pin which projects 8 mm less from the tool's chuck than the production media that will be used. The tip of this dowel can then be used to contact the part when teaching the robot path.

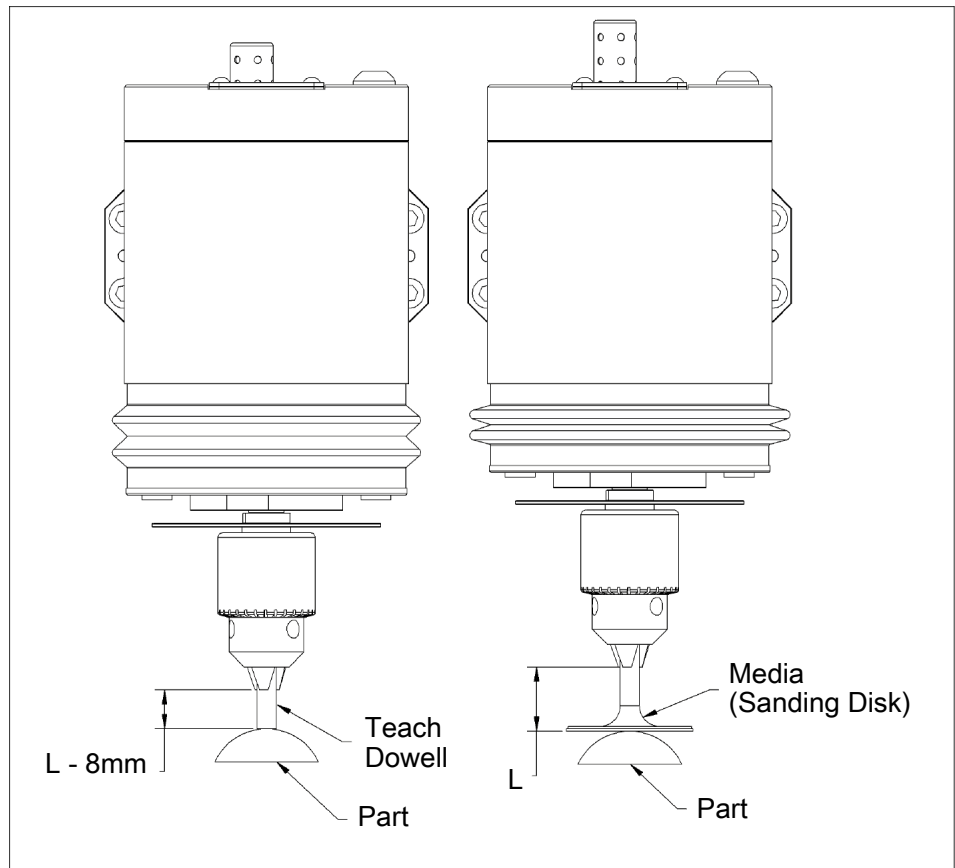

The short, teach dowel pin with the tool spindle fully extended (left in Figure) will simulate the position of the spindle deflected 8mm when the actual media/tool is installed (right in Figure). When running the program the first time, observe the path with the compliance air supply turned down to approximately 1.4 bar. Verify that at operational speed the media is deflected but contacts the work surface. Once the path has been confirmed, the compliance force of the media should be adjusted as described in ▶ 5.2 [16] in order to achieve the desired finish.

6 Maintenance and repair

Important Note Regarding Operation:

The air motor is supported by two guide rods attached to the front plate of the deburring tool. To prevent binding of the compliance, one of these guide rods is rigidly attached to the front plate. The second guide rod and the compliance piston rods are free to float in the front plate. This allows the motor assembly to achieve free compliant motion while resisting the motor's torque.

DO NOT attempt to change the floating nature of the rods by adding washers or additional thread locker. These actions will prevent the rods from floating, which will result in binding of the tool's compliance.

6.1 Routine Operational Maintenance

The tool utilizes a vane-type air motor with integral speed reduction gearbox. When subjected to normal use, the Radially flexible grinding, polishing and brushing spindle MFT will provide many hours of operation before service or repair is necessary. When subjected to high shock loading or periods of continuous service without interruption, the unit will require service or repair earlier. While simple in design, there are few user-serviceable parts in the assembly. The user is encouraged to return the unit to SCHUNK for service. The following information is provided to assist the user when they choose to service the unit in the field.

For all service, it is recommended that the air supply (before the solenoid valves) be disconnected. Drain any trapped air pressure in the lines. It is suggested that the air supply be "locked out" to prevent accidental operation of the spindle. During maintenance operations, refer to drawings in ▶ 8 [📄 29].

6.2 Media Replacement

The Radially flexible grinding, polishing and brushing spindle MFT unit ships with a simple drill chuck to hold customer-supplied media. A standard chuck key is used to loosen and tighten the chuck. Depending on the design, this can be a manual chuck or a key-operated chuck. The manual chuck is operated without tools and can be operated with both hands. When tightening the chuck, insert and turn the key into each of the three holes around the chuck's perimeter.

6.3 Boot Replacement

The tool is equipped with a simple boot between the moving motor mounting plate and the main housing. This boot is provided to minimize contamination of the guide and piston rods allowing free axial motion.



⚠ WARNING

This boot is not provided as a safety device

- Under no circumstances should the user operate the Radially flexible grinding, polishing and brushing spindle without the boot.
- The user should never have their hands on or near the Radially flexible grinding, polishing and brushing spindle when in operation.

Remove

1. Discharge any pressure in the air lines to the tool's spindle and compliance connections.
2. Use a suitable pick or small ball-end hex wrench to lift and remove the o-ring securing the boot to the front plate of the unit.
3. Similarly remove the o-ring securing the boot to the main housing.
4. Use the pick to lift the boot as necessary and slide it forward off the spindle end of the tool.

Install

1. Slip the first o-ring up and over the boss of the main housing, temporarily leaving the o-ring on the main housing.
2. Slip the boot over the moving motor mount plate and onto the main housing.
3. Position the boot so its locking surfaces engage the grooved boss on both the moving plate and the main housing.
4. Refit both o-rings to secure the boot.

6.4 Air Motor Replacement

The air motor can optionally be operated with clean, lubricated, filtered air. The motor includes a gearbox (gearhead) to lower the spindle speed. Maintenance of either the motor or the gearbox requires the motor be removed from the tool.

During the warranty period, the units with defective motors should be returned to SCHUNK for maintenance.

Should the customer wish to replace the motor after the warranty period, the following steps must be performed.

Remove

1. Discharge any pressure in the air lines to the tool's spindle and compliance connections.
2. Disconnect the flexible tubing supplying the air motor and compliance.
3. Disconnect any air lines connected to the motor's exhaust port in place of the muffler.
4. Thread G 1/4" straight fittings or pipe nipples into the motor's supply and exhaust ports to use as handles during the removal sequence.
5. Use the 15 mm open-end wrench to hold the spindle nut behind the chuck.
6. Insert the chuck key into the chuck. While holding the 15 mm wrench securely, unscrew the chuck counterclockwise using the chuck key as a lever.
7. With the chuck removed, hold the spindle threads with fingers and remove the 15 mm nut previously held by the open end wrench.
8. Use a hex wrench to loosen the four flat-head screws securing the seal plate to the moving motor mount plate at the front of the tool, thus freeing the air motor.
9. At the rear of the unit, grasp the fittings/nipples installed previously in the rear of the air motor and use them to rotate the motor **CLOCKWISE** from the rear. **NOTICE! The motor mount uses left-hand threads, rotate CLOCKWISE to remove..**
 ⇒ Auf diese Weise wird der Motor von der Frontplatte des Werkzeugs abgeschraubt.

Install

1. Reassembly is the reversal of these steps noting the following important steps.
2. Fit the seal plate to the moving motor mount plate tightening the flat-head screws until they bottom out.
3. Back the flat-head screws out one-half (1/2) turn.
4. Thread the motor into the front plate.
Remembering that the motor mount has left-hand threads and must be turned counterclockwise (from the rear) to tighten.
5. When the motor bottoms out against the seal plate, return to the flat-head screws on the seal plate and tighten them securely.
6. Apply a thin film of grease to the shoulder of the 15 mm nut that goes behind the chuck

7. Thread the 15 mm nut it onto the motor shaft until it bottoms out.
8. Thread the chuck onto the spindle until it bottoms out on the 15 mm nut.
9. As during removal, insert the chuck key into the chuck and use it as a lever to tighten the chuck against the 15 mm nut held by the open end wrench.
10. Reinstall the desired air supply fittings as appropriate.

6.5 Sensor Replacement

The Radially flexible grinding, polishing and brushing spindle MFT may be outfitted with up to three proximity sensors. These sensors may be monitored by the customer to determine the following information.

1. Monitoring –F: Forward Sensor. This sensor is included on all units. It is ON when the spindle is fully forward.
2. Monitoring –R: Retract Sensor. This sensor is ON when the spindle is fully Retracted.
3. Monitoring –T: Tachometer. This sensor delivers two OFF pulses for every spindle rotation.

These sensors for monitoring R and T can be added in the field.

6.5.1 Sensor for monitoring: Spindle extracted (Option-F)

The sensor is mounted inside the housing of the Radially flexible grinding, polishing and brushing spindle. When the spindle is fully extracted the sensor will turn on. The spindle must be displaced approximately 1mm to the rear before the sensor will turn off. This may be utilized to insure that the media is in contact with the part to be deburred.

Remove

1. Discharge any pressure in the air lines to the tool's spindle and compliance connections.
2. Remove the three socket head screws holding the rear housing to the front housing.
3. Remove the rear housing and observe the nickel plated cylindrical sensor mounted in the plastic block.
4. Remove the screw securing the plastic block to the housing and remove the sensor, pulling its lead through the rubber seal of the rear housing.

Install

1. Fit the plastic block to the housing and push the spindle fully forward.

2. Adjust the clearance between the face of the nickel plated sensor and the head of the socket head screw until the radial gap is approximately 1 mm.
3. Tighten the screw securing the block to the housing.
4. Pass the sensor wire out of the rear housing seal and refit the rear housing to the main housing of the tool. Insure that all o-ring seals are in place before securing the screws.
5. Connect the sensor wires to an appropriate power supply. (24V DC with blue = 0V, brown = +24V, and black = output).
6. Remove the stainless button head screw from the rear housing and reach through the opening with the appropriate sized hex wrench to turn the adjusting screw.
7. Push the motor mounting plate all the way forward.
8. With the spindle pushed all the way forward, turn the target socket head screw counter clockwise until the sensor just turns OFF.
9. Turn the target screw one complete turn clockwise.
10. Refit the stainless steel button head screw.

6.5.2 Sensor for monitoring: Spindle retracted (Option-R)

The sensor is mounted to the rear housing inside the tool. When the spindle is within approximately 1.5mm of being fully retracted the sensor will turn on. This may be utilized to indicate when excessive brush force is being applied (i.e., the brush has been pushed back so far and so hard that the end of compliance travel has been reached).

To remove, and install the sensor perform the following steps (there is no adjustment).

1. Discharge any pressure in the air lines to the tool's spindle and compliance connections
2. Remove the three socket head screws holding the rear housing to the front housing.
3. Locate the flat sensor secured to the rear housing using a single flat-head screw.
4. Remove the flat-head screw and pass the sensor and wire through the slot and rubber seal on the rear housing.
5. Reassembly is the reversal of these steps.

6.5.3 Sensor for rotation speed: Tachometer sensor (Option -T)

The tachometer sensor is an optional speed sensing system that allows the user to monitor the rotating speed of the spindle. A target disk is sandwiched between the spindle chuck and the nut

securing it. Two equally spaced holes in this plate serve as targets for the sensor. The sensor is mounted on the moving motor mount plate. For every rotation of the spindle there will be two OFF pulses to be monitored by the customer's tachometer circuit.

NOTE

The tachometer option is for process development. The thin target disk may be damaged in a production environment. Once process development is complete, the customer is advised to remove the target disk from the spindle or to insure that nothing can accidentally strike the target.

Remove

1. Discharge any pressure in the air lines to the tool's spindle and compliance connections.
2. Follow the instructions to remove the spindle chuck as described under ▶ 6.4 [📄 22]
3. Remove the boot as described under ▶ 6.3 [📄 22].
4. Remove the rear housing as described previously in the Forward and Retract Sensor sections.
5. At the front of the tool, loosen the jam nut securing the tachometer sensor to the moving motor mount plate.
6. Using the sensor's cable as a tool, rotate the cable counterclockwise to unscrew the sensor and withdraw it to the rear of the tool.

Install

1. Fit the cable to the sensor, insert it through the main housing and, using fingers (and the attached cable), thread it through the moving motor mount plate.
2. Fit the sensor jam nut and a single lock washer finger tight to the front of the moving motor plate.
3. Fit the large target plate to the motor spindle and fit the chuck. Tighten the chuck as described in ▶ 6.4 [📄 22].
4. Using fingers, advance the tachometer sensor until there is a gap of 1mm between the sensor and the back of the target plate. Rotate the spindle through one complete revolution by turning the chuck. Observe the sensor to target gap and adjust the sensor position as necessary so the sensor does not hit the target nor has a gap greater than 1mm. The target will have some warpage causing axial runout. This is normal and acceptable.
5. Tighten the sensor jam nut. **Do not use excessive torque on this nut.** Tighten the nut finger-tight followed by an additional 1/12 turn with a wrench.

6.6 Pneumatic –lines/–connections

The air tubing/lines to the MFT should routinely be checked for their general condition and replaced as required. The lines must be highly flexible to allow free axial motion of the tool.

The air to the tool must be filtered, dry, and lubricated. The air filters should be checked and replaced as required to maintain optimum performance. Check the oil level in the lubricator daily, adding oil as necessary. The life of the filter elements is dependent on the quality of compressed air at the customer's facility and therefore cannot be estimated.

6.7 Lubrication of the polishing spindle

The air motor must be supplied with clean, dry, filtered, lubricated air.

The air supply should be dry, filtered, and lubricated. A coalescing filter with elements rated for 5 micron or better is recommended. Air tool oil must be applied at a rate of 0.1 ml per 1000 liters of air. When an oil-fog type lubricator is utilized, this will equate to approximately 3–4 drops per minute at the rated air consumption of 8.3 liters/second. It is imperative that the lubricator be located less than 5.0 meters of the tool.

NOTICE

Failure to lubricate the air to the **vane motor** will result in premature failure of the motor and is not covered under warranty. It is recommended that the customer use a coalescing filter and filter elements rated 5 micron or better to remove trace moisture. A lubricator should be located less than 5.0 meters of the tool.

6.8 Storage and Preventive Maintenance during Storage

For short-term storage, the tool should be stored in a dry place in its crate when it is not in use.

For long-term storage, the Radially flexible grinding, polishing and brushing spindle MFT should be thoroughly cleaned of any burrs, dust, or debris.

To protect the air motor, the user may wish to inject several drops of oil directly into the motor input followed by a short burst of supply air to insure the vanes and internal components are completely lubricated.

The Radially flexible grinding, polishing and brushing spindle MFT should not be disassembled. Place the tool inside a sealed, plastic bag and place the bagged tool inside the crate.

7 Troubleshooting

7.1 Troubleshooting Matrix

Process development is an iterative, learning task. The following table is presented to assist in solving various problems.

Problem	Cause	Solution
Wear	Advance too high	Decrease width of cut/make multiple passes
	Feed rate is too slow	Increase feed rate
Unequal compliance	Defective regulator	Replace regulator
Poor finish	Feed rate is too fast	Reduce feed rate
	Tool is worn	Replace tool
Secondary burrs	Feed too high	Reduce feed rate
	Advance too high	Decrease width of cut/make multiple passes
	Incorrect feed direction	Change path
Spindle stalls	Not enough or no drive air	Check drive air regulator for 6.2 bar and for leaks
	Tool is not secure in collet	Properly tighten chuck
	Pressure force too high	Decrease width of cut/make multiple passes
	Compliance exceeded	Examine/correct path Decrease air pressure for compensation
Sticking spindle	Guide rods and pistons contaminated	Decrease air pressure for compensation

8 Drawings

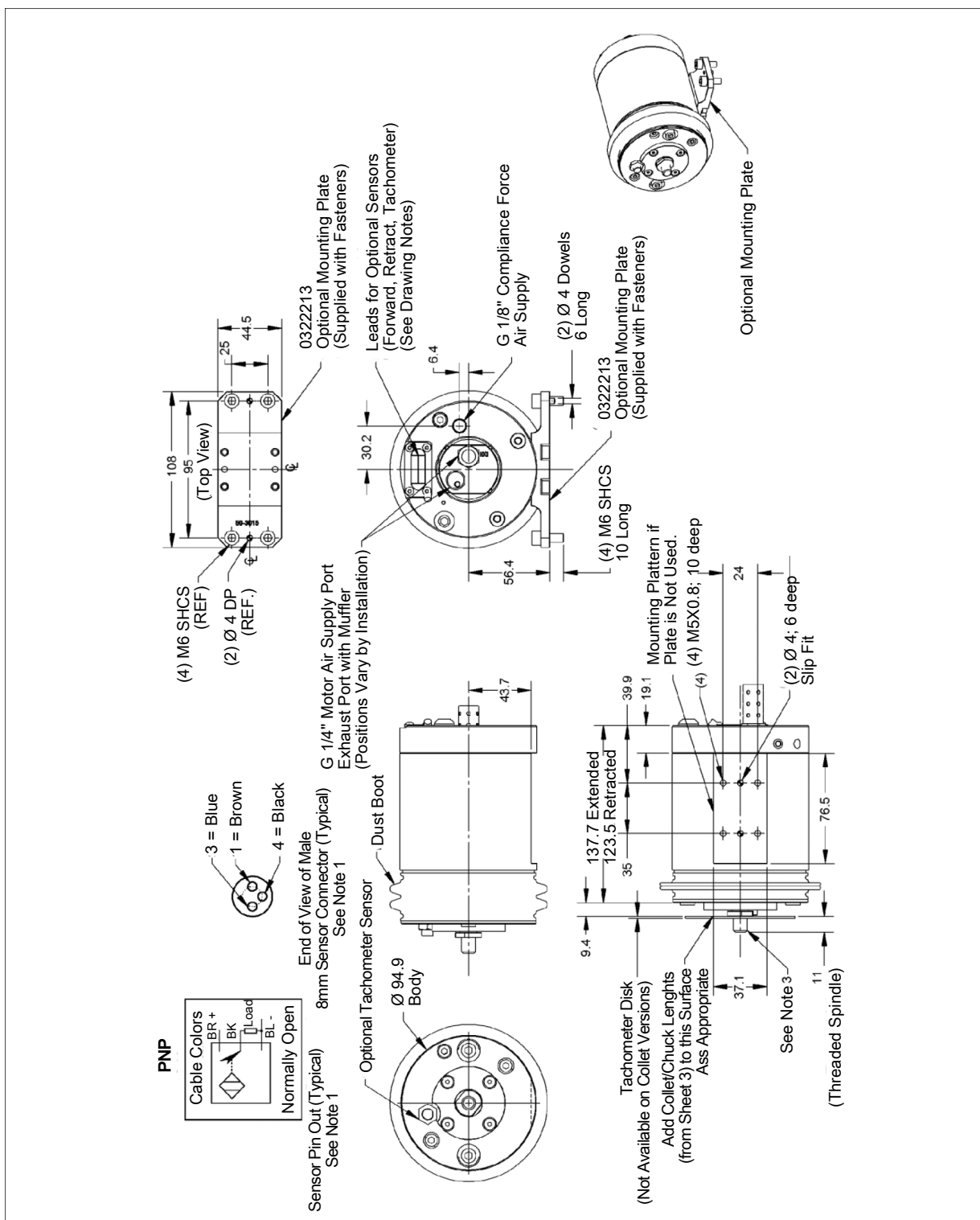

Option F - Sensor for monitoring: Spindle extracted

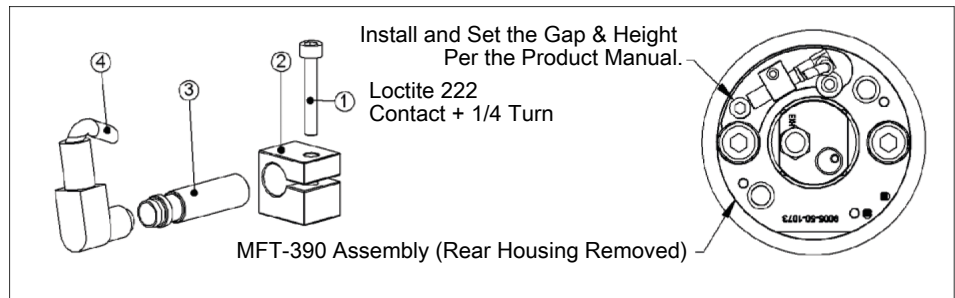

Designation	Ident number
MFT-390-OPTION F	0322260

NOTE

The sensor is "ON" when the spindle is fully forward and not contacting the workpiece.

Option T - Tachometer Sensor option

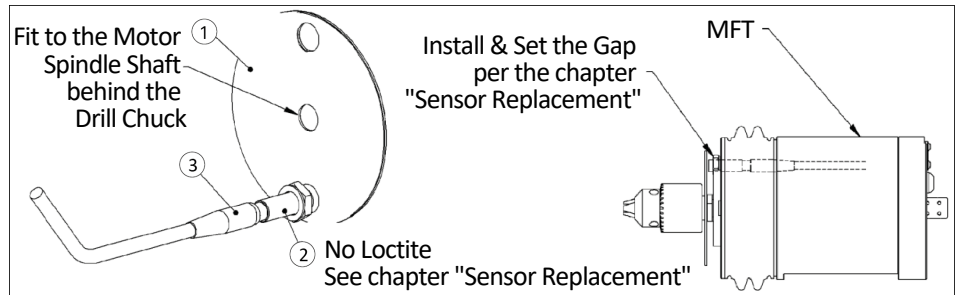

Designation	Ident number
MFT-390 OPTION T	0322261

NOTE

- Not Available on Models with Collet Bodies
- The tachometer sensor delivers "OFF" pulses per revolution to be monitored by the customer's process equipment. The tachometer is a process development tool and it is not recommended for production environments where the target disk may be damaged by collisions and impacts.

Option R - optional sensor for monitoring: Spindle retracted

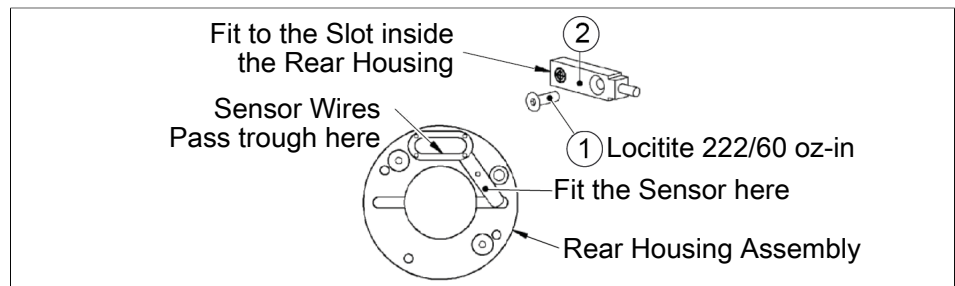

Designation

MFT-390-OPTION R

Ident number

0322262

NOTE

The retract sensor is "ON" when the spindle is fully backward (Pushed backwards to the limit of travel).

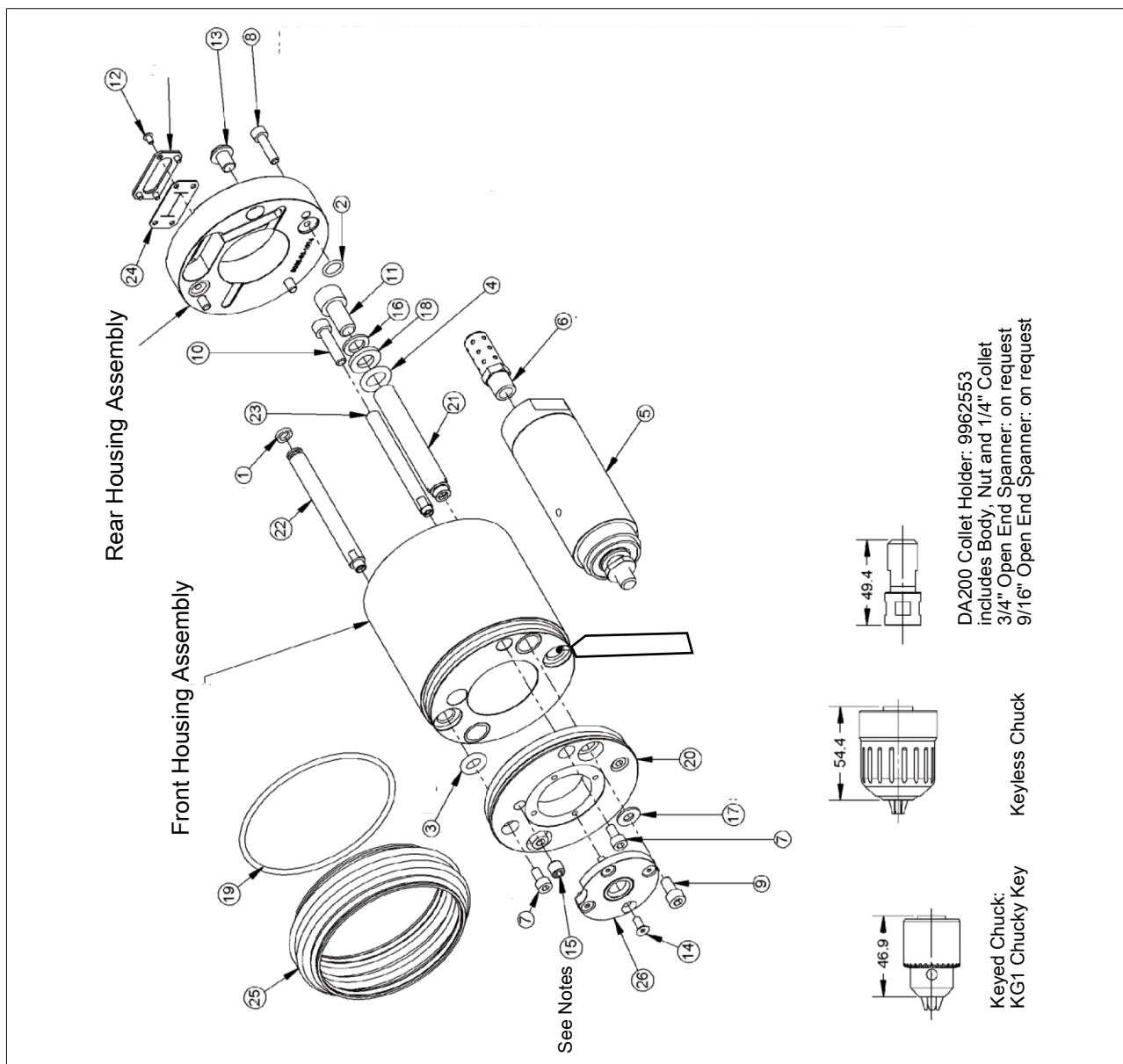

NOTE

- Fasteners on this drawing include both torque and thread locker specifications. Thread locker (Loctite) is not required when using new "blue" fasteners purchased from SCHUNK. Thread locker is required anytime fasteners are being re-used.
 - M8 Set Screw is used if no tachometer kit is installed. Apply Loctite-222 to set screw and install flush with metal plate.
-

9 Translation of the original declaration of incorporation

in terms of the Directive 2006/42/EG, Annex II, Part 1 Section B.

Manufacturer/
Distributor SCHUNK SE & Co. KG
Spanntechnik | Greiftechnik | Automatisierungstechnik
Bahnhofstr. 106 – 134
D-74348 Lauffen/Neckar

We hereby declare that the partly completed machine described below

Product designation: Radially flexible grinding, polishing and brushing spindle / MFT /
ID number 0322250, 0322251, 0322252, 0322253, 30071281, 30072156, 30074216

meets the following basic occupational health and safety of the Machinery Directive 2006/42/EC:

No. 1.1.1, No. 1.1.2, No. 1.1.3, No. 1.1.5, No. 1.3.2, No. 1.5.3, No. 1.5.4, No. 1.5.6, No. 1.5.8, No. 1.5.10, No. 1.5.11, No. 1.5.13

The partly completed machinery may not be put into operation until it has been confirmed that the machine into which the partly completed machinery is to be installed complies with the provisions of the Machinery Directive (2006/42/EC). The declaration shall be rendered invalid if modifications are made to the product.

The special technical documentation according to Annex VII, Part B, belonging to the partly completed machine, has been created.

Person authorized to compile the technical documentation:
Stefanie Walter, Address: see manufacturer's address

Signature: see original declaration

Lauffen/Neckar, February 2025

Dr.-Ing. Manuel Baumeister,
Head of Systems Engineering,
Technology & Innovation

11 Information on the RoHS Directive, REACH Regulation and Substances of Very High Concern (SVHC)

RoHS Directive

SCHUNK products are classified as "large-scale stationary installations" or as "large-scale stationary industrial tools" within the meaning of Directive 2011/65/EU and its extension 2015/863/EU "on the restriction of the use of certain hazardous substances in electrical and electronic equipment (RoHS)", or fulfill their intended function only as part of one. Therefore products from SCHUNK do not fall within the scope of the directive at this time.

REACH Regulation

Products from SCHUNK fully comply with the regulations of Regulation (EC) No. 1907/2006 "concerning the Registration, Evaluation, Authorization and Restriction of Chemicals (REACH)" and its amendment 2022/477. SCHUNK attaches great importance to completely avoiding chemicals of concern to humans and the environment wherever possible.

Only in rare exceptional cases do SCHUNK products contain SVHC substances on the candidate list with a mass content above 0.1%. In accordance with Article. 33 (1) of Regulation (EC) No. 1907/2006, SCHUNK complies with its duty to "communicate information on substances in articles" and lists the components concerned and the substances used in an overview that can be viewed at schunk.com/SVHC.

Signature: see original declaration

Lauffen/Neckar, February 2025

Dr.-Ing. Manuel Baumeister,
Head of Systems Engineering,
Technology & Innovation



SCHUNK SE & Co. KG
Spanntechnik | Greiftechnik | Automatisierungstechnik

Bahnhofstr. 106 - 134
D-74348 Lauffen/Neckar
Tel. +49-7133-103-0
info@de.schunk.com
schunk.com

Folgen Sie uns | *Follow us*



Wir drucken nachhaltig | *We print sustainable*