



## Power lathe chuck

### ROTA 2B

Assembly and operating manual

## Imprint

### Copyright:

This manual is protected by copyright. The author is SCHUNK SE & Co. KG.  
All rights reserved.

### Technical changes:

We reserve the right to make alterations for the purpose of technical improvement.

**Document number:** 0889059

**Version:** 04.00 | 21/10/2025 | en

Dear Customer,

Thank you for trusting our products and our family-owned company, the leading technology supplier of robots and production machines.

Our team is always available to answer any questions on this product and other solutions. Ask us questions and challenge us. We will find a solution!

Best regards,

Your SCHUNK team

Customer Management

Tel. +49-7572-7614-1300

Fax +49-7572-7614-1039

cmm@de.schunk.com



**Please read the operating manual in full and keep it close to the product.**

## Table of Contents

<b>1 General .....</b>	<b>5</b>
1.1 About this manual.....	5
1.1.1 Illustration of warnings .....	5
1.1.2 Applicable documents .....	6
1.2 Warranty .....	6
1.3 Scope of Delivery.....	6
<b>2 Basic safety notes.....</b>	<b>7</b>
2.1 Appropriate use .....	7
2.2 Inappropriate use .....	7
2.3 Structural changes.....	8
2.4 Spare parts .....	8
2.5 Ambient conditions and operating conditions .....	8
2.6 Material limitations .....	8
2.7 Chuck Jaws .....	9
2.8 Personnel qualifications .....	9
2.9 Personal protective equipment .....	10
2.10 Transport.....	10
2.11 Protection during handling and assembly .....	10
2.12 Protection during commissioning and operation .....	10
2.13 Notes on safe operation.....	10
2.14 Disposal .....	13
2.15 Fundamental dangers .....	13
2.16 Protection against dangerous movements .....	13
2.17 Notes on particular risks .....	13
<b>3 Technical data .....</b>	<b>16</b>
3.1 Chuck data .....	16
3.2 Clamping force / speed diagrams .....	17
3.3 Calculations for clamping force and speed .....	20
3.3.1 Calculation of the required clamping force in case of a given rpm.....	21
3.3.2 Calculation example: required initial clamping force for a given speed ..	23
3.3.3 Calculation of the permissible speed in case of a given initial clamping force .....	24
3.4 Grades of Accuracy .....	24
3.5 Permissible imbalance DIN ISO 21940-11 .....	24
<b>4 Function .....</b>	<b>25</b>
4.1 Function and handling.....	25
4.2 Replacement or renewal of jaws.....	25

<b>5 Mounting</b> .....	<b>26</b>
5.1 Torques per screw .....	26
5.2 Mounting in general .....	26
5.2.1 Pre-assembly measures .....	26
5.2.2 Chuck assembly options .....	27
5.3 Mounting of the Chuck to the Machine Spindle .....	28
5.4 Mounting chuck on Opus B cylinder .....	31
5.5 ROTA 2B S – KONTEC (125 – 315) .....	32
<b>6 Maintenance</b> .....	<b>33</b>
6.1 Lubrication .....	33
6.2 Lubricating position .....	33
6.3 Maintenance and lubrication plan .....	33
6.4 Central oil lubrication .....	34
6.5 Disassembly and assembly of the Chuck .....	34
6.6 Changing the stepped jaws .....	35
<b>7 Storage</b> .....	<b>36</b>
<b>8 Part lists</b> .....	<b>37</b>
<b>9 Section and exploded drawing</b> .....	<b>38</b>
<b>10 Manufacturer certificate</b> .....	<b>39</b>

# 1 General

## 1.1 About this manual

This manual contains important information for the safe, correct use of the product.

It is an integral part of the product and must be kept accessible for personnel at all times.

Personnel must have read and understood this manual before beginning any work. The observance of all safety notes in this manual is a prerequisite to ensure safe work processes.

The illustrations are intended to provide a basic understanding and may deviate from the actual version.

Besides this manual, other documents which apply are those listed under ▶ 1.1.2 [ 6 ]

### 1.1.1 Illustration of warnings

To make risks clear, the following signal words and symbols are used for safety notes.



#### **⚠ DANGER**

Denotes a hazard with a high degree of risk that, if not avoided, will result in death or serious injury.



#### **⚠ WARNING**

Denotes a hazard with a medium degree of risk that, if not avoided, could result in death or serious injury.



#### **⚠ CAUTION**

Denotes a hazard with a low degree of risk that, if not avoided, could result in a minor or moderate injury.

#### **NOTICE**

Information about avoiding material damage.

### 1.1.2 Applicable documents

- General Terms and Conditions \*
- Calculation of the jaw centrifugal forces and jaw guidance load, in the "Technology" chapter of the lathe chuck catalog \* and the "Calculating the clamping force and RPM" chapter
- Brief operating instructions if available
- Approval drawings

The documents labeled with an asterisk (\*) can be downloaded from **schunk.com**.

## 1.2 Warranty

The warranty for standard products is 24 months from the date of delivery from the factory, or 50,000 cycles\* for manually operated clamping devices and 500,000 cycles\* for power operated clamping devices. For special clamping devices, it is 12 months from the date of delivery from the factory, assuming appropriate use in accordance with the following conditions:

- Observe the applicable documents, ▶ 1.1.2 [ 6 ]
- Observance of the ambient conditions and operating conditions, ▶ 2.5 [ 8 ]
- Observance of the specified maintenance and lubrication intervals ▶ 6.3 [ 33 ]

Parts touching the workpiece and wearing parts are not part of the warranty.

\* One cycle comprises one complete clamping procedure ("opening" and "closing")

## 1.3 Scope of Delivery

The scope of delivery includes

- 2 Jaw Power Chuck incl. 4 fastening screws for base jaws with fine serration
- 4 T-nuts with screws for base jaws with tongue and groove
- 2 screws (12.9)

## 2 Basic safety notes

Improper handling, assembly and maintenance of this product may result in risk to persons and equipment if this operating manual is not observed.

### 2.1 Appropriate use

- The product is used for clamping metal and plastic workpieces on machine tools.
- The product may only be used within the scope of its technical data.
- The product is intended for industrial and commercial use.
- Appropriate use of the product includes compliance with all instructions in this manual.
- The maximum speed and the necessary clamping force must be determined by the operator for each clamping task in accordance with the valid standards or technical specifications of the manufacturer.  
(See also "Calculation for clamping force and speed of rotation" in the chapter "Technical data").
- Use suitable top jaws with a suitable interface.
- The interference circuit diameter of the workpiece must be smaller or at most equal to the outer diameter of the clamping device.
- The workpiece must not experience plastic deformation under clamping force (clamping pressures are permissible).

### 2.2 Inappropriate use

The product is not being used appropriately if:

- the product is used as a press, a punch, a toolholder, a load-handling device or as lifting equipment.
- the specified technical data for use of the product are exceeded.
- workpieces are not properly clamped, paying particular attention to the specified clamping forces.
- the top jaws are not mounted properly.
- the product is not being operated properly.
- the product is operated in the stroke end positions.
- the guideways are overloaded due to the chuck jaws being too high or the clamping point being selected too high.
- the product has been insufficiently maintained.
- the product is brought into contact with aggressive media, especially acids.
- the product is used in abrasive blasting processes, especially sandblasting.
- the product is operated in a potentially explosive area (EX area (ATEX directive)).

## 2.3 Structural changes

### Implementation of structural changes

Modifications, changes or reworking, e.g. additional threads, holes, or safety devices, can damage the product or impair its functionality or safety.

- Structural changes should only be made with the written approval of SCHUNK.

## 2.4 Spare parts

### Use of unauthorized spare parts

Using unauthorized spare parts can endanger personnel and damage the product or cause it to malfunction.

- Only use original spare parts and spares authorized by SCHUNK.

## 2.5 Ambient conditions and operating conditions

### Required ambient conditions and operating conditions

Incorrect ambient and operating conditions can make the product unsafe, leading to the risk of serious injuries, considerable material damage and/or a significant reduction in the service life of the product.

- Make sure that the product is only used within its defined application parameters.
- Ensure that the product is of a sufficient size for the application.
- Ensure that maintenance and lubricating intervals are observed.
- Only use cooling emulsions with anti-corrosive additives when machining.

Depending on the operating conditions, the function and clamping force must be checked after a certain period of operation.

With the smallest possible actuation pressure on the clamping cylinder, the base jaws should move evenly. This method is not a substitute for measuring the clamping force.

If the clamping force has dropped too much or if the base jaws and/or the release mechanism no longer move properly, the clamping device must be disassembled, cleaned, and relubricated.

## 2.6 Material limitations

The product is made of steel alloys, elastomers, aluminum alloys and brass. In addition, Linomax plus grease, Branotect anti-rust oil and Renolit HLT2 are incorporated into the product as auxiliary and operating materials. The safety data sheet for LINOMAX plus can be found at [www.schunk.com](http://www.schunk.com).

## 2.7 Chuck Jaws

### Requirements of the chuck jaws

Rotational or if applicable, accumulated energy, can make the product unsafe and risk the danger of serious injuries and considerable material damage.

- Change chuck jaws at a standstill and without a clamped workpiece.
- Do not use welded jaws.
- Design the chuck jaws to be as light and as low as possible. The clamping point must be as close as possible to the chuck face (clamping points at a greater distance lead to greater surface pressure in the jaw guidance and can significantly reduce the clamping force).
- If the clamping point is at a greater distance from the housing, the operating pressure must be reduced.
- After a collision, the clamping device and the chuck jaws must be subjected to a crack detection test before being used again. Replace damaged parts with original SCHUNK spare parts.
- The chuck jaw mounting screws and if present, the T-nuts, must be replaced if there are signs of wear or damage. Only use screws of quality grade 12.9 in compliance with the specified tightening torques. For clamping devices with fine serration, the jaw mounting screws must be screwed into the holes closest to the clamping point.

## 2.8 Personnel qualifications

### Inadequate qualification of personnel

Any work on the product by inadequately qualified personnel can lead to serious injuries and considerable material damage.

- All work must be performed by appropriately qualified personnel.
- Personnel must have read and understood the complete manual before beginning any work on the product.
- Observe country-specific accident prevention regulations and the general safety notes.

The following personnel qualifications are required for the various activities on the product:

#### Qualified electrician

Qualified electricians have the professional training, knowledge, and experience to work on electrical systems, to recognize and avoid potential dangers, and know the relevant standards and regulations.

#### Specialist personnel

Specialist personnel have the specialized training, knowledge, and experience to perform the tasks entrusted to them, to recognize and avoid potential dangers, and know the relevant standards and regulations.

**Instructed person** Instructed persons have been instructed by the operator regarding the tasks entrusted to them and the potential dangers of inappropriate behavior.

**Manufacturer's service personnel** The manufacturer's service personnel have the specialized training, knowledge, and experience to perform the work entrusted to them and to recognize and avoid potential dangers.

## 2.9 Personal protective equipment

### Use of personal protective equipment

Personal protective equipment serves to protect staff in the event of a danger that may interfere with their health or safety at work.

## 2.10 Transport

### Handling during transport

Incorrect handling during transport can make the product unsafe and risks the danger of serious injuries and considerable material damage.

- During transport and handling, secure the product to prevent it from falling.
- Use the transport thread on the clamping device.

## 2.11 Protection during handling and assembly

### Incorrect handling and assembly

Incorrect handling and assembly can make the product unsafe and can risk the danger of serious injuries and considerable material damage.

- All work must only be performed by appropriately qualified personnel.
- Secure the system against accidental operation during all work.
- Use suitable assembly and transport equipment and take precautions to prevent jamming and crushing.

## 2.12 Protection during commissioning and operation

### Falling or violently ejected components

Falling and ejected components can lead to serious injury or death.

- Take suitable protective measures to secure the danger zone.

## 2.13 Notes on safe operation

### Incorrect manner of working by personnel

An incorrect manner of working can make the product unsafe and risks serious injuries and considerable material damage.

- Observe the safety notes and assembly instructions.
- Do not expose the product to any corrosive media. Products for special ambient conditions are excluded.

- Rectify malfunctions as soon as they occur.
- Observe the care and maintenance instructions.
- Observe the current safety, accident prevention, and environmental protection regulations for the application field of the product.
- The chuck may only be accelerated to speed or otherwise when a workpiece is correctly clamped. This means that the clamping force has been applied to the workpiece and the clamping has taken place within the permissible operating range.
- Unclamping may only occur once the machine spindle has come to a standstill.

### Functionality check

After installation of the clamping device, its function must be checked prior to commissioning.

#### Two important points are:

- **Clamping force:** At max. actuation force/pressure/torque, the clamping force specified for the clamping device must be reached.
- **Stroke control:** The stroke of the clamping piston must have a margin of safety at the front and back end positions. The machine spindle must not start up until the clamping piston has passed through this safety margin.

With manual clamping devices, stroke control is carried out via the indicator pin. Clamping is only correct if the indicator pin is countersunk and clamping force is applied to the workpiece.

When determining the clamping force required to machine a workpiece, the centrifugal force acting on the chuck jaws must be taken into account (according to VDI 3106).

### Maintenance instructions

The clamping device's reliability and safety can only be guaranteed if the operator complies with the manufacturer's maintenance instructions.

- For lubrication, we recommend our tried and tested special grease, LINOMAX plus. Unsuitable lubricants can have a negative impact on the functioning of the clamping device (clamping force, coefficient of friction, wear behavior). (For product information about LINOMAX plus, see the "Accessories" chapter of the SCHUNK lathe chuck catalog or contact SCHUNK.)
- Use a suitable high-pressure grease gun to ensure that you reach all the greasing areas.
- To ensure correct distribution of the grease, move the clamping device to its end positions several times, lubricate again, and then check the clamping force.
- Move the clamping device through to its end position several times after 500 clamping strokes, at the latest. This moves the lubricant back to the surfaces of the force transmission.
- Check the clamping device regularly for clamping force and jaw stroke.

### Clamping force measurement

- Depending on the operating conditions, the function and clamping force must be checked after a certain period of operation. For this purpose, a calibrated clamping force meter (e.g. SCHUNK IFT) must be used. The loading conditions are shown below for the different chuck variants.

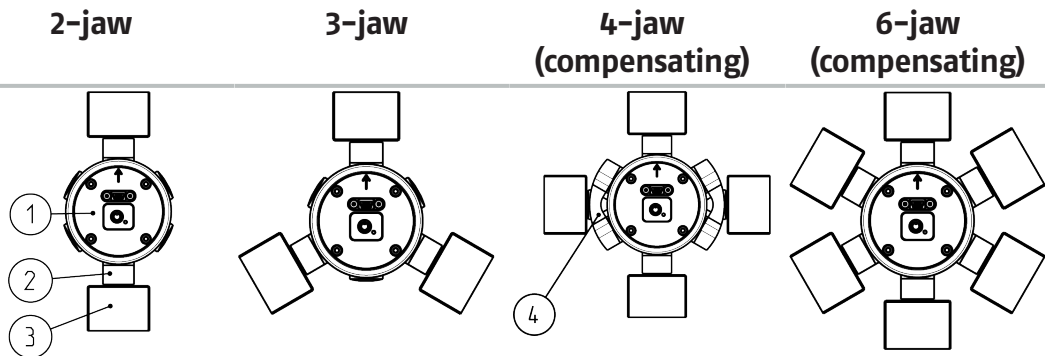

	2-jaw	3-jaw	4-jaw (compensating)	6-jaw (compensating)
<b>Measuring device</b>	SCHUNK IFT clamping force tester	SCHUNK IFT clamping force tester	SCHUNK IFT clamping force tester	SCHUNK IFT clamping force tester
<b>Accessories</b>	-	-	IFT MA4	-
<b>Measuring points</b>	0°/180°	0°/120°/240°	0° / 180° / 90° / 270° (IFT MA4)	0°/60°/120°/180°/240°/300°
<b>Please note</b>	Operating manual SCHUNK IFT Clamping force tester	Operating manual SCHUNK IFT Clamping force tester	Operating manual SCHUNK IFT Clamping force tester	Operating manual SCHUNK IFT Clamping force tester
			<b>Attention</b> Compensation must be activated, otherwise it may lead to inconsistent results.	<b>Attention</b> Compensation must be activated, otherwise it may lead to inconsistent results.

- ① Measuring head
- ② Clamping insert
- ③ Chuck jaw
- ④ Bridge element (IFT MA4)

- If the clamping force has dropped too much or if the base jaws and piston no longer move properly, the chuck will have to be disassembled, cleaned and relubricated.
- The clamping force should always be measured with the clamping device in the same condition as it is used in for the current clamping application. If top jaws with clamping steps are used, measuring must be performed in the same step as for the respective clamping task. In the event of high operating speeds, clamping force losses must be accounted for due to the centrifugal force acting on the chuck jaws. In this case the value of the operating clamping force should be measured dynamically.
- We recommend checking the clamping force using a clamping force tester before starting a new production run and between maintenance intervals. "Optimum safety can only be guaranteed through regular checks".

## 2.14 Disposal

### Handling of disposal

Incorrect handling of disposal can make the product unsafe and lead to risks of environmental harm.

- Follow local regulations on dispatching product components for recycling or proper disposal.

## 2.15 Fundamental dangers

### General

- Disconnect power sources before installation, modification or calibration. Ensure that no residual energy remains in the system.
- Do not reach into the open mechanism or movement area of the product during operation.

## 2.16 Protection against dangerous movements

### Unexpected movements

If the system still retains residual energy, serious injuries can be caused while working on the product.

- Switch off the energy supply, ensure that no residual energy remains and secure against inadvertent reactivation.
- Never rely merely on the response of the monitoring function to avert danger. Assume that the drive movement is faulty as long as the installed monitors are not effective, since the effect depends on the control and the current operating state of the drive.
- To avoid accidents and/or material damage, human access to the movement range of the machine must be restricted.

## 2.17 Notes on particular risks



### **⚠ DANGER**

**Risk of fatal injury to operating personnel due to the workpiece falling down or being flung out in the event of a power failure**

This poses a risk of death or injury to the operating personnel and can result in serious damage to the machine.



### **⚠ DANGER**

**Possible risk of death for the operating personnel in case of insufficient clamping force due to ejection or falling of the workpiece!**

Due to settling behavior, the clamping force may decrease over time.

- Re-clamping of the workpiece with manual or pneumatic clamping devices after 4 hours.
- The energy supply must be constantly applied to power-operated clamping devices during operation.
- Use clamping cylinders with energy conservation.



**⚠ DANGER**

**Possible risk of death for operating personnel if the clamping device's top speed of rotation is exceeded and a workpiece is released or parts fly off.**

If the machine tool or the technical equipment can reach a higher speed than the maximum speed of the clamping device, the speed must be limited for safety purposes!



**⚠ DANGER**

**Possible risk of death for operating personnel if a jaw breaks or if the clamping device fails because the technical data has been exceeded and a workpiece is released or parts fly off!**

- Never exceed the technical data specified by the manufacturer for using the clamping device.



**⚠ DANGER**

**Possible risk of death for operating personnel from clothing or hair getting caught on the clamping device and being dragged into the machine!**

Loose clothing or long hair may become caught on projecting parts of the clamping device and be drawn into the machine.

- Always wear tight-fitting clothing and a hairnet when working on the machine and the lathe chuck.



**⚠ WARNING**

**Possible risk of death for the operating personnel due to impact of the rotating clamping device!**

- Keep a safe distance to the rotating clamping device!
- Do not reach into the rotating clamping device!



**⚠ CAUTION**

**Risk of limbs being crushed when opening and closing the chuck jaws during manual loading or unloading or when exchanging moving parts.**

- Do not reach between the chuck jaws.



### ⚠ CAUTION

#### **Hazard from vibration due to imbalanced rotating parts and noise generation.**

Physical and mental strains due to imbalanced workpieces and noise during the machining process on the clamped and rotating workpiece.

- Ensure the clamping device's axial and concentric runout.
- Check options for remedying imbalances on special top jaws and workpieces.
- Reduce the speed.
- Wear hearing protection.



### ⚠ CAUTION

#### **There is a risk of limbs being crushed by moving parts during manual loading and unloading and the clamping procedure.**

- Do not reach between the chuck jaws.
- Use loading devices.



### ⚠ CAUTION

#### **Allergic reactions or irritation due to skin or eye contact with lubricants on the product.**

- In case of foreseeable contact with lubricants on the product (e.g. when lubricating or cleaning)
- Wear protective equipment (protective gloves, protective goggles)

### NOTICE

#### **Risk of damage due to incorrect choice of clamping position for chuck jaws on workpiece.**

If an incorrect clamping position is chosen for the chuck jaws on the workpiece, the base and top jaws may become damaged.

- Observe maximum positions of base and top jaws.
- The diameter of the workpiece must not be greater than the clamping device diameter.
- For clamping devices with fine serration, do not allow the T-nuts for connecting the top jaws to protrude beyond the base jaws in radial direction.
- The outer diameter of the screwed-on top jaws must not exceed the outer diameter of the clamping device by more than 10%.

### 3 Technical data

#### 3.1 Chuck data

ROTA 2B	125	160	200	250	315	400
Max. actuating force [kN]	23	32	45	61	68	68
Max. clamping force [kN]	26	40	54	75	85	85
Max. speed of rotation [RPM]	5300	4000	3200	2700	2200	2000
Stroke per jaw [mm]	10	12.5	15	16	18	18
Piston stroke [mm]	17.5	22	26	28	32	32
Weight [kg]	3.65	6.7	13	21.5	36	53
Mass moment of inertia [kgm <sup>2</sup> ]	0.0073	0.02	0.06	0.16	0.38	0.98
Centrifugal moment on the base jaw $M_{cGB}$ [kgm]						
• Fine serration	-	0.032	0.064	0.128	0.211	0.331
• Tongue and groove	0.018	0.035	0.072	0.156	0.196	0.430
Max. jaw center of gravity in axial direction $a_{max}$ [mm]						
• Fine serration	-	24	32	32	32	32
• Tongue and groove	20	24	24	32	32	40
Operating temperature [°C]			15 – 60			

#### Sizes 500 to 600 upon request

The recommended max. RPM is only valid for max. operating force and the use of the suitable hard standard stepped jaws.



#### **⚠ WARNING**

#### **Danger of personal injury and property damage caused by flying parts in case of spiral fracture of soft top jaws!**

Soft standard top jaws must be hardened at the area around the countersink.

**They should only be depth-hardened, not surfacehardened.**

If unhardened top jaws or special chuck jaws are used, ensure that the jaws weigh as little as possible. For soft top jaws or special chuck jaws, the permissible speed of rotation according to VDI 3106 must be calculated for the machining job in question. The recommended maximum speed must not be exceeded. The calculations must be checked using dynamic measurement. Function monitoring (piston movement and actuating pressure) must be performed in accordance with the guidelines of the Berufsgenossenschaft (employers' mutual insurance association).

### 3.2 Clamping force / speed diagrams

Clamping force-/RPM-diagrams were determined by using 2 chuck jaws. For this process, the maximum actuating force was applied. It is also assumed the chuck is in perfect condition and lubricated with SCHUNK LINOMAX plus special grease. If one or more of these prerequisites is altered, the diagrams will no longer be valid.

#### Chuck set-up for gripping force / speed diagram:

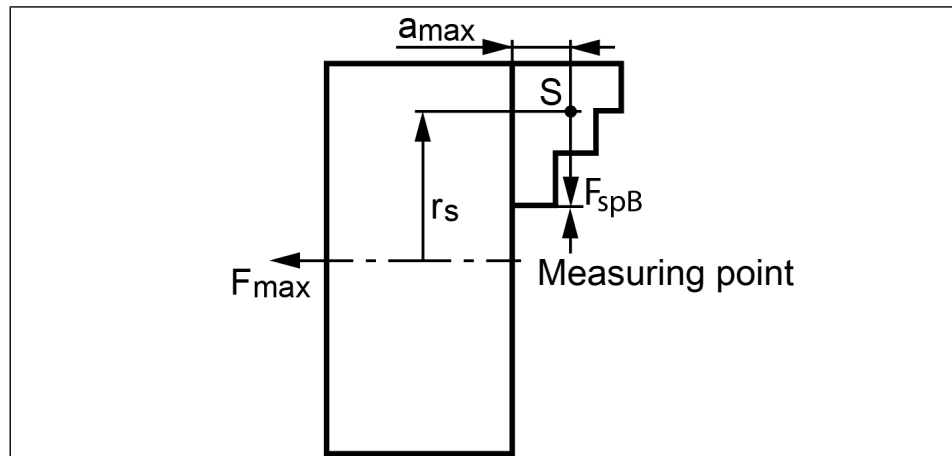

$F_{spB}$	Clamping force per jaw	S	Center of gravity
$r_s$	Center of gravity radius	$a_{max}$	Max. jaw center of gravity eccentricity in axial direction
$F_{max}$	Max. actuating force		

#### Clamping force / speed diagram ROTA 2B 125

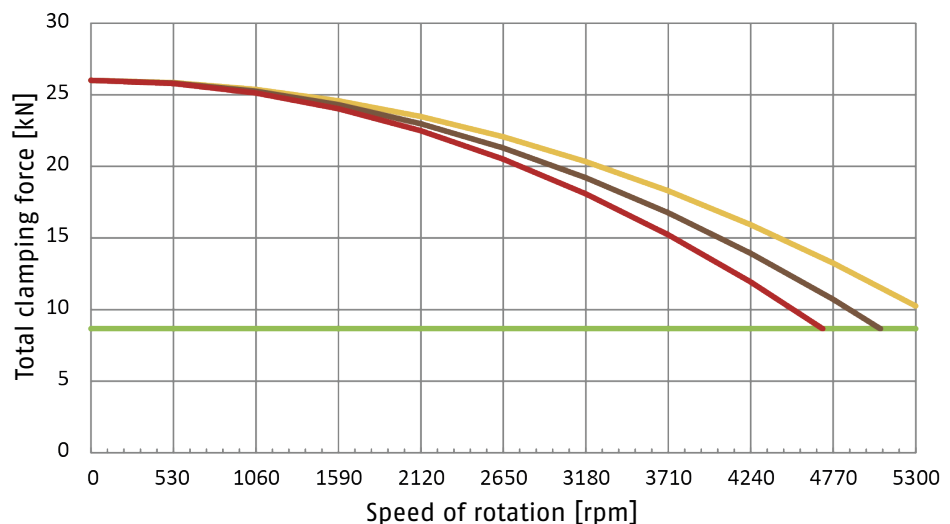

Colour	Jaw ID	Weight [kg]
Yellow	2 SWKK 125	0.8
Brown	2 SWKK 125	1.2
Red	2 SWKK 125	1.5
Green	Minimum required clamping force 33%	

### Clamping force / speed diagram ROTA 2B 160

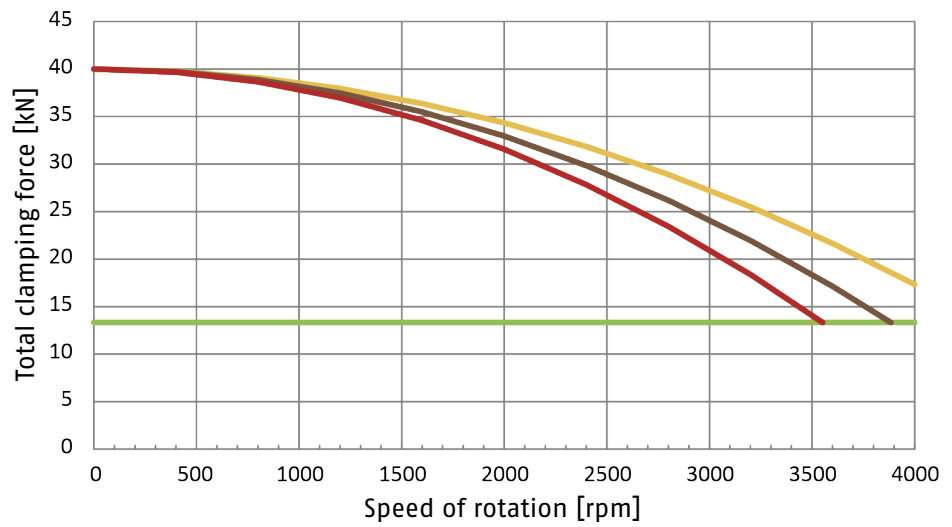

Colour	Jaw ID	Weight [kg]
	2 SWKK 160	1.1
	2 SWKK 160	1.4
	2 SWKK 160	3.1
	Minimum required clamping force 33%	



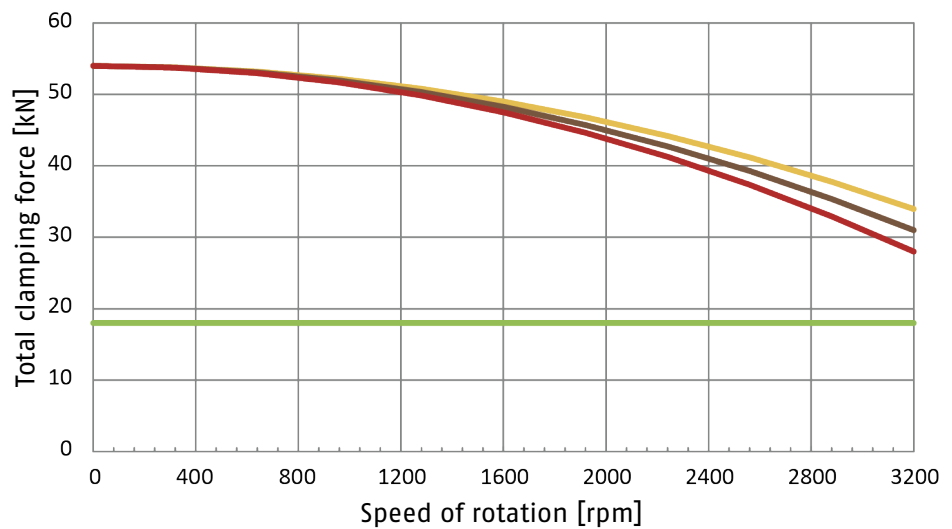



### Clamping force / speed diagram ROTA 2B 200

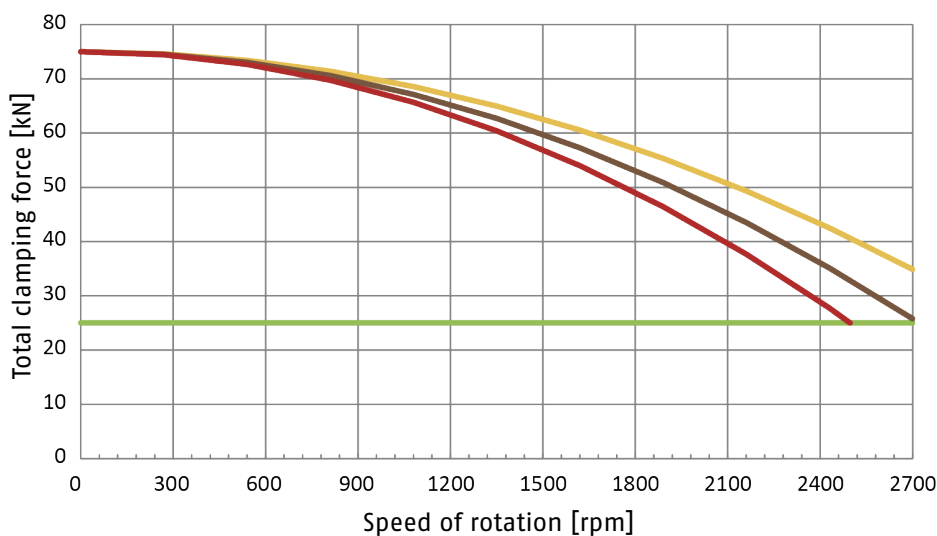

Colour	Jaw ID	Weight [kg]
	2 SWK 200	2.1
	2 SWK 200	2.6
	2 SWK 200	4.1
	Minimum required clamping force 33%	







### Clamping force / speed diagram ROTA 2B 250

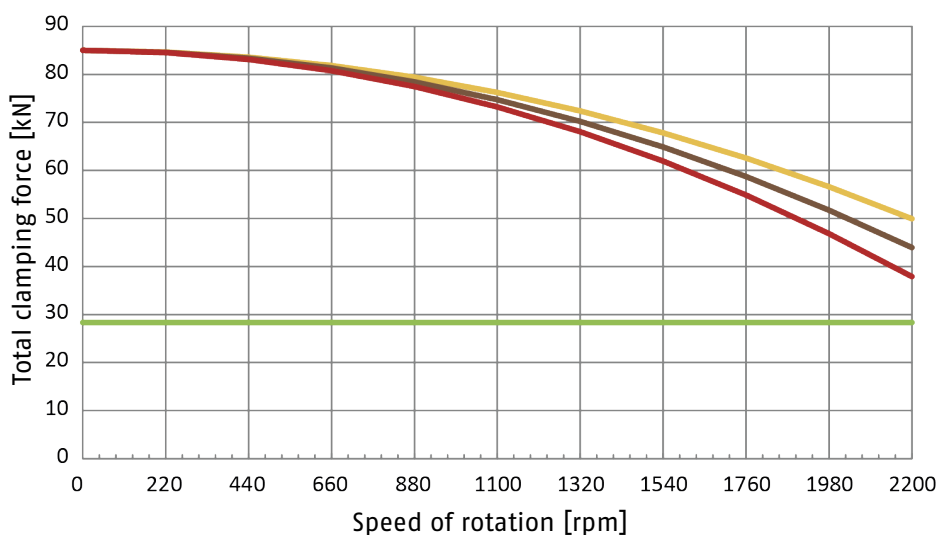

Colour	Jaw ID	Weight [kg]
	 2 SRK 250	3.0
	 2 SRK 250	4.0
	 2 SRK 250	5.5
	Minimum required clamping force 33%	







### Clamping force / speed diagram ROTA 2B 315

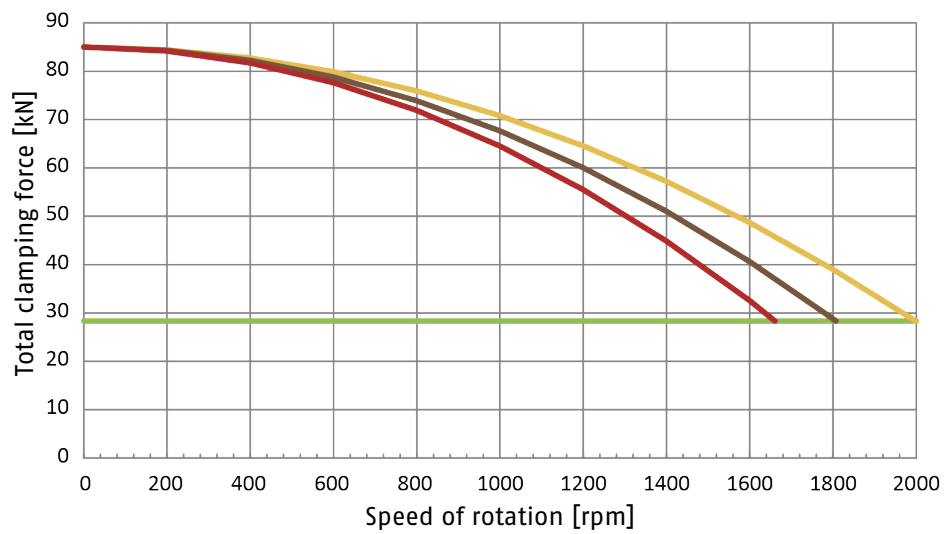

Colour	Jaw ID	Weight [kg]
	 2 SRK 315	5.0
	 2 SRK 315	7.0
	 2 SRK 315	9.0
	Minimum required clamping force 33%	

### Clamping force / speed diagram ROTA 2B 400



Colour	Jaw ID	Weight [kg]
	 2 SRK 400	5.0
	 2 SRK 400	7.0
	 2 SRK 400	9.0
	Minimum required clamping force 33%	

### 3.3 Calculations for clamping force and speed

Missing information or specifications can be requested from the manufacturer.

#### Legend

$F_c$	Total centrifugal force [N]	$M_{cAB}$	Centrifugal torque of top jaws [Kgm]
$F_{sp}$	Effective clamping force [N]	$M_{cGB}$	Centrifugal torque of base jaws [Kgm]
$F_{spmin}$	minimum required clamping force [N]	$n$	Speed of rotation [RPM]
$F_{sp0}$	Initial clamping force [N]	$r_s$	Center of gravity radius [mm]
$F_{spz}$	Cutting force [N]	$r_{sAB}$	Center of gravity radius of top jaw [mm]
$m_{AB}$	Mass of one top jaw [kg]	$s_{sp}$	Safety factor for clamping force
$m_B$	Mass of chuck jaw set [kg]	$s_z$	Safety factor for machining
$M_c$	Centrifugal torque [kgm]	$\Sigma_s$	Max. clamping force of lathe chuck [N]

### 3.3.1 Calculation of the required clamping force in case of a given rpm

The **initial clamping force**  $F_{sp0}$  is the total force impacting radially on the workpiece via the jaws due to actuation of the lathe chuck during shutdown. Under the influence of rotation, the jaw mass generates an additional centrifugal force. The centrifugal force reduces or increases the initial clamping force depending on whether gripping is from the outside inwards or from the inside outwards.

The sum of the initial clamping force  $F_{sp0}$  and the **total centrifugal force**  $F_c$  is the **effective clamping force**  $F_{sp}$ .

$$F_{sp} = F_{sp0} \mp F_c \text{ [N]}$$

(-) for gripping from the outside inwards

(+) for gripping from the inside outwards



#### **! DANGER**

**Risk to life and limb of the operating personnel and significant property damage when the RPM limit is exceeded! With gripping from the outside inwards, and with increasing RPM, the effective clamping force is reduced by the magnitude of the increasing centrifugal force (the forces are opposed). When the RPM limit is exceeded, the clamping force drops below the required minimum clamping force  $F_{spmin}$ . Consequently, the workpiece is released spontaneously.**

- Do not exceed the calculated RPM.
- Do not fall below the necessary minimum clamping force.

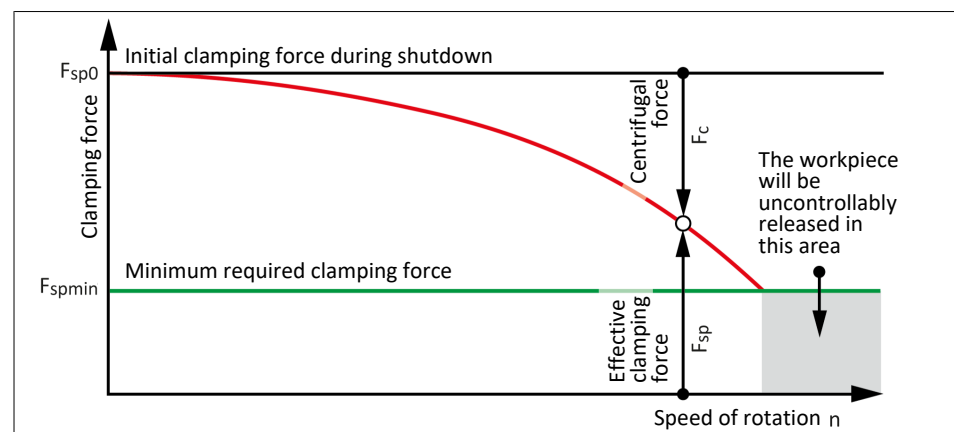

*Reduction in effective clamping force by the magnitude of the total centrifugal force, for gripping from the outside inwards.*

The required effective clamping force for machining  $F_{sp}$  is calculated from the product of the **machining force**  $F_{spz}$  and the **safety factor**  $S_z$ . This factor takes into account uncertainties in the calculation of the machining force. According to VDI 3106:  $S_z \geq 1.5$ .

$$F_{sp} = F_{spz} \cdot S_z \text{ [N]}$$

From this we can derive the calculation of the initial clamping force during shutdown:

$$F_{sp0} = S_{sp} \cdot (F_{sp} \pm F_c) \text{ [N]}$$

(+) for gripping from the outside inwards

(-) for gripping from the inside outwards

### NOTICE

**This calculated force must not be larger than the maximum clamping force  $\Sigma S$  engraved on the lathe chuck.**

See also "Lathe chuck data" table ▶ 3.1 [16]

From the above formula it is evident that the sum of the effective clamping force  $F_{sp}$  and the total centrifugal force  $F_c$  is multiplied by the **safety factor for the clamping force  $S_{sp}$** . According to VDI 3106, the following also applies here:  **$S_{sp} \geq 1.5$** .

The **total centrifugal force  $F_c$**  is dependent on both the sum of the masses of all jaws and on the center of gravity radius and the rpm.

### NOTICE

**For safety reasons, in accordance with DIN EN 1550, the centrifugal force may be a maximum of 67% of the initial clamping force.**

The formula for the calculation of the total centrifugal force  $F_c$  is:

$$F_c = \sum(m_B \cdot r_s) \cdot \left(\frac{\pi \cdot n}{30}\right)^2 = \sum M_c \cdot \left(\frac{\pi \cdot n}{30}\right)^2 \text{ [N]}$$

For this,  **$n$  is the given speed of rotation** in RPM. The product  **$m_B \cdot r_s$  is referred to as the centrifugal torque  $M_c$** .

$$M_c = m_B \cdot r_s \text{ [kgm]}$$

In case of toolholders with split chuck jaws, i.e., with base jaws and top jaws, for which the base jaws change their radial position only by the stroke amount, the **centrifugal torque of the base jaws  $M_{cGB}$**  and the **centrifugal torque of the top jaws  $M_{cAB}$**  need to be added:

$$M_c = M_{cGB} + M_{cAB} \text{ [kgm]}$$

The centrifugal torque of the base jaws  $M_{cGB}$  can be found in the table "Lathe chuck data" ▶ 3.1 [16]. The centrifugal torque of the top jaws  $M_{cAB}$  is calculated as per:

$$M_{cAB} = m_{AB} \cdot r_{sAB} \text{ [kgm]}$$

### 3.3.2 Calculation example: required initial clamping force for a given speed

#### Required initial clamping force $F_{sp0}$ for a given RPM $n$

The following data is known for the machining job:

- Gripping from the outside in (application-specific)
- Machining force  $F_{spz} = 3000 \text{ N}$  (application-specific)
- max. RPM  $n_{max} = 3200 \text{ RPM}$  ("Lathe chuck data" table)
- RPM  $n = 1200 \text{ RPM}$  (application-specific)
- Mass of one (!) top jaw  $m_{AB} = 5.33 \text{ kg}$  (application-specific)
- Center of gravity radius of top jaw  $r_{sAB} = 0.107 \text{ m}$  (application-specific)
- Safety factor  $S_z = 1.5$  (according to VDI 3106)
- Safety factor  $S_{sp} = 1.5$  (according to VDI 3106)

**Note:** Masses of the jaw mounting screws and T-nuts are not taken into account.

First the required effective clamping force  $F_{sp}$  is calculated using the machining force stated:

$$F_{sp} = F_{spz} \cdot S_z = 3000 \cdot 1.5 \Rightarrow \mathbf{F_{sp} = 4500 \text{ N}}$$

Initial clamping force during shutdown:

$$F_{sp0} = S_{sp} \cdot (F_{sp} + F_c)$$

Calculation of total centrifugal force:

$$F_c = \sum M_c \cdot \left(\frac{\pi \cdot n}{30}\right)^2$$

For two-part chuck jaws, the following applies:

$$M_c = M_{cGB} + M_{cAB}$$

Take the centrifugal torque of the base jaw and top jaw specified from the "Lathe chuck data" table:

$$\mathbf{M_{cGB} = 0.319 \text{ kgm}}$$

For the centrifugal torque of the top jaw, the following applies:

$$M_{cAB} = m_{AB} \cdot r_{sAB} = 5.33 \cdot 0.107 \Rightarrow \mathbf{M_{cAB} = 0.57 \text{ kgm}}$$

Centrifugal torque for one jaw:

$$M_c = 0.319 + 0.571 \Rightarrow \mathbf{M_c = 0.89 \text{ kgm}}$$

The chuck has 3 jaws, the total centrifugal torque is:

$$\sum M_c = 3 \cdot M_c = 3 \cdot 0.889 \Rightarrow \mathbf{\sum M_c = 2.667 \text{ kgm}}$$

The total centrifugal force can now be calculated:

$$F_c = \sum M_c \cdot \left(\frac{\pi \cdot n}{30}\right)^2 = 2.668 \cdot \left(\frac{\pi \cdot 1200}{30}\right)^2 \Rightarrow \mathbf{F_c = 42131 \text{ N}}$$

Initial clamping force during shutdown that was sought:

$$F_{sp0} = S_{sp} \cdot (F_{sp} + F_c) = 1.5 \cdot (4500 + 42131) \Rightarrow \mathbf{F_{sp0} = 69947 \text{ N}}$$

### 3.3.3 Calculation of the permissible speed in case of a given initial clamping force

#### Calculation of the permissible RPM $n_{perm}$ in case of a given initial clamping force $F_{sp0}$

The following formula can be used to calculate the permissible RPM for a given initial clamping force during shutdown:

$$n_{zul} = \frac{30}{\pi} \cdot \sqrt{\frac{F_{sp0} - (F_{spz} \cdot S_z)}{\sum M_c}} \quad [\text{min}^{-1}]$$

#### NOTICE

**For safety reasons, the calculated permissible RPM may not exceed the maximum RPM inscribed on the lathe chuck!**

#### Example of calculation: Permissible RPM for a given effective clamping force

The following data is known from previous calculations:

- Initial clamping force during shutdown  $F_{sp0} = 17723 \text{ N}$
- Machining force for machining job  $F_{spz} 3000 \text{ N}$  (application-specific)
- Total centrifugal torque of all jaws  $\sum M_c = 2,668 \text{ kgm}$
- Safety factor  $S_z = 1.5$  (according to VDI 3106)
- Safety factor  $S_{sp} = 1.5$  (according to VDI 3106)

#### NOTE:

Masses of the jaw mounting screws and T-nuts are not taken into account.

Identifying the permissible RPM:

$$n_{zul} = \frac{30}{\pi} \cdot \sqrt{\frac{F_{sp0} - (F_{spz} \cdot S_z)}{\sum M_c}} = \frac{30}{\pi} \cdot \sqrt{\frac{69947 - (3000 \cdot 1.5)}{2.668}} \Rightarrow n_{zul} = 1495 \text{ min}^{-1}$$

The calculated RPM  $n_{perm} = 1495 \text{ RPM}$  is smaller than the maximum permissible RPM of the lathe chuck  $n_{max} = 3200 \text{ RPM}$  (see "Lathe chuck data" table ▶ 3.1 [16]).

**This calculated RPM may be used.**

### 3.4 Grades of Accuracy

Tolerances for radial and axial run-out accuracy correspond to the Technical Supply Terms for lathe chucks as per DIN ISO 3442-3.

### 3.5 Permissible imbalance DIN ISO 21940-11

The ROTA 2B in ungreased state without T-nuts and top jaws corresponds to the balancing quality class 6.3 (according to DIN ISO 21940-11). Residual imbalance risks may arise due to insufficient rotation compensation being achieved (see DIN EN 1550 6.2 e). This applies particularly to high speeds, asymmetrical workpieces or the use of various top jaws, as well as uneven application of lubricants. In order to prevent damage resulting from these residual risks, the entire rotor is to be dynamically balanced in accordance with DIN ISO 21940-11.

## 4 Function

### 4.1 Function and handling

The ROTA 2B wedge hook chuck is operated by circular full or hollow clamp cylinder or static hydraulic cylinder. The axial tension and pressure forces are converted via the wedge hook angle in the piston and base jaw into radial chuck clamping force.

The chuck jaw clamping and opening movement is preset by the clamping cylinder. The fine serrations on the base jaw are suitable for standard jaws and special jaws for awkward workpiece shapes. All ROTA 2B sizes can also be supplied with slot and tenon base jaws (up to size 125 with slot and tenon only).

The top jaws are moved or changed with the clamps open.

ROTA 2B's long jaw stroke makes it particularly suitable for bridging long travel distances from workpiece shapes to clamping position. This makes this chuck especially appropriate for fittings and cast components. ROTA 2B chucks installation height has been improved (shorter).

### 4.2 Replacement or renewal of jaws

Clamping jaws for maximum clamping repeat accuracy have to be bored out or ground out in the clamping chuck under clamping pressure.

When boring or grinding out, ensure that the turning ring or bolt is clamped by the **top jaw**- and not the base jaw.

Tighten jaw fastening screws (Screw-quality 12.9) to specified torque ▶ 5.1 [ 26].

**Tighten the jaw fastening screws with a dynamometric key.**

## 5 Mounting

### 5.1 Torques per screw

Tightening torques for mounting screws used to clamp the chuck on lathes or other suitable technical equipment (screw quality 10.9)

Screw size	M6	M8	M10	M12	M14	M16	M18	M20	M22	M24	M27	M30
Admissible torque $M_A$ (Nm)	13	28	50	88	120	160	200	290	400	500	1050	1500

Tightening torques for mounting screws used to attach top jaws onto the chuck (screw quality 12.9)

Screw size	M6	M8	M10	M12	M14	M16	M20	M24
Max. admissible torque $M_A$ (Nm)	16	30	50	70	130	150	220	450

### 5.2 Mounting in general

#### 5.2.1 Pre-assembly measures

Carefully lift the product (e.g. using suitable lifting gear) from the packaging.



#### **⚠ WARNING**

##### **Risk of injury due to unexpected movements!**

If the power supply is switched on or residual energy remains in the system, components can move unexpectedly and cause serious injuries.

- Before starting any work on the product: Switch off the power supply and secure against restarting.
- Make sure, that no residual energy remains in the system.



#### **⚠ CAUTION**

##### **Danger of injury due to sharp edges and rough or slippery surfaces**

- Wear personal protective equipment, particularly protective gloves.

Check the delivery for completeness and for transport damage.

In order to achieve high run-out accuracy of the chuck, the machine side must be aligned before mounting the chuck. To do this, check the mounting surfaces for radial and axial run-out using a dial indicator.

**A maximum concentricity error of 0.01 mm should be ensured for the centring of the mount and a maximum axial run-out error of 0.01 mm for the contact surfaces. In addition, the flat surface must be checked for evenness using a straight edge (flat surface deburred and clean at the bore holes).**

Radial and axial run-out tolerances of the chuck:

Chuck size [mm]	Max. Radial run-out tolerance [mm]	Max. Axial run-out tolerance [mm]
≤ 315	0.02	0.02
≤ 400	0.03	0.03
≤ 800	0.04	0.04
≤ 1200	0.05	0.05
≤ 1600	0.06	0.06

### 5.2.2 Chuck assembly options

If the interface of the machine spindle and chuck is identical, assembly is carried out without assembly preparation. If the interface of the machine spindle deviates from the interface of the chuck, a connecting flange must be installed before assembly.

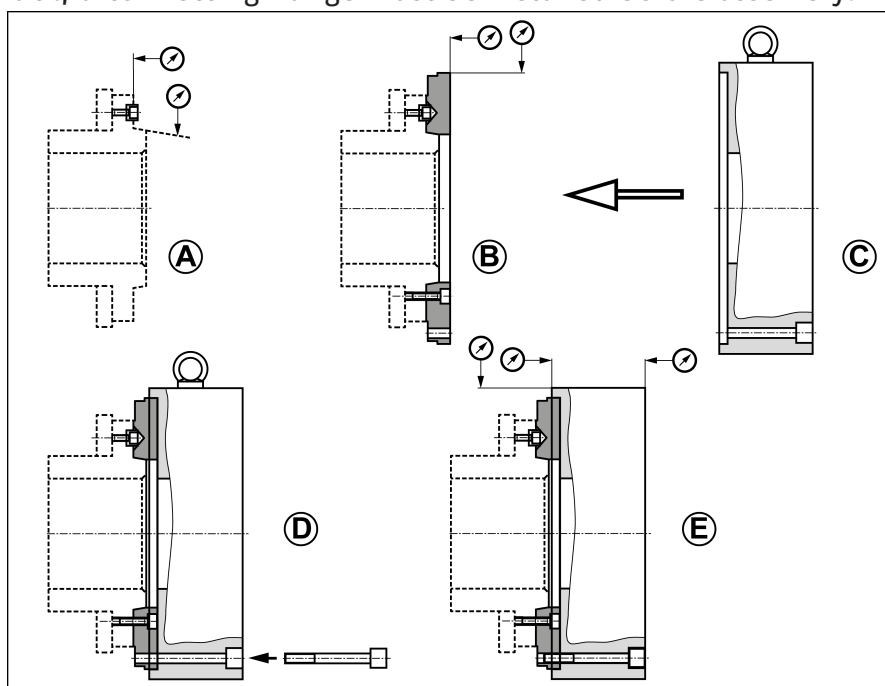

Chuck assembly

- Direct assembly of the chuck to the machine spindle
- Assembly of the chuck with connecting flange
  - Direkt flange (insert ring)
  - Reduction flange
  - Expansion flange

#### NOTICE

When mounting with the connecting flange, never allow the outer rim of the chuck body to make contact. The flange must support on the entire surface.

#### NOTICE

Use a crane to install the chuck. Fasten the chuck to the eye bolt provided for this purpose (see Fig. "Chuck assembly" – C) The eye bolt must be removed prior to commissioning.

### 5.3 Mounting of the Chuck to the Machine Spindle

#### Checking the chuck mounting:

Completely remove cylinder screws (item 15) of the top jaws completely with the T-nuts.

Move the drawbar (or drawtube) to the foremost position by actuating the clamping cylinder. If necessary, screw the adapter part onto the draw tube.

Push the chuck piston (3) into its foremost position.

#### **NOTICE**

#### **No stop in front of the piston position**

The adaptation between the drawtube and drawbar of the machine and the chuck piston should be designed that in the stop is in the clamping cylinder forwards. In the chuck is the stop backwards. In Fig. 2, is the chuck marked in the maximum possible front piston position in which the chuck piston not strikes.

For questions regarding the piston position for self-installation, contact our technical support service during our business hours.

---

### ROTA 2B 125

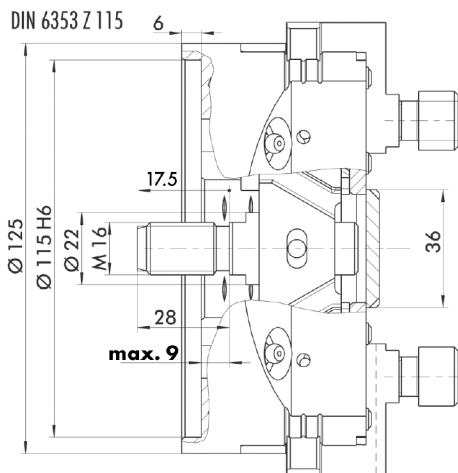

### ROTA 2B 160

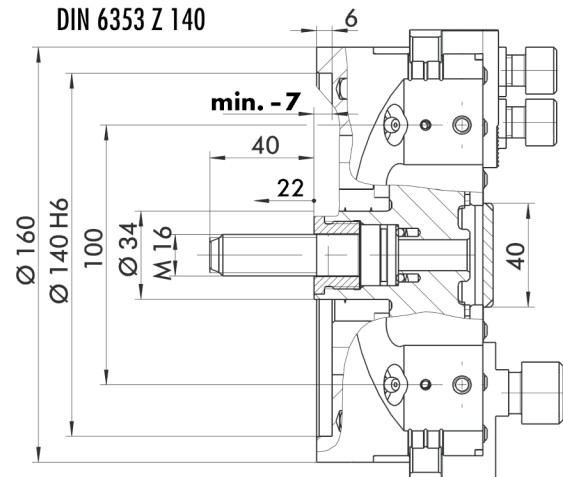

### ROTA 2B 200

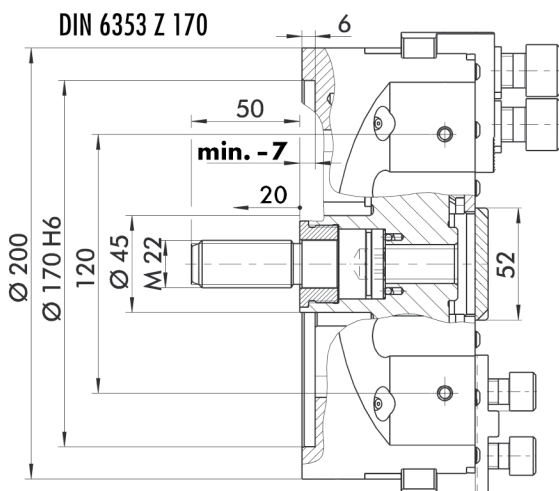

### ROTA 2B 250

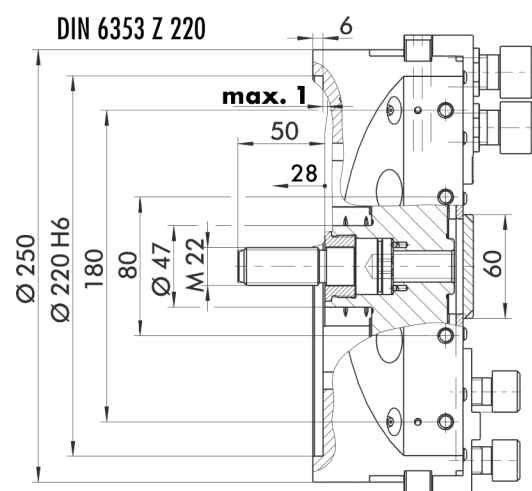

### ROTA 2B 315

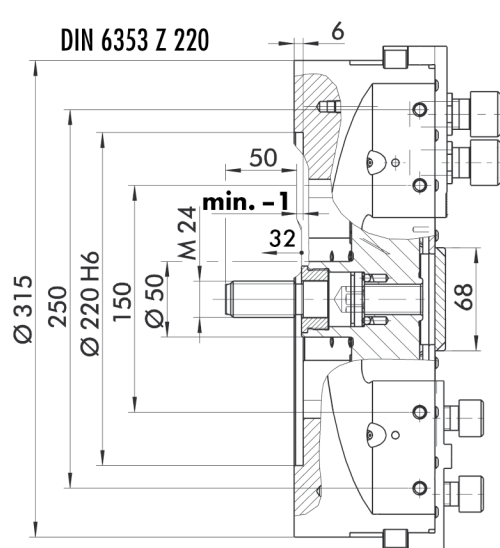

### ROTA 2B 400

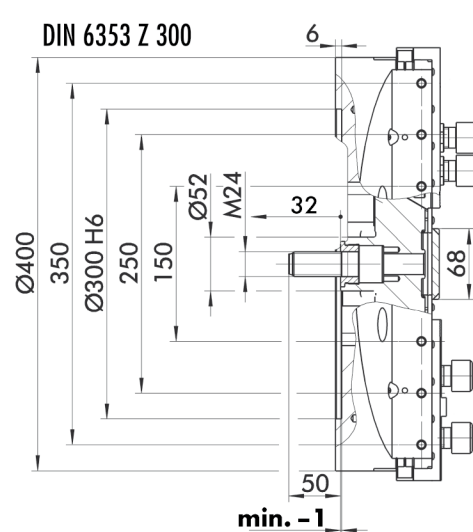

Maximal possible front piston position in which the chuck piston not strikes (measure in mm)

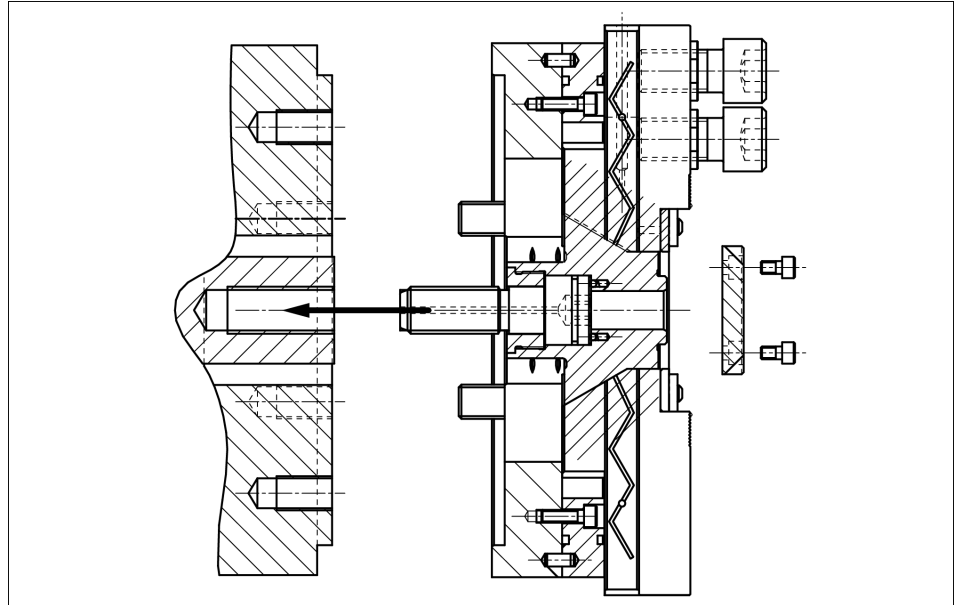

*Mounting the chuck onto the machine spindle*

**for ROTA 2B 125:**

1. The complete chuck has to be mounted flush with the centre of the spindle onto the draw bar to the stop.
2. The chuck needs to be turned back until the mounting bolts line up with the mounting threads of the spindle.

**for ROTA 2B 160 to 400:**

1. Undo 4 screws (item 20) in chuck cover (item 4) and remove cover.
2. Use an assembly belt or a lifting eye bolt to hold the chuck in alignment with the centre of the spindle in front of the spindle nose.
3. Using a socket head screw to tighten screw (item 6) on the draw bar to the stop.
4. Screw in the fastening screws (item 21) and **tighten lightly**.
5. Check the chuck for concentricity and axial run-out and, if necessary, align it with the outer diameter using light plastic hammer blows. (See Fig. "Assembly of the lathe chuck" - E and the table of maximum achievable concentricity and axial run-out tolerances, ▶ 5 [□ 26].
6. Then tighten the fastening screws alternately using a torque wrench. Observe the specified maximum tightening torques, ▶ 5.1 [□ 26].
7. Check the concentricity and face runout at the control rim.
8. Check the function and the size of the operating force.
9. Check that the base jaws run smoothly and that the jaw stroke is correct.

Locate top jaws with sliding block and screws using markings 1 and 2 on base jaw (item 15).

To dismantle the chuck, follow the instructions in reverse order.

## 5.4 Mounting chuck on Opus B cylinder

1. The contact face has to be chamfered and clean at the bores.
2. Remove chuck and Opus B cylinder from packaging and check they are complete and not damaged.
3. Remove top jaw cylindrical screws (item 15) together with Trnuts.
4. Connect Opus B cylinder to hydraulic system. Place substructure cylinder (Opus B) into customer-made bore and secure using the screws supplied.
5. Advance chuck piston (item 3) to the front position.
6. Align chuck to piston centre and screw onto the Opus B cylinder to the stop by rotating around its own axis. Turn chuck back until the countersunk screw overlaps the threads in the Opus B.
7. Align Opus B if necessary. Tighten chuck fastening screws (item 21) alternately. Observe the specified maximum tightening torques ▶ 5.1 [□ 26].
8. Check the function and the size of the operating force.
9. Check that the base jaws run smoothly and that the jaw stroke is correct.

Locate top jaws with sliding block and screws using markings 1 and 2 on base jaw (item 15).

To dismantle the Opus B, follow the instructions in reverse order.

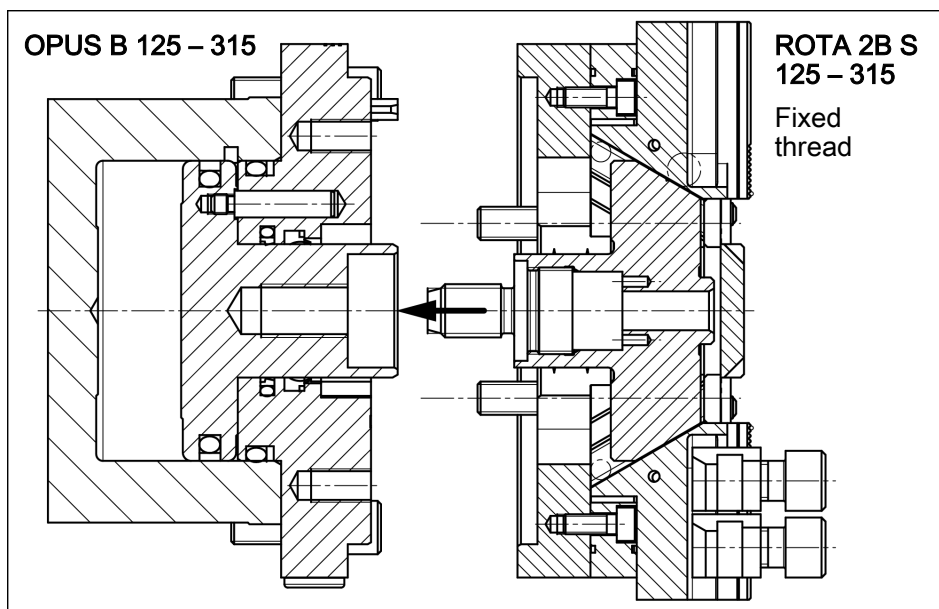

Mounting chuck on Opus B cylinder

## **5.5 ROTA 2B S – KONTEC (125 – 315)**

ROTA 2B S have in general a solid connecting thread. The chucks has to be always mounted by turning around their own axis onto the clamping cylinder. The screw piece is secured on the chuck side against twisting and does not additionally be secured.

## 6 Maintenance

### 6.1 Lubrication



#### ⚠ WARNING

##### **Risk of injury through contact with lubricants!**

Skin or eye contact with lubricants can cause irritation and allergic reactions.

- Avoid skin or eye contact with lubricants.
- Wear safety goggles and protective gloves.

To maintain the safe functioning and high quality of the chuck, it must be lubricated regularly at all lubrication points. For optimum grease distribution, the chuck must be lubricated in the lubricating position (► 6.2 [33]).

Depending on the operating conditions, the function and clamping force must be checked after a certain period of operation (► 6.3 [33]). Only perform the clamping force test with a calibrated clamping force tester (SCHUNK IFT). If the chuck is used over several clamping cycles in the short stroke range (< 50% clamping stroke), it is recommended to perform an empty stroke regularly to maintain the clamping force at a consistently high level.

**Lubricate the chuck evenly in order to avoid large imbalances.**

### 6.2 Lubricating position

The following procedure should be followed to ensure optimum distribution of the lubricant:

- Open the chuck and move it to the outer end position.
- Lubricate the chuck at the 2 grease nipples (item 23) with LINOMAX plus.
  - 1-2 grease gun strokes must be applied to the chuck at each lubrication point. 1 stroke for sizes 125-160 and 2 strokes for sizes 200-400.
- Perform several empty strokes over the entire travel range of the chuck.

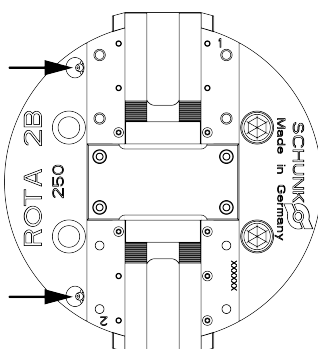

Fig. 1: Lubricating points

### 6.3 Maintenance and lubrication plan

The specified intervals are guide values and must be adjusted by the operator depending on the ambient and operating conditions and the frequency of use of the clamping device used. To determine a suitable lubrication interval for the respective application, regular clamping force tests must be carried out. If

only 80% of the maximum clamping force is reached, the clamping device must be lubricated. In accordance with VDI 3106, it must be ensured that sufficient clamping force is available for the application.

Maintenance task	Interval
Lubricate	Every 24 operating hours
Check clamping force	To be determined by the operator
Complete cleaning / disassembly	Annually / after 2500 operating hours

### 6.4 Central oil lubrication

ROTA 2B chucks (for stationary use) can also be supplied with central oil lubrication as an option. Lubricate the chuck regularly appropriate to the application / use. Lubricating oil VG220 DIN 51519 is applied to the bottom of the chuck into a bore.

#### Important note

The chuck should always be lubricated in the position in which the base jaws are radially outermost. (This corresponds to the front piston position).

As a rule, a 3 second 10 to 30 bar pulse should be applied to the chuck 3 – 6 times an hour. Two gauge cartridges ensure that the oil is distributed evenly within the chuck.

### 6.5 Disassembly and assembly of the Chuck

#### NOTE

**Chuck must be removed before dismantling!**

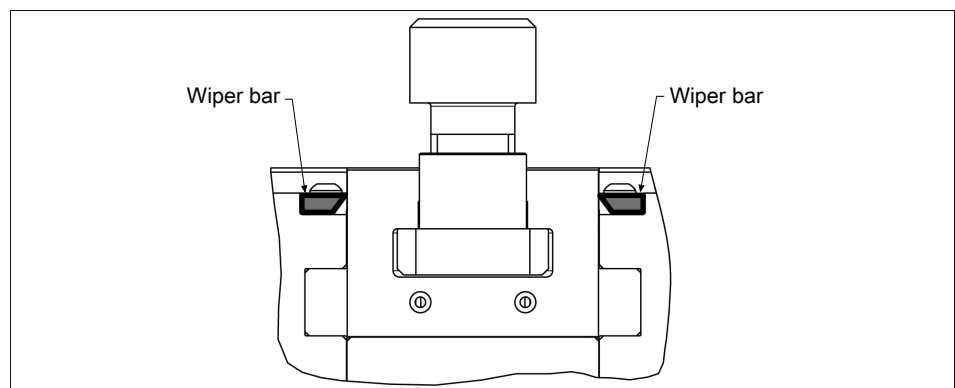

*Position of the wiper bars*

1. Remove all T-nuts and screws (item 15) from base jaw.
2. Remove countersunk screws (item 22) and wiper bars (item 10 and 11). When assembling the chuck ensure that the pointed side of the wiper bar is uppermost.
3. Undo cylindrical screws (item 20) and remove cover (item 4).
4. Unscrew set screw (item 30) out of the chuck.

**NOTE**

**When assembling, ensure that the mark on the piston (item 3) is aligned with jaw guide 1 (engraved in chuck body).**

5. Turn chuck on its head and pull piston (item 3) out of the housing. Remove set screw (item 29). Unscrew nut from this assembly (item 5). The screw can now be taken out. Remove ball (item 25) and spring (item 24). Remove O-ring (item 36) from screw.
6. Turn chuck upwards on to its front. Push one base jaw to the stop in the direction of the other jaw. Undo screws (item 19) and pull out filler (item 8). Remove cylindrical pin (item 28). Remove O-ring (item 35) from filler.
7. The two base jaws (item 2) can now be pushed out of the chuck in the direction of the free jaw guide.

**NOTE**

**When assembling, ensure that the number of notches on the base jaw is identical to the numbering on the jaw guide in the chuck body (item 1).**

8. Undo screws (item 19) and pull out second filler (item 8). Remove cylindrical pin (item 28).
9. Remove O-ring (item 35) from filler.

**Chuck with optional central oil lubrication:**

- The two threaded plugs (item 12) can be unscrewed out of the chuck body (item 1). Take the two gauge cartridges (item 26) out of the chuck body.

Clean all parts of dirt and grease and check for damage. Before mounting, grease well with lubricant LINOMAX plus.

**NOTE**

**If parts are found to be damaged, they must be replaced by original SCHUNK replacement parts, or, in the case of standard parts, by parts with the appropriate DIN code (important too for screws – quality class).**

Mounting of the chuck follows in reverse order.

**6.6 Changing the stepped jaws**

When changing the top jaws the serration must be cleaned and greased with SCHUNK special grease LINOMAX plus.

**⚠ WARNING**

**Danger of personal injury and property damage caused by flying parts in case of spiral fracture of soft top jaws!**

Soft top jaws must be hardened in the area of the screw's counterbore.

**Just deep hardened no surface hardening.**

## 7 Storage

When storing the product for a longer period of time, observe the following points:

- Clean the product and lubricate it lightly.
- Store the product in a suitable transport container.
- Only store the product in dry rooms.
- Protect the product from major temperature fluctuations.

**NOTE:** Before recommissioning, clean the product and all attachments, check for damage, functionality and leaks.

## 8 Part lists

When ordering spare parts, it is essential to specify the type, size and above all the manufacturing no of the chuck.

**Seals, sealing elements, screw connections, springs, bearings, screws and wiper bars plus parts coming into contact with the workpiece are not covered by the warranty.**

Item	Designation	Quantity	Note
1	Chuck body	1	
2	Base jaw	1	
3	Piston	1	
4	Cover	1	
5	Nut	1	160 / 200 / 250 / 315 / 400
6	Mounting screw	1	
8	Filler	2	
10	Wiper bar, left	2	
11	Wiper bar, right	2	
15	T-nut with screws 12.9	2	125 / 160 / 200
	Tongue and groove screw 10.9	2	125 / 160 / 200
	T-nut with screws 12.9	4	250 / 315 / 400
	Tongue and groove screw 10.9	4	250 / 315 / 400
19	Screw	4	125
	Screw	2	160 / 200 / 250 / 315 / 400
20	Screw	4	
21	Screw	2	125
	Screw	4	160 / 200 / 250 / 315 / 400
22	Oval head screw	8	125
	Oval head screw	12	160 / 200 / 250
	Oval head screw	16	315
	Oval head screw	20	400
23	Lubricating nipple	2	
24	Pressure spring	2	
25	Steel ball	2	
28	Cylindrical pin	2	125
	Cylindrical pin	4	160 / 200 / 250 / 315 / 400
29	Set screw	1	
30	Set screw	1	
35	Quad ring	2	
36	O-ring	1	160 / 200 / 250 / 315 / 400
40	Eye-bolt	1	315 / 400
51	Set screw	2	400

### Optional central oil lubrication:

Item	Designation	Quantity	Note
12	Threaded plug with seal		
26	Gauge cartridge		

## 9 Section and exploded drawing

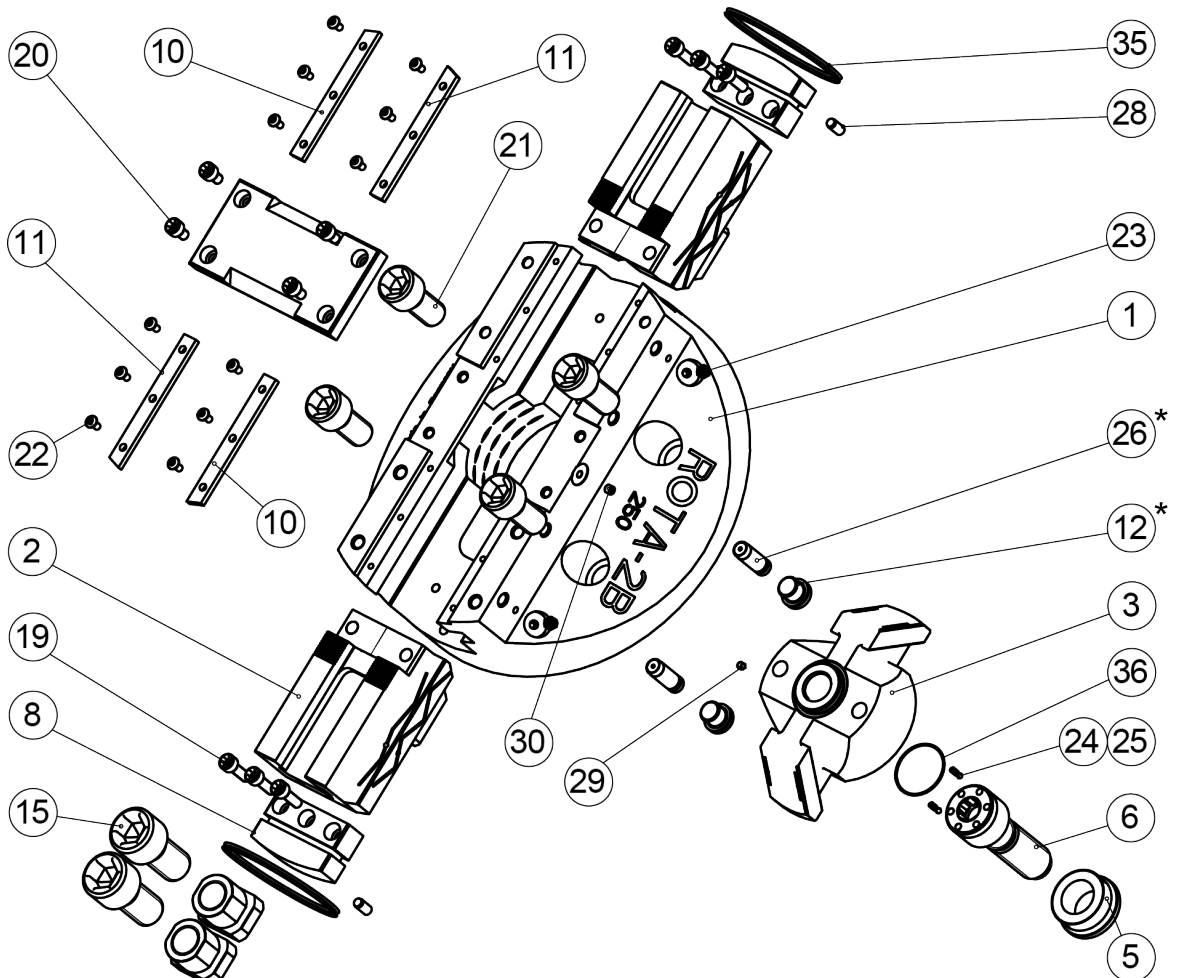
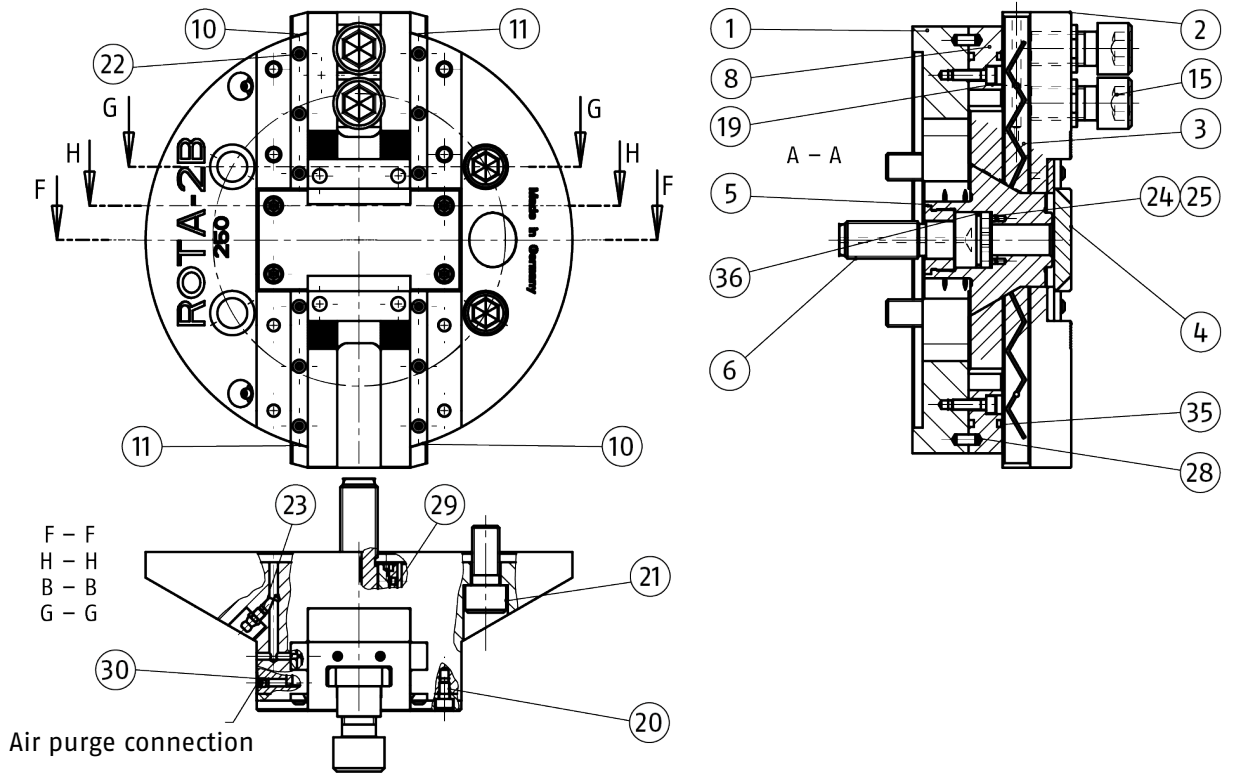

\* Central oil lubrication (option)

## 10 Manufacturer certificate

Manufacturer / Distributor:	H.-D. SCHUNK GmbH & Co. Spanntechnik KG Lothringer Str. 23 D-88512 Mengen
Product:	Lathe chuck
Designation:	ROTA
Type designation:	2B, NCA, NCD, NCE, NC, NCF, NCK, NCO, NCR, NCS, NCX, TH, THW, HSH, HSA, DFF

**Heinz-Dieter SCHUNK GmbH & Co. Spanntechnik KG** certifies that the above-mentioned products, when used as intended and in compliance with the operating manual and the warnings on the product, are safe according to the national regulations and:

- a **risk assessment** has been carried out in accordance with ISO 12100:2010.
- an **operating manual** for the assembly instructions has been created in accordance with the contents of the Machinery Directive 2006/42/EC Annex I No. 1.7.4.2. and the contents of the provisions of Annex VI of the Machinery Directive 2006/42/EC.
- the relevant basic and proven safety principles of the Annexes of **ISO 13849-2:2012**, taking into account the requirements of the documentation have been observed for the component. The parameters, limitations, ambient conditions, characteristic values, etc. for proper operation are defined in the operating manual.
- an  $MTTF_D$  value of 150 years can be estimated for mechanical components using the informative procedure in Table C.1 of ISO 13849-1:2015.
- **fault exclusion** against the fault "Unexpected release without pending release signal".
- the **fault exclusion** against the fault "Breakage during operation" in compliance with the parameters, limitations, ambient conditions, characteristic values and maintenance intervals, etc., specified in the operating manual.
- that internal bore diameters in the **pipe or control lines** are at least 2 mm for pneumatic clamping systems and at least 3 mm for hydraulic clamping systems

### Harmonized Standards applied:

- **ISO 12100:2010** Safety of machinery – General principles for design – Risk assessment and risk reduction
- **EN 1550:1997+A1:2008** Machine-tools safety – Safety requirements for the design and construction of lathe chucks for the workpiece mount

### Other related technical Standards and specifications:

- **ISO 702-1:2010-04** Machine tools – Connecting dimensions of spindle noses and lathe chucks – Part 1: front short-taper mount with screws
- **ISO 702-4:2010-04** Machine tools – Connecting dimensions of spindle noses and lathe chucks – Part 4: cylindrical mount
- **VDI 3106:2004-04** Determination of permissible RPM of lathe chucks (jaw chucks)

Mengen, 02nd of August 2023

*Signature: see original declaration*

*Signature: see original declaration*

p.p. Philipp Schröder  
Head of Development standard products

p.p. Alexander Koch  
Head of Engineering Design special products



H.-D. SCHUNK GmbH & Co.  
Spanntechnik KG

Lothringer Str. 23  
D-88512 Mengen  
Tel. +49-7572-7614-0  
info@de.schunk.com  
schunk.com

Folgen Sie uns | *Follow us*



Wir drucken nachhaltig | *We print sustainable*