



**MAGNOS – Test Equipment**

1945 – 2015

**70** Jahre

Superior Clamping and Gripping

**SCHUNK** ®

# MAGNOS – Test Equipment

## Targets

- Additional support for outside salesteam
- Replacement of the 2nd quality stock
- Quick and easy to use without any packaging
- Structure that is very robust and can be used some years
- Fast and effective process for Schunk and customer
- The service can check after return back very easily and fast
- Better appearance = better quality Besseres Erscheinungsbild

→ To win confidence and trust from customer

1945 – 2015  
**70**  
Jahre

# MAGNOS – Test Equipment

## Overview transport boxes

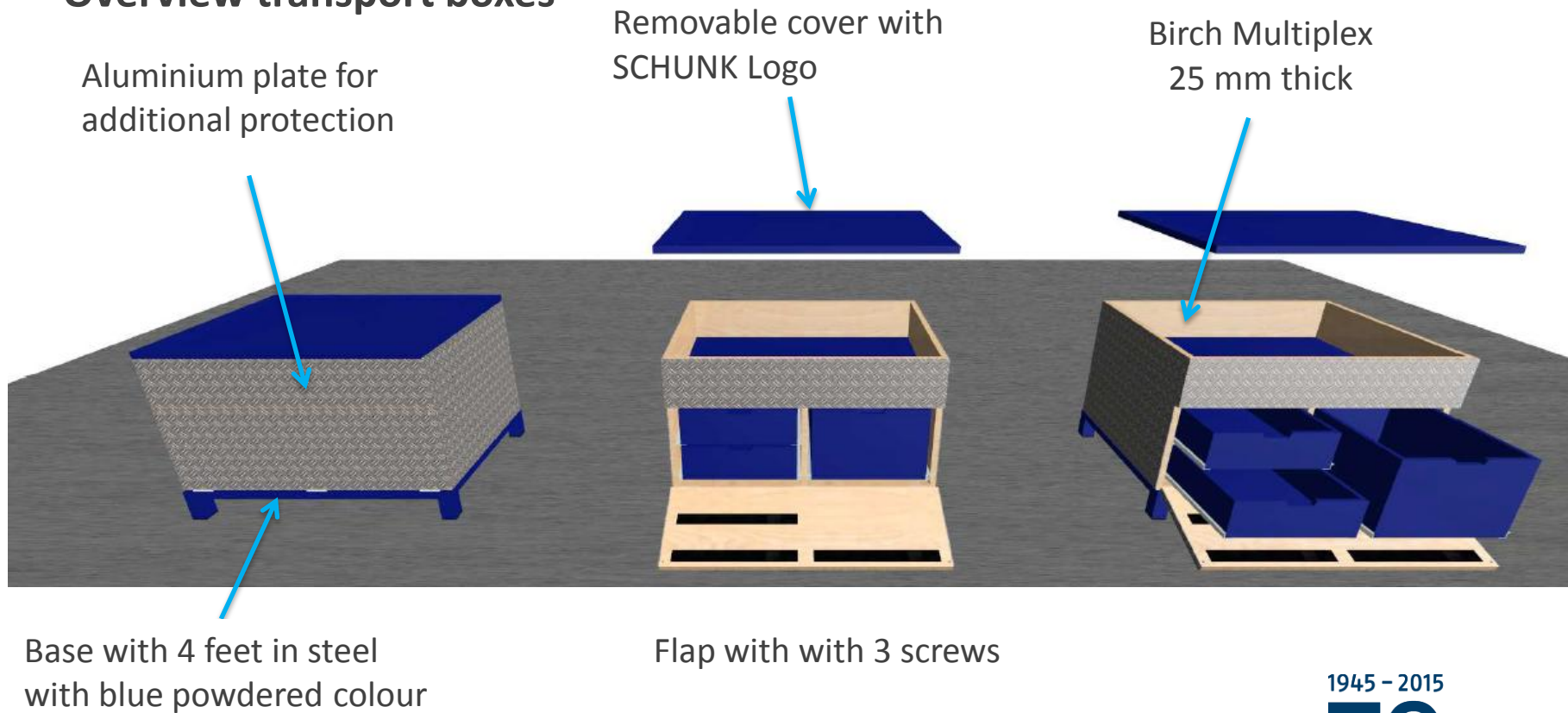

1945 - 2015  
**70**  
Jahre

# MAGNOS – Test Equipment

## Overview transport boxes

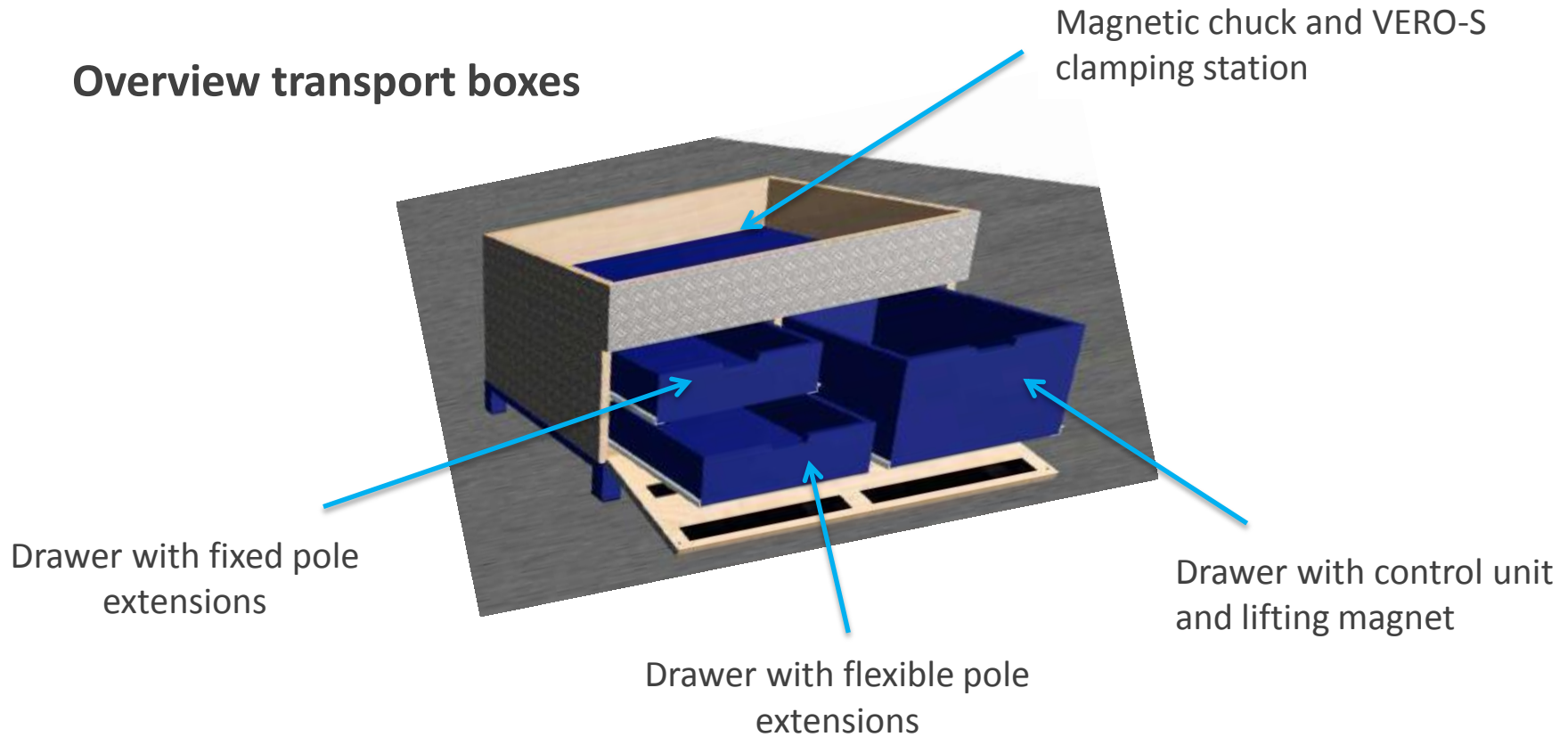

1945 – 2015  
**70**  
Jahre

# MAGNOS – Test Equipment

## Overview transport boxes

- Magnetic chuck sizes **32 x 32 pole size:**
  - 1x Magnetic chuck MFR-A1 430 x 430
  - 1x Magnetic chuck MFR-A1 600 x 315
- Magnetic chuck sizes **50 x 50 pole size:**
  - 1x Magnetic chuck MFR-A1 430 x 315
  - 4x Magnetic chuck MFR-A1 600 x 430
  - 2x Magnetic chuck MFR-A2 600 x 430
  - 2x Magnetic chuck MFR-A1 800 x 500
  - 2x Magnetic chuck MFR-A1 1000 x 500
- Magnetic chuck sizes **70 x 70 pole size:**
  - 2x Magnetic chuck MFR-A1 800 x 500
  - 1x Magnetic chuck MFR-A1 1000 x 500



16 transport boxes

1945 – 2015  
**70**  
Jahre

# MAGNOS – Test Equipment



## **MAGNOS transport boxes in shipping condition:**

The box consists out of a stably welded frame and a, with a aluminum cover sheet encapsulated, solid wood body. Therefore the content of the boxes are effectively protected against outer influences during the shippment.



## **Upper section:**

A magnetic chuck with VERO-S interface and a VERO-S clamping station are stored in the upper section.

1945 – 2015  
**70**  
Jahre

# MAGNOS – Test Equipment



## Upper section:

The magnetic chuck can be placed either individual or together with the VERO-S clamping station at the place of destination by the provided lifting magnet.



## Upper section:

According to the size of the magnetic chuck there is either a VERO-S 4-, 6- or 8-fold clamping station stored in the transport box.

1945 – 2015  
**70**  
Jahre

# MAGNOS – Test Equipment



## Accessories:

By unlocking of three screws a lateral cover at the box can be opened. Under this cover three drawers with the corresponding accessories emerge.



## Left upper drawer:

The fixed pole extensions as well as the cylindrical clamps and the workpiece stops are stored in this drawer.

1945 – 2015  
**70**  
Jahre

# MAGNOS – Test Equipment



## Left lower drawer:

All flexible pole extensions are stored in this drawer.





## Right drawer:

The lifting magnet and the control unit together with the remote control for the activation of the magnetic chuck are stored in the right drawer.

1945 – 2015  
**70**  
Jahre

# Processing form MAGNOS

## Test Equipment – Test version

Änderungsstand: 01		Bearbeitungsbogen MAGNOS für Kunden-Versuche			
<b>MAGNOS - Kundenversuche mit Vorführkisten</b>					
<b>Auszufüllen vom Schunk Fachberater / Kunde</b>					
<b>Name Fachberater</b>					
<b>Kundenname/ Nummer</b>					
<b>Ansprechpartner Kunde</b>					
<b>Hat der Kunde bereits Magnetspanntechnik im Einsatz</b>		<input type="checkbox"/> Ja		<input type="checkbox"/> Nein	
<b>Ziel der Anfrage</b>	<input type="checkbox"/> Reduzierung der Rüst-/ Spannzeit		<input type="checkbox"/> Höhere Ebenheit / Parallelität		<input type="checkbox"/> Bessere Zugänglichkeit
	<input type="checkbox"/> Reduzierung von Schwingungen		<input type="checkbox"/> Automatisierung		<input type="checkbox"/> wirtschaftlicher !
<b>Verwendete Schunk Artikel</b>	<input type="checkbox"/> MFR-A1	<input type="checkbox"/> 32x32 Polgröße	<input type="checkbox"/> ohne Polverlängerungen		
	<input type="checkbox"/> MFR-A2	<input type="checkbox"/> 50x50 Polgröße	<input type="checkbox"/> Polverlängerungen fest		
		<input type="checkbox"/> 70x70 Polgröße	<input type="checkbox"/> Polverlängerungen mobil		
					

1945 - 2015  
**70**  
Jahre

Superior Clamping and Gripping

**SCHUNK** ®

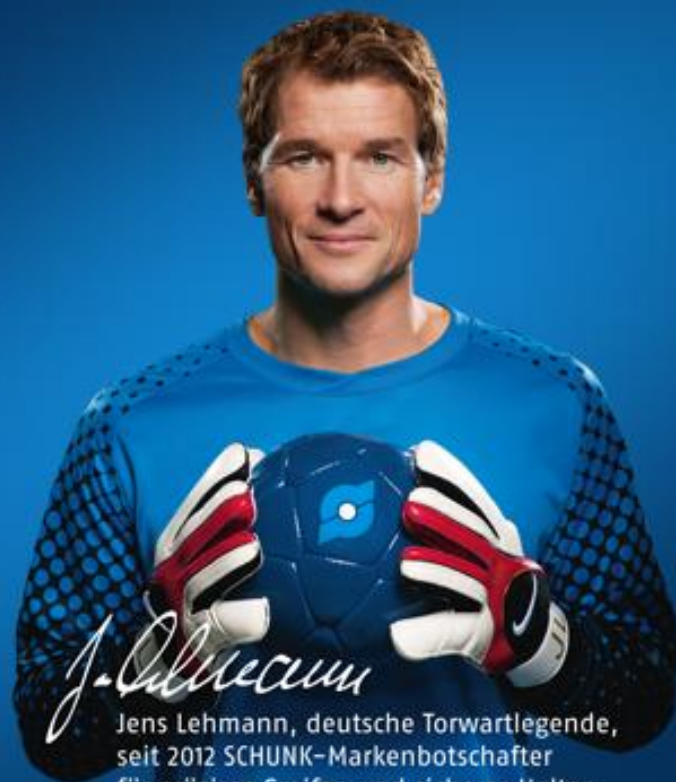

*J. Lehmann*

Jens Lehmann, deutsche Torwartlegende,  
seit 2012 SCHUNK-Markenbotschafter  
für präzises Greifen und sicheres Halten.  
[www.de.schunk.com/Lehmann](http://www.de.schunk.com/Lehmann)

