

TRIBOS Polygonal Clamping System

Clamping device SVP-Mini auto/SVP-RM auto

Assembly and operating manual



Imprint

Copyright:

This manual is protected by copyright. The author is SCHUNK GmbH & Co. KG. All rights reserved. Any reproduction, processing, distribution (making available to third parties), translation or other usage - even excerpts - of the manual is especially prohibited and requires our written approval.

Technical changes:

We reserve the right to make alterations for the purpose of technical improvement.

Document number: 0289045

Version: 04.00 | 14/08/2019 | en

© SCHUNK GmbH & Co. KG

All rights reserved.

Dear Customer,

thank you for trusting our products and our family-owned company, the leading technology supplier of robots and production machines.

Our team is always available to answer any questions on this product and other solutions. Ask us questions and challenge us. We will find a solution!

Best regards,

Your SCHUNK team

SCHUNK GmbH & Co. KG

Spann- und Greiftechnik

Bahnhofstr. 106 – 134

D-74348 Lauffen/Neckar

Tel. +49-7133-103-0

Fax +49-7133-103-2399

info@de.schunk.com

schunk.com

Table of contents

1	General	5
1.1	About this manual	5
1.1.1	Presentation of Warning Labels	5
1.1.2	Applicable documents	6
1.1.3	Sizes	6
1.2	Warranty	6
1.3	Scope of delivery	6
1.4	Accessories	7
2	Basic safety notes	8
2.1	Intended use	8
2.2	Not intended use	8
2.3	Constructional changes	8
2.4	Spare parts	9
2.5	Environmental and operating conditions	9
2.6	Personnel qualification	10
2.7	Personal protective equipment	11
2.8	Notes on safe operation	11
2.9	Transport	12
2.10	Malfunctions	12
2.11	Disposal	12
2.12	Notes on particular risks	13
2.13	Safety installations	15
3	Technical data	16
3.1	Clamping device	16
3.2	Polygonal jaw chuck	17
3.3	Accessories	18
3.4	Name plates	18
4	Design and description	20
4.1	Design	20
4.2	Description	20
5	Assembly	22
5.1	Connections	22
5.2	Assembling the clamping unit	22
5.3	Connecting the pump	24

6	Operation	26
6.1	Displays and controls.....	26
6.2	Operating the pump	27
6.2.1	Switching pump on and off	27
6.2.2	Overview user interface.....	28
6.2.3	"Main page" tab	29
6.2.4	Tab "Info 1"	31
6.2.5	"Info 2" tab	32
6.2.6	"Progress of work cycle" tab.....	33
6.3	Clamping and loosening the tool	34
6.4	Solving problems with clamping and loosening the tool	36
6.5	Analysis software.....	38
6.5.1	Installing the analysis software.....	38
6.5.2	Operating the analysis software	39
6.6	Operating the pump on battery power.....	45
6.6.1	Charging the battery	46
6.6.2	Replacing the battery	48
6.7	Actions after the usage.....	48
7	Troubleshooting	49
8	Maintenance	51
9	Declaration of conformity	52

1 General

1.1 About this manual

This manual contains important information for a safe and appropriate use of the product.

This manual is an integral part of the product and must be kept accessible for the personnel at all times.







Before starting work, the personnel must have read and understood this operating manual. Prerequisite for safe working is the observance of all safety instructions in this manual.

Illustrations in this manual are provided for basic understanding and may differ from the actual product design.

In addition to these instructions, the documents listed under [\(☞ 1.1.2, Page 6\)](#) are applicable.

1.1.1 Presentation of Warning Labels

To make risks clear, the following signal words and symbols are used for safety notes.

	<p> DANGER</p> <p>Danger for persons! Non-observance will inevitably cause irreversible injury or death.</p>
	<p> WARNING</p> <p>Dangers for persons! Non-observance can lead to irreversible injury and even death.</p>
	<p> CAUTION</p> <p>Dangers for persons! Non-observance can cause minor injuries.</p>
	<p>CAUTION</p> <p>Material damage! Information about avoiding material damage.</p>

1.1.2 Applicable documents

- General terms of business*
- Catalog data sheet of the purchased product *
- Assembly and operating manuals of the accessories *

The documents marked with an asterisk (*) can be downloaded on our homepage **schunk.com**

1.1.3 Sizes

This operating manual applies to the following sizes:

- SVP- Mini auto
- SVP- RM auto

1.2 Warranty

If the product is used as intended, the warranty is valid for 12 months from the ex-works delivery date under the following conditions:

- Intended use in 1-shift operation
- Observe the specified maintenance and lubrication intervals
- Observe the ambient conditions and operating conditions

Parts touching the workpiece and wear parts are not included in the warranty.

1.3 Scope of delivery

The scope of delivery includes

- TRIBOS clamping device SVP-RM auto or SVP- Mini in the variant ordered
- Pump incl. remote control
- Power supply (230 V or 110 V)

1.4 Accessories

The following accessories can be ordered for the clamping device:

- Cylindrical brush (see catalog Tool holder systems "Accessories")
- Bag for clamping device (Id.-no.: 9958225)
- Bracket (Id.-no.: 9954724)
- Battery (Id.-no.: 9958224)
- Battery charger 230 V (Id.-no.: 9958226)
- Battery charger 110 V (Id.-no.: 9958223)
- Power adapter 230 V power supply unit
 - Australia (Id.-no.: 9958139)
 - Italy (Id.-no.: 9958140)
 - England (Id.-no.: 9958141)
 - USA / Canada (Id.-no.: 9958142)
 - Switzerland (Id.-no.: 9958143)
 - South Africa (Id.-no.: 9961009)
 - France (Id.-no.: 9900076)

- An analysis software for showing and adjusting different parameters can be downloaded on the SCHUNK website.

For information regarding which accessory articles can be used with the corresponding product variants, see catalog data sheet.

2 Basic safety notes

2.1 Intended use

The clamping device may only be used for loading and replacing rotationally symmetric tools in TRIBOS-Mini or TRIBOS-RM polygonal jaw chucks.

- The product may only be used within the scope of its technical data, ([👉 3, Page 16](#)).
- The product is intended for industrial and industry-oriented use.
- Appropriate use of the product includes compliance with all instructions in this manual.

2.2 Not intended use

- Any utilization that exceeds or differs from the appropriate use is regarded as misuse.

Not intended use is

- using the clamping device outside or in an ATEX area,
- using the pump on lifting gear or lifting cylinders,
- connecting different hydraulic devices – other than the intended clamping devices – to the pump.

2.3 Constructional changes

Implementation of structural changes

By conversions, changes, and reworking, e.g. additional threads, holes, or safety devices can impair the functioning or safety of the product or damage it.

- Structural changes should only be made with the written approval of SCHUNK.

2.4 Spare parts

Use of unauthorized spare parts

Using unauthorized spare parts can endanger personnel and damage the product or cause it to malfunction.

- Use only original spare parts or spares authorized by SCHUNK.

2.5 Environmental and operating conditions

Required ambient conditions and operating conditions

Incorrect ambient and operating conditions can make the product unsafe, leading to the risk of serious injuries, considerable material damage and/or a significant reduction to the product's life span.

- Make sure that the product is used only in the context of its defined application parameters, ([👉 3, Page 16](#)).
- Ensure that the product is protected against sprayed water, vapors, contamination, and EMC influences during operation. Exceptions are products that are designed especially for contaminated environments.

Environment Operate the product under the following environmental conditions:

- Temperature range: +15°C to +40°C
- Relative humidity: 20 % to 80 %

Storage Store the product under the following conditions:

- Store the product under the following conditions:
- Store it dry and dust-free.
- Do not expose it to aggressive media.
- Storage temperature: +15°C to +40°C.
- Relative humidity: max. 60 %.

2.6 Personnel qualification

Inadequate qualifications of the personnel

If the personnel working with the product is not sufficiently qualified, the result may be serious injuries and significant property damage.

- All work may only be performed by qualified personnel.
- Before working with the product, the personnel must have read and understood the complete assembly and operating manual.
- Observe the national safety regulations and rules and general safety instructions.

The following personal qualifications are necessary for the various activities related to the product:

- Trained electrician** Due to their technical training, knowledge and experience, trained electricians are able to work on electrical systems, recognize and avoid possible dangers and know the relevant standards and regulations.
- Qualified personnel** Due to its technical training, knowledge and experience, qualified personnel is able to perform the delegated tasks, recognize and avoid possible dangers and knows the relevant standards and regulations.
- Instructed person** Instructed persons were instructed by the operator about the delegated tasks and possible dangers due to improper behaviour.
- Service personnel of the manufacturer** Due to its technical training, knowledge and experience, service personnel of the manufacturer is able to perform the delegated tasks and to recognize and avoid possible dangers.

2.7 Personal protective equipment

Use of personal protective equipment

Personal protective equipment serves to protect staff against danger which may interfere with their health or safety at work.

- When working on and with the product, observe the occupational health and safety regulations and wear the required personal protective equipment.
- Observe the valid safety and accident prevention regulations.
- Wear protective gloves to guard against sharp edges and corners or rough surfaces.
- Wear heat-resistant protective gloves when handling hot surfaces.
- Wear protective gloves and safety goggles when handling hazardous substances.
- Wear close-fitting protective clothing and also wear long hair in a hairnet when dealing with moving components.

2.8 Notes on safe operation

Incorrect handling of the personnel

Incorrect handling and assembly may impair the product's safety and cause serious injuries and considerable material damage.

- Avoid any manner of working that may interfere with the function and operational safety of the product.
- Use the product as intended.
- Observe the safety notes and assembly instructions.
- Do not expose the product to any corrosive media. This does not apply to products that are designed for special environments.
- Eliminate any malfunction immediately.
- Observe the care and maintenance instructions.
- Observe the current safety, accident prevention and environmental protection regulations regarding the product's application field.

2.9 Transport

Handling during transport

Incorrect handling during transport may impair the product's safety and cause serious injuries and considerable material damage.

- When handling heavy weights, use lifting equipment to lift the product and transport it by appropriate means.
- Secure the product against falling during transportation and handling.
- Stand clear of suspended loads.

2.10 Malfunctions

Behavior in case of malfunctions

- Immediately remove the product from operation and report the malfunction to the responsible departments/persons.
- Order appropriately trained personnel to rectify the malfunction.
- Do not recommission the product until the malfunction has been rectified.
- Test the product after a malfunction to establish whether it still functions properly and no increased risks have arisen.

2.11 Disposal

Handling of disposal

The incorrect handling of disposal may impair the product's safety and cause serious injuries as well as considerable material and environmental harm.

- Follow local regulations on dispatching product components for recycling or proper disposal.

2.12 Notes on particular risks



DANGER

Risk of fatal injury due to electric current!

Touching live parts poses an immediate risk of fatal injury by electrocution.

- Only allow a qualified electrician to perform work on electrical components.
- Prior to commencing work on electric components, restore to a de-energized state.
- In case of damage to the insulation, switch off the power supply immediately and arrange for a repair.
- Keep humidity away from live parts.



WARNING

Risk of injury due to unexpected movements!

If the power supply is switched on or residual energy remains in the system, components can move unexpectedly and cause serious injuries.

- Before starting any work on the product: Switch off the power supply and secure against restarting.
- Ensure that no residual energy remains in the system.



WARNING

Risk of injury due to hydraulic energies!

Hydraulically driven parts may move unexpectedly. If parts are damaged, hydraulic liquid may leak out under high pressure and causes serious injuries.

- Only qualified workers are allowed to work at hydraulic parts.
- Check the hose lines for damage after each use. If necessary, have the damage repaired.
- Do not adjust the pressure above the maximum value.
- Prevent the hydraulic liquid from getting in contact with your skin. Wear personal protective equipment.



! WARNING

Risk of injury due to hot hydraulic liquid!

In continuous operation the hydraulic liquid may heat up considerably. During operation valves and hydraulic connection lines may get very hot.

- Wear personal safety equipment for all works at hydraulic parts.
- Before working at hydraulic parts, make sure the hydraulic liquid has cooled down to environmental temperature.



CAUTION

Danger to the environment due to wrong handling of environmentally hazardous substances!

The hydraulic liquid contains toxic substances. Wrong handling, especially in case of incorrect disposal, may result in serious environmental damage.

- Collect spilled or leaking hydraulic liquid instantly and properly.
- Have hydraulic liquid disposed by a specialized company.

2.13 Safety installations

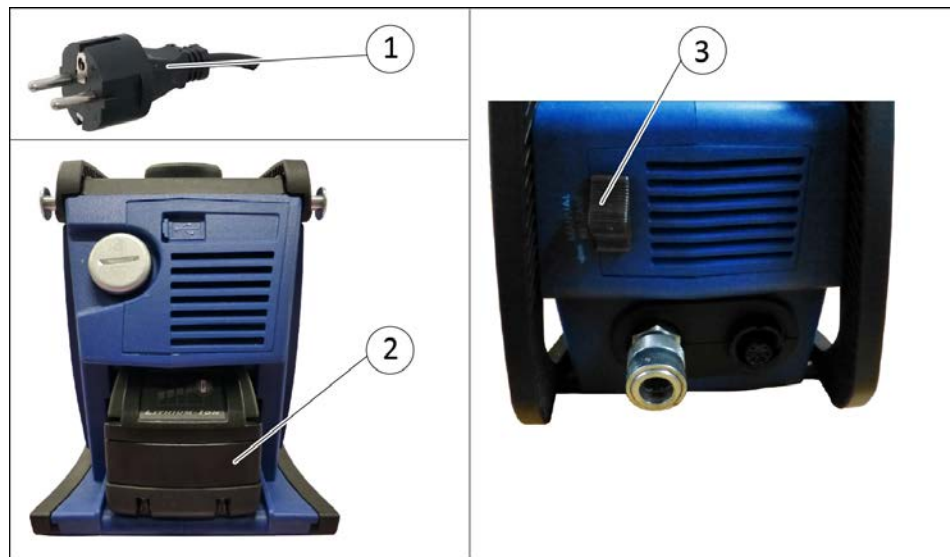

Safety installations at the clamping device

1	Power plug (230 V - variant depicted)
2	Battery (optional)
3	Return flow slide

Switch off the energy supply

In dangerous situations switch off energy supply immediately

- 1 Remove power plug (1) from the socket.
OR when battery-powered: Press left and right unlocking button simultaneously and remove battery from the pump, [\(👉 6.6, Page 45\)](#)

Reduce pressure in dangerous situations

- 1 If system pressure is not reduced by pressing "-", move the return flow slide downwards (3) into "MANUEL RELEASE" position.
- ⇒ In this position the hydraulic liquid flows back into the tank of the pump. The oil pressure decreases.

3 Technical data

3.1 Clamping device

Reference value	Value
Operating pressure [bar]	100 – 600
Pressing time (depending on clamping pressure and oil temperature)	ca. 6 s at 600 bar
Working temperature [°C]	+15 to +40
Noise emission [dB(A)]	< 70 (measuring distance 1 m)

Pump	Reference value	Value
	Voltage/frequency	SVP - Mini auto <ul style="list-style-type: none"> • Id-No. 25004523: 230 V AC, 50 - 60 Hz • Id-No. 25005600: 110 V AC, 50 - 60 Hz SVP - RM auto <ul style="list-style-type: none"> • Id-No. 25004525: 230 V AC, 50 - 60 Hz • Id-No. 25005599: 110 V AC, 50 - 60 Hz
	Power [W]	200
	Drive motor	DC-Permanent Magnet Motor
	Hydraulic liquid	Hydraulic oil: AGIP EXIDIA HG 68
	Weight [kg]	5.2
	Dimensions (LxBxH) [mm]	610 x 320 x 460
	IP protection class	IP 43
	Promotional volume [l/min]	0.06 – 0.74
	On-time of the pump ED S3	<ul style="list-style-type: none"> • for 20 °C: 100% / 60 min • for 40 °C: 40% / 60 min Operating time 24 minutes, break time 36 minutes
	Interface	USB 2.0

3.2 Polygonal jaw chuck

Reference value	Seize	Value
Clamping \varnothing D1 [mm]	TRIBOS-Mini	1 – 6
	TRIBOS-RM	3 – 12
O.D. \varnothing D2 [mm]	TRIBOS-Mini	9
	TRIBOS-RM	20
Clamping length [mm]	TRIBOS-Mini	22.5
	TRIBOS-RM	30

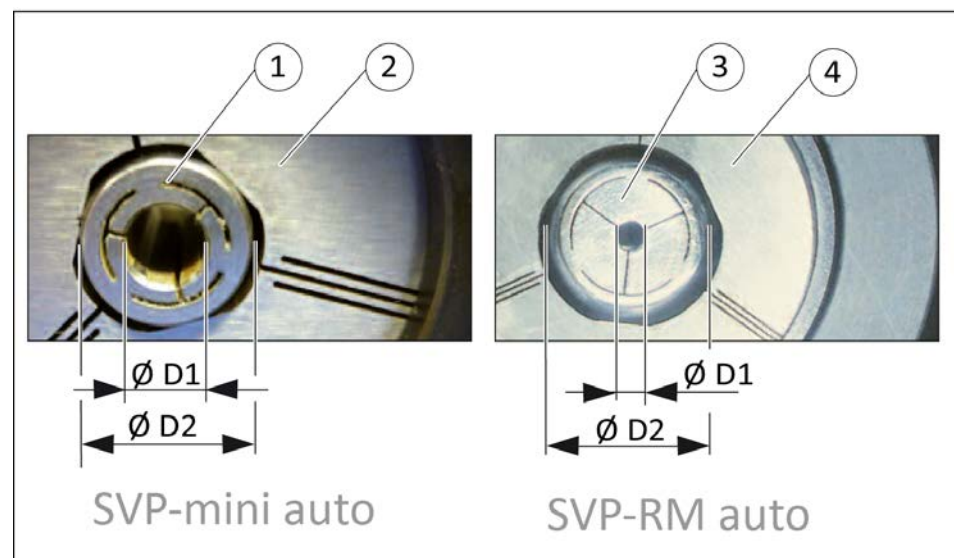

Clamping device with polygon jaw chuck

1	Polygonal jaw chuck TRIBOS-Mini
2	Intermediate sleeve SVP-Mini auto with 120° angular offset
3	Polygonal jaw chuck TRIBOS-RM
4	Intermediate sleeve SVP-RM auto with 120° angular offset

NOTE

For further information regarding TRIBOS polygonal jaw chuck, see separate assembly and operating manual.

3.3 Accessories

Battery	Reference value	Value
	Voltage [V DC]	18
	Battery capacity [Ah]	3
	Battery type	Li-Ion

Battery charger	Reference value	Value
	Voltage [V AC]	230 or 110 (depends on the ordered variant)
	Frequency [Hz]	50-60

3.4 Name plates

There is a name plate at the housing of the clamping unit with the following details:

- Manufacturer
- Id.-no.
- Product designation
- Designation of origin
- Designation of the clamping system



Name plate of the clamping device

There is a name plate on the bottom of the pump with the following details:

- Serial number
- Year of manufacture
- Technical data:
 - Pressure
 - Voltage
 - Power
 - Weight
 - IP Code

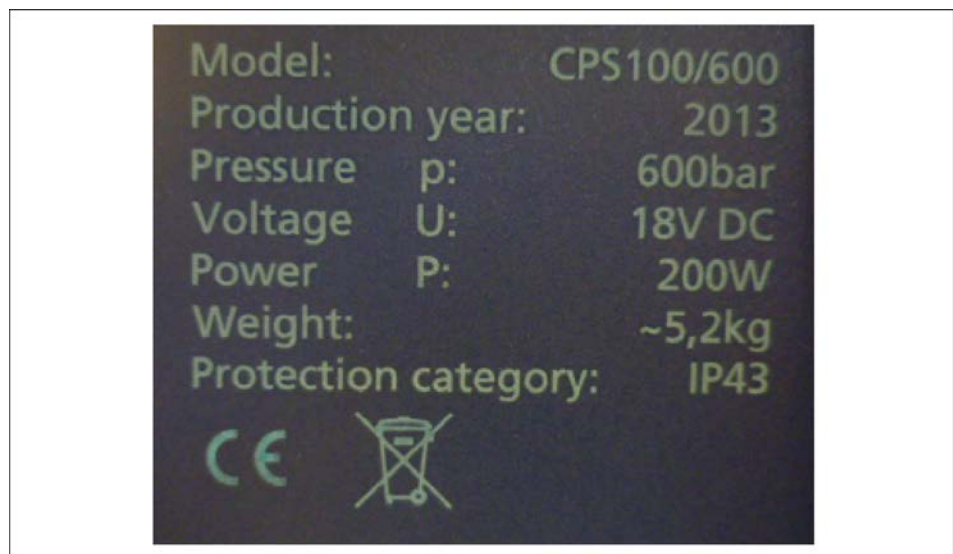

Name plate of the pump

4 Design and description

4.1 Design

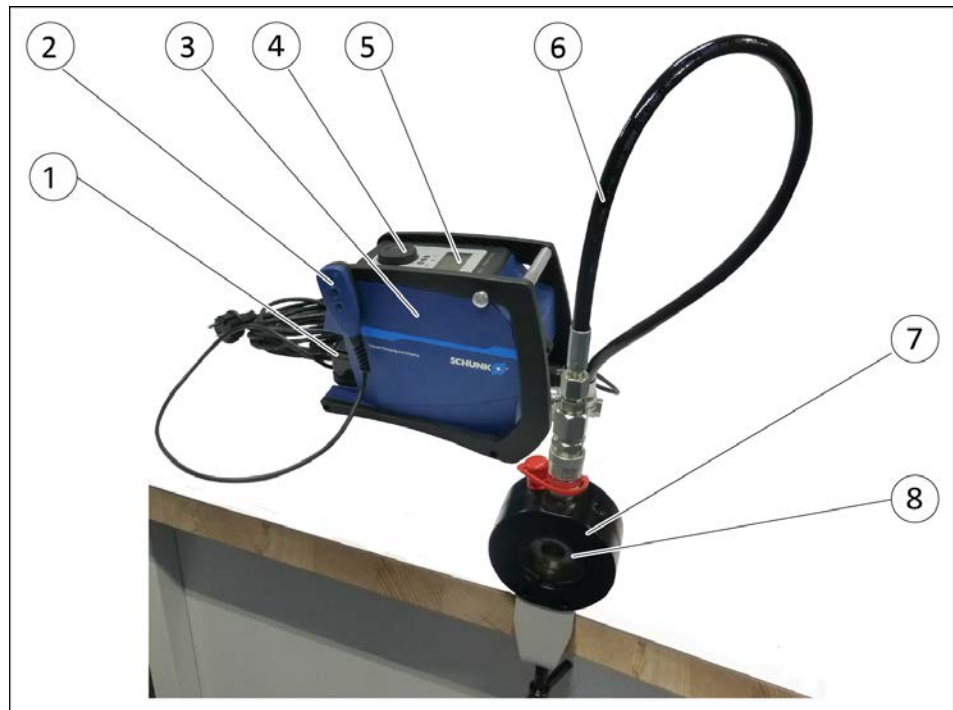

Design of the clamping device

1	Power supply unit with power plug	5	Display
2	Remote control unit	6	Hydraulic hose
3	Pump	7	Clamping unit
4	Rotary knob	8	Intermediate sleeve

4.2 Description

Functioning The polygonal jaw chuck is inserted in the intermediate sleeve (8) of the clamping unit (7). The pump (3) puts pressure on the clamping unit. Under pressure the polygon-like clamping diameter is getting round and the tool can be inserted. After the pressure relief, the clamping diameter deforms again into a polygon and the tool is clamped.

- Pump**
- The pump's safety valve is adjusted to 630 bar.
 - An electronic pressure sensor is used to monitor the pressure.
 - The pump body and all the functional components are made of tested, high-strength materials. The light and compact pump housing is made of insulated, shock-resistant, glass-fiber-reinforced polyamide.

- The pressure curve can be displayed graphically on the display.
- The pump is operated by a rotary knob. The clamping pressure can be increased and decreased with the remote control.
- The clamping cycles are recorded and evaluated on an internal memory.
- The USB interface can be used to export stored data, to update the software and to perform remote diagnostics.

Power supply unit For supplying the pump with energy, a power supply unit is included in the standard scope of delivery

Battery (optional) Optionally, the pump can be operated on battery power. Accessories such as battery and battery charger can be bought at SCHUNK ([☞ 1.4, Page 7](#)).

Clamping unit

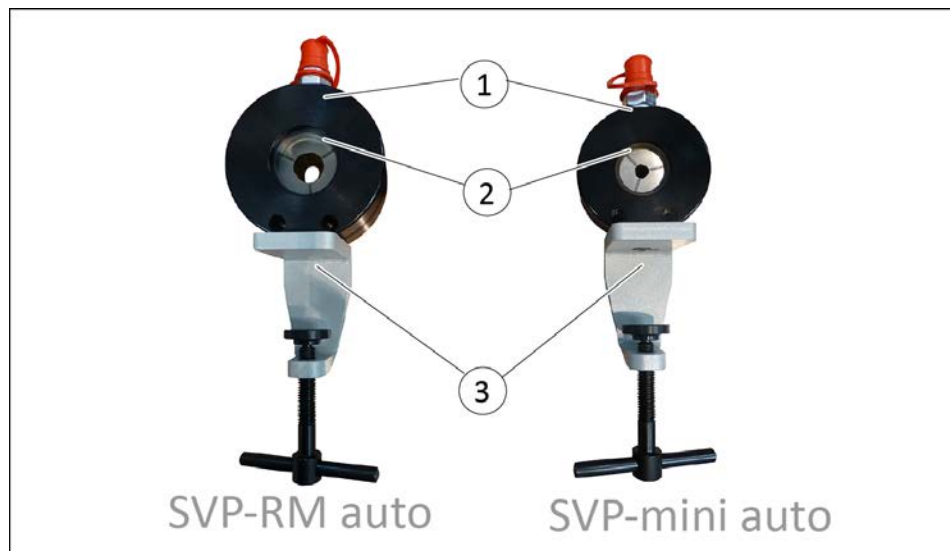

Clamping unit

1	Housing
2	Intermediate sleeve
3	Bracket (optional)

The polygonal jaw chuck is positioned in the intermediate sleeve. The SVP-Mini auto has a clamping force of up to 140,000 N and the SVP-RM of up to 345,000 N.

The clamping unit can be fastened to a workbench with a bracket. The bracket is not included in the scope of delivery and is available as accessory at SCHUNK ([☞ 1.4, Page 7](#)).

5 Assembly

5.1 Connections

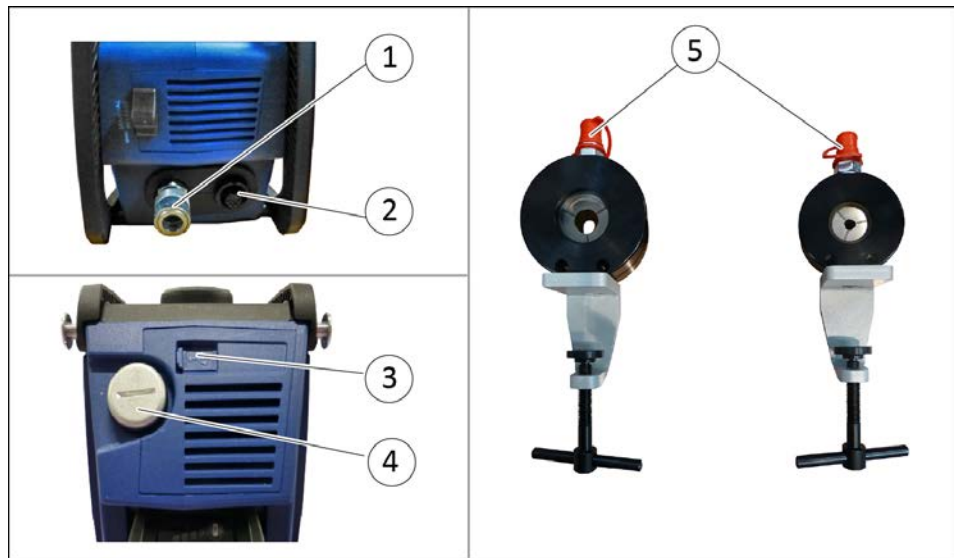

Connections

1	Connection for hydraulic hose
2	Connection for remote control
3	USB port
4	Oil filler screw
5	Connection for hydraulic hose of clamping unit

5.2 Assembling the clamping unit

There are mounting options at the clamping unit for horizontal and vertical assembly. A bracket for assembling the unit to a workbench is available as accessory at SCHUNK.

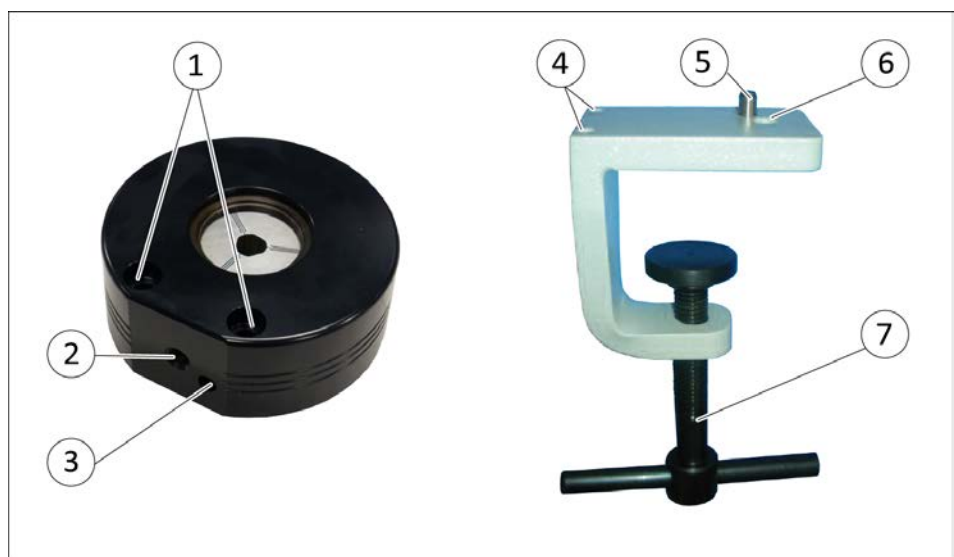

**⚠ CAUTION****Risk of injury due to falling of heavy parts.**

The clamping unit or the bracket may fall down and cause injuries.

- Before assembling the unit, ensure there is enough space for the erection.
- Wear protective equipment.

Assembling the clamping unit vertically

- 1 Position the clamping unit with the drill hole (3) on the anti-rotation device (5).
- 2 Turn the screw through the drill hole (6) into the thread (2) and tighten it.
- 3 Position the bracket on the edge of the workbench and tighten the clamping screw (7).
- 4 Remove protective cap (8).

Assembling the clamping unit horizontally

- 1 Position the bracket on the workbench and tighten the clamping screw (7).
- 2 Adjust the drill holes (1) of the clamping unit via the threaded holes (4) of the bracket.
- 3 Fasten the clamping unit with screws.
- 4 Remove protective cap (8).

5.3 Connecting the pump

NOTE

The pump is already supplied with hydraulic oil.
The pump can be operated with a battery, which is available as accessory at SCHUNK.

Transport the pump



- 1 Position loop of the carry strap (2) on the bolt for the carry strap (1) with the tip pointing upwards.
- 2 Pull carry strap down until loop of the carry strap clicks into place.
- 3 Turn the carry strap 180° to the top.
- 4 Fasten carry strap to the three other carry strap bolts.
- 5 Put carry strap around your shoulder and transport pump carefully to the operating site.
- 6 Position pump on a workbench.

Connect the pump

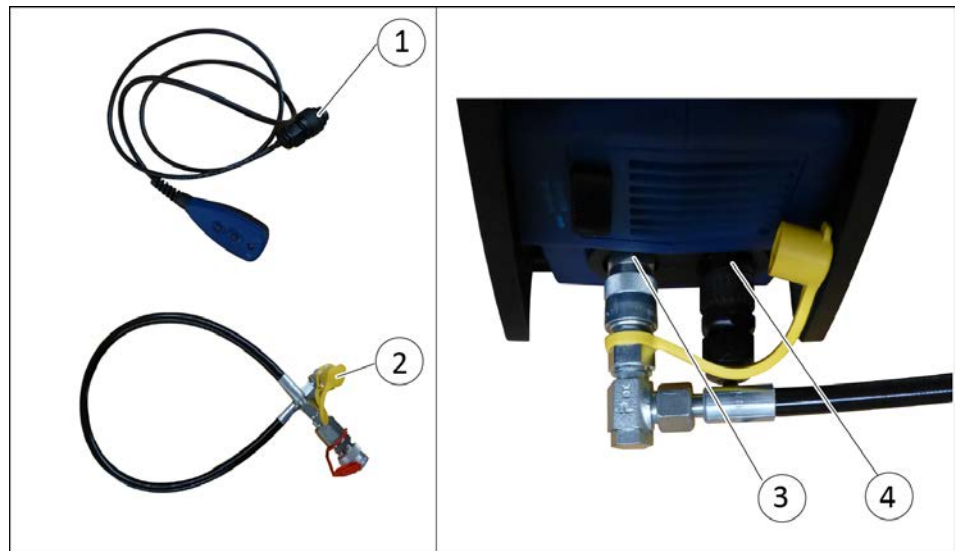

- 1 Remove protective cap (1) from the remote control cable.
- 2 Remove protective cap (2) from the hydraulic hose.
- 3 Put coupling of the hydraulic hose on the connection (3).
- 4 Connect hydraulic hose with the clamping unit.
- 5 Plug remote control cable in the bushing (4) and tighten it.

Power supply during mains operation



Inserting power supply unit

- 1 Press left and right unlocking button of the power supply unit (2) simultaneously and move power supply unit into the housing (3) until it clicks into place.
- 2 Plug power plug (1) in a properly installed socket.

Power supply during battery mode (optional)

- 1 Move charged battery into the pump (3) until it clicks into place ([↗ 6.6.2, Page 48](#))

Further notes on operating the pump: ([↗ 6.2, Page 27](#))

6 Operation

6.1 Displays and controls

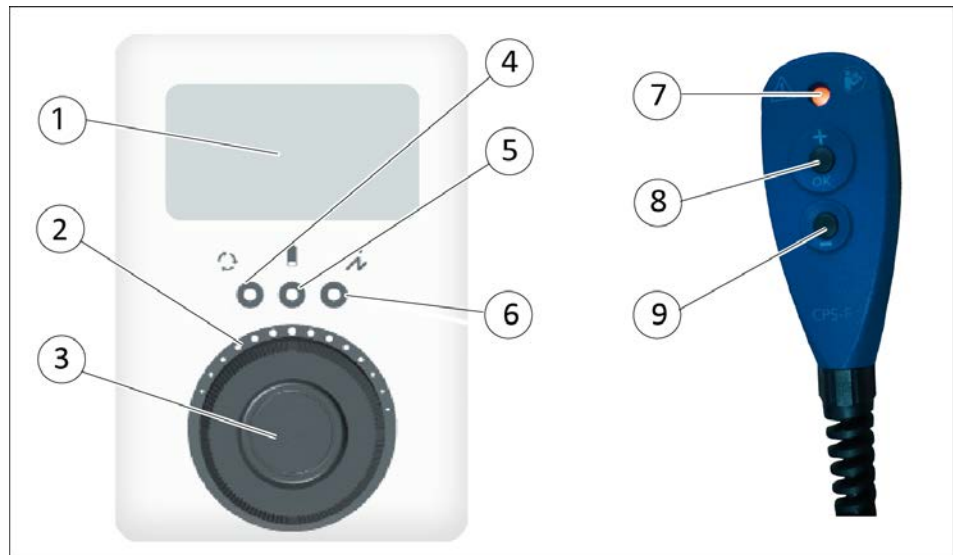

Displays and controls

1	Display	7	"Function" LED
2	Rotary knob	8	"+" button for building up pressure
3	"Enter" button	9	"-" button for reducing pressure
4	"Automatic mode" LED		
5	"Battery status" LED		
6	"Info" LED		

NOTE

At the back of the remote control there is a magnetic bracket and a fastening clip to attach it to the pump, a belt or a carry strap.

- "Automatic operation" LED lights up during an automatically performed clamping cycle.
- "Battery status" LED lights up red, if status is too low.
- "Info" LED shows different faults, see chapter [\(7, Page 49\)](#).
- "Function" LED shows different operation modes, for more information see the following table.

Operation modes of "function" LED

Color	Meaning
Orange	Lights up when switching on
Green	Lights up if clamping cycle is functioning well.
Red	Lights up if clamping cycle is faulty.
Red and green	Flashes if maintenance is due.

6.2 Operating the pump

6.2.1 Switching pump on and off

- 1 Press "enter" to turn the pump on.
⇒ The pump is ready for operation.
- 2 Press and hold "enter" for 3 seconds to turn the pump off.

NOTE

If the control program is not operated, the pump turns into sleep mode after 3 minutes. The display turns off and can be turned on again by pressing "enter".

6.2.2 Overview user interface

After turning the pump on, the tab "main page" appears on the display.

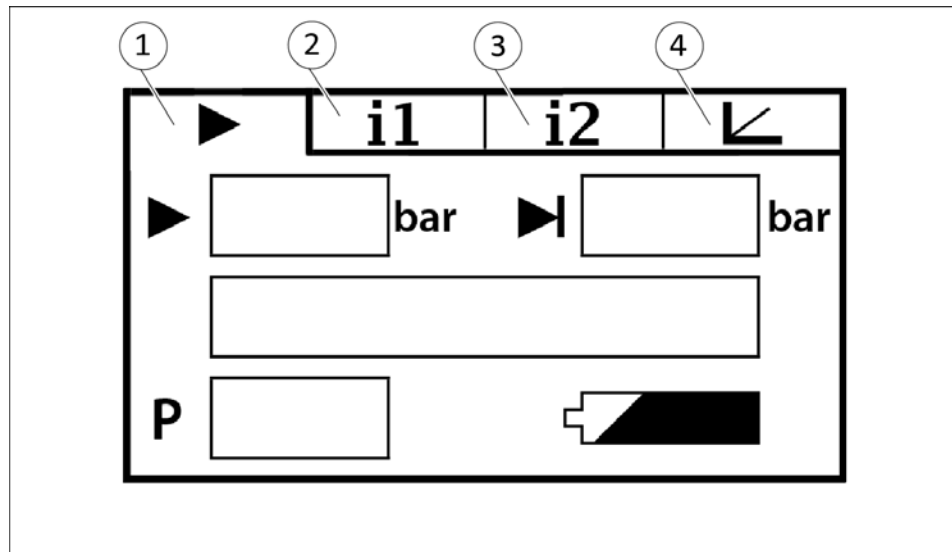

"Main page" tab

1	"Main page" tab (↖ 6.2.3, Page 29)
2	"Info 1" tab (↖ 6.2.4, Page 31)
3	"Info 2" tab (↖ 6.2.5, Page 32)
4	"Progress of work cycle" tab (↖ 6.2.6, Page 33)

Choose tabs or input fields

- 1 Press "enter" to activate the rotary knob.
- 2 Turn the rotary knob to choose the desired tab or input field.
⇒ The tab and the input field are highlighted black.
- 3 Press "enter" to confirm the selection.

6.2.3 "Main page" tab

Under the "main page" tab programmes can be selected, which are adjusted to the clamping devices "SVP or "SVP-mini auto". In these programmes parameters such as the clamping pressure set point have been set.

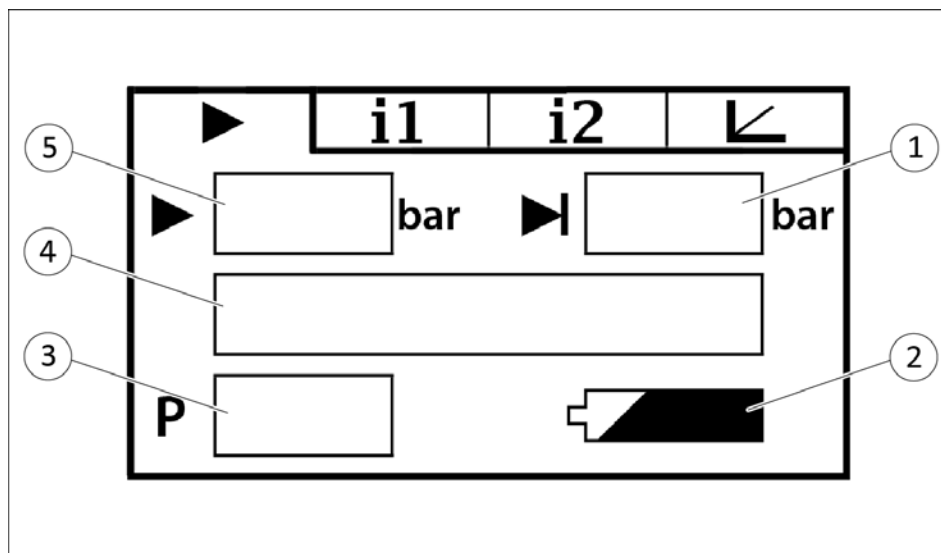

"Main page" tab

1	"Clamping pressure set point" display
2	"Battery status" display
3	"Program" selection
4	"Program designation" display
5	"Actual clamping pressure value" display

NOTE

Programmes have already been saved in the pump control ex works. It is possible to save further programmes, see section [\(👉 6.5, Page 38\)](#)

Select program



CAUTION

Material damage caused by too high clamping pressure.

If the clamping pressure is too high, the clamping unit and the polygonal jaw chuck may deform.

- Do not use program "P01: Standard". This program is only intended for SCHUNK service personnel.
- Do only use program "P02: Tribos-Mini-AD9-Stand." for SVP-Mini auto.
- Do only use program "P03: Tribos-RM-AD20-Stand." for SVP-RM auto.
- Do only use program "P04: Tribos-RM-AD20-WK19" for SVP-RM auto.

1 Select program (3) and press "enter".

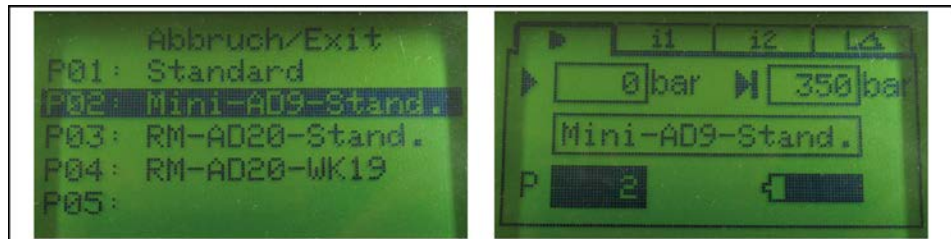

Program for SVP-Mini auto

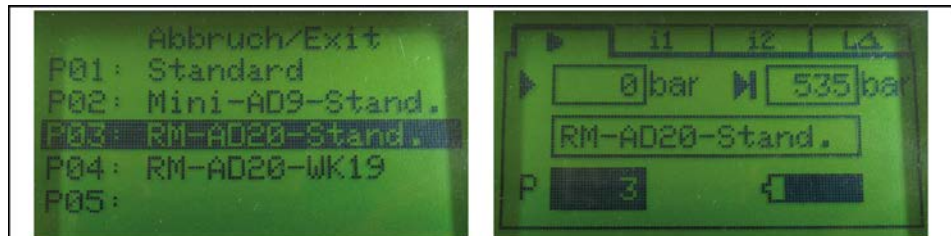

Program for SVP-RM auto

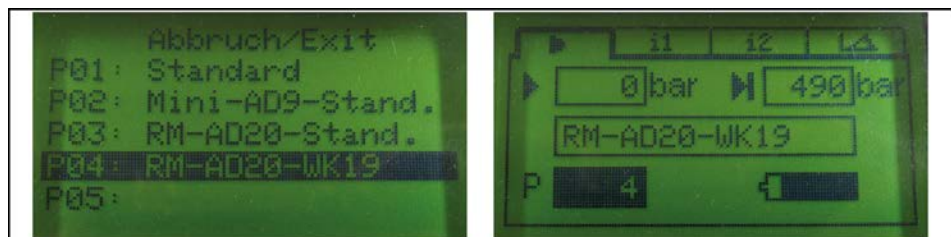

Program for SVP-RM auto

2 Select the required program and press "enter".

⇒ Program number, program designation and the saved target pressure are displayed under the "main page" tab.

NOTE

When switching the pump on again, the last selected program is highlighted black.

6.2.4 Tab "Info 1"

Unter tab "info 1" the following information is displayed:

- Pump temperature (1)
- Serial number (2)
- Beginning date of warranty (3)

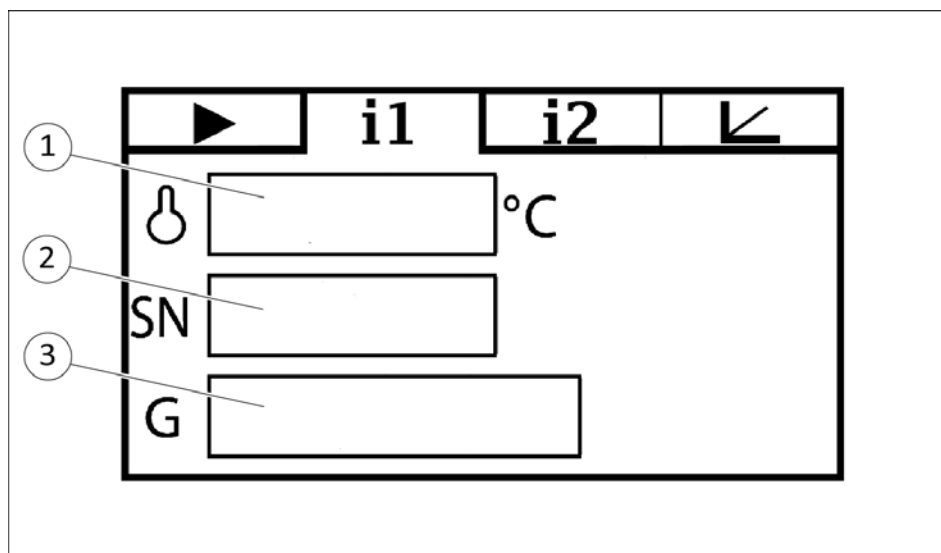

Tab "Info 1"

6.2.5 "Info 2" tab

Under "info 2" tab the following information is displayed:

- Service program (1)
- Software version
- Clamping cycles until the next maintenance (3)
- Completed clamping cycles (4)
- Motor operating hours (5)

NOTE

The service program is only designed for remote diagnostics by service personnel.

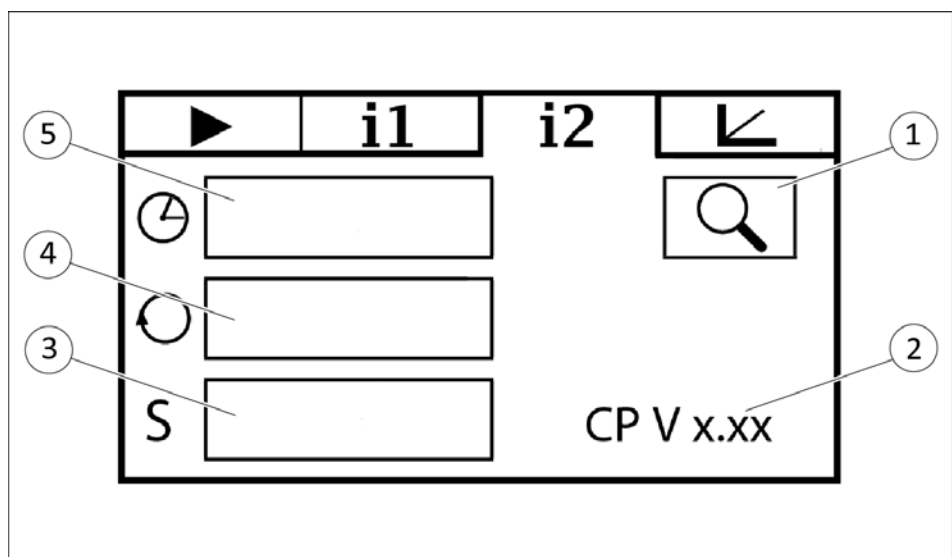

"Info 2" tab

6.2.6 "Progress of work cycle" tab

Under the "progress of work cycle" tab the following information is displayed:

- Pressure reached during the last clamping cycle (1)
- Time needed to reach this pressure level (2)
- Graphics of the pressure curve (3)

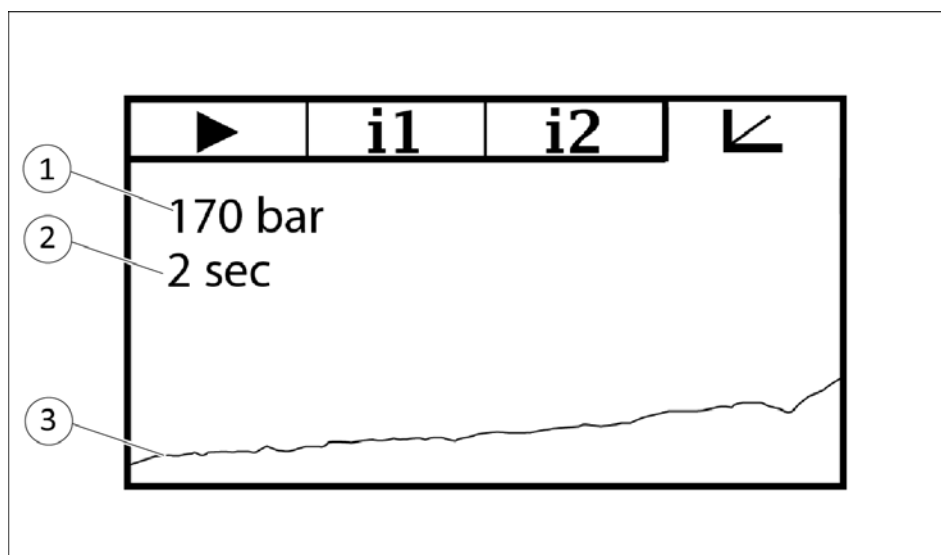

Tab "progress of work cycle"

6.3 Clamping and loosening the tool



CAUTION

Material damage due to missing or contaminated polygonal jaw chuck!

The intermediate sleeve may deform when clamping without inserted polygonal jaw chuck. Contaminated polygonal jaw chucks lead to a heavy wear of the intermediate sleeve. The clamping device is no longer functional.

- Do only insert clean polygonal jaw chuck.
- Do only build up pressure if the polygonal jaw chuck is inserted
- Push the polygonal jaw chuck into the clamping device up to the stop.

NOTE

- Please observe the operating time of the pump in continuous mode, ([↗ 3, Page 16](#))
- In case of a high operating time, the power supply unit heats up. The pump turns itself off. As soon as the power supply unit is cooled down, the pump turns on again.
- Observe operating and assembly manual of TRIBOS polygonal jaw chuck!

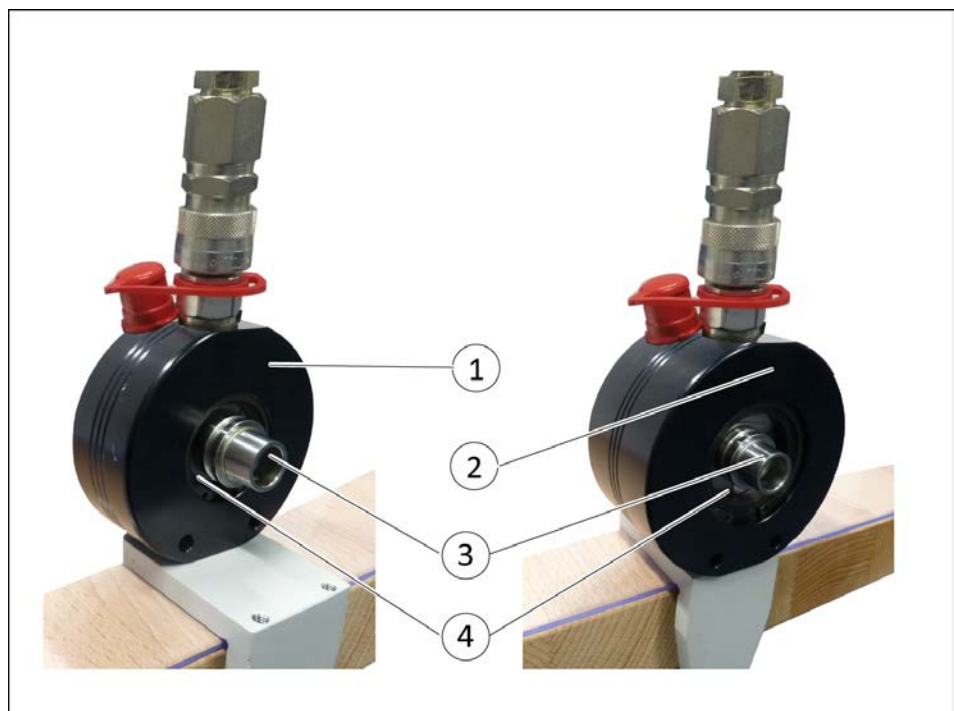

Clamping device

1	SVP-RM auto	2	SVP-Mini auto
3	Polygonal jaw chuck	4	Intermediate sleeve

CAUTION
Risk of injury due to sharp-edged tools.

- Wear protective gloves at tool change.

- 1 Push the polygonal jaw chuck (3) into the intermediate sleeve (4) up to the stop.
Note: The position of the polygonal jaw chuck is determined automatically via three segments displaced in a distance of 120°.
- 2 Select the required program under the "main page" tab ([👉 6.2.3, Page 29](#)).
- 3 Building up pressure: Press "+" on the remote control.
 - ⇒ Der Druck wird aufgebaut. Auf dem Display wird der aktuelle Istwert angezeigt.
 - ⇒ Der polygonähnliche Spanndurchmesser im Polygonspannfutter wird rund. Sobald der erforderliche Druck erreicht ist, leuchten die LED "Funktion" und die LED "Info" kurz auf.
- 4 Insert burr-free and clean tool in the polygonal jaw chuck. Observe the minimum clamping depth, see assembly and operating manual of TRIBOS polygonal jaw chuck.
OR: Remove the tool from the polygonal jaw chuck.
- 5 Reducing pressure: Press "-" on the remote control.
 - ⇒ Das Werkzeug ist im Polygonspannfutter gespannt.
- 6 Remove the polygonal jaw chuck from the intermediate sleeve

6.4 Solving problems with clamping and loosening the tool

	⚠ CAUTION
	<p>Risk of injury due to sharp-edged tools.</p> <ul style="list-style-type: none"> • Wear protective gloves at tool change.

The tool cannot be inserted into the jaw chuck:

- 1 Clean tool shank.
- 2 Remove possible elevations of the material from the tool shank, which may be caused by engraved inscriptions.

When the target pressure is reached, the tool cannot be clamped or loosened:

- 1 Cancelling the clamping procedure: Push the "-" button on the remote control.
- 2 Remove the polygonal jaw chuck.
- 3 Turn the polygonal jaw chuck by 120° and push it into the intermediate sleeve.
OR: Push the polygonal jaw chuck through the other side into the intermediate sleeve.
- 4 Repeat the clamping procedure.

The tool becomes stuck in the polygonal jaw chuck:

The tool can become stuck as a result of fine particles in the cooling lubricant

- 1 Insert a piercer through the rear opening of the polygonal jaw chuck.
- 2 Loosen the tool by pushing or gently hitting it with the piercer.

Tools with a shank in the forms E or HE:

- 1 When inserting the tool shank (1), pay attention to the position of the flattening to the pressure segments in the polygonal jaw chuck. The round shank of the tool must fit closely to the clamping surfaces of the polygonal jaw chuck.

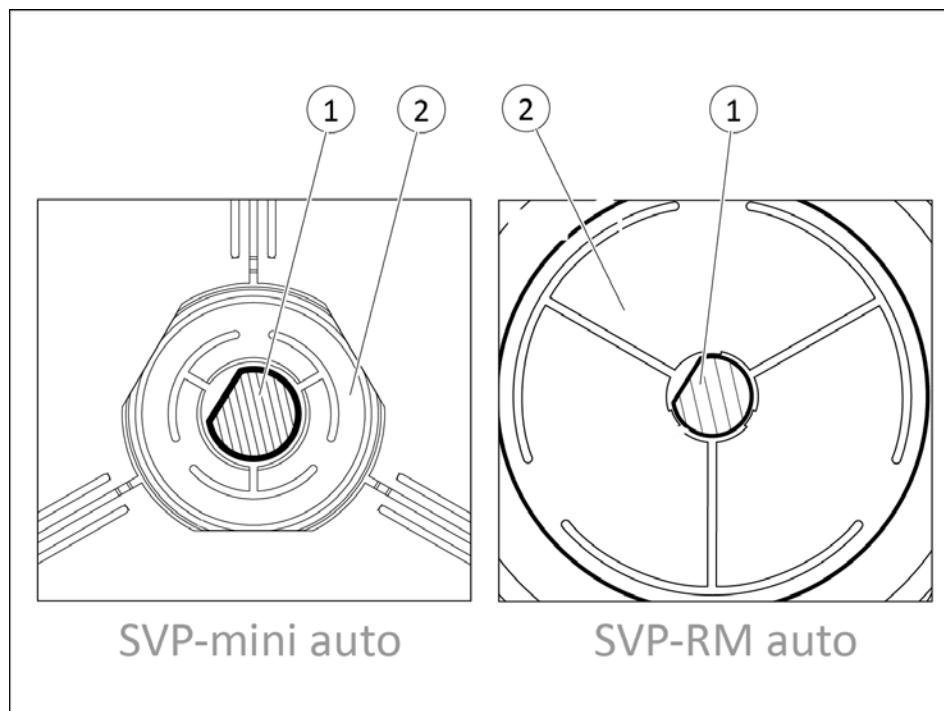

Position of the shaft

1	Tool shank Form DIN 1835 E or DIN 6535 HE
2	Polygonal jaw chuck

NOTE

For further notes regarding tools, see separate assembly and operating manual of the TRIBOS polygonal jaw chuck.

6.5 Analysis software

The analysis software displays device-specific data, saves and reads process-specific data such as clamping pressure set points and transfers them in order to operate the pump. Furthermore, firmware can be updated.

6.5.1 Installing the analysis software

System requirements

Operating system:	Windows 2000, Windows XP, Windows Vista, Windows 7
CPU:	Pentium 4, minimum 1.7 GHz
Working memory:	1 GB or more
Hard drive:	1 GB
Screen resolution:	1024 x 768 or higher, 65.535 or more colors

- 1 Download and install the analysis software as ZIP file in the download area of the SCHUNK homepage (*Service* → *downloads* → *3. Tool-holding and Workholding* → *Tribos SVP-4*).
- 2 Connect the pump to a PC via USB interface.
⇒ The pump is detected automatically.

6.5.2 Operating the analysis software

6.5.2.1 "Machine status" menu

After starting the analysis software, the following information is displayed in the "machine status" menu:

- Information on the pump e.g. serial number, warranty time, operating hours
- Graphical representation of pressure and time of the current clamping process

The graphic can be commented, printed and saved. The maximum number of lines for a comment is 10. Saved graphics can be displayed.

Note: When the clamping process is correctly performed, the apex of the curve lies within the green area. If the apex exceeds the green area, contact SCHUNK.

- Measured data of the current clamping process e.g. meter readings, pressing time, target pressure, maximum pressure

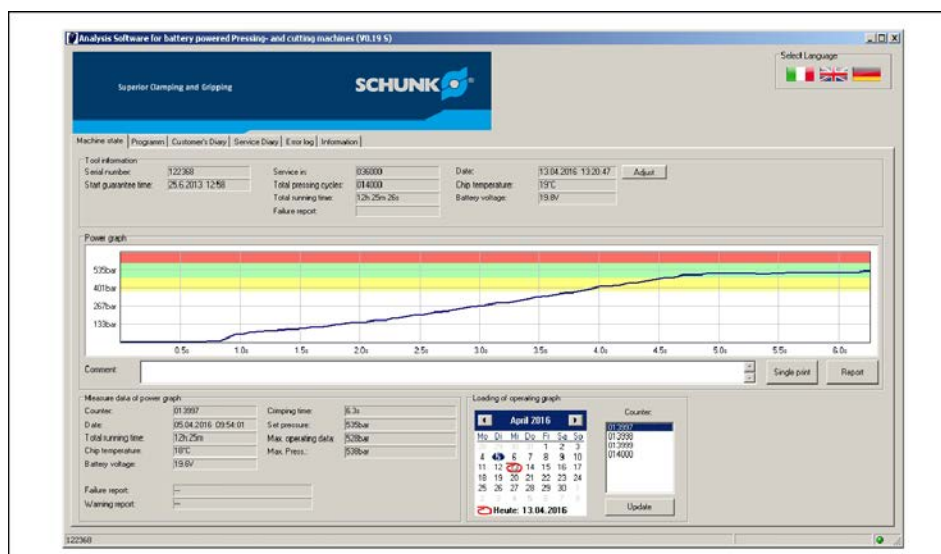

"Machine status" menu

6.5.2.2 "Programs" menu

In the "programs" menu values can be changed that are already recorded in the pump control programs. Furthermore, new programs can be added, transferred to the pump control and be saved.

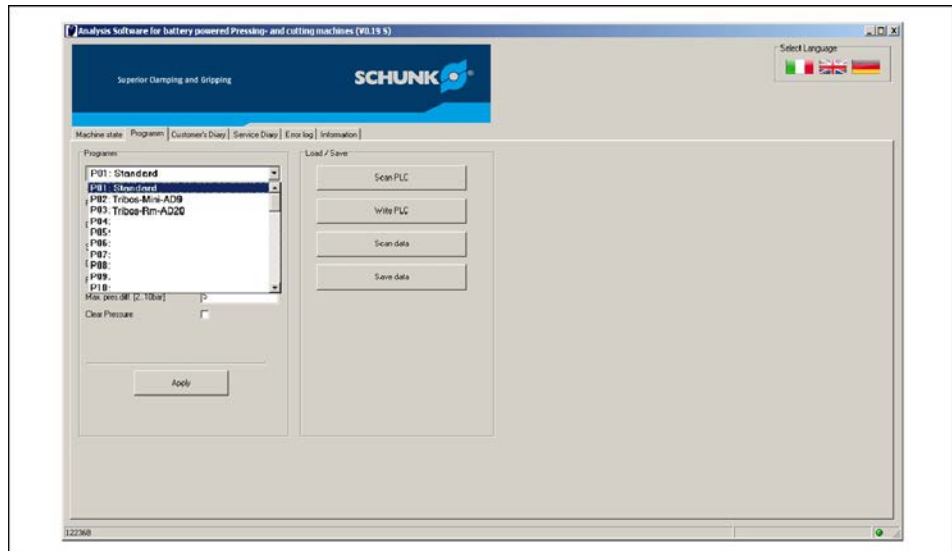

"Program" menu

Exporting values from the pump control system

- 1 Click on "load from control system".
 - ⇒ Values from the pump control are transferred to the PC and can be edited.



CAUTION

Material damage caused by too high clamping pressure.

If the clamping pressure is too high, the clamping unit and the polygonal jaw chuck may deform.

- Do not change the values of the programs P02 and P03.
- New programs should only be added by qualified personnel and by observing the SCHUNK default values.

Changing the values or adding a new program

- 1 Select the program number in the "programs" pull-down-menu.
- 2 Enter the values in the following fields: Designation, shut down pressure, holding time, runback time, max. difference in pressure.
- 3 Click on "accept".
 - ⇒ After confirming the entries are shown under the "programs" menu.

4 Click on "write to control unit".

⇒ The values have been transferred to the pump control. The program can now be selected under the "main page" tab.

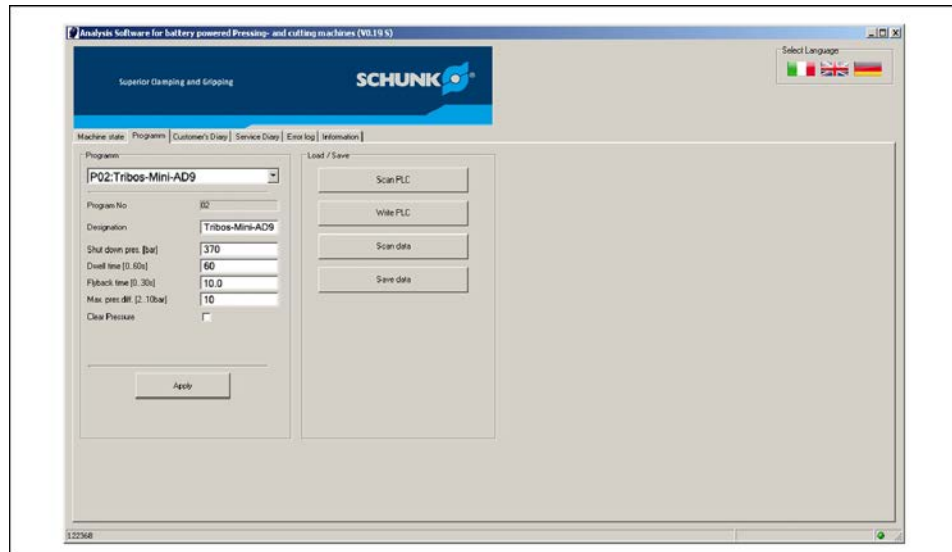

Selected program "P02"

Saving the program contents and importing them again

NOTE

SCHUNK recommends saving the data when the pump is sent to service.

- 1 Click on "save as file".
- 2 Select a memory location in the data system.
- 3 Type in file name and save as *.prg.

The data can be imported from the saved file to the pump control again:

- 1 Click on "read in from file".
- 2 Select the *.prg file in the data system.
- 3 Click on "insert in control system".

6.5.2.3 "Client diary" menu

In the "client diary" menu information regarding clamping cycles can be entered and saved.

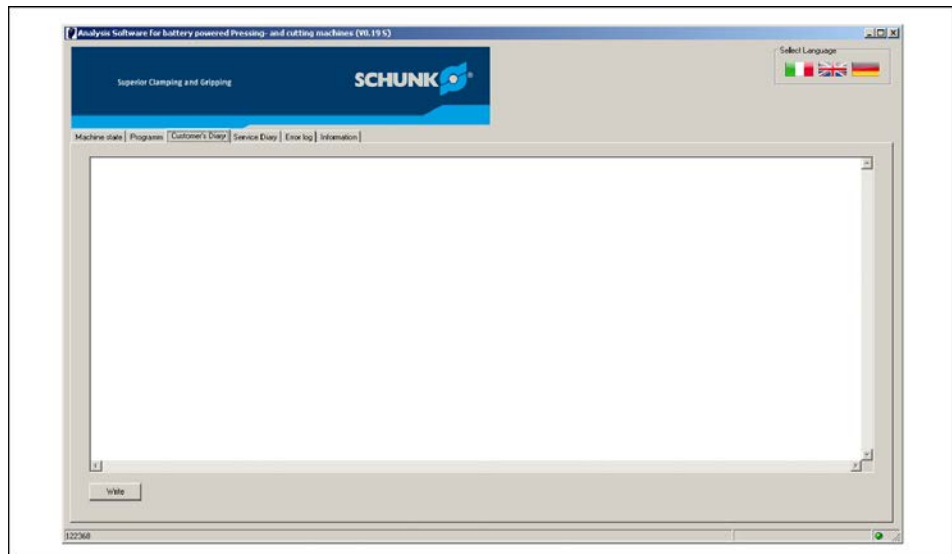

"Client diary" menu

6.5.2.4 "Service diary" menu

The "service diary" menu shows information stored by the service personnel.

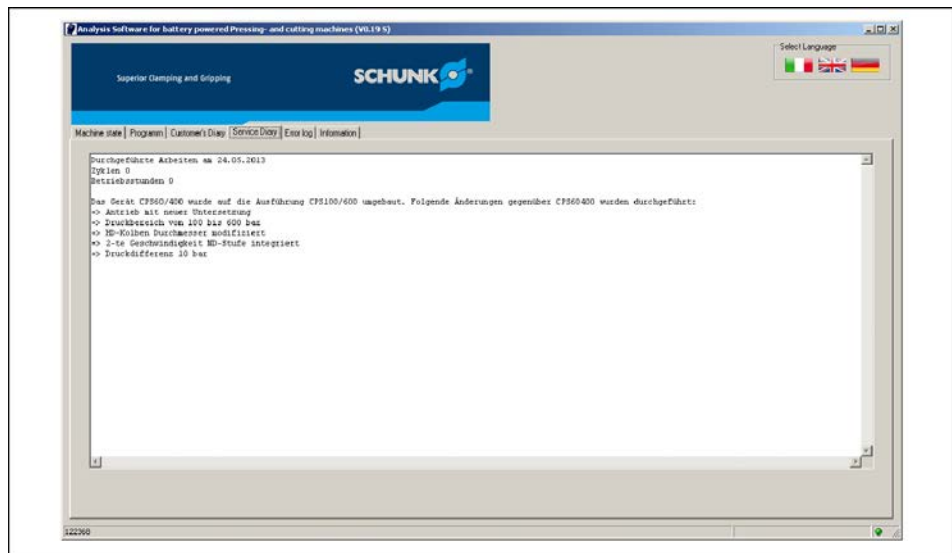

"Service diary" menu

6.5.2.5 "Fault log" menu

In the "fault log" menu fault logs are displayed. Furthermore, the firmware can be updated.

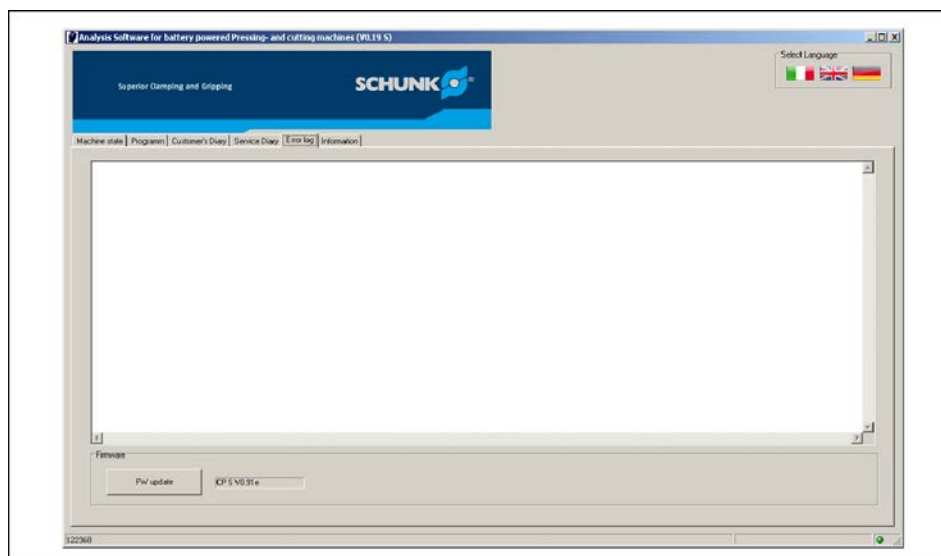

"Fault log" menu

Updating the firmware

- 1 Unplug the power supply unit.
OR: Remove the battery from the pump housing.
- 2 Press and hold "+" and "-" on the remote control simultaneously and reconnect the power plug.
OR: Insert the battery in the pump housing again.
⇒ "Battery status" LED (1) and "info" LED (2) flash alternately red and green.

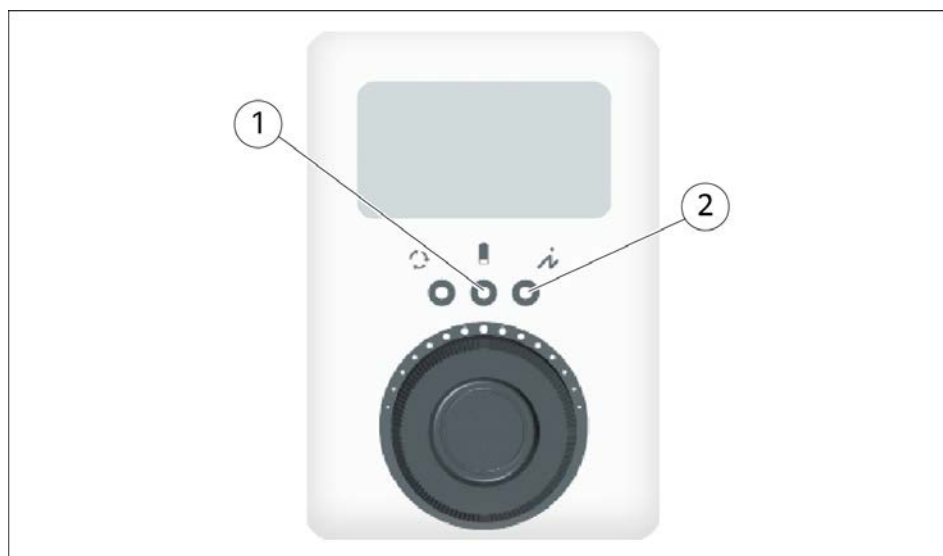

- 3 Release the "+" and "-" buttons on the remote control.
⇒ The LEDs go out.

- 4 Click on "FW Update" and select "Update-Firmwaredatei.hex."
⇒ Update starts automatically.

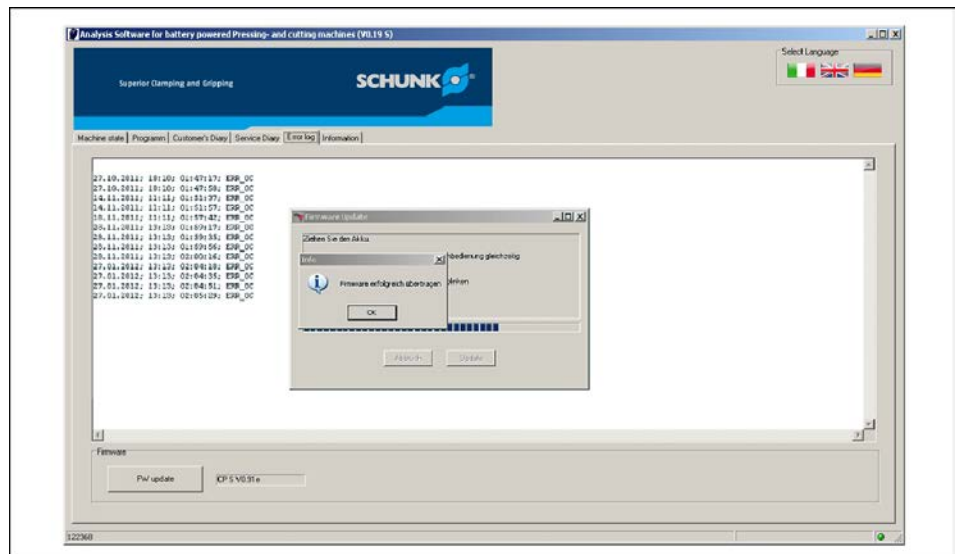

⇒ The update is completed once the message "Firmware transferred successfully" appears.

- 5 Click on "OK"
- 6 First unplug and then plug in the power plug again.
OR: Remove the battery from the pump and put it back again.

6.5.2.6 "Information" menu

In the "information" menu stored PDF documents can be displayed (e.g. operating manuals or data sheets). For displaying these documents, a PDF reader must be installed on the PC.

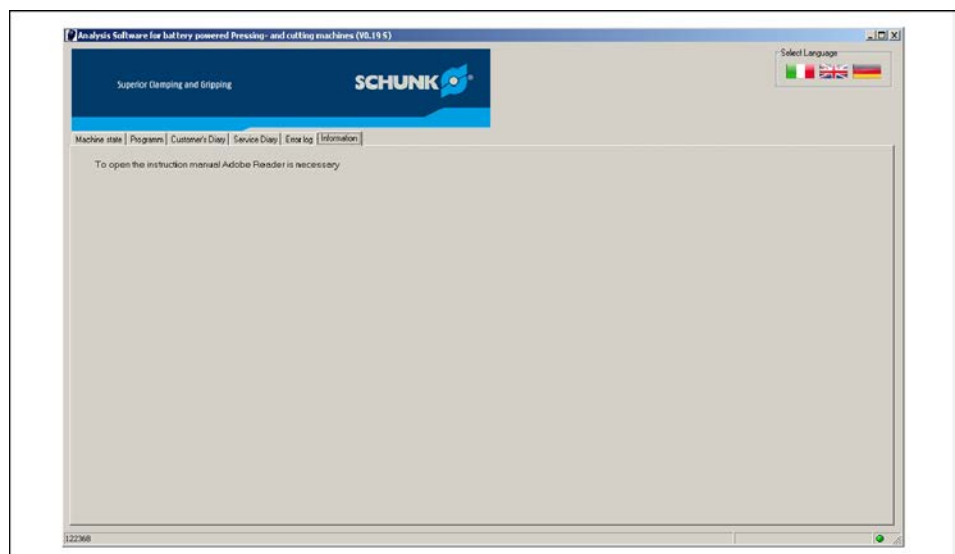

"Information" menu

6.6 Operating the pump on battery power

Optionally, the pump can be operated on battery power. Accessories such as battery and battery charger can be bought at SCHUNK ([1.4, Page 7](#)).

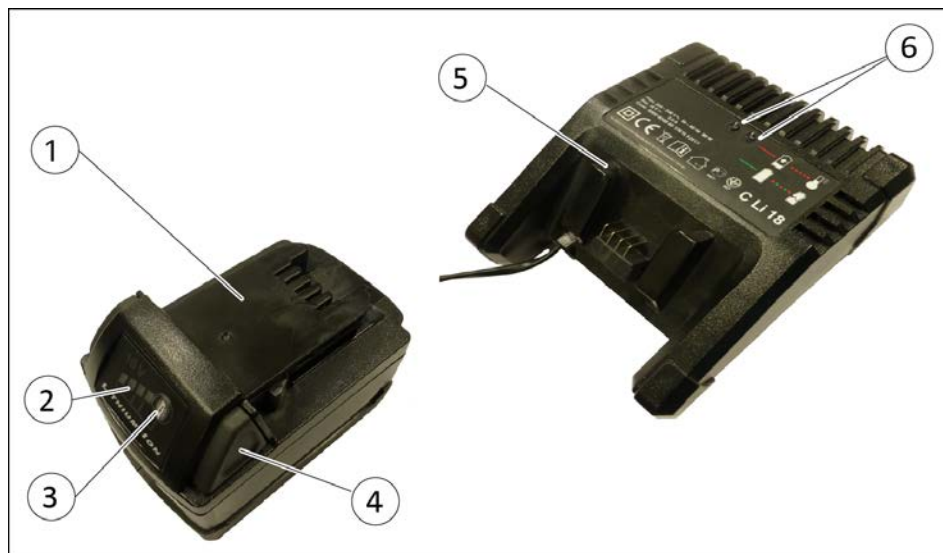

Battery and battery charger

1	Battery	5	Battery charger
2	Battery status display	6	LEDs
3	Push button		
4	Unlocking button		



! WARNING

Danger of fire due to short circuit, unsuitable batteries and chargers.

A short circuit between the battery contacts, and unsuitable batteries and chargers may result in a fire and cause serious injuries.

- Do not store batteries together with metal objects.
- Do only use batteries and chargers approved by SCHUNK.

	<p>⚠ WARNING</p>
	<p>Risk of injury due to leaking battery liquid. Touching leaking battery liquid may cause injuries.</p> <ul style="list-style-type: none"> • Prevent the battery liquid from contacting your skin. Wear safety equipment. • In case of eye contact, rinse your eyes thoroughly with water and consult a doctor. • Dispose the defective battery properly.

6.6.1 Charging the battery

The battery is supplied partially charged and must be charged before using it for the first time.

NOTE

Observe the separate operating manual of the charger manufacturer.

	<p>⚠ WARNING</p>
	<p>Danger of fire due to overheating. While charging there is the possibility that the battery heats up considerably and may cause a fire.</p> <ul style="list-style-type: none"> • Do not charge the battery in rooms where highly flammable substances and gases are located. • Remove the battery from the charger after finishing and unplug the power plug. • Do not perform unauthorized alterations to the charger.

	<p>CAUTION</p>
	<p>Material damage due to deep charging. The battery may become unusable due to deep charging.</p> <ul style="list-style-type: none"> • Remove the battery from the pump after each use. • In case of longer storage of the battery, check the status on a regular basis. Never store an empty battery longer than one month. • Recharge the battery at least every 12 months.

Charging the battery

- 1 Insert the battery (1) in the charger (5).
- 2 Plug the plug of the charger in an appropriately installed socket.
 - ⇒ The battery is charged. The LED (6) of the charger lights up red. The battery must be charged for 60 minutes.
 - ⇒ If the battery is fully charged, the LED (6) of the charger lights up green.
- 3 Remove the battery from the charger.
- 4 Unplug the plug from the socket.

Displaying the battery status.

NOTE

If the pump is de-energized, the battery status display of the battery in the pump is inaccurate.

- 1 Remove the battery from the pump.
OR: Switch off the pump at least one minute before recalling the battery status.
- 2 Push the button (3).
 - ⇒ The number of LEDs (2) lighting up on the battery indicates the battery status.

Number of LEDs lighting up	Battery status
4	78 – 100%
3	55 – 77%
2	33 – 54%
1	10 – 32%
1 flashes	10% or less

The optimum charging level is between 50% and 80%.

Note: The battery status display is only for identifying the power reserve. The actual power consumption depends on the adjusted work parameters.

6.6.2 Replacing the battery

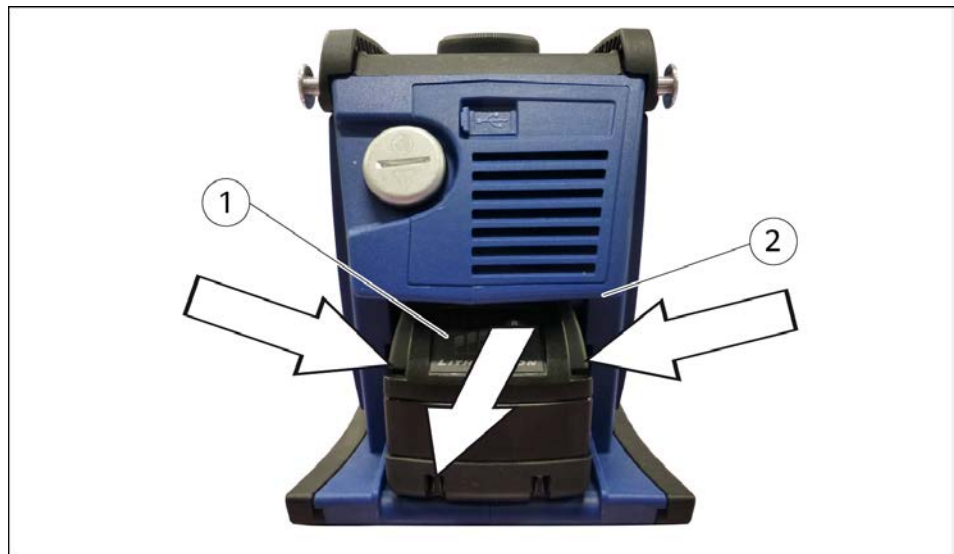

- 1 Push left and right unlocking button simultaneously and remove the battery (1) through the front side of the pump (2).
- 2 Move the recharged battery into the pump (2) until it clicks into place.

6.7 Actions after the usage

Cleaning

- Clean the intermediate sleeve in the clamping unit.
- Clean clamping diameter in the polygonal jaw chuck. Suitable tube brushes are available as accessory: ([👉 1.4, Page 7](#)).

Storage

- Store the TRIBOS clamping device in unpressurised condition.
- Slightly oil the intermediate sleeve and the housing of the clamping unit for storage.
- Cover the pump. A bag is available as accessory: ([👉 1.4, Page 7](#)).

7 Troubleshooting







Fault indications











- 1 In case of a fault, the pump turns off.
 - ⇒ The "Info" LED of the pump and the "Function" LED of the remote control light up red.
 - ⇒ On the display a corresponding error code is shown.

Correcting the fault

- 1 For correcting the fault, see table below.
- 2 Push "enter" key approx. 1 minute.
 - ⇒ Error code is deleted. The system control restarts the system.
- 3 If the error code still appears after restarting the system, contact the SCHUNK customer service.
 Service telephone: +49-7133-103-2333
 Service fax: +49-7133-103-942173

The following error codes give information on the cause of the error ([👉 6.2.3, Page 29](#)).



Note/fault	Error-Symbol	Error-Code	"Battery status" LED 	"Info" LED 
Boot loader activated			Flashing red	Flashing red
Error during initialisation of the SD card				Flashing orange
Initialisations OK				Flashing green
Target pressure is not reached after maximal time has passed		1 *		Flashing red
Operating value in red area		2		Flashing red
Battery tension low		3	Flashing red	
Operating value in yellow area				Flashing red
Operating value in green area				Flashing green
Maintenance is due				Flashing red/green
SD card error				Flashing orange
Error during initialisation of sensor temperature		4		Flashing red

Note/fault	Error-Symbol	Error-Code	"Battery status" LED 	"Info" LED 
Overload		5		Flashing red
Machine too cold (continuous control)		6		Flashing orange
Machine too hot (continuous control)		7 *		Flashing orange
Drop in pressure during compression		8		Flashing red
Fan is not working		9		Flashing red
Control of battery discharge (check battery)		10		Flashing red
Low tension of 3.3 V		11	Flashing red	
Pressure sensor error; pressure below calibration value of 0 bar		12		Flashing red
I-Fuse error. Shunt/fuse is blown or motor is running without activation		13		Flashing red

* For solutions see following table

Error code	Error	Solution
1	Oil level is too low.	<ol style="list-style-type: none"> 1 Depressurize pump. 2 Switch off pump. 3 Uncouple hydraulic hose and connection cable of the remote control. 4 Turn the pump that the oil filler screw points to the top. 5 Open oil filler screw and fill in oil up to the rim. Oil type: (🔗 3.1, Page 16) 6 Close oil filler screw.
	Pump loses oil.	<ol style="list-style-type: none"> 1 Switch off the pump immediately. 2 Send the pump to SCHUNK.
7	Air filter is contaminated.	<ol style="list-style-type: none"> 1 Send the pump to SCHUNK.

8 Maintenance

	 WARNING
	<p>Risk of injury due to improper maintenance work. Improperly performed maintenance work may cause serious injuries and considerable property damage.</p> <ul style="list-style-type: none"> • Maintenance work may only be carried out by SCHUNK.

Clamping unit The clamping unit is free of maintenance.

Pump Send the pump to SCHUNK for maintenance if the LED "info" and LED "function" on the remote control alternately flash red and green.

The first maintenance is due after 50,000 clamping cycles.
(clamping cycle = clamping + loosening)

The amount of clamping cycles until the next maintenance is showed under the tab "[\(👉 6.2.5, Page 32\)](#)".

9 Declaration of conformity

in terms of the Directive 2006/42/EC, Annex II, Part 1.A of the European Parliament and of the Council on machinery.

Manufacturer/ Distributor SCHUNK GmbH & Co. KG Spann- und Greiftechnik
Bahnhofstr. 106 – 134
D-74348 Lauffen/Neckar

We hereby declare that on the date of the declaration the following partly completed machine complied with all basic safety and health regulations found in the directive 2006/42/EC of the European Parliament and of the Council on machinery. The declaration is rendered invalid if modifications are made to the product.

Product designation: TRIBOS Polygonal Clamping System Clamping Device SVP-Mini auto/SVP-RM auto

Applied harmonized standards, especially:

EN 1005-2:2003+A1:2008 Safety of machinery- Human physical performance - Part 2: Manual handling of machinery and component parts of machinery

EN ISO 12100:2010 Safety of machinery - General principles for design - Risk assessment and risk reduction

EN 60204-1: 2006 Safety of machinery – Electrical equipment of machines, Part 1: General requirements

EN ISO 80079-36:2016 Fluid power - General rules and safety requirements for hydraulic systems and their components

The following further EU guidelines in particular:

EMC-guideline 2014/30/EU with the standards:

EN 61000-6-2 (2005) Electromagnetic compatibility (EMC) - Part 6-2: Generic standards -Immunity for industrial environments
IEC 61000-6-2: 2005

EN 61000-6-4:2007 + A1:2011 Electromagnetic compatibility (EMC) - Teil 6-4: Generic standards - Emission standard for industrial environments (IEC 61000-6-4:2006 + A1:2010)

Person authorized to compile the technical documentation:
Robert Leuthner, Address: see manufacturer's address

Signature: see original declaration

Lauffen/Neckar, July 2019

p.p. Thomas Retzbach Head of Development
Clamping Technology