

**Power Chuck**  
**ROTA NCK-S plus**  
**Assembly and Operating Manual**

## Imprint

### Copyright:

This manual is protected by copyright. The author is SCHUNK SE & Co. KG.  
All rights reserved.

### Technical changes:

We reserve the right to make alterations for the purpose of technical improvement.

**Document number:** 1151460

**Version:** 04.00 | 27/10/2025 | en

Dear Customer,

Thank you for trusting our products and our family-owned company, the leading technology supplier of robots and production machines.

Our team is always available to answer any questions on this product and other solutions. Ask us questions and challenge us. We will find a solution!

Best regards,

Your SCHUNK team

Customer Management

Tel. +49-7572-7614-1300

Fax +49-7572-7614-1039

cmm@de.schunk.com



**Please read the operating manual in full and keep it close to the product.**

## Table of Contents

|  |           |
|--|-----------|
| <b>1 General .....</b>                                   | <b>5</b>  |
| 1.1 About this manual.....                               | 5         |
| 1.1.1 Illustration of warning notices .....              | 5         |
| 1.1.2 Applicable documents .....                         | 6         |
| 1.1.3 Sizes.....   | 6         |
| 1.2 Warranty .....                                       | 6         |
| 1.3 Scope of delivery.....                               | 6         |
| <b>2 Basic safety notes.....</b>                         | <b>7</b>  |
| 2.1 Appropriate use .....                                | 7         |
| 2.2 Inappropriate use .....                              | 7         |
| 2.3 Structural changes.....                              | 8         |
| 2.4 Spare parts .....                                    | 8         |
| 2.5 Ambient conditions and operating conditions .....    | 8         |
| 2.6 Material limitations .....                           | 8         |
| 2.7 Chuck Jaws .....                                     | 9         |
| 2.8 Personnel qualifications .....                       | 9         |
| 2.9 Personal protective equipment .....                  | 10        |
| 2.10 Transport.....                                      | 10        |
| 2.11 Protection during handling and assembly .....       | 10        |
| 2.12 Protection during commissioning and operation ..... | 10        |
| 2.13 Notes on safe operation.....                        | 11        |
| 2.14 Disposal .....                                      | 11        |
| 2.15 Fundamental dangers .....                           | 11        |
| 2.16 Protection against dangerous movements .....        | 12        |
| 2.17 Notes on particular risks .....                     | 12        |
| <b>3 Technical data .....</b>                            | <b>14</b> |
| <b>4 Function and handling .....</b>                     | <b>15</b> |
| 4.1 Function of the lathe chuck.....                     | 15        |
| 4.2 Replacement or enlargement of jaws.....              | 15        |
| <b>5 Mounting .....</b>                                  | <b>16</b> |
| 5.1 Torques per screw .....                              | 16        |
| 5.2 Mounting in general .....                            | 16        |
| 5.2.1 Pre-assembly measures.....                         | 16        |
| 5.3 Mounting the lathe chuck .....                       | 17        |
| 5.4 Converting to VERO-S interface .....                 | 17        |
| 5.5 Connecting the lathe chuck .....                     | 17        |

|  |           |
|--|-----------|
| 5.6 Disassembling the lathe chuck .....    | 18        |
| 5.7 Assembling the lathe chuck.....        | 19        |
| <b>6 Maintenance .....</b>                 | <b>21</b> |
| 6.1 Lubrication .....                      | 21        |
| 6.2 Lubricating position.....              | 21        |
| 6.3 Maintenance and lubrication plan ..... | 22        |
| <b>7 Storage.....</b>                      | <b>23</b> |
| <b>8 Parts lists .....</b>                 | <b>24</b> |
| <b>9 Assembly drawing .....</b>            | <b>25</b> |
| <b>10 Manufacturer certificate.....</b>    | <b>26</b> |

# 1 General

## 1.1 About this manual

This manual contains important information for the safe, correct use of the product.

It is an integral part of the product and must be kept accessible for personnel at all times.

Personnel must have read and understood this manual before beginning any work. The observance of all safety notes in this manual is a prerequisite to ensure safe work processes.

The illustrations are intended to provide a basic understanding and may deviate from the actual version.

Besides this manual, other documents which apply are those listed under ▶ 1.1.2 [ 6 ]

### 1.1.1 Illustration of warning notices

To make risks clear, the following signal words and symbols are used for safety notes.



#### **⚠ DANGER**

Denotes a hazard with a high degree of risk that, if not avoided, will result in death or serious injury.



#### **⚠ WARNING**

Denotes a hazard with a medium degree of risk that, if not avoided, could result in death or serious injury.



#### **⚠ CAUTION**

Denotes a hazard with a low degree of risk that, if not avoided, could result in a minor or moderate injury.

#### **NOTICE**

Information about avoiding material damage.

### 1.1.2 Applicable documents

- General Terms and Conditions \*
- Catalog data sheet for the attached product \*
- Technical data sheet for optional attachments \*
- Approval drawings

Documents marked with a star (\*) can be downloaded at **schunk.com**.

### 1.1.3 Sizes

This guide applies to the following sizes in all variants

#### ROTA power chuck

- Size NCK-S plus 165
- Size NCK-S plus 210
- Size NCK-S plus 250
- Size NCK-S plus 315

## 1.2 Warranty

The warranty for standard products is 24 months from the date of delivery from the factory, or 50,000 cycles\* for manually operated clamping devices and 500,000 cycles\* for power operated clamping devices. For special clamping devices, it is 12 months from the date of delivery from the factory, assuming appropriate use in accordance with the following conditions:

- Observe the applicable documents, ▶ [1.1.2 \[6\]](#)
- Observance of the ambient conditions and operating conditions, ▶ [2.5 \[8\]](#)
- Observance of maintenance and lubrication intervals, ▶ [6.3 \[22\]](#)

Parts touching the workpiece and wearing parts are not covered by the warranty.

\* One cycle comprises one complete clamping procedure ("opening" and "closing").

## 1.3 Scope of delivery

- 1 **Power chuck** in the version ordered (without top jaws)
- 6 **T-nuts with screws or 3 combination T-nuts**
- 2 **WH-M-KDS swivel fittings**
- 1 **Jaw change key**
- 1 **Eye bolt, starting from size 210**
- 1 **Assembly and Operating Manual**

## 2 Basic safety notes

Improper handling, assembly and maintenance of this product may result in risk to persons and equipment if this operating manual is not observed.

### 2.1 Appropriate use

- The product is used for clamping metal and plastic workpieces on machine tools.
- The product may only be used within the scope of its technical data.
- The product is designed to be set up on a machine table or machine pallets.
- The product is intended for industrial and commercial use.
- Appropriate use of the product includes compliance with all instructions in this manual.
- Use suitable top jaws with a suitable interface.
- Clamping workpieces with temperatures between 0°C and 100°C.
- The outer dimensions of the workpiece must be smaller than or at most equal to the outer diameter of the clamping device.
- The workpiece must not undergo plastic deformation while under clamping force (clamping indentations are permissible).

### 2.2 Inappropriate use

The product is not being used appropriately if:

- the product is used as a press or a punch, as a toolholder, as a lathe chuck, as a drill or as a cutting tool.
- the technical data specified are exceeded during usage.
- workpieces are not properly clamped, paying particular attention to the specified clamping forces.
- the top jaws are not mounted properly.
- the product is not being operated properly.
- the product is operated in the stroke end positions.
- the guideways are overloaded due to the chuck jaws being too high or the selected clamping point being too high.
- the product has been insufficiently maintained.
- the product is used for turning applications over 100 RPM without consulting SCHUNK.
- the product is brought into contact with aggressive media, especially acids.
- the product is used in abrasive blasting processes, especially sandblasting.

## 2.3 Structural changes

### Implementation of structural changes

Modifications, changes or reworking, e.g. additional threads, holes, or safety devices, can damage the product or impair its functionality or safety.

- Structural changes should only be made with the written approval of SCHUNK.

## 2.4 Spare parts

### Use of unauthorized spare parts

Using unauthorized spare parts can endanger personnel and damage the product or cause it to malfunction.

- Only use original spare parts and spares authorized by SCHUNK.

## 2.5 Ambient conditions and operating conditions

### Required ambient conditions and operating conditions

Incorrect ambient and operating conditions can make the product unsafe, leading to the risk of serious injuries, considerable material damage and/or a significant reduction in the service life of the product

- Make sure that the product is only used within its defined application parameters.
- Ensure that the product is of a sufficient size for the application.
- Ensure that maintenance and lubricating intervals are observed.
- When machining, use only coolant emulsions with anti-rust properties.
- Depending on the operating conditions, the function must be checked after a certain period of operation.

## 2.6 Material limitations

The product is made of steel alloys, elastomers, aluminum alloys and brass. In addition, Microgleit LP 410 grease, Branotect anti-rust oil and Renolit HLT2 are incorporated into the product as auxiliary and operating materials. The safety data sheet for Microgleit LP 410 can be found at [www.schunk.com](http://www.schunk.com).

## 2.7 Chuck Jaws

### Requirements of the chuck jaws

When using chuck jaws, please observe the following rules:

- Change chuck jaws at a standstill and without a clamped workpiece.
- Do not use welded jaws.
- Design the chuck jaws to be as low as possible. The clamping point must be as close as possible to the housing. (clamping points at a greater distance cause higher surface pressures in the jaw guides and can significantly reduce the clamping force.)
- If the clamping point is at a greater distance from the housing, the operating pressure must be reduced.
- After a collision, the clamping device and the chuck jaws must be subjected to a crack detection test before being used again. Replace damaged parts with original SCHUNK spare parts.
- The chuck jaw mounting screws and if present, the T-nuts, must be replaced if there are signs of wear or damage. Only use screws of quality grade 12.9 in compliance with the specified tightening torques. For clamping devices with fine serration, the jaw mounting screws must be screwed into the holes closest to the clamping point.

## 2.8 Personnel qualifications

### Inadequate qualification of personnel

Any work on the product by inadequately qualified personnel can lead to serious injuries and considerable material damage.

- All work must be performed by appropriately qualified personnel.
- Personnel must have read and understood the complete manual before beginning any work on the product.
- Observe country-specific accident prevention regulations and the general safety notes.

The following personnel qualifications are required for the various activities on the product:

#### Qualified electrician

Qualified electricians have the professional training, knowledge, and experience to work on electrical systems, to recognize and avoid potential dangers, and know the relevant standards and regulations.

#### Specialist personnel

Specialist personnel have the specialized training, knowledge, and experience to perform the tasks entrusted to them, to recognize and avoid potential dangers, and know the relevant standards and regulations.

- Instructed person** Instructed persons have been instructed by the operator regarding the tasks entrusted to them and the potential dangers of inappropriate behavior.
- Manufacturer's service personnel** The manufacturer's service personnel have the specialized training, knowledge, and experience to perform the work entrusted to them and to recognize and avoid potential dangers.

## 2.9 Personal protective equipment

### Use of personal protective equipment

Personal protective equipment serves to protect staff in the event of a danger that may interfere with their health or safety at work.

## 2.10 Transport

### Handling during transport

Incorrect handling during transport can make the product unsafe and risks the danger of serious injuries and considerable material damage.

- During transport and handling, secure the product to prevent it from falling.
- Use the transport thread on the clamping device.

## 2.11 Protection during handling and assembly

### Incorrect handling and assembly

Incorrect handling and assembly can make the product unsafe and can risk the danger of serious injuries and considerable material damage.

- All work must only be performed by appropriately qualified personnel.
- Secure the system against accidental operation during all work.
- Use suitable assembly and transport equipment and take precautions to prevent jamming and crushing.

## 2.12 Protection during commissioning and operation

### Falling or violently ejected components

Falling and ejected components can lead to serious injury or death.

- Take suitable protective measures to secure the danger zone.

## 2.13 Notes on safe operation

### Incorrect manner of working by personnel

An incorrect manner of working can make the product unsafe and risks serious injuries and considerable material damage.

- Observe the safety notes and assembly instructions.
- Do not expose the product to any corrosive media. Products for special ambient conditions are excluded.
- Rectify malfunctions as soon as they occur.
- Observe the care and maintenance instructions.
- Observe the current safety, accident prevention, and environmental protection regulations for the application field of the product.
- Do not start the machine spindle until the force has built up in the chuck jaw and clamping is complete in the permissible operating range.
- Unclamping may only occur once the machine spindle has come to a standstill.

### IMPORTANT!

Following a longer shutdown period (more than 8 hours), always re-tension the clamping device in order to compensate for the setting properties of the clamping situation or possible pressure losses and the resulting loss of clamping force.

## 2.14 Disposal

### Handling of disposal

Incorrect handling during disposal can make the product unsafe and risks serious injuries and considerable material and environmental harm.

- Follow local regulations on dispatching product components for recycling or proper disposal.

## 2.15 Fundamental dangers

### General

- Disconnect power sources before installation, modification, maintenance, or calibration. Ensure that no residual energy remains in the system.
- Do not reach into the open mechanism or movement area of the product during operation.

## 2.16 Protection against dangerous movements

### Unexpected movements

If the system still retains residual energy, serious injuries can be caused while working on the product.

- Switch off the energy supply, ensure that no residual energy remains and secure against inadvertent reactivation.
- Never rely merely on the response of the monitoring function to avert danger. Assume that the drive movement is faulty as long as the installed monitors are not effective, since the effect depends on the control and the current operating state of the drive.
- To avoid accidents and/or material damage, human access to the movement range of the machine must be restricted.

## 2.17 Notes on particular risks



### **⚠ WARNING**

**Risk of injury in the event of workpiece loss due to component failure on the product as a result of exceeding the technical data.**

- The product is only allowed to be used within the scope of its technical data.



### **⚠ WARNING**

**Danger of crushing due to the chuck jaws moving to the workpiece during the clamping procedure when loading and unloading manually.**

- Do not reach between the workpiece and the chuck jaw during the clamping procedure.
- Implement the safety functions according to the integrator's risk assessment.



### **⚠ WARNING**

**Risk of injury in the event of workpiece loss due to failure or pressure reduction.**

- Implementing safety functions according to the integrator's risk assessment.
- Ensure stable pressure supply.
- Use pressure maintenance valves.



### ⚠ WARNING

**Risk of injury from falling parts during transport, assembly and disassembly of the product and its accessories.**

- Use suitable load handling equipment for transport.
- Do not linger in the danger zone.
- Wear protective equipment (protective shoes).



### ⚠ CAUTION

**Ergonomic risk to the musculoskeletal system when lifting and transporting the product using manual force.**

- Use load handling equipment for lifting and transporting.



### ⚠ CAUTION

**Allergic reactions or irritation due to skin or eye contact with lubricants on the product.**

- In case of foreseeable contact with lubricants on the product (e.g. when lubricating or cleaning),
- wear protective equipment (protective gloves, protective goggles).



### ⚠ CAUTION

**Danger for the operating personnel in case of insufficient clamping force due to ejection or falling of the workpiece!**

Due to settling behavior, the clamping force may decrease over time.

- Ensure that the clamping pressure is applied to the clamping device while the workpiece is being machined.
- Re-clamping of the workpiece with manual or pneumatic clamping devices.

### 3 Technical data

| Operating data                                       | ROTA NCK-S plus   |      |      |      |
|--|---|------|------|------|
|  | 165   | 210  | 250  | 315  |
| Max. actuating pressure [bar]                        | 195   | 195  | 120  | 120  |
| Max. clamping force* [kN]                            | 57  | 84   | 111  | 144  |
| Stroke per jaw [mm]                                  | 2.75  | 3.7  | 4.4  | 5.3  |
| Piston stroke [mm]                                   | 12  | 16   | 19   | 23   |
| Weight with base jaws [kg]                           | 20.1  | 31.2 | 47.6 | 72.4 |
| Oil consumption per double stroke [cm <sup>3</sup> ] | 33  | 55   | 140  | 214  |
| Operating temperature [°C]                           | 5 to 60   |      |      |      |
| Installation position                                | Any   |      |      |      |
| Pressure medium                                      | Hydraulic oil according to ISO VG 46, purity class according to ISO 4406:2021-01 [21/18/13] |      |      |      |
| Requirement for the pressure medium                  | filtered (10 µm), lubricity 30 N/mm <sup>2</sup> according to DIN 51347-1:2000-01           |      |      |      |
| Volumetric flow [l/min]                              | max. 9  |      |      |      |
| Oil loss by adhering oil removal [mg/cycle]          | max. 0.5  |      |      |      |

\* Clamping force is the arithmetic sum of the individual forces occurring at the clamping jaws at a distance 'H' at maximum actuating pressure.

## 4 Function and handling

The item numbers specified for the corresponding individual components relate to the chapter Drawings, ▶ 9 [16 25].

### 4.1 Function of the lathe chuck

The lathe chuck is actuated hydraulically via the two connections on the bottom. The resulting axial tensile and pressure forces are converted to the radial jaw clamping force by the wedge hook angle in the piston and base jaws.

The clamping and opening path of the chuck jaws is determined by the clamping piston. The serration of the base jaws can be used to mount standard jaws as well as special jaws for complex workpiece shapes. The top jaws are moved or changed in the open clamping position.

### 4.2 Replacement or enlargement of jaws

Tighten the jaw mounting screws (screw quality 12.9) to the specified torque, ▶ 5.1 [16].



#### ⚠ WARNING

**Risk of injury due to loss of workpiece if it is clamped at the end of the base jaw stroke.**

- Always clamp the workpiece at half of the base jaw stroke.

Chuck jaws for maximum clamping repeat accuracy must be turned or ground in the chuck under clamping pressure.

- When turning or grinding, ensure that the turning ring or turning pin is clamped **by the top jaws** and not by the base jaws.

**Tighten the jaw mounting screws with a torque wrench, ▶ 5.1 [16].**

## 5 Mounting

### 5.1 Torques per screw

**Tightening torques for mounting screws used to clamp the chuck on lathes or other suitable technical equipment (screw quality 10.9)**

| Screw size                   | M6 | M8 | M10 | M12 | M14 | M16 | M18 | M20 | M22 | M24 | M27  | M30  |
|------------------------------|----|----|-----|-----|-----|-----|-----|-----|-----|-----|------|------|
| Admissible torque $M_A$ (Nm) | 13 | 28 | 50  | 88  | 120 | 160 | 200 | 290 | 400 | 500 | 1050 | 1500 |

**Tightening torques for mounting screws used to attach top jaws onto the chuck (screw quality 12.9)**

| Screw size                        | M6 | M8 | M10 | M12 | M14 | M16 | M20 | M24 |
|-----------------------------------|----|----|-----|-----|-----|-----|-----|-----|
| Max. admissible torque $M_A$ (Nm) | 16 | 30 | 50  | 70  | 130 | 150 | 220 | 450 |

**Tightening torques for the protection sleeve mounting screws (screw quality 8.8)**

| Screw size                    | M3  | M4  | M5  | M6  |
|-------------------------------|-----|-----|-----|-----|
| Tightening torques $M_A$ (Nm) | 1.3 | 3.0 | 5.5 | 9.0 |

### 5.2 Mounting in general

#### 5.2.1 Pre-assembly measures

Carefully lift the product (e.g. using suitable lifting gear) from the packaging.



#### **⚠ WARNING**

##### **Risk of injury due to unexpected movements!**

If the power supply is switched on or residual energy remains in the system, components can move unexpectedly and cause serious injuries.

- Before starting any work on the product: Switch off the power supply and secure against restarting.
- Make sure, that no residual energy remains in the system.



#### **⚠ CAUTION**

##### **Danger of injury due to sharp edges and rough or slippery surfaces**

- Wear personal protective equipment, particularly protective gloves.

Check the delivery for completeness and for transport damage.

### 5.3 Mounting the lathe chuck

Mount the lathe chuck at both of the flange openings on the machine table. T-nuts can be mounted at the flange to align the lathe chuck.

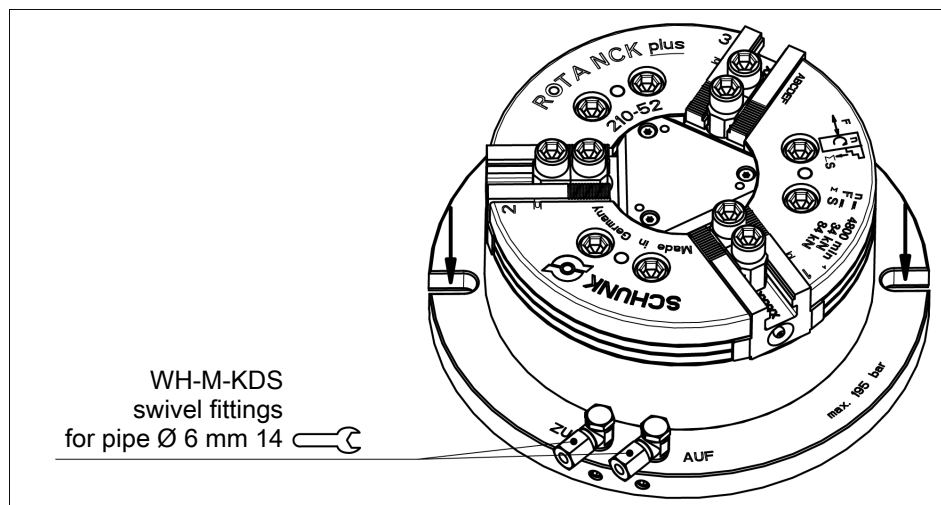

### 5.4 Converting to VERO-S interface

It is possible to fasten the lathe chuck to the machine table via a VERO-S interface with the ROTA NCK-S plus 165 and ROTA NCK-S plus 210 sizes.

In order to do this, the countersunk screw (item 41) must be removed and the retrofit kit, composed of the SPA 40 with cylindrical screw and indexing pin, must be mounted in the bore holes provided, ► 5.1 [16].

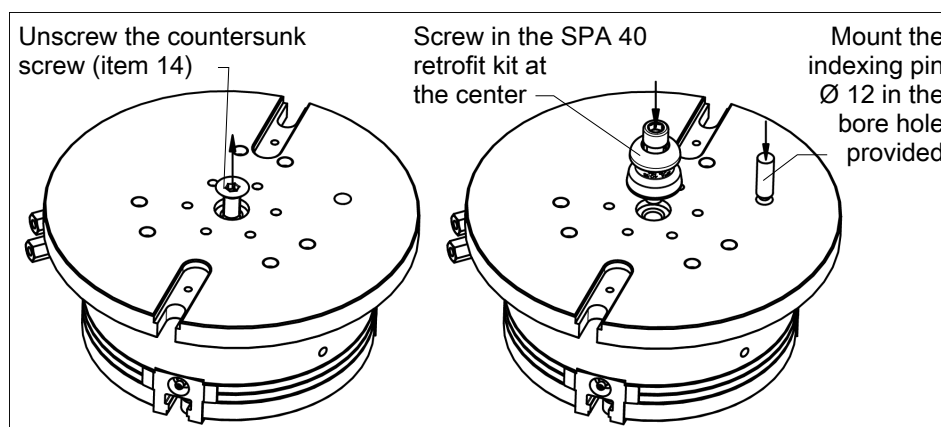

### 5.5 Connecting the lathe chuck

The lathe chuck has 2 hydraulic connections. One for OPEN and one for CLOSED. The thread for the swivel fittings is M10 x 1.

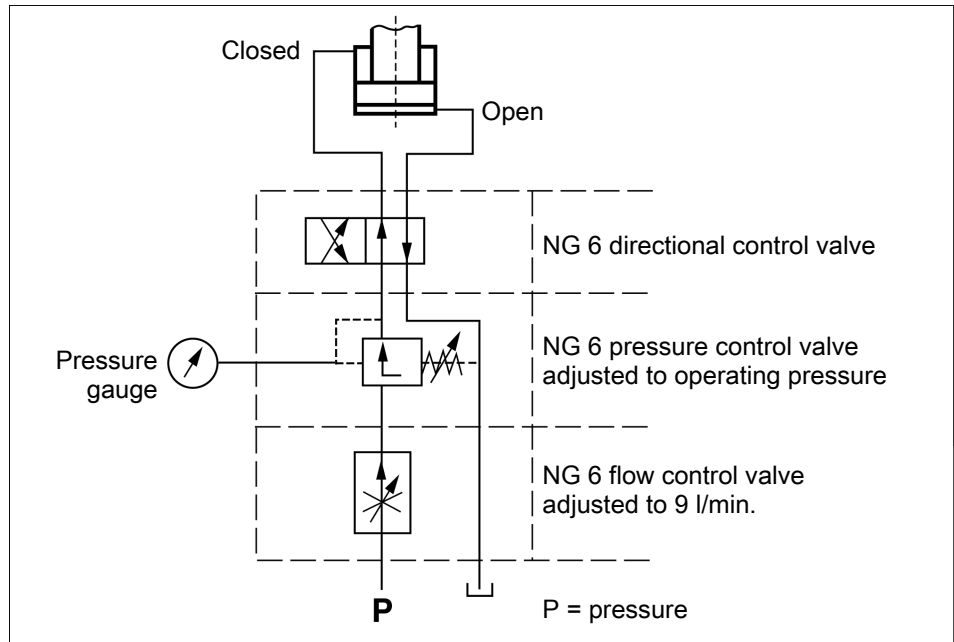

Circuit diagram

## 5.6 Disassembling the lathe chuck

**The lathe chuck can only be disassembled once it has been removed.**

- Unscrew the swivel fittings (item 45) and set-screws (item 44).
- Unscrew the screws (item 26) and remove the protection sleeve (item 14).
- Unscrew the piston cover (item 3).
- Remove the screws (item 27) and disassemble the chuck body (item 21) from the flange (item 1).
- Reverse the flange (item 1) and unscrew the screw (item 41), if present.
- Remove the screws (item 40) and the guide part (item 5). When removing the guide part, make sure that the O-rings (item 61) do not get lost.
- Unscrew the screws (item 25) and remove the retainer ring (item 29).
- Remove the first piston (item 4) and the second piston (item 23).
- Remove the wiper (item 50) from the piston (item 23) (see Fig. "Assembling the wiper").
- Push the base jaws (item 22) inwards out of the base jaw guides.
- The lathe chuck is now disassembled.

- Remove the seals (items 65, 67, 68) and the O-rings (item 61) from the piston cover (item 3), on the piston (item 4) and on the guide part (item 5).

Clean all the individual components and check for damage and wear.

**Only original SCHUNK spare parts may be used.**

## 5.7 Assembling the lathe chuck

Lubricate the parts well with LINOMAX plus special grease paste before assembling.



### ⚠ CAUTION

**Allergic reactions if lubricating grease comes into contact with the skin.**

- Wear protective gloves.

#### **Important note:**

**The wiper must be replaced while assembling the piston and may not be fitted into the piston beforehand.** This would make it impossible to mount the piston.

The wiper is slid over the guide part and placed on the support device (two-piece ring). Afterwards, the piston assembly can be attached to the guide part. The wiper is fitted into the opening on the piston during the attachment process.

- Fasten the guide part (item 5) to the flange (item 1) using the screws (item 40).
- Grease the wiper (item 50) with Renolit HLT 2 or a equivalent grease and slide it over the guide part (item 5) and place on the support device.
- Grease the seals (items 65, 67, 68) with Renolit HLT 2 or a equivalent grease and fit them to the guide part (item 5). When assembling the seals, ensure that the one-way seals (item 65, 68) are installed facing in the right direction.
- Insert the piston (item 4) into the piston (item 23) and secure using the retainer ring (item 29). Afterwards, fasten the retainer ring (item 29) with screws (item 25).
- Place the piston assembly (items 23, 4, 29) on the guide part (item 5) and slowly tap downward until the wiper (item 50) is flush in the piston (item 4).
- Remove the support device.
- Insert the jaws (item 22) into the chuck body (item 21).

- Place the chuck body (item 21) on the piston assembly (item 23, 4, 29) and insert the piston assembly into the chuck body.
- Screw the piston cover (item 3) on the guide part (item 5).
- Insert the protection sleeve (item 14) and fasten with screws (item 26).
- Fasten the chuck body (item 21) to the flange (item 1) with screws (item 27).

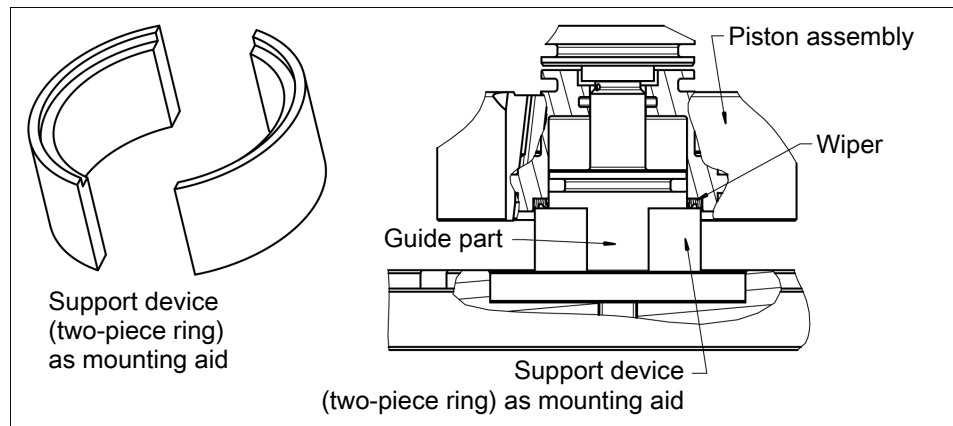

*Assembling the wiper*

## 6 Maintenance

### 6.1 Lubrication



#### ⚠ WARNING

##### **Risk of injury through contact with lubricants!**

Skin or eye contact with lubricants can cause irritation and allergic reactions.

- Avoid skin or eye contact with lubricants.
- Wear safety goggles and protective gloves.

To maintain the safe functioning and high quality of the chuck, it must be lubricated regularly at all lubrication points. For optimum grease distribution, the chuck must be lubricated in the lubricating position (► 6.2 [21]).

Depending on the operating conditions, the function and clamping force must be checked after a certain period of operation (► 6.3 [22]). Only perform the clamping force test with a calibrated clamping force tester (SCHUNK IFT). If the chuck is used over several clamping cycles in the short stroke range (< 50% clamping stroke), it is recommended to perform an empty stroke regularly to maintain the clamping force at a consistently high level.

**Lubricate the chuck evenly in order to avoid large imbalances.**

### 6.2 Lubricating position

The following procedure should be followed to ensure optimum distribution of the lubricant:

- Open the chuck and move it to the outer end position.
- Lubricate the chuck at the 3 grease nipples (item 13) with LINOMAX plus.
- Perform several empty strokes over the entire travel range of the chuck.

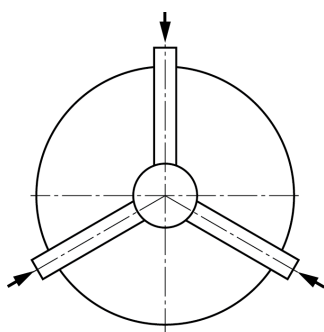

Fig. 1: Lubricating points

### 6.3 Maintenance and lubrication plan

The specified intervals are guide values and must be adjusted by the operator depending on the ambient and operating conditions and the frequency of use of the clamping device used. To determine a suitable lubrication interval for the respective application, regular clamping force tests must be carried out. If only 80% of the maximum clamping force is reached, the clamping device must be lubricated. In accordance with VDI 3106, it must be ensured that sufficient clamping force is available for the application.

| Maintenance task                   | Interval                              |
|------------------------------------|---------------------------------------|
| Lubricate                          | Every 24 operating hours              |
| Check clamping force               | To be determined by the operator      |
| Complete cleaning /<br>disassembly | Annually / after 2500 operating hours |

## 7 Storage

When storing the product for a longer period of time, observe the following points:

- Clean the product and lubricate it lightly.
- Store the product in a suitable transport container.
- Only store the product in dry rooms.
- Protect the product from major temperature fluctuations.

**NOTE:** Before recommissioning, clean the product and all attachments, check for damage, functionality and leaks.

## 8 Parts lists

When ordering spare parts, it is essential to specify the type, size and, above all, the serial number of the chuck. **Seals, sealing elements, screw connections, springs, bearings, screws and wiper strips as well as parts that come into contact with the workpiece are not covered by the warranty.**

| Item | Designation        | Quantity | Note                       |
|------|--------------------|----------|----------------------------|
| 1    | Flange             | 1        |                            |
| 3    | Piston cover       | 1        |                            |
| 4    | Piston             | 1        |                            |
| 5    | Guide part         | 1        |                            |
| 13   | Lubrication nipple | 3        |                            |
| 14   | Protection sleeve  | 1        |                            |
| 21   | Chuck body         | 1        |                            |
| 22   | Base jaws          | 3        |                            |
| 23   | Piston             | 1        |                            |
| 25   | Screw              | 6        |                            |
| 26   | Screw              | 3        |                            |
| 27   | Screw              | 6        |                            |
| 28   | T-nut              | 3        |                            |
| 29   | Retainer ring      | 1        |                            |
| 40   | Screw              | 6        |                            |
| 41   | Screw              | 1        | 165 / 210                  |
| 42   | Cylindrical pin    | 1        |                            |
| 44   | Seal plug          | 2        |                            |
| 45   | Swivel fitting     | 2        |                            |
| 50   | Wiper              | 1        | <b>X</b>                   |
| 61   | 0-ring             | 1        | 165 / <b>X</b>             |
|      | 0-ring             | 2        | 210 / 250 / 315 / <b>X</b> |
| 62   | 0-ring             | 1        | 165 / <b>X</b>             |
| 65   | Seal               | 2        | <b>X</b>                   |
| 67   | Seal               | 1        | <b>X</b>                   |
| 68   | Seal               | 1        | <b>X</b>                   |
| 80   | Eye bolt           | 1        | 210 / 250 / 315            |

### Parts list key

|     |              |     |              |
|-----|--------------|-----|--------------|
| 165 | for size 165 | 210 | for size 210 |
| 250 | for size 250 | 315 | for size 315 |

Seals are wearing parts (**X**) and are recommended to be replaced during maintenance.

### 9 Assembly drawing

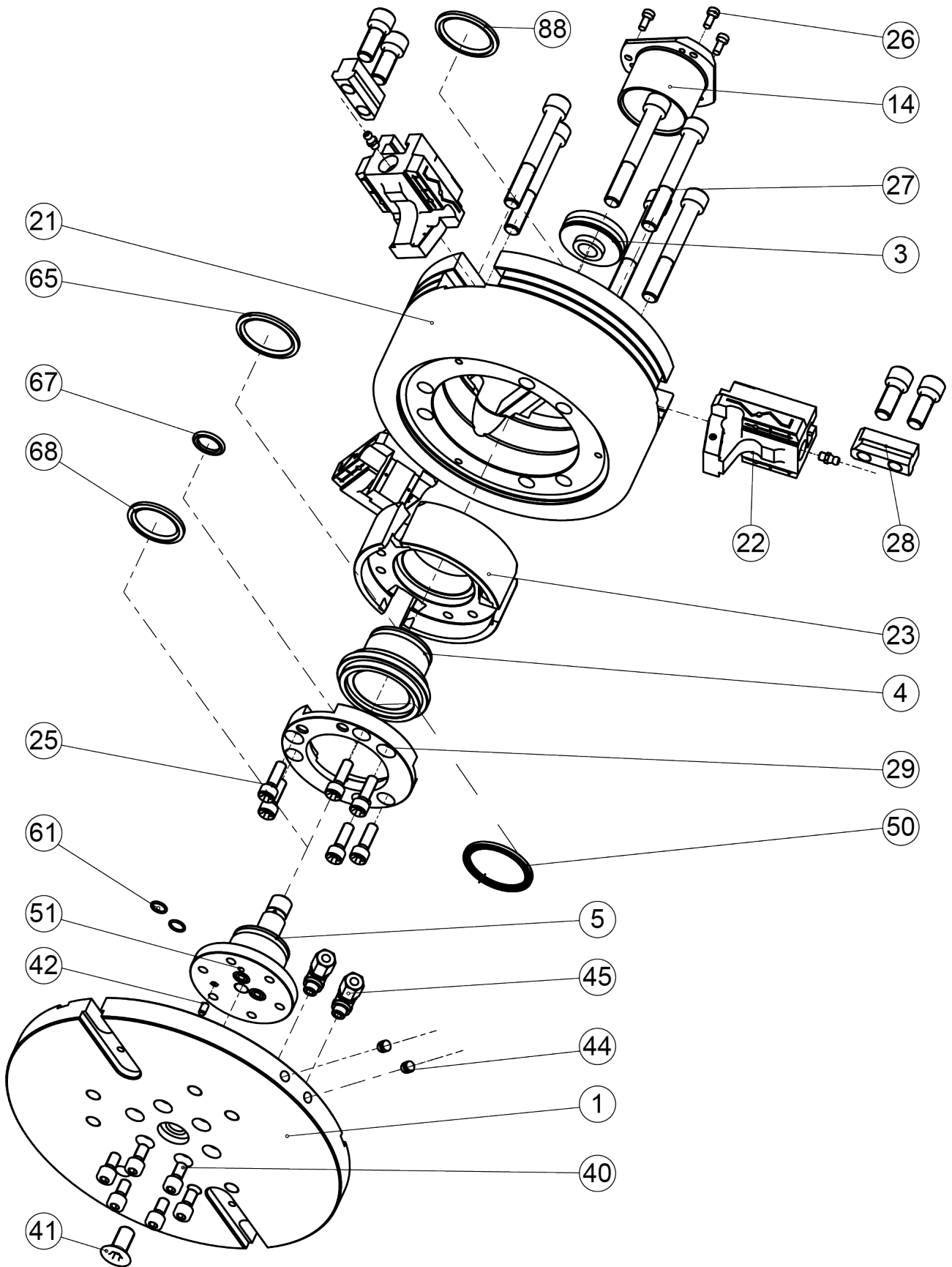

## 10 Manufacturer certificate

|                             |   |
|-----------------------------|---|
| Manufacturer / Distributor: | H.-D. SCHUNK GmbH & Co. Spanntechnik KG<br>Lothringer Str. 23<br>D-88512 Mengen |
| Product:                    | Lathe chuck   |
| Designation:                | ROTA  |
| Type designation:           | NCK-S, TPS, TBS   |

**Heinz-Dieter SCHUNK GmbH & Co. Spanntechnik KG** certifies that the above-mentioned products, when used as intended and in compliance with the operating manual and the warnings on the product, are safe according to the national regulations and:

- a **risk assessment** has been carried out in accordance with ISO 12100:2010.
- an **operating manual** for the assembly instructions has been created in accordance with the contents of the Machinery Directive 2006/42/EC Annex I No. 1.7.4.2. and the contents of the provisions of Annex VI of the Machinery Directive 2006/42/EC.
- the relevant basic and proven safety principles of the Annexes of **ISO 13849-2:2012**, taking into account the requirements of the documentation have been observed for the component. The parameters, limitations, ambient conditions, characteristic values, etc. for proper operation are defined in the operating manual.
- an  $MTTF_D$  value of 150 years can be estimated for mechanical components using the informative procedure in Table C.1 of ISO 13849-1:2015.
- **fault exclusion** against the fault "Unexpected release without pending release signal".
- the **fault exclusion** against the fault "Breakage during operation" in compliance with the parameters, limitations, ambient conditions, characteristic values and maintenance intervals, etc., specified in the operating manual.
- that internal bore diameters in the **pipe or control lines** are at least 2 mm for pneumatic clamping systems and at least 3 mm for hydraulic clamping systems

### Harmonized Standards applied:

- **ISO 12100:2010** Safety of machinery – General principles for design – Risk assessment and risk reduction
- **EN 1550:1997+A1:2008** Machine-tools safety – Safety requirements for the design and construction of lathe chucks for the workpiece mount

### Other related technical Standards and specifications:

- **ISO 702-1:2010-04** Machine tools – Connecting dimensions of spindle noses and lathe chucks – Part 1: front short-taper mount with screws
- **ISO 702-4:2010-04** Machine tools – Connecting dimensions of spindle noses and lathe chucks – Part 4: cylindrical mount
- **VDI 3106:2004-04** Determination of permissible RPM of lathe chucks (jaw chucks)

Mengen, 25th of April 2023

*Signature: see original declaration*

*Signature: see original declaration*

p.p. Philipp Schröder  
Head of Development standard products

p.p. Alexander Koch  
Head of Engineering Design special products





H.-D. SCHUNK GmbH & Co.  
Spanntechnik KG

Lothringer Str. 23  
D-88512 Mengen  
Tel. +49-7572-7614-0  
info@de.schunk.com  
schunk.com

Folgen Sie uns | *Follow us*



Wir drucken nachhaltig | *We print sustainable*